

# Nearity

# Microphone Solution

## User Manual

---



Model: AW-A40

V1.0

# Content

---

<b>1. Product Introduction</b>	01
1.1 A40 Introduction	01
1.2 AMX100 Introduction	04
1.3 ACT10 Introduction	06
1.4 ASP110 Passive Speaker Introduction	08
<b>2. A40 System Deployment Instructions</b>	09
2.1 Installation precautions	09
2.2 System connection	10
2.3 AMX100 Installation position/mode	11
2.4 Installation of A40 Unit	12
2.5 Deployment of ASP110	14
2.6 ACT10 Installation	16
2.7 3rd A/V system integration	16
<b>3. Operation on Software-Nearsync Configuration</b>	17
3.1 Download and Installation of Nearsync	17
3.2 Software Configuration	18
<b>4. FAQ</b>	25
<b>5. Caution</b>	25

# 1. Product Introduction

## ● 1.1 A40 Introduction

NEARITY A40 is an integrated ceiling microphone solution for video conferencing and in-room audio. With advanced audio technologies such as beamforming, AI noise suppression, intelligent mixing, etc., A40 ensures clarity during meetings and promotes efficient interactions. The ultimate daisy-chain technology makes the A40 an incredible productivity tool for meeting spaces of different sizes and purposes.

### 1.1.1 Features

#### - 24-element microphone array and daisy chain, ensure clarity in area sound pickup

With a built-in 24-element microphone array and daisy chain expansion up to 8 units, the NEARITY A40 can pick up sound clearly within the effective range from small to large rooms.

#### - Adaptive sidelobes, easy to capture voices in selected area

The 8 sidelobes can be customized according to different room layouts and seating arrangements to block noises out and capture effective sounds in fixed directions.

#### - Eliminate office clutter

Integrated design allows you to eliminate traditional conference equipment, leaving more room to share and work.

#### - Deep-learning AI trained to distinguish human voice from other noise

With onboard high-performance digital signal processor, Nearity A40 applies deep-learning AI capabilities, including advanced audio technologies such as audio mixing routing, echo cancellation, noise reduction, and automatic gain control, ensuring clear speech in a wide area.

### 1.1.2 A40 Physical Structure

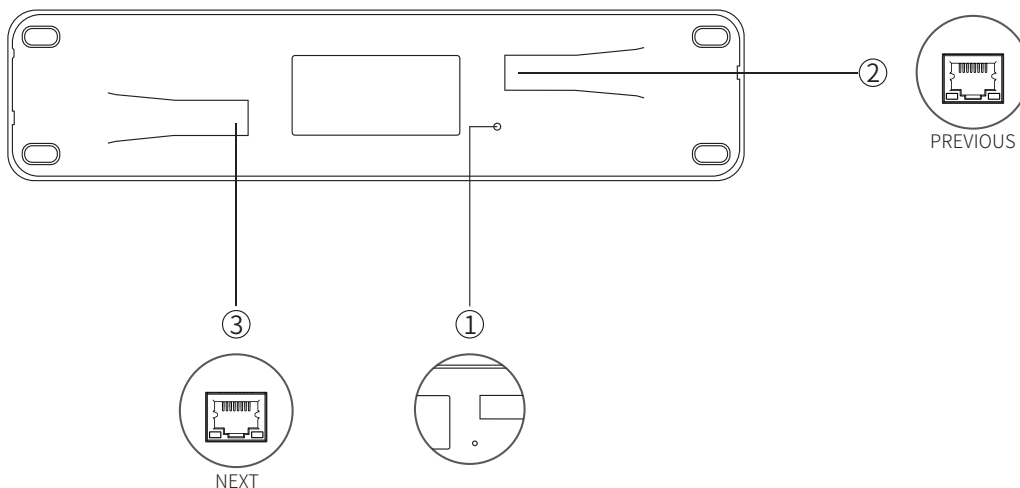

①Reset button--Factory Reset (press button for longer than 3 seconds)

②PREVIOUS--RJ45(Input)

③NEXT--RJ45(Output)

### 1.1.3 A40 Packing List

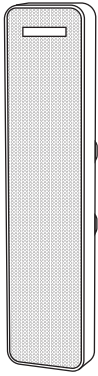

A40 \*1

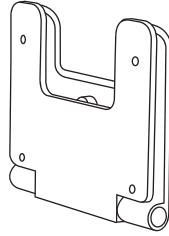

Stents\*1

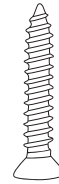

Wood tooth  
screw\*4

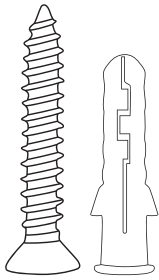

Tapping screw+  
Expansion screws\*10



Eyebolts\*2

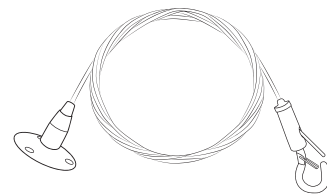

Stainless steel  
rope components\*2

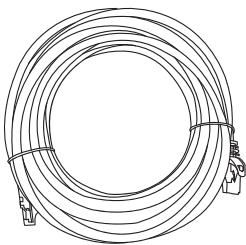

Ethernet cable\*1

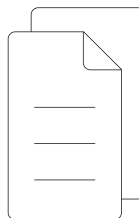

User manual\*1



Bracket screw\*4

## 1.1.4 Specification

	Technical Specifications
Microphone Features	24 MEMS microphone array
	Effective pickup range: 8m x 8m(26.2ft x 26.2ft)
	Sensitivity: -38dBV/Pa 94dB SPL@1kHz
	SNR: 63dBV/Pa 94dB SPL@1kHz,A-weighted
Audio Characteristics	8 deep sidelobes beamforming
	AI noise suppression
	Full-duplex
	Automatic Gain Control(AGC)
	Smart reverbration
	Adaptive pickup beams
	Intelligent audio mixing
Daisy-chain	POE via UTP cable(CAT6)
	Maximum daisy-chain 8 units
Product dimension	Height: 33.5mm Width: 81.4mm Length: 351.4mm
Installation options	Suspended mounting / Wall mounting/ Desktop Bracket
Connectivity	2x RJ45 Ethernet Ports
Power	Powered by DSP via POE
Color	White/Black
Packing List	1x A40 1x 10m UTP cable(Cat6) 1x Accessory package

## ● 1.2 AMX100 Introduction

NEARITY AMX100 DSP is a necessary component for the ceilingmic modes(A40/A50). Its rich interfaces support the connection of loudspeakers, PCs, wireless microphones, ACT10 controllers and other devices. At the same time, it can be compatible with traditional MCU conference rooms, and easily apply to various conference scenes.

### 1.2.1 AMX100 Features

#### - Flexible signal routing and connectivity

3.5mm analog audio in/out and TRS port to connect to room A/V conferencing system; USB-B port to connect to laptop or room PC; USB-C port to connect to additional microphone; phoenix ports to connect with loudspeakers, up to 8.

#### - Power over Ethernet (PoE) for the ceilingmics power supply:

Support up to 8 Nearity ceilingmics with Daisy-chain connection via POE

#### - Simple and quick to form a local sound reinforcement system

The AMX100 can connect local wireless microphones and passive speakers to form a simple and fast local sound reinforcement system, and transmit wireless microphone sound to the remote participants via USB.

### 1.2.2 AMX100 Physical Structure

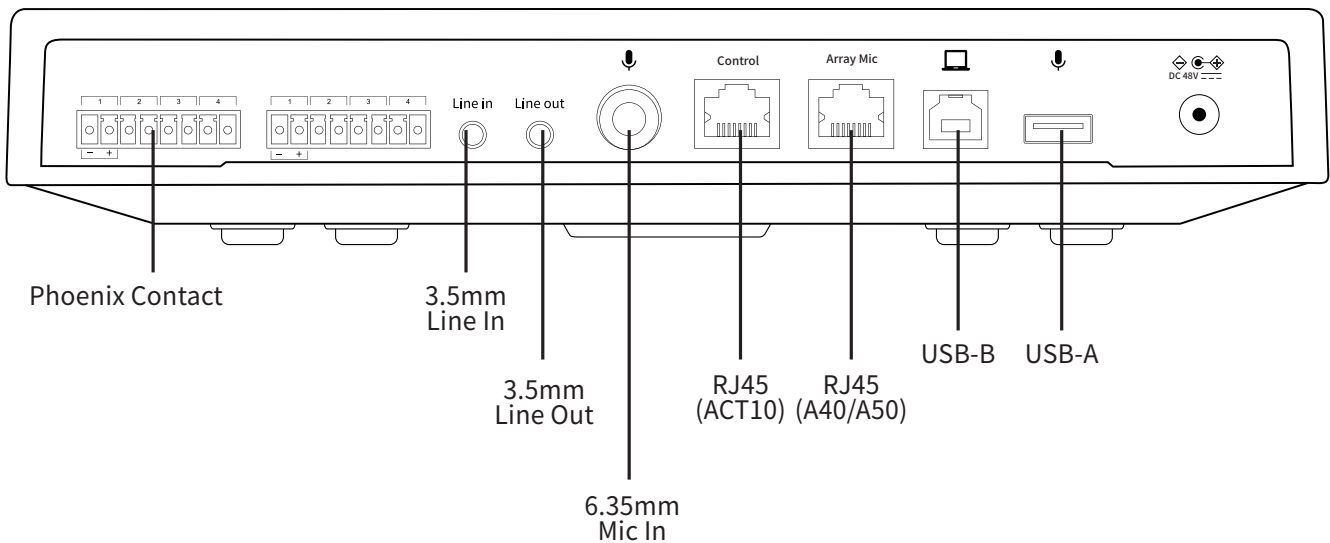

### 1.2.3 AMX100 Packing List

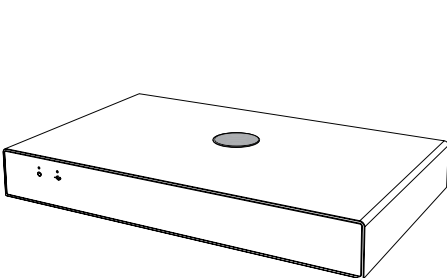

AMX100\*1

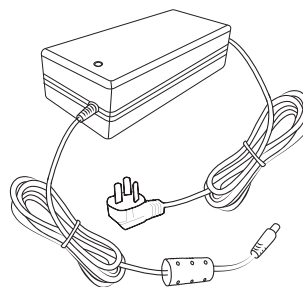

Power adapter\*1

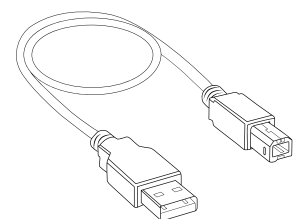

USB Type B to Type-A cable\*1

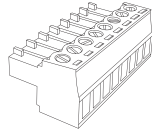

Speaker adapter\*2

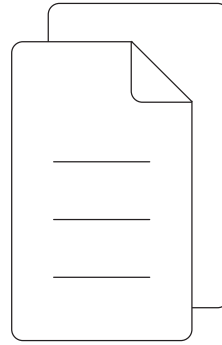

User Manual \* 1

---

## 1.2.4 AMX100 Key Specification

Power and Connectivity	Speaker Interface : Phoenix*8
	Line in : 3.5mm analog in
	Line out : 3.5mm analog out
	TRS : 6.35mm analog in
	Controller : RJ45 connect to ACT10
	Array Mic : RJ45 connect to Nearity ceilingmic, up to 8 via Daisy-chain
	USB-B : Type-B 2.0 connect ro PC
	USB-A : Type-A 2.0
	Power : DC48V/5.2A
	Reset : Reset button
Physical Characteristics	Dimension : 255.4(W) × 163.8(D) × 45.8(H)mm (10.05x 6.45x 1.8inches)

## ● 1.3 ACT10 Introduction

ACT10 is one of the accessories of the ceiling microphone system, which can be installed according to the meeting needs. ACT10 can intelligently control the corresponding ceilingmic device, quickly switch the volume up/down and mute on/off functions by touching the button, and support the one button mode to turn on/off local sound reinforcement mode.

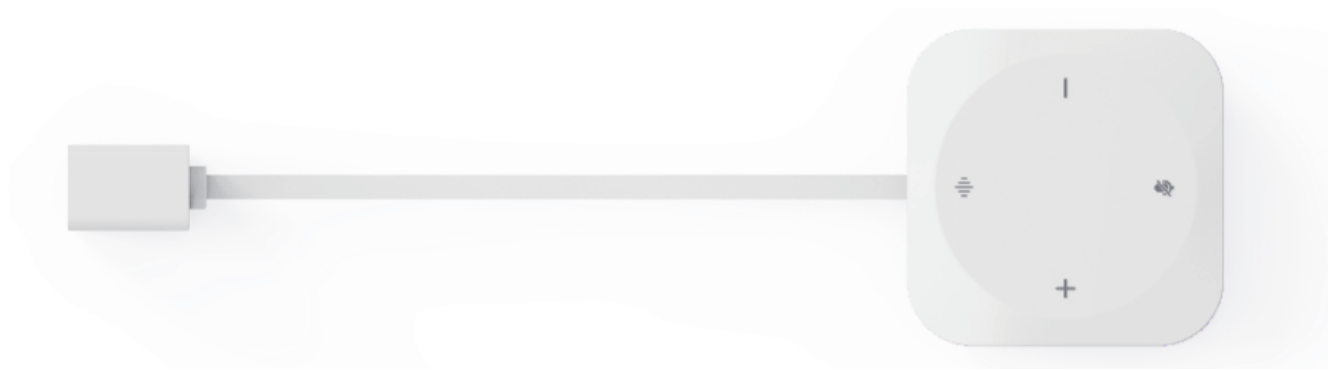

### 1.3.1 ACT10 Packing List

---

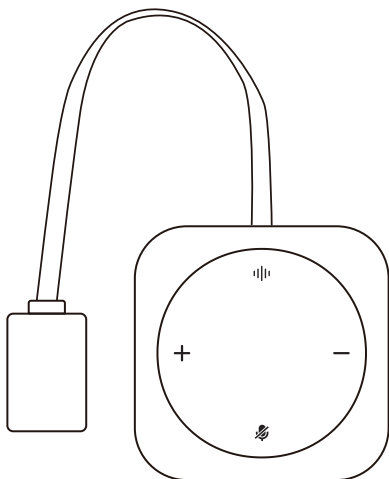

ACT10 \* 1

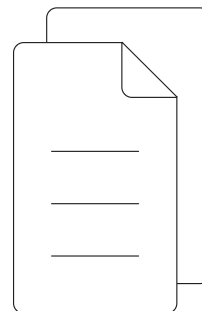

User Manual \* 1

### 1.3.2 ACT10 Connecting AMX100

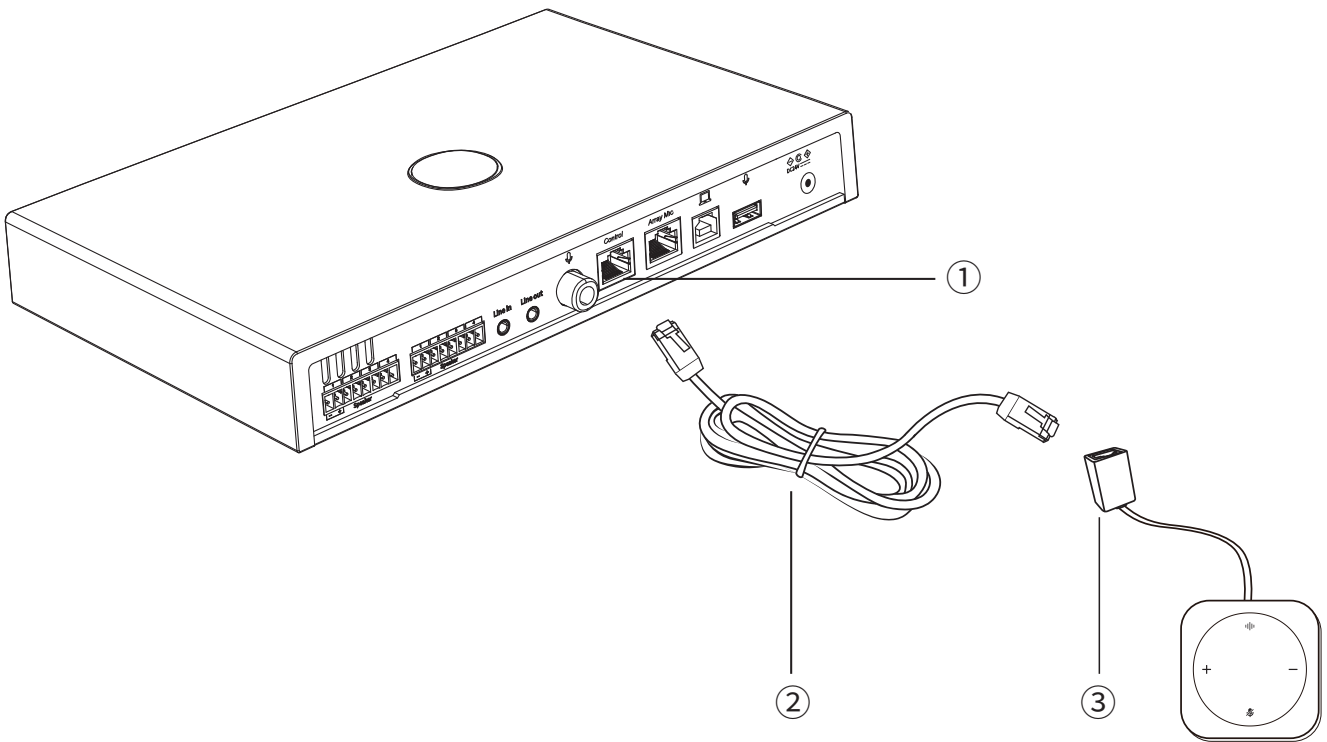

- ①RJ45(Control)
- ②Ethernet cable\*
- ③RJ45

\* Please purchase the corresponding length of Ethernet cable according to the needs of the scene.

### 1.3.3 ACT10 Key Specification

Product Information		
Desktop controller buttons	Volume+	Volume up
	Volume-	Volume down
	Microphone mute	Mute on/off
	Mode switch	Sound reinforcement/ Video conference
Desktop Controller Interface	RJ45	Connect to the DSP

## ● 1.4 ASP110 Passive Speaker Introduction

ASP 110 is a loudspeaker that provides enterprise sound in the room. By working with NEARITY DSP AMX 100, ASP 110 gives the best audio quality to any conference.

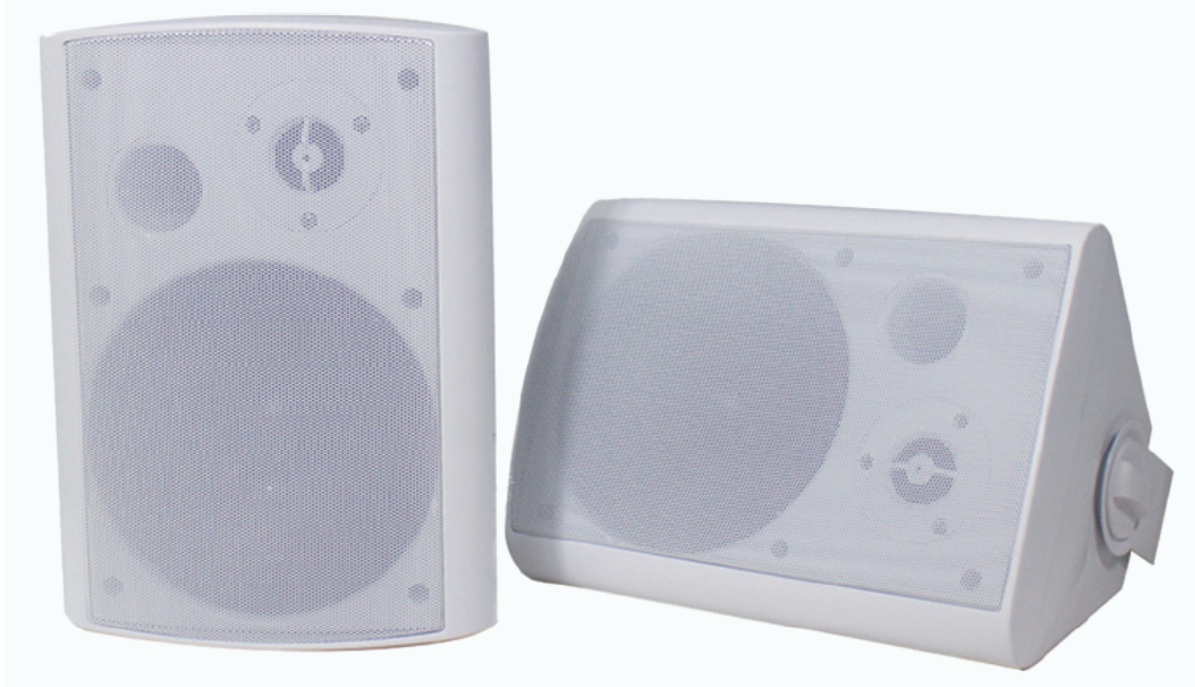

### 1.4.1 ASP110 Packing List

---

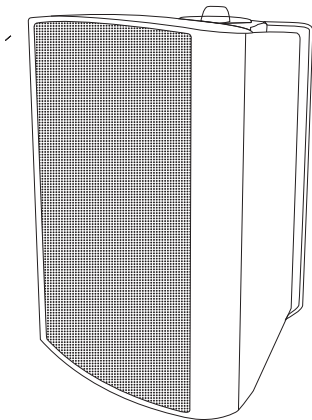

ASP110\*1

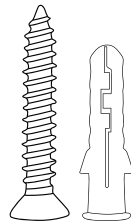

Screws\*2

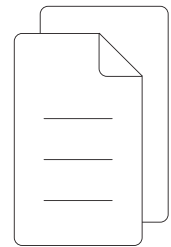

User Manual \* 1

---

## 1.4.2 ASP110 Connecting AMX100

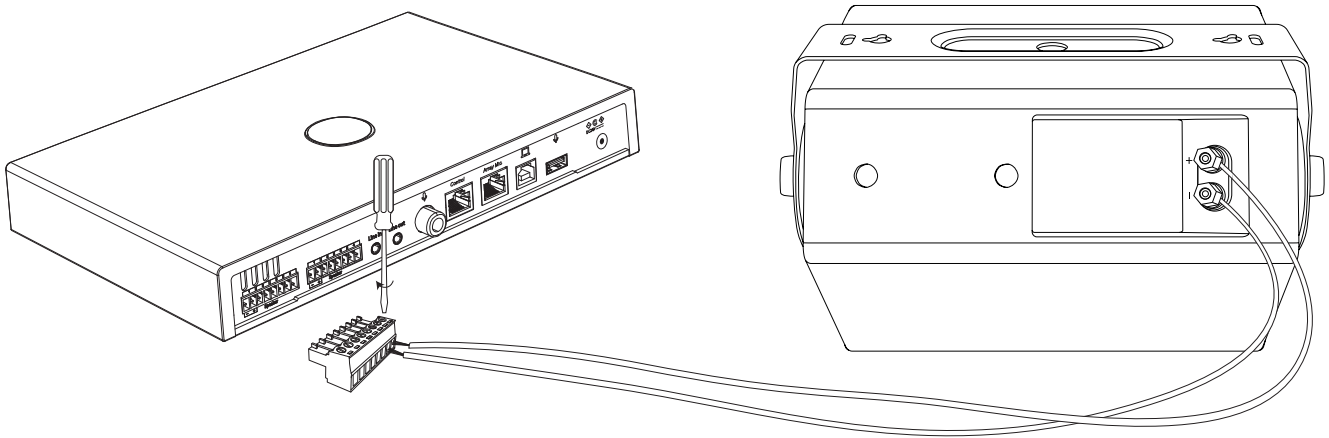

## 1.4.3 ASP110 Key Specification

Dimension	185(W)*167(D)*250(H)mm (7.28*6.57*9.84 inches)
Rated output power	15W
Effective frequency range	F0-20KHz
Volume	88±3dB @ 1m
THD	<5%

## 2. A40 System Deployment Instructions

### ● 2.1 Installation precautions

This product should be installed by a professional contractor. When determining the installation location and method, be sure to consider the applicable laws and ordinances for the area where the product is being installed.

Nearity assumes no responsibility in the event of accidents such as the product dropping due to insufficient strength of the installation site or improper installation.

When working in an elevated location, be sure to choose a stable location with no loose items on the ground before working.

Install the product in a location where there is no risk of the product being hit or damaged by the movements of nearby people or equipment.

Be sure to verify the strength of the installation location. The installation location should generally be able to handle at least 10 times the weight of the product.

Depending on the structure of the ceiling, vibrations may cause noise to be generated. Appropriate separate damping measures are recommended.

Be sure to use only the included accessories for installation.

Do not use the included accessories for any purpose other than for use with this product. Do not install the product in areas with exposure to high levels of oil or smoke, or where solvents or solutions are volatilized. Such conditions may result in chemical reactions that lead to deterioration or damage of the product's plastic parts, which may cause an accident such as the product dropping from the ceiling.

Do not install the product in areas where damage from salt or corrosive gas may occur. Such damage may reduce the strength of the product and cause an accident such as the product dropping from the ceiling.

Be sure to tighten the screws properly and completely. Failing to do so may result in injury due to an accident such as the product dropping from the ceiling.

Do not pinch the cables during installation.

Securely attach the seismic cable, zip tie, and safety belt in the specified location.

Attach the seismic cable so that there is as little slack as possible.

If the impact from a fall is applied to the seismic cable, replace the cable with a new one.

## ● 2.2 System connection

Compared with other products, the A40 product deployment is more complicated, which should be combined with other audio parts to work as a package, and needs to be integrated with the existing A/V system in customer conference rooms in many cases.

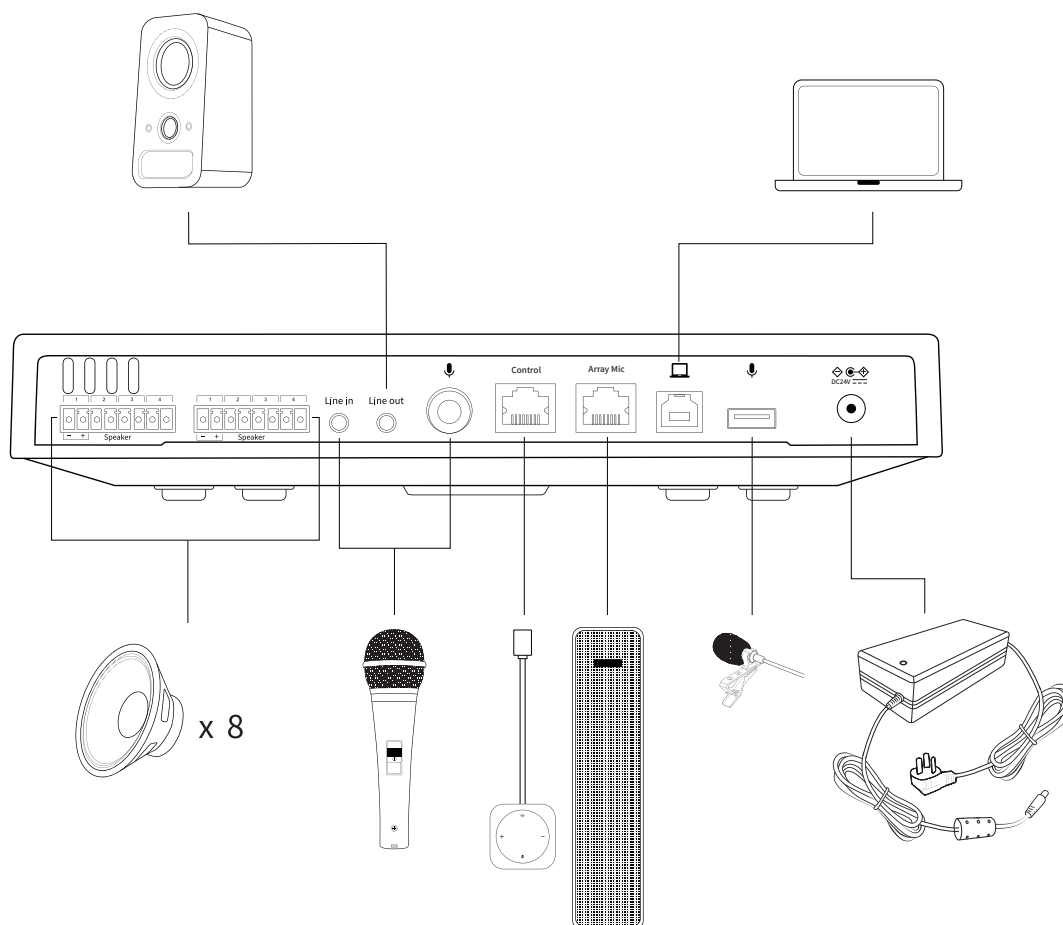

## ● 2.3 AMX100 Installation position/mode

Generally, AMX100 is installed behind the TV, under the conference table, in the cabinet, etc. However, as AMX100 is the HUB node of each component of the A40 package, it involves:

- Network cable length and cabling mode with multiple A40s.
- Audio cable length and wiring mode with multiple wall mounted louder-speakers ASP110.
- Length and cabling method of USB cable with conference host terminal/smart white-board OPS/speaker's laptop.
- Length and cabling mode of audio cable integrated with equipment in A/V cabinet (if there's 3rd party A/V system integration).
- The length and cabling mode of the audio cable integrated with the traditional video conference terminal (if there's 3rd party conference system integration).

Therefore, it is necessary to consider and determine the installation location of the AMX100 by integrating the above factors.

### 2.3.1 Cable length/cabling

The new AMX100 is equipped with a power adapter with a power cord, and a 3-meter USB cable from USB-B to USB-A.

To connect with ACT10, should buy extra network UTP cable.

To connect with ASP100/110 Speaker, should buy extra speaker cables.

If the conference host terminal/speaker's laptop is far away from the AMX100, then need to consider purchasing additional USB extension cables or transferring via the ground plug network.

### 2.3.2 Adapter/auxiliary materials

When connecting with A/V system (audio processor/mixer/handheld microphone receiver) and hardware video terminals, the AMX100 side will use unbalanced 3.5 audio interfaces and 6.35 audio interfaces. But the other side is usually a balanced Canon interface and Phoenix terminal interface. Therefore, additional 3.5/6.35 XLR, 3.5/6.35 Phoenix terminal and other conversion cables need to be prepared (pay attention to male and female at both ends).

In addition, due to strong electric magnetic leakage, quality of interconnecting cables, potential difference between two devices and other factors, unbalanced signals are easily to get interference and generate current noise. In this case, it is necessary to purchase a noise eliminator isolator to be connected in series in the interconnection cable to solve the problem of current noise.

PS: The 6.35mm input port will be designed to balanced type the next batch of production.

## ● 2.4 Installation of A40 Unit

### 2.4.1 Power supply of A40

A40 is a non-standard PoE power supply mode. The RJ45 port of the AMX100 directly supplies power to multiple A40s, eliminating the need to reserve strong electricity for them in the ceiling.

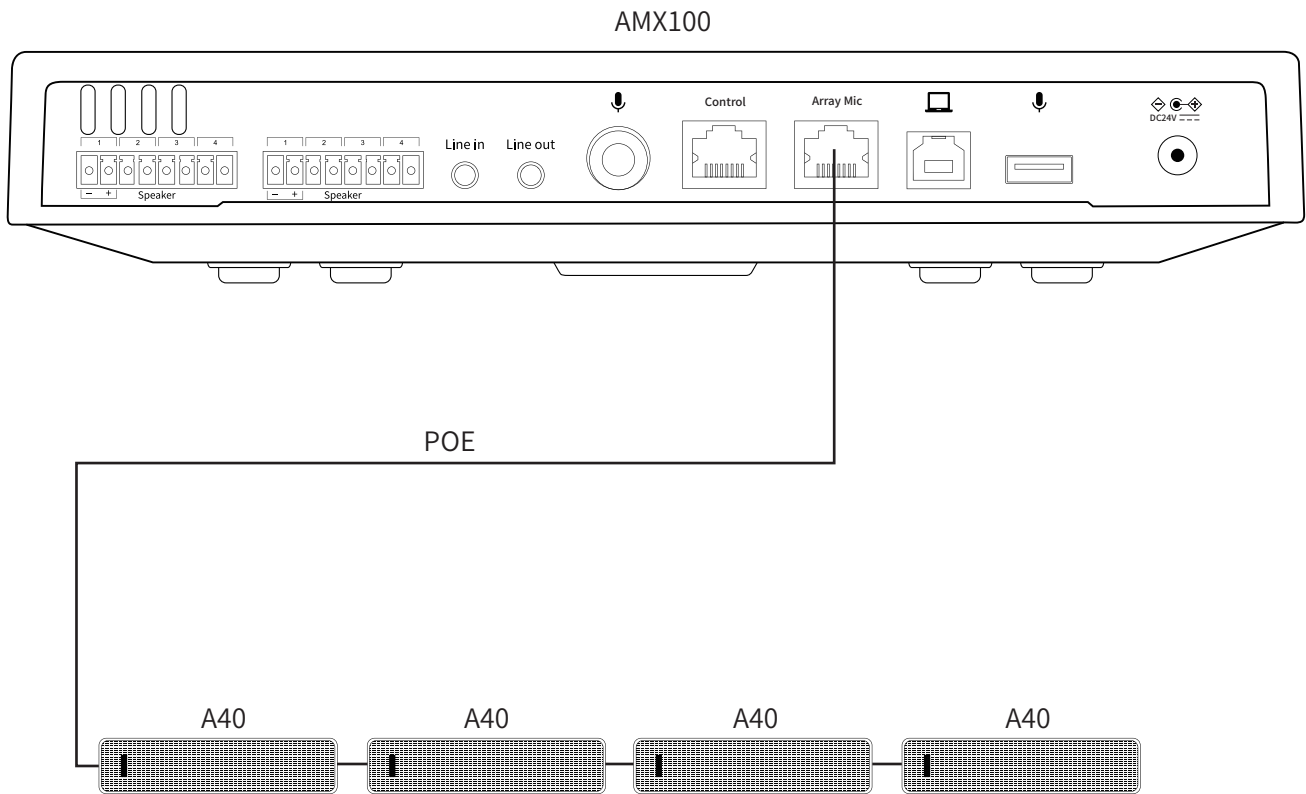

\* A40 Daisy Chain, up to 8

### 2.4.2 Cable length/cabling

The AMX100 is equipped with a 20-meter Cat6 network cable as standard, which is used to connect the first A40.

Each A40 is equipped with a 10-meter Cat6 network cable as standard, which is used to connect the subsequent A40.

The length of the standard AMX100/A40 network cable can meet the requirements of common conference room space. If the cable length in the package is not long enough for some super large conference space, then we can use longer Cat6 and above network cables (well-known brand). Before using the network cable, the line sequence must be tested with a line measuring instrument.

As we tested, AMX100 support maximum 8 units of A40 cascaded by 8 20-meter Cat6 network cables with all functions work normally.

## 2.4.3 Installation mode of A40 Unit

### • Wall Mounting

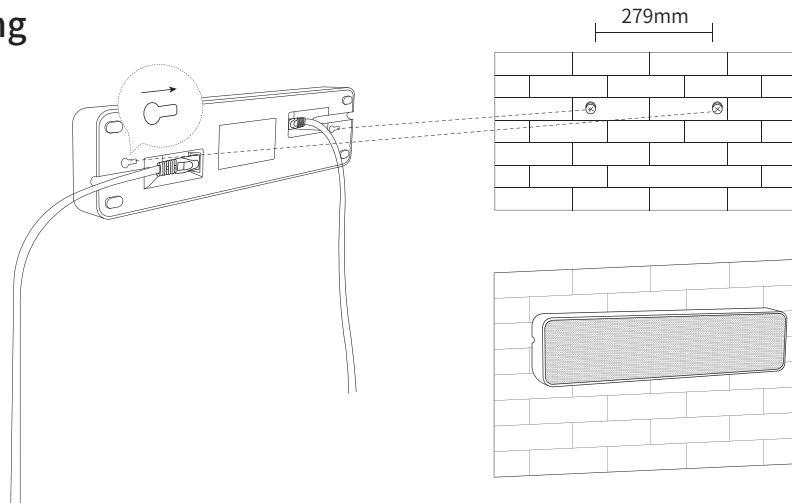

It's recommended to install the A40 1.5~2.0m when wall mounted.

### • Ceiling Mounting

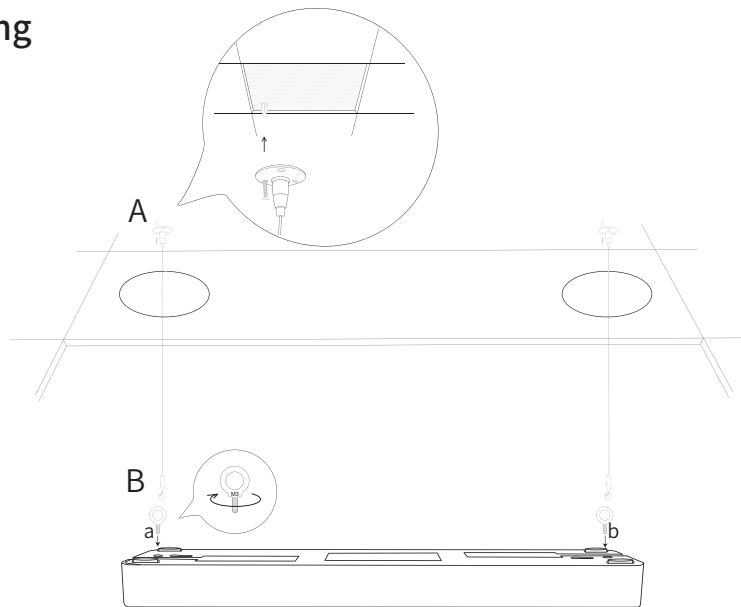

It's recommended to install the A40 2.0~2.5m when wall mounted.

### • Desktop Positioning

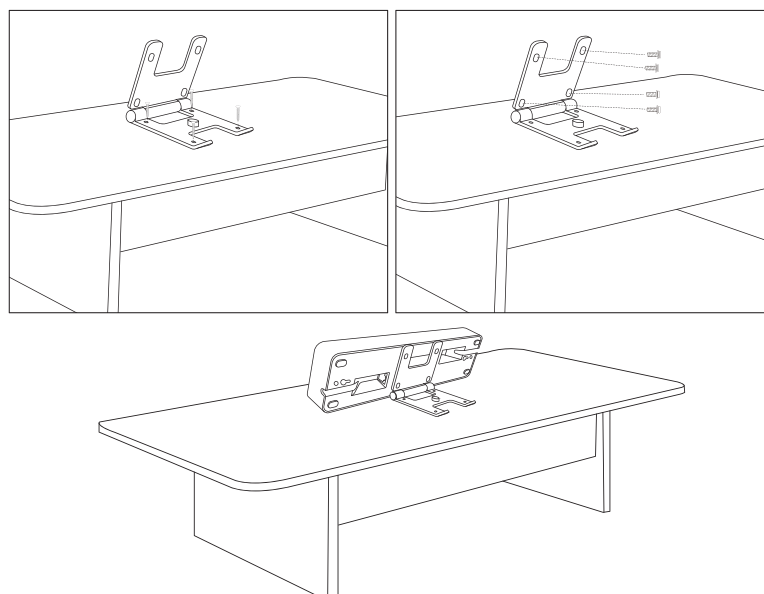

## 2.4.4 A40 Indicators

- Yellow-green light: device power on
- Blue and white light flashes slowly: Device in upgrading
- Pure red light: Device Muted
- Blue-green light: Device in hybrid mode
- Remote Meeting mode: Blue and white light: Device in remote meeting mode
- Solid blue light: Device in local sound reinforcement mode

## ● 2.5 Deployment of ASP110

### 2.5.1 Power supply of ASP110

ASP110 is a wall mounted loudspeaker, passive 4Ω/15W. It is not recommended to use a third-party speaker. If really need use third-party speaker, it must meet the passive 4 Ω/15W specification.

### 2.5.2 Cable length/cablings

#### Network cable length

ASP110 is equipped with a 25m audio cable as standard. If the length of the standard 25m audio cable is not enough for the actual customer's conference environment deployment, you can purchase the audio cable by yourself.

#### Laying and cabling

The audio cable shall be wired in the pipe slot in the ceiling and wall, and shall not be wired together with the strong current cable, which is easy to cause electromagnetic interference and generate current noise.

### 2.5.3 Wiring mode

ASP110 wiring mode is using audio terminal, red terminal is positive (+), black terminal is negative (-); The AMX100 side is the Phoenix terminal wiring mode. When facing to the Phoenix terminal, the left side is positive (+) and the right side is negative (-). The specific wiring diagram is as follows:

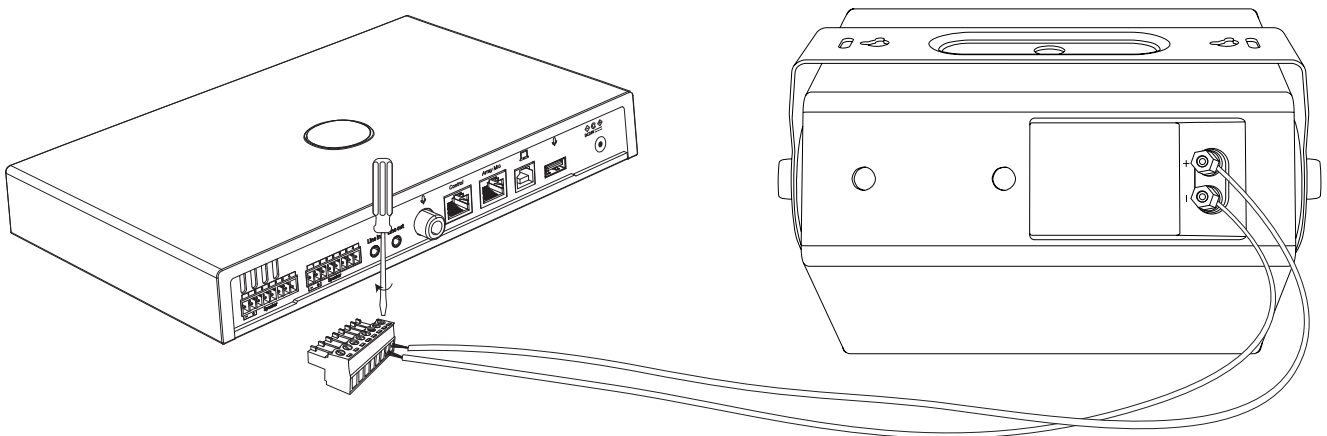

Before installation, please prepare suitable screwdriver, scissors or wire stripper in advance.

## 2.5.4 ASP110 Installation height/angle

### Installation height

ASP110 wall mounted loudspeaker shall be installed as high as possible (if the installation height can be same with the A40 horizontal height, that will be better). To avoid the pickup beam range of A40, the loudspeaker shall be as far away from the A40 beam as possible.

### Installation angle

ASP110 wall mounted speaker has its own wall mounted parts, which can be rotated left and right (vertical mounting) to adjust the angle or up and down (horizontal mounting) to adjust the angle.

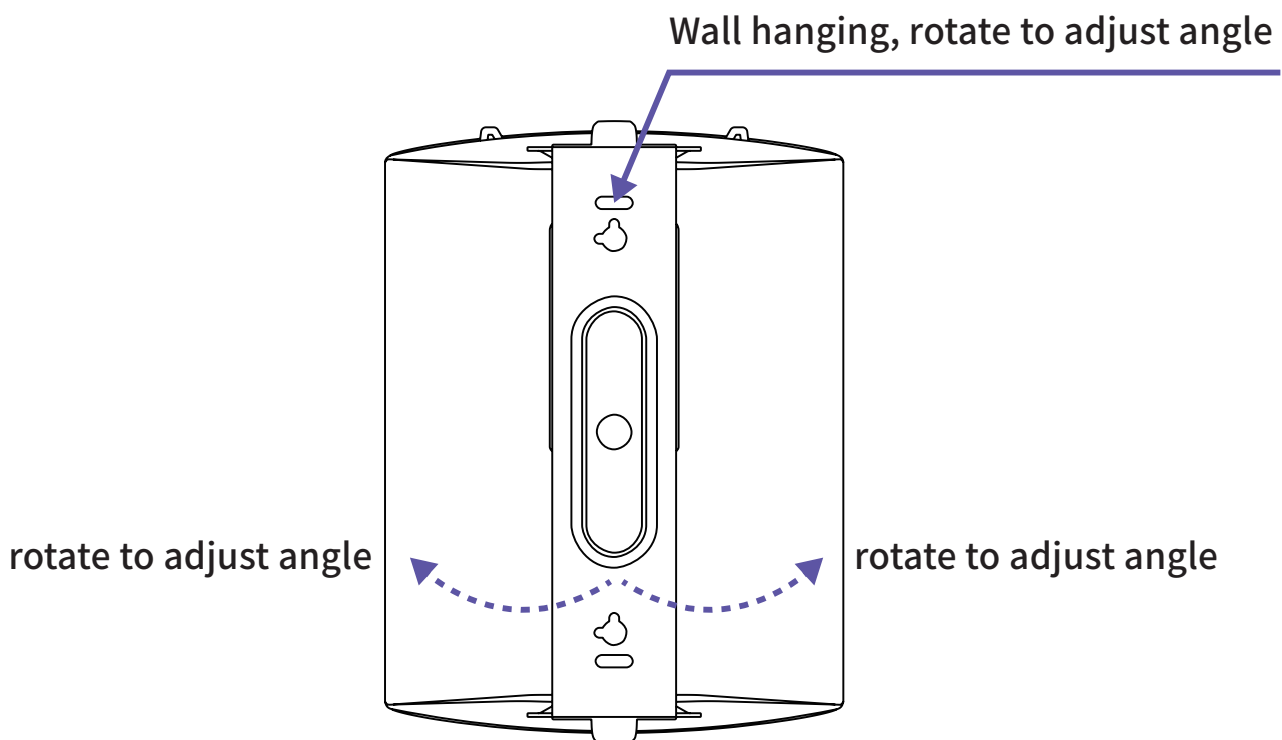

When the ASP110 is installed at the same height as the A40, in the vertical mounting mode, sometimes it is hoped that the audience will have a better voice experience, so speaker should be tilted downward for sound reinforcement. However, the angle cannot be adjusted downward in the vertical mounting mode, and other installation accessories need to be purchased.

The ASP110 speaker should not face to the A40. Especially in the local sound reinforcement scene, the A40 should not be deployed between the ASP110 speaker and the audience. In that case, the ASP110 speaker is faced to the A40 directly, which is not correct.

## ● 2.6 ACT10 Installation

### 2.6.1 Connection with AMX100

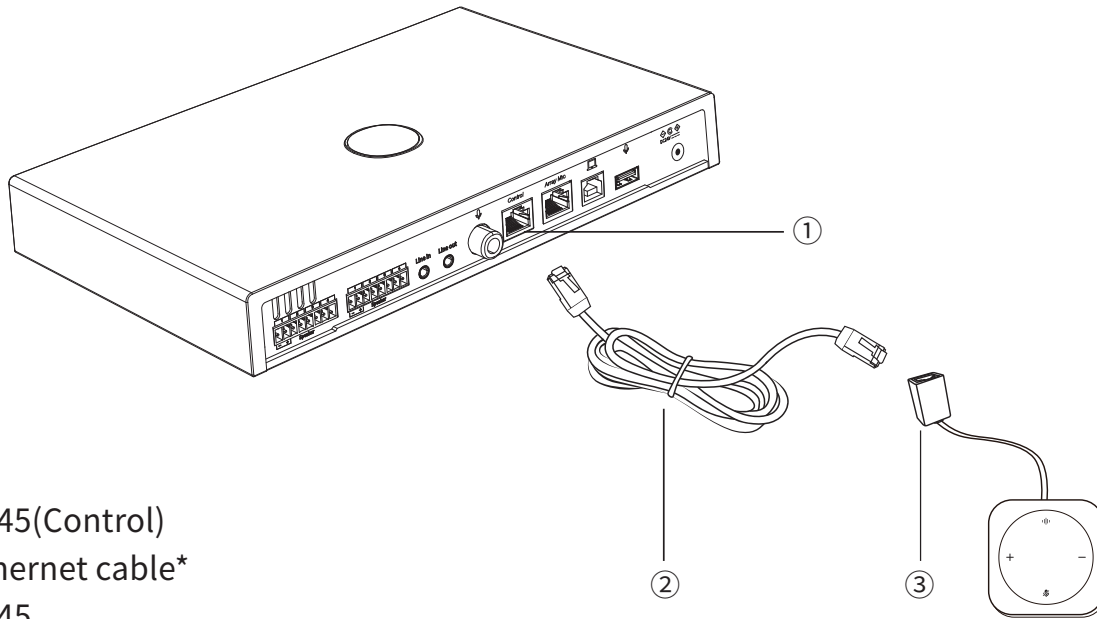

- ①RJ45(Control)
- ②Ethernet cable\*
- ③RJ45

\* Please purchase the corresponding length of Ethernet cable according to the needs of the scene.

ACT10 is designed with POE technology. When connected to the AMX100, the ACT10 powers on. The corresponding functions of the system can be controlled via the buttons on the ACT10 (which can be defined on the Nearsync tool).

### 2.6.2 Indicators

- Yellow-green light: device power on
- Blue and white light flashes slowly: Device in upgrading
- Pure red light: Device Muted
- Blue-green light: Device in hybrid mode
- Remote Meeting mode: Blue and white light: Device in remote meeting mode
- Solid blue light: Device in local sound reinforcement mode

## ● 2.7 3rd A/V system integration

If the A40 must be integrated with the customer's existing A/V system in the project, it is recommended that the A40 package only be used as the pickup side, instead of deploying ASP110 speakers, use the existing speakers in the A/V system for sound reinforcement. The main considerations are as follows:

- For A40, remote conference mode shall be adopted as more as possible. If local sound reinforcement is necessary, we recommend to use handheld microphone to make sound reinforcement instead of A40;
- The sound reinforcement is on the A/V system side, so the audio output is on the A/V system side. The A40 package side saves a lot of trouble, such as the subsequent local sound reinforcement, the audio routing problems when the computer audio and video material is sharing (under the local conference or remote conference), the current noise

of speaker, and the consistency problem of the volume when there are multi-channel audio streams go to the loudspeaker for sound reinforcement, etc..

Precautions for A/V system integration are also mentioned in previous chapters, mainly including:

- Sound insulation and noise elimination device is used to eliminate electric current noise;
- Pay attention to the specifications of audio connecting cable connectors, especially male and female;
- Pay attention to the design and planning of audio routing to avoid echo;
- Pay attention to the realization of audio flow direction and switching in two scenarios when audio playback scenario when the audio and video materials on the speaker's laptop are shared and played: 1, In the local conference (without turn on the conference terminal); 2, In the remote conference (with the conference terminal holding the remote conference).
- The A40/AMX100 does not support central control, scene configuration switching, and there is no solution temporarily for complex changing conference room scenarios (such as switching 3 small conference rooms to one big conference room).

## 3. Operation on Software-Nearsync Configuration

### • 3.1 Download and Installation of Nearsync

Download the Nearsync on the official website. <https://nearity.co/resources/dfu>

The image shows a screenshot of the Nearsync website and its software interface. The website header includes the Nearsync logo and navigation links: PRODUCTS, SOLUTIONS, SOFTWARE, PARTNERS, RESOURCE, COMPANY, Blog, and Contact Sales. The main content area features the heading "NEARSYNC" and a sub-heading: "We offer video conferencing devices management software, with the capability to support hybrid and remote workforces." Below this are two buttons: "GET STARTED NOW" and "WATCH VIDEO". A link "Already have an account? Sign in" is also present. The software interface is displayed on a laptop screen, showing a "NearSync" window with a "V5200 / Device Info" section. The interface includes a sidebar with a "Room" list containing "V415", "V5200", and "A11". The main content area shows a device icon and the following information: Device Name: V5200, Device Type: Camera, Firmware Version: V1.100.0.6.R.230210, and Serial Number: AW27G5A8EA00M0047.

# Install NearSync

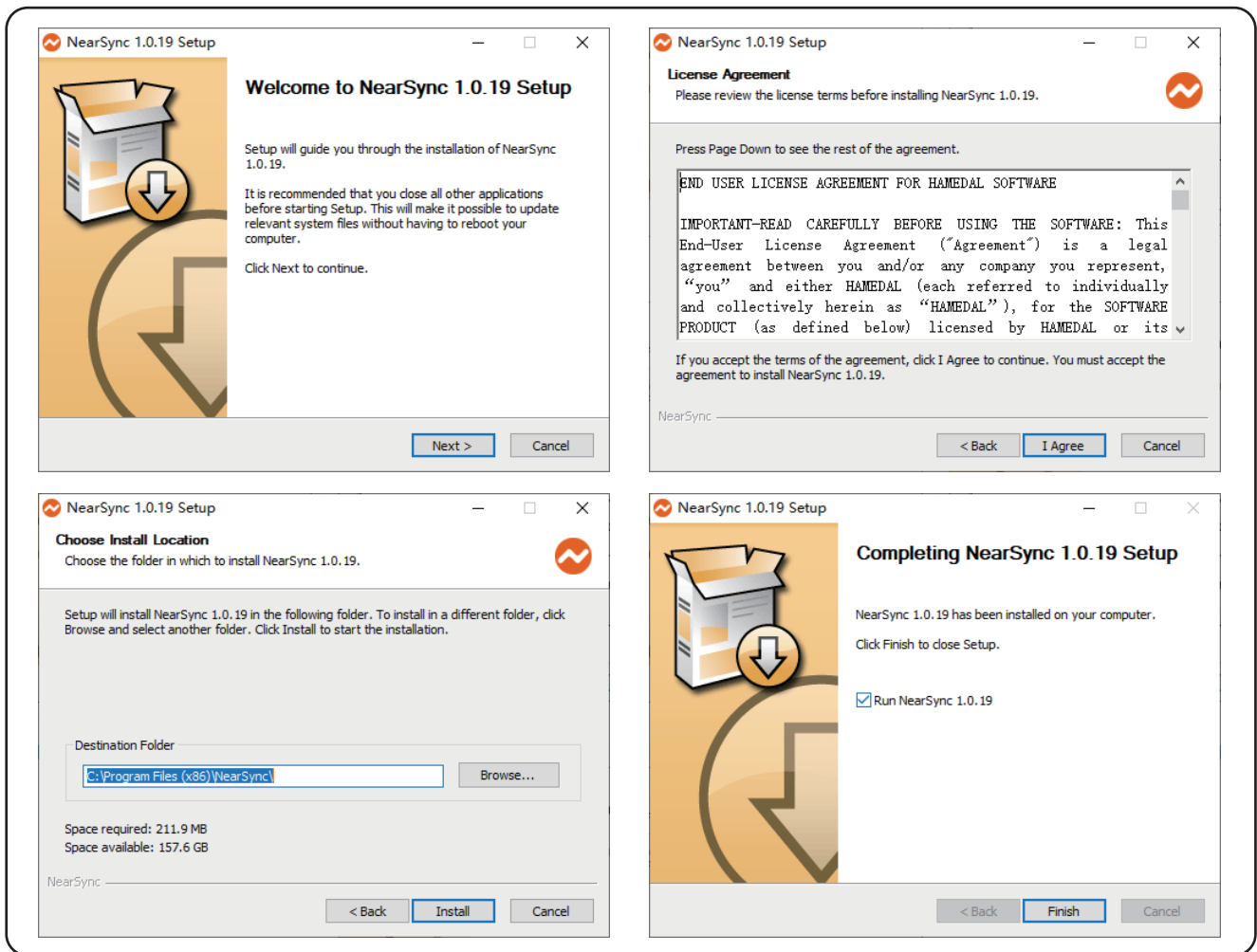

## ● 3.2 Software Configuration

### 3.2.1 NearSync Main interface instruction

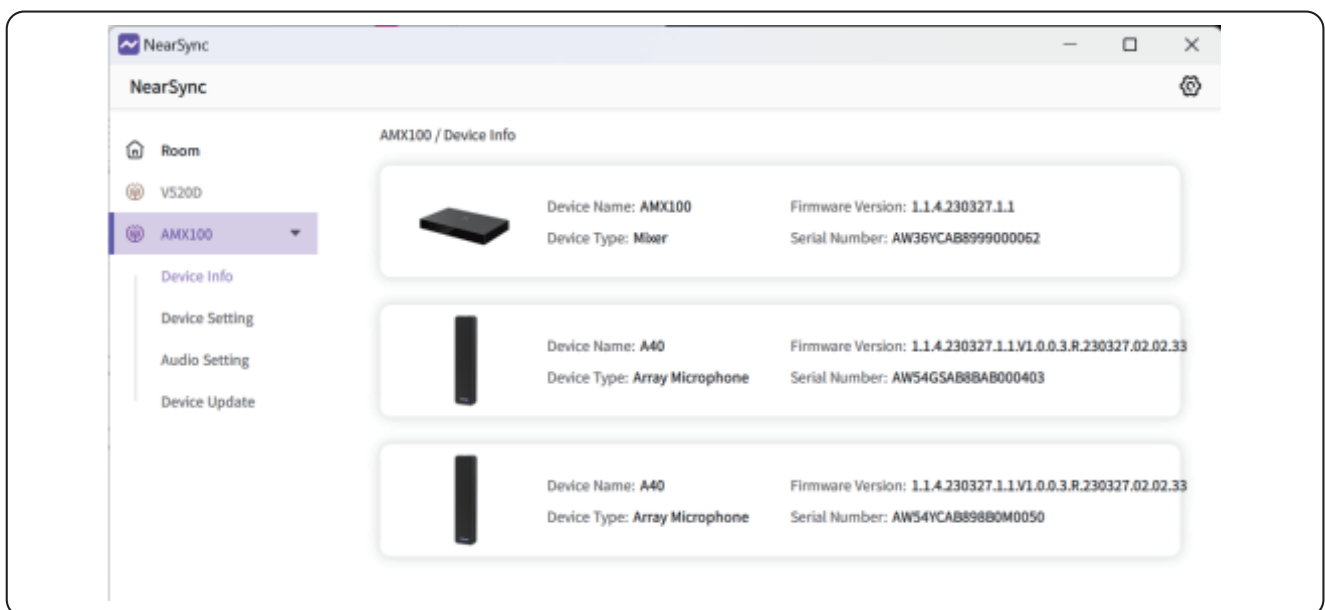

It will show the device info in this page. If there are multiple A40s daisy-chained, you can distinguish by the SN.

## 3.2.2 Device Setting

### 3.2.2.1 A40 Setting

Click A40-1 to set A40. if there are multiple A40s daisy-chained, select the corresponding A40.

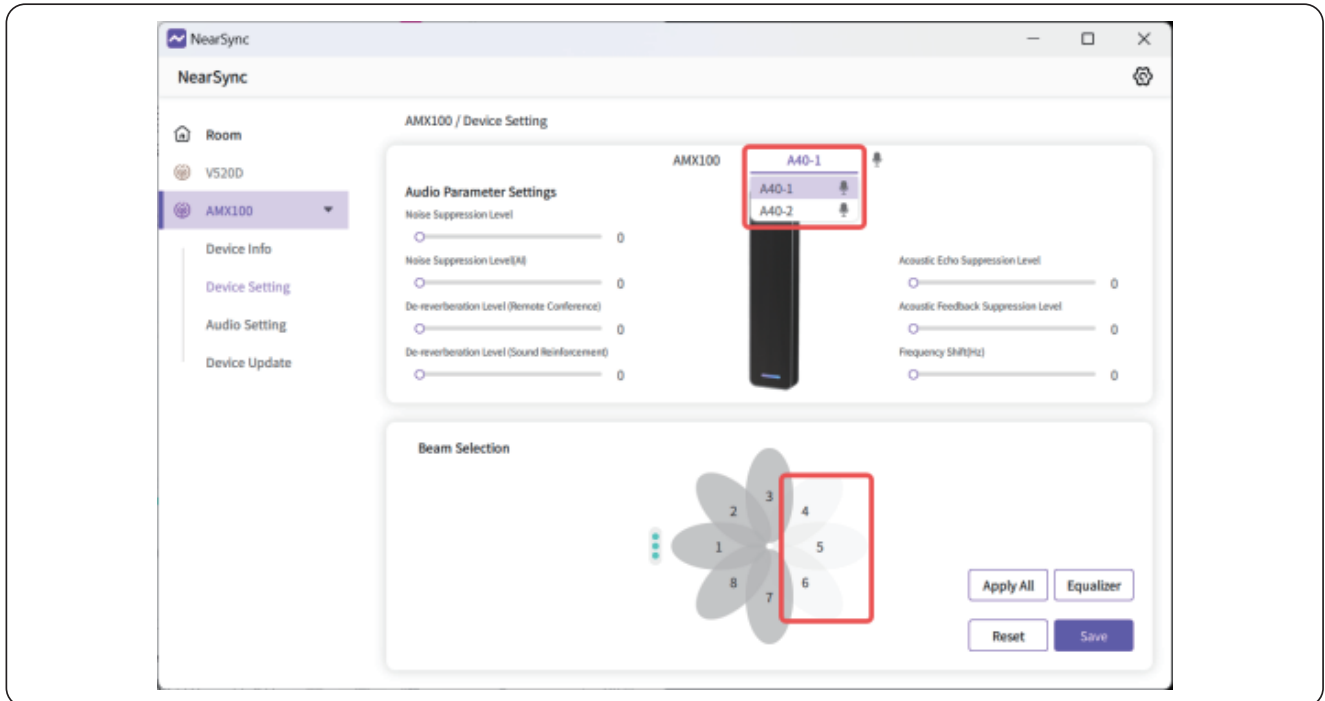

### Parameter Settings

#### Beam Selection

The beam selection can determine the corresponding direction and beam according to the icon position of the light. A total of 8 beams can be selected. If selected (as showed in the picture 4,5 and 6 selected, color turned to white), it means the beam is disabled, otherwise it means it is working normally (in gray color).

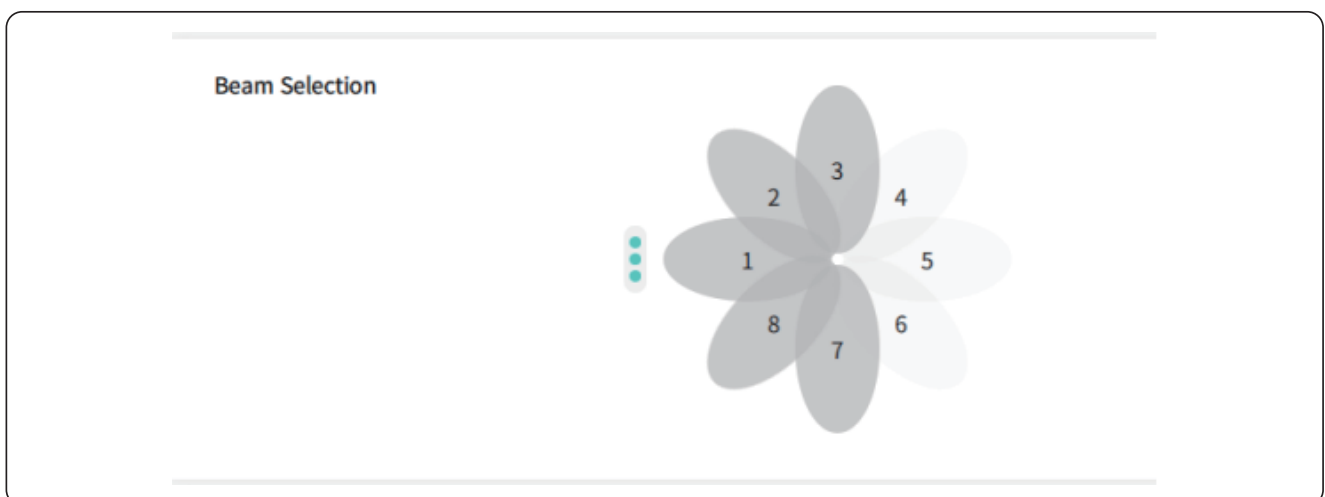

### Audio Parameter Settings

Noise Suppression level: this is to suppress the normal background constant noise. the value is 0-100, the larger the value, the higher the noise suppression level.

Noise Suppression level(AI): this is to suppress the normal background non-constant noise. the value is 0-100, the larger the value, the higher the noise suppression level.

Echo Cancellation level: the value is 0-100, the larger the value, the higher the noise suppression level.

De-reverberation level(remote conference): used in remote conferencing mode, the value is 0-100, the larger the value, the higher the de-reverberation level.

De-reverberation level(sound reinforcement): used in local sound reinforcement mode, the value is 0-100, the larger the value, the higher the de-reverberation level.

### Audio Parameter Settings

Noise Suppression Level

80

Noise Suppression Level(AI)

0

Echo Cancellation Level

0

De-reverberation Level (Remote Conference)

10

De-reverberation Level (Sound Reinforcement)

30

### A40 Selection

When there are multiple A40s, select A40 through the drop-down box and make corresponding settings.



AMX100

A40-1

A40-1

A40-2

## Mute Settings

Check the mic icon,  means muted.  means in use.

## Equalizer

The equalizer is used to adjust the voice effect at different frequency.

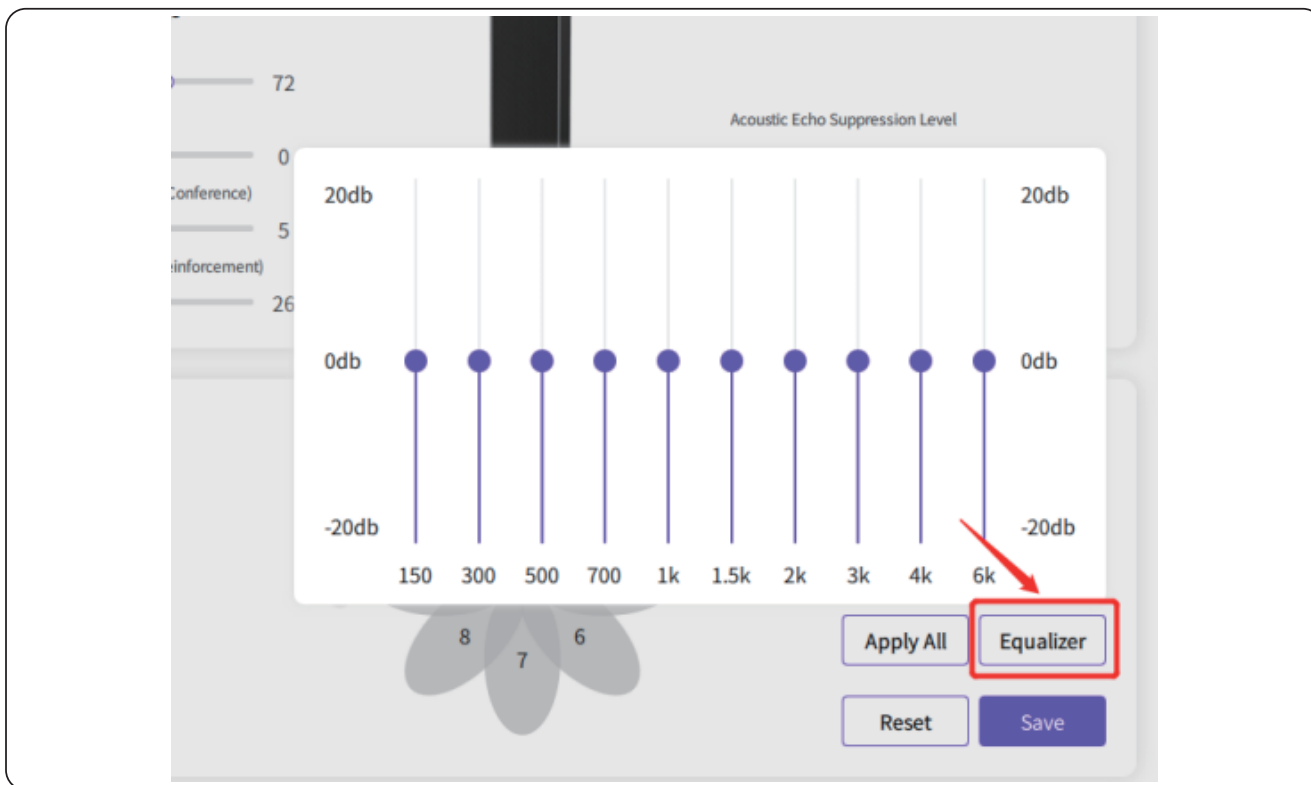

## 3.2.2.2 Audio Settings

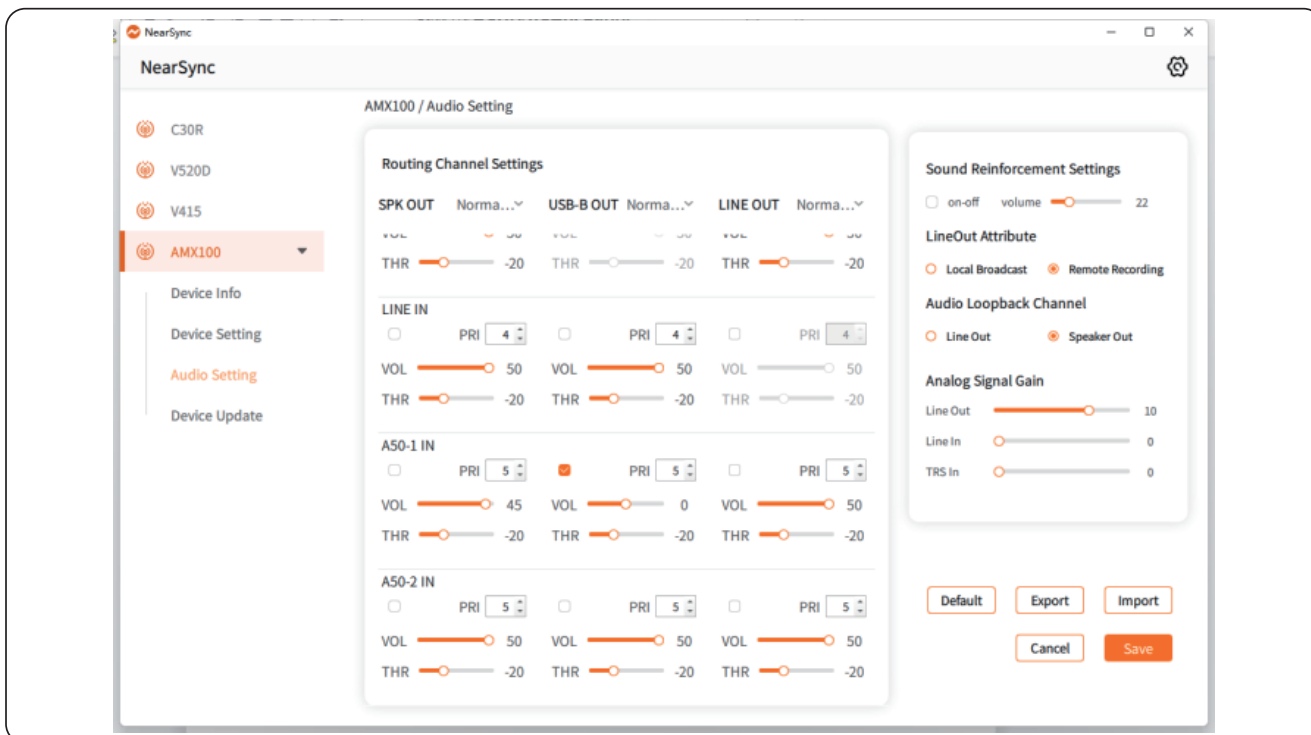

The parameters set in this interface are stored permanently and will not be changed after power off.

## Routing Channel Settings

### Routing Mode

Each output can select the routing mode individually. The current Speaker Output and USB-B Output both support normal mode and priority mode. Line Out Output only supports normal mode for the time being.

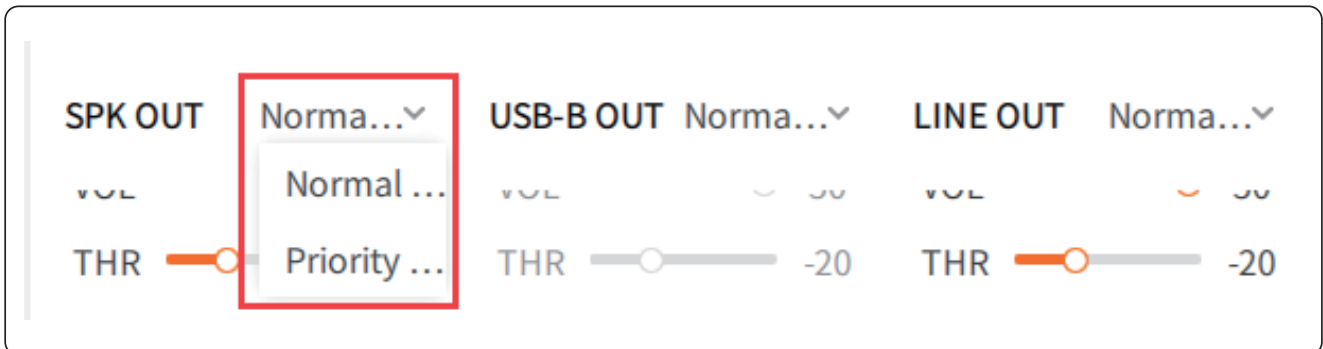

### Normal Mode

Mix the selected multi-channel audio inputs indiscriminately and pass it to the output interface.

### Priority Mode

As shown in the figure above, relevant parameters such as priority and threshold are calculated corresponding to each input. The priority range is 0-16, and priority 0 is the highest priority. It is not recommended to use the same priority for multiple inputs.

The selection logic is to perform polling according to the priority 0-16. When the input energy corresponding to a certain priority is greater than the threshold, the audio input of this channel is passed to the output, and when all channels do not reach the threshold, no output is performed.

### Input Parameters

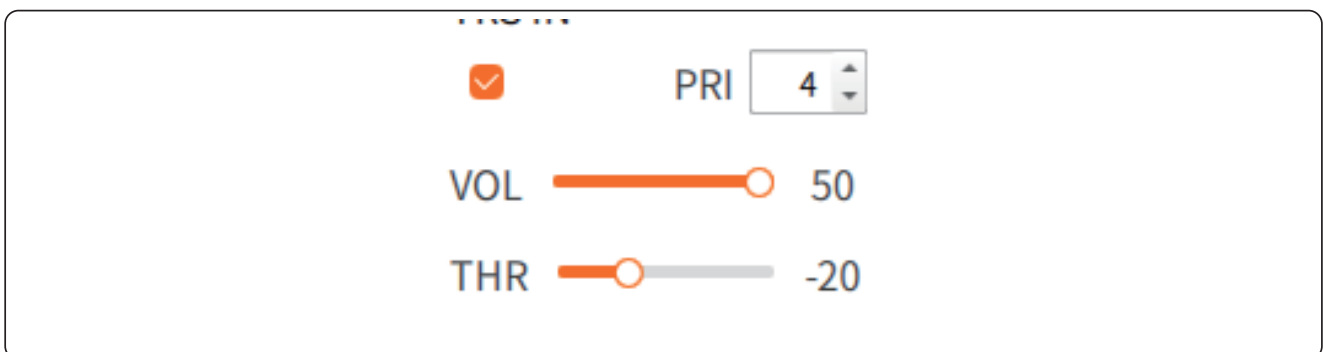

Volume: The adjustment range is 0-50, of which 50 is the default value, which means the volume will not be adjusted. Please note the change is digital adjustment, and it is not recommended to adjust too much. In addition, the volume adjustment is independent of each output. For example, adjusting the TRS input volume of Speaker Output will not affect the TRS input volume of USB-B Output.

Check box: Check the box means to pass the audio input to the corresponding output

Priority: Only take effect in priority mode, the value is 0-16, 0 means the highest priority, 16 means the lowest priority.

Threshold: Only valid in priority mode, the value is -20 by default, value range -50~50, the unit is dB.

### Sound Reinforcement Settings

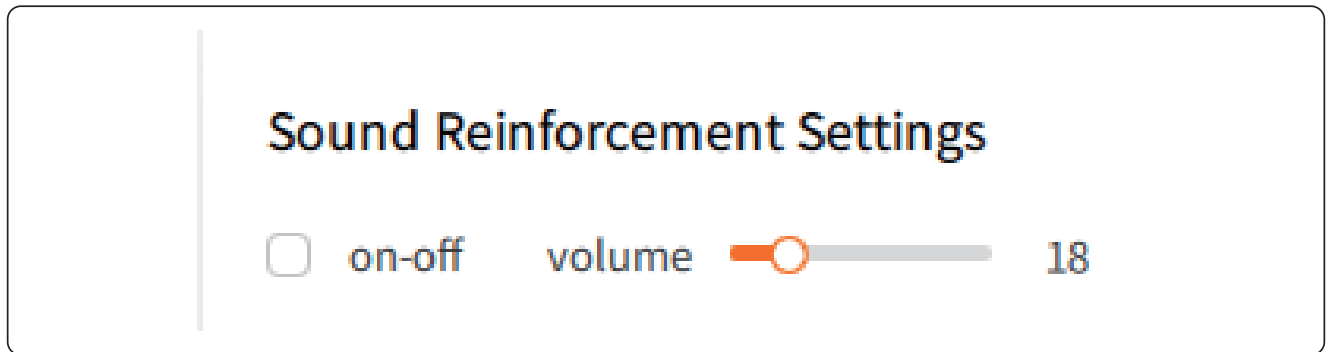

Check box: Check the box means enable sound reinforcement.

Volume: the value is 0-100

### Line Out Attribute

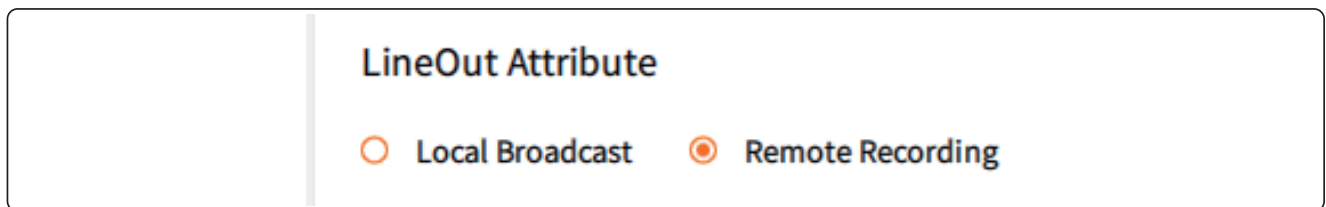

Local broadcast: suitable for connecting to a local amplifier for audio playback, the sound picked up by A40 will be processed accordingly

Remote recording: suitable for connecting to the traditional audio meeting server, the sound is transmitted to the far end

### Analog Signal Gain

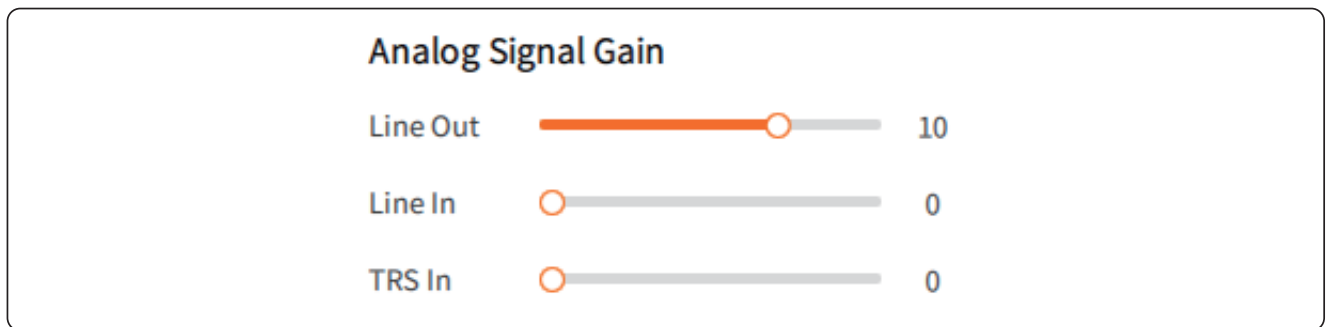

There are three analog audio interfaces on the DSP, and the analog audio gain can be set as follows:

Line Out: The value is 0-14, where 10 represents 0dB, and the downward and upward changes are 5dB respectively.

Line In: The value is 0-14, where 0 represents 0dB, and the upward change is 2dB

TRS Input: The value is 0-14, where 0 represents 0dB, and the upward change is 2dB

### 3.2.3 Device Update

#### Online update

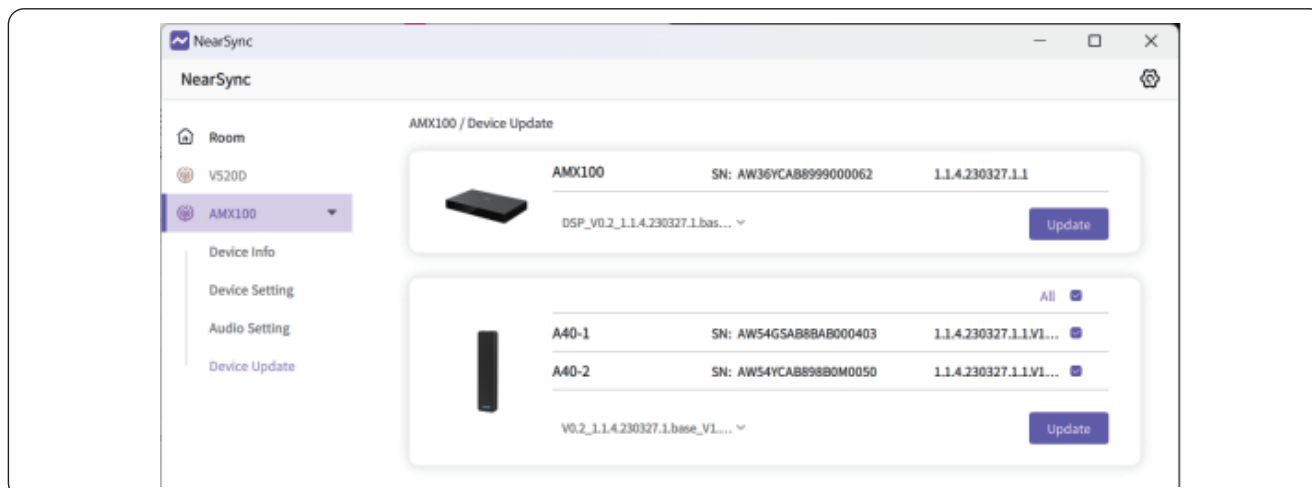

It will show the latest firmware version under each mode. Click “update” to start updating.

#### Local update

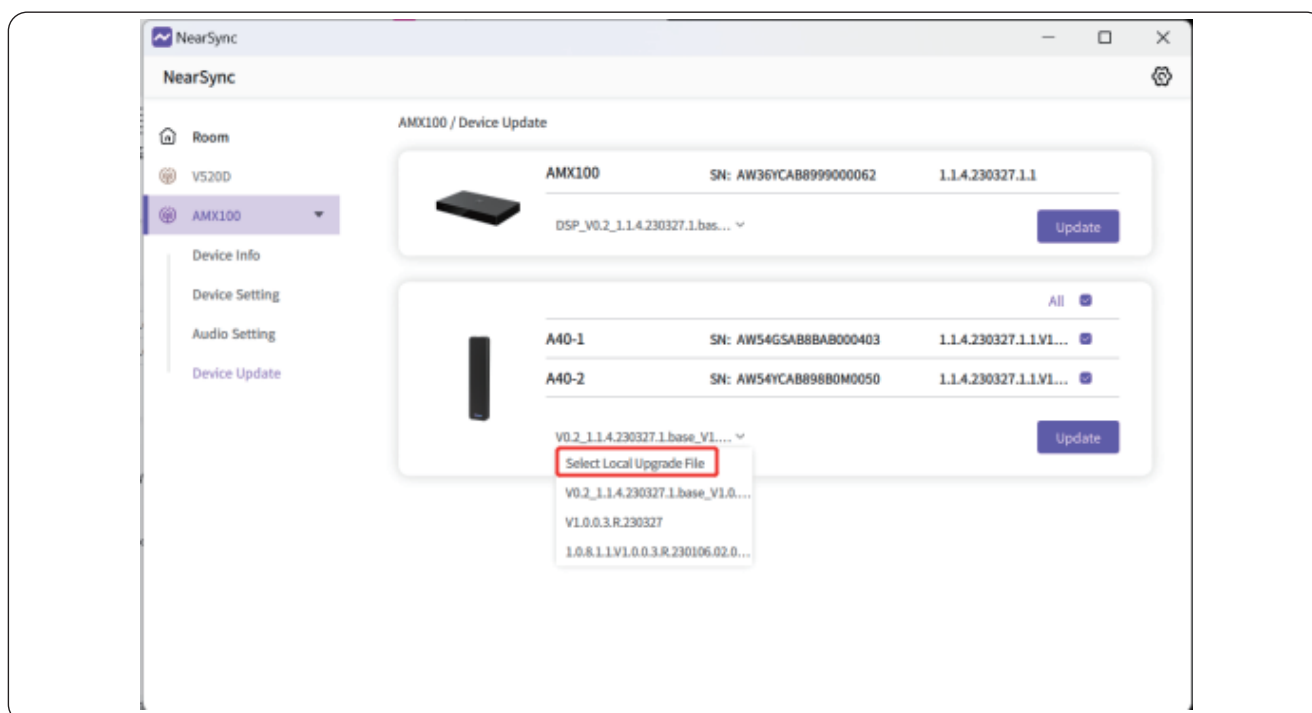

Before local update, contact Nearity team to confirm the firmware version.

1, select local upgrade file

2, click “update” to choose the bin file on your PC/laptop, and then it will start updating.

## 7. FAQ

### Q: What loud-speaker can we use to pair with ceiling Mic A40?

A: Nearity louderspeaker ASP110 and ASP100 are available. You can also use 3rd party louder-speaker to connect with AMX100 DSP for the audio routing.

---

### Q: Does A40 Supported connecting with 3rd party DSP?

A: Does A40 Supported connecting with 3rd party DSP?

---

### Q: Why I cannot find Nearity A40 in the VC software microphone list?

A: The A40 is connect to AMX100 and then do the audio routing. So we should choose AMX100 while we use the A40 system.

---

### Q: What's the insallation height of A40 for ceiling mouting?

A: It depends on the room side. Generally we recommand to install the A40 range 2.5~3.5 meters to the ground.

## 8. Caution

Although this product was designed to be used safely, failing to use it correctly may result in an accident. To ensure safety, observe all warnings and cautions while using the product. The product is intended for commercial use, not for general use.

Disconnect the product from a device if the product begins to malfunction, producing smoke, odor, heat, unwanted noise or showing other signs of damage. In such a case, contact your local Nearity supplier.

- Do not disassemble, modify or attempt to repair the product to avoid electric shock, malfunction or fire.
- Do not subject the product to strong impact to avoid electric shock, malfunction or fire.
- Do not handle the product with wet hands to avoid electric shock or injury.
- Do not allow the product to get wet to avoid electric shock or malfunction.
- Do not put foreign matter such as combustible materials, metal, or liquid in the product.
- Do not cover the product with a cloth to avoid fire or injury by overheating.
- Keep the product out of the reach of small children. The product is not intended for use around children.
- Do not place the product near fire to avoid an accident or the product catching fire. Do not put the product in a location where it is exposed to direct sunlight, near heating devices, or in places with high temperatures, high humidity, or high concentrations of dust to avoid electric shock, fire, malfunction, etc.  
Keep away from a fire to avoid deformation or malfunction.  
Do not use chemicals such as benzine, thinner, electrical contact cleaner, etc. to avoid deformation or malfunction.