

**X**Performance

**X9BTMARBLE Series**

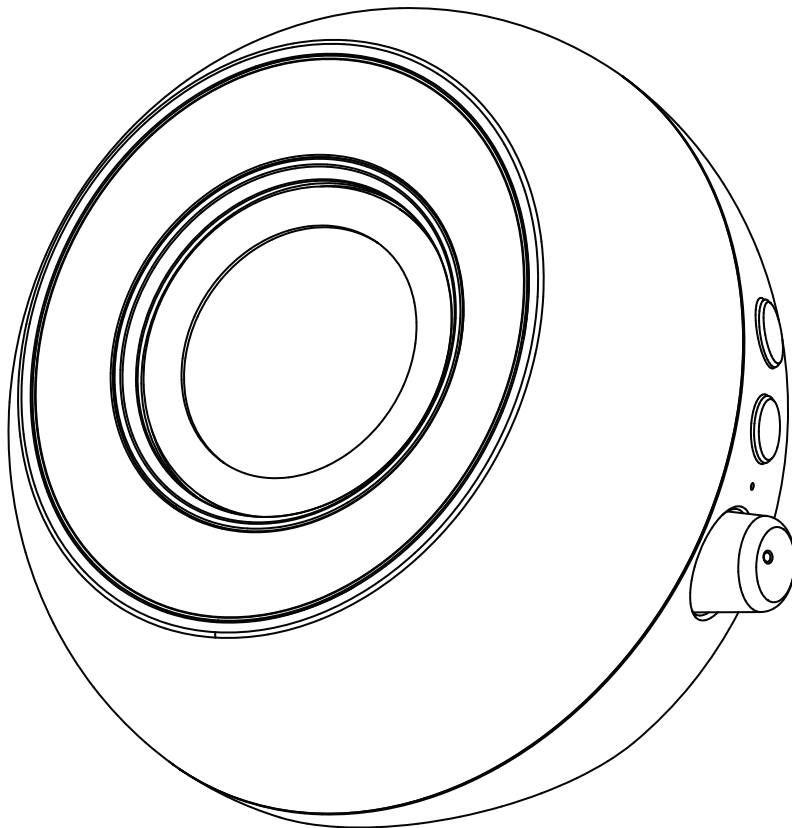

**Desktop Wired or Wireless BT Speaker**



Welcome to the X9 Performance family and thank you for purchasing the X9BTMARBLE.

Our mission is to deliver aesthetically pleasing, high-quality and affordable peripherals and accessories to satisfied customers. We do that by creating products that are both innovative and practical but most important easy-to-use.

If you have any questions, feedback, or just want to say hi, please reach out to us at [techsupport@X9Performance.com](mailto:techsupport@X9Performance.com).

With Love From Southern California,  
X9 Performance

# PACKAGE CONTENTS

- Speaker
- User's Guide

# SYSTEM REQUIREMENTS

- Any laptop or desktop with an available USB-A port.
- Any laptop, desktop, smartphone or tablet equipped with BT.
- USB-C to USB-A HUB (for laptops and desktops that are equipped with USB-C ports only).  
USB Power Output: 5V / 2A required.

## NOTE

*Using a lower-power USB output may result in sound skipping or unstable performance.*

# HARDWARE BASICS

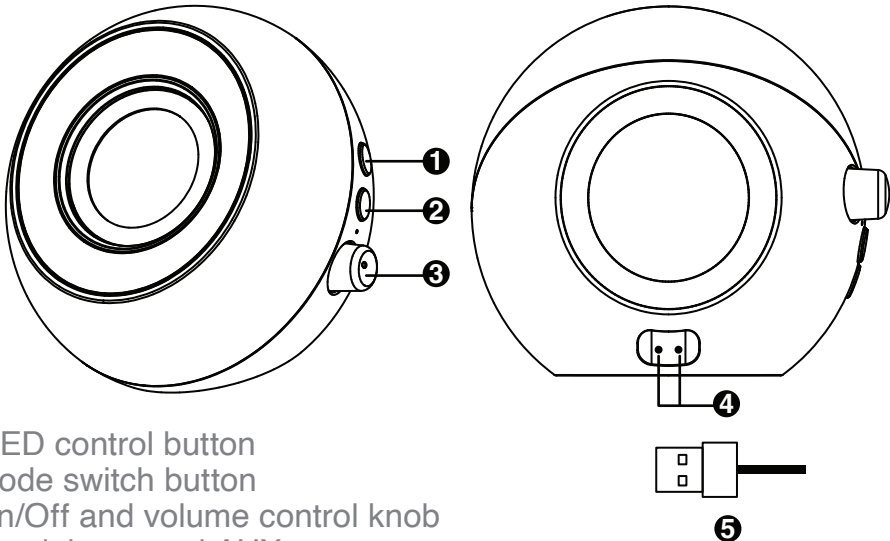

1. LED control button
2. Mode switch button
3. On/Off and volume control knob
4. Headphone and AUX port
5. USB-A plug

# INSTALLATION INSTRUCTIONS



Insert the speaker's USB-A cable into any available USB-A port on your desktop laptop, or wall adapter.

## **NOTE**

*You will need to purchase a USB-C to USB-A HUB if you are using a desktop or laptop that is equipped with only USB-C ports*

# TURNING THE SPEAKER ON/OFF AND VOLUME ADJUSTMENT

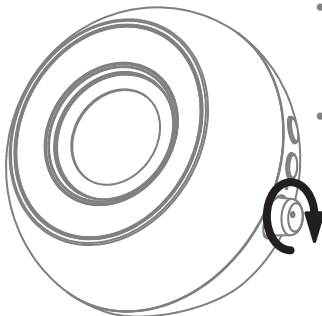

- To turn the speaker on simply turn the On/Off volume knob up (clockwise). You will hear a click when you turn the speaker on/off.
- To adjust the volume of the speaker, you can turn the knob clockwise (Volume up) or counter clockwise (Volume down). You can also adjust the volume up and down using the connected devices volume controls.

## SWITCHING BETWEEN PC & BT MODES

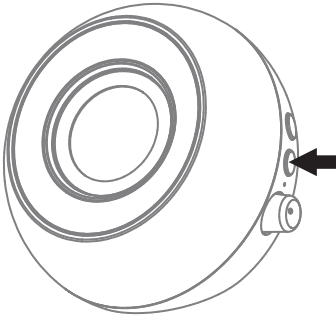

To change between PC mode (USB Wired) and BT mode

Press and hold the mode switch button until you hear a sound for the mode you want.

### Pairing The BT Speakers

1. Hold the mode switch button until you hear “BT Mode.”
2. Go to your device’s BT settings.
3. Select “X9BTMARBLE” to connect.

### Connecting to a Different BT Device

1. Press the mode switch button three times. You’ll hear a sound confirming the disconnection for the current device.
2. Once the previous device is disconnected, the speaker will automatically enter pairing mode.
3. Go to your device’s BT settings. select “X9BT-MARBLE” to connect.

By following these steps, you should be able to easily connect your speaker to a different device.

## CONTROLLING THE LED MODE

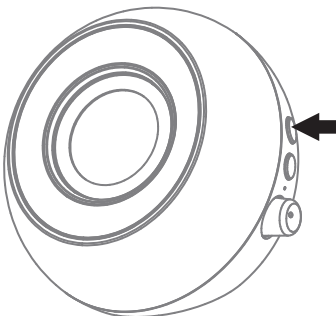

The speaker’s LED is defaulted to white. You can change or turn off the LED via the LED control button at any time.

- To turn off – Hold the LED control button for two seconds
- To turn on – Press the LED control button
- Change the LED color- Keep pressing the LED control button until you reach the desired option.

# SAFETY INSTRUCTIONS

Please read the following carefully. Incorrect use of this product may result in reduced performance, permanent damage and void your warranty.

- Keep this device away from liquid, humidity and moisture.
- Operate this device only within the specific temperature range of 0°C (32° F) to 5°C to 40°C(104° F)
- Please refrain from taking the device apart. Doing so will void your warranty.
- Do not dispose this product in the garbage. Take it to your local recycling center.

# SPECIFICATIONS

LED options	10
Connectivity Options	Wired USB-A & BT
Optional inputs	Headphone and AUX
Speaker Size	2.25"*2+2*passive radiators
Output Power (R.M.S)	4W*2
Frequency Response	110Hz-20KHz
Sensitivity	85dB
BT Version	V5.4
Power Input (USBA)	5V/2A (USB A)
Unit Size	W115*H123*D100mm
Weight	650g
interface	USB A/Earphone output/Aux in

## **Tech support**

Tech support hours are from 9:00 AM to 5:00 PM Monday through Friday (Pacific Standard Time).

Phone: (909) 230-6788

E-mail: techsupport@X9Performance.com

### **FCC STATEMENT**

*This device complies with part 15 of the FCC Rules. Operation is subject to the following two conditions: (1) This device may not cause harmful interference, and (2) this device must accept any interference received, including interference that may cause undesired operation.*

*Any Changes or modifications not expressly approved by the party responsible for compliance could void the user's authority to operate the equipment.*

**Note:** *This equipment has been tested and found to comply with the limits for a Class B digital device, pursuant to part 15 of the FCC Rules. These limits are designed to provide reasonable protection against harmful interference in a residential installation. This equipment generates uses and can radiate radio frequency energy and, if not installed and used in accordance with the instructions, may cause harmful interference to radio communications. However, there is no guarantee that interference will not occur in a particular installation. If this equipment does cause harmful interference to radio or television reception, which can be determined by turning the equipment off and on, the user is encouraged to try to correct the interference by one or more of the following measures: .*

- Reorient or relocate the receiving antenna.*
- Increase the separation between the equipment and receiver.*
- Connect the equipment into an outlet on a circuit different from that to which the receiver is connected.*
- Consult the dealer or an experienced radio/TV technician for help.*

*The device has been evaluated to meet general RF exposure requirement. The device can be used in portable exposure condition without restriction.*

## **Warranty**

*X9 Performance warrants that this product will be free from defects in title, materials and manufacturing workmanship for one year in North America from the date of the purchase. If the product is found to be defective then, as your sole remedy and as the manufacturer's only obligation, X9 Performance will repair or replace the product. This warranty is exclusive and is limited to the product that this user's guide came with. This warranty shall not apply to products that have been subjected to abuse, misuse, abnormal electrical or environmental conditions, or any condition other than what can be considered normal use. The liability of X9 Performance arising from this warranty and sale shall be limited to a refund of the purchase price. In no event shall X9 Performance be liable for costs of procurement of substitute products or services, or for any lost profits, or for any consequential, incidental, direct or indirect damages, however caused and on any theory of liability, arising from this warranty and sale. These limitations shall apply notwithstanding any failure of essential purpose of any limited remedy.*