

Dual Monitor Mount on 400 Post

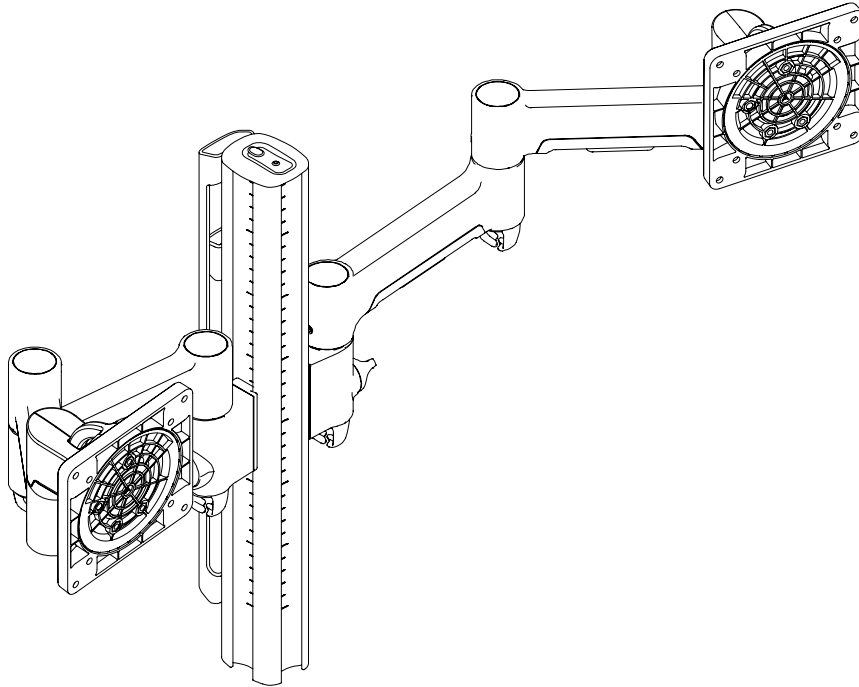

INDEX

Component Checklist	Page 2
AWM 400 Post with Guide Marks AWM-P40G	Installation Instructions Page 3
AWM 460 Arm AWM-A46T	Installation Instructions Page 4
Cable Management	Page 6

IMPORTANT INFORMATION

- ! Please ensure this product is installed as per these installation instructions.
- ! Do not remove or throw away the plastic sleeve on the arm link and channel clamp.
- ! The manufacturer accepts no responsibility for incorrect installation.
- ! This product is not suitable for outdoor use or mobile applications
- ! Do not over-tighten screws and adjustment points on product.
- ! Periodic adjustment to counterbalance and tilt tension may be required.
- ! VESA mounted accessories (such as mini PC brackets and mounts), offset VESA locations, and unevenly weighted monitors (relative to the center of the VESA mounting interface) exert additional leverage that can exceed the capacity of the mount even though the monitor weight may be within the stated range. Please contact Atdec if you would like further information.



REQUIRED TOOLS

- Phillips Head Screwdriver



CAPACITY



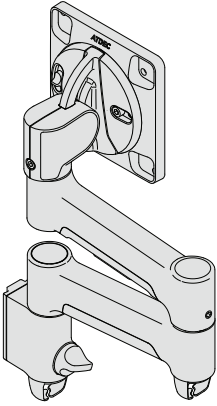
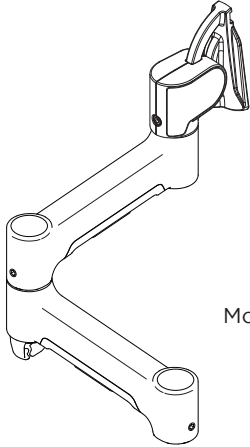
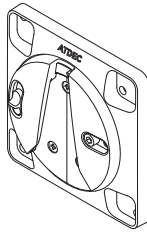
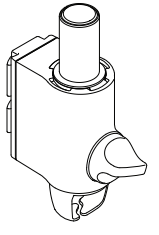

- Flat Monitors**
0 - 12kg (0 - 26.5lbs)
- Curved Monitors***
0 - 10kg (0 - 22lbs)

*Curved monitors with an overall depth up to 140mm (5.5").

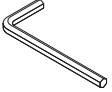
Monitor weight should be within the weight range of all modular elements that make up the complete monitor mounting solution.

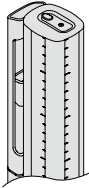
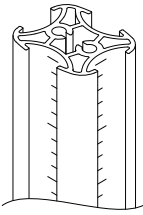
COMPONENT CHECKLIST

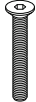
<p>AWM 460 Arm AWM-A46T Product Quantity 2</p>		 <p>A Monitor Arm (x1)</p>	 <p>B VESA Head (x1)</p>	 <p>C Channel Clamp (x1)</p>	
			 <p>D Screw M4x10mm (x4)</p>	 <p>E Security Screw (x1)</p>	 <p>F 4mm Hex Key (x1)</p>

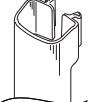
<p>400 Post AWM-P40G Product Quantity 1</p>		 <p>A Post (x1)</p>	 <p>B Post Cap (x1)</p>	 <p>C Screw M8 (x2)</p>	 <p>D Cable Cover Cap (x4)</p>	 <p>E Cable Cover (x2)</p>
-------------------------------------------------------------------	------------------------------------------------------------------------------------	----------------------------------------------------------------------------------------------------------------------	-----------------------------------------------------------------------------------------------------------------------------	--------------------------------------------------------------------------------------------------------------------------------	--------------------------------------------------------------------------------------------------------------------------------------	-----------------------------------------------------------------------------------------------------------------------------------

DESK FIXING OPTIONS

Below are the fixing options available for this solution. Fixing installation guides are supplied with the product or can be accessed through Atdec's website, along with detailed product specifications.

NOTE: Chosen desk fixing must be added to this solution code when ordering.

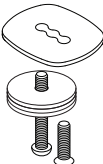
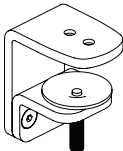
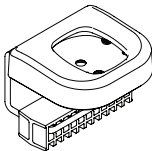
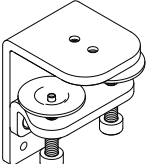
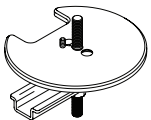
<p>BOLT THROUGH AWM-FB</p>	<p>F CLAMP AWM-FF</p>	<p>C CLAMP AWM-FC</p>	<p>HEAVY DUTY F CLAMP AWM-FH</p>	<p>GROMMET CLAMP AC-GC</p>
				

1. Attach post to fixing

1.1 Follow the installation guide provided with your fixing to attach it to the post and fit it to the worksurface.

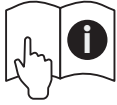

BOLT THROUGH
AWM-FB

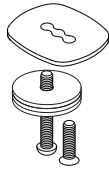

F CLAMP
AWM-FF

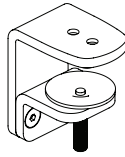

C CLAMP
AWM-FC

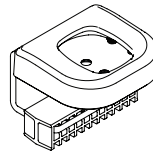

HEAVY DUTY F CLAMP
AWM-FH

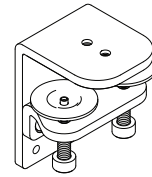

GROMMET CLAMP
AC-GC

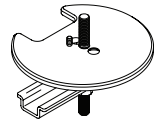

2. Attach channel clamp to post

2.1 Ensure knob is undone.

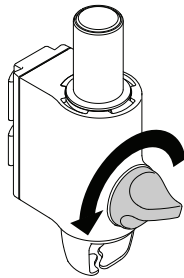

2.2 Slide channel clamp into channel.

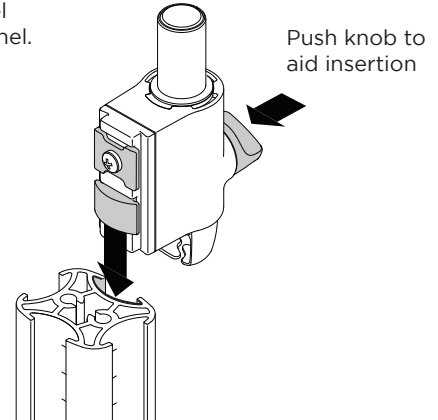

2.3 Hold clamp in desired position on channel and turn knob to lock in place.

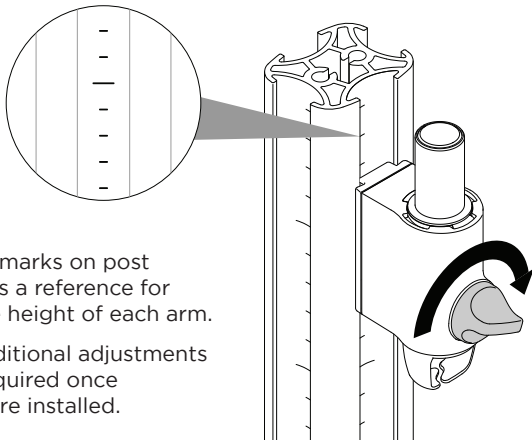

Use guide marks on post channels as a reference for setting the height of each arm.

NOTE: Additional adjustments may be required once monitors are installed.

NOTE: Do not mount monitor arm on rear channel post when using the following desk clamps:

AWM-FF

AWM-FC

AWM-FH

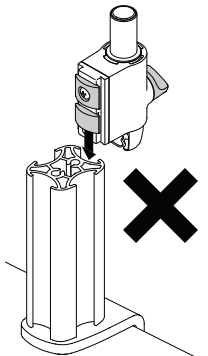
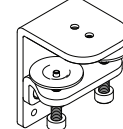
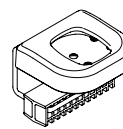
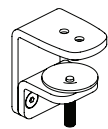

3. (OPTIONAL) Set arm rotation to 180°

NOTE: Rotation is set to 360° by default.

3.1 Remove plastic sleeve from channel clamp.

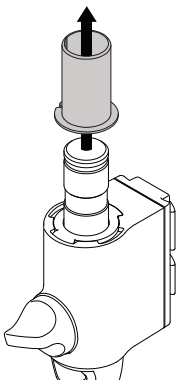

3.2 Remove rotation ring.

2. Lift

1. Press

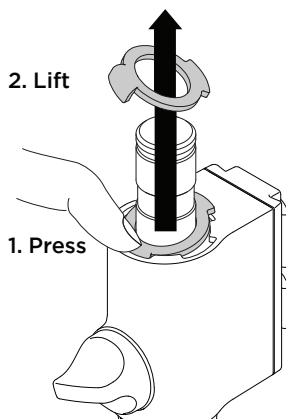

3.3 Place rotation ring in desired position and **replace** plastic sleeve.

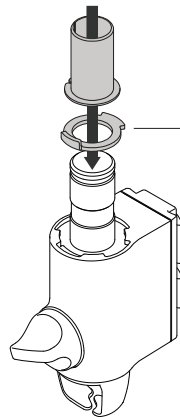

Default
Position

360°

OR

180°

Flipped
Position

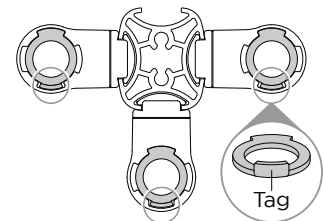

NOTE: Rotation ring placement depends on the position of the clamp on the post. The tag on the ring should always face toward the user.

4. Attach arm onto channel clamp

4.1 Push lower link onto shaft.

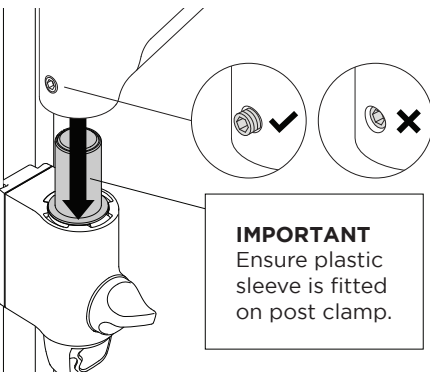

IMPORTANT
Ensure plastic sleeve is fitted on post clamp.

4.2 Ensure arm is fully pushed onto shaft.

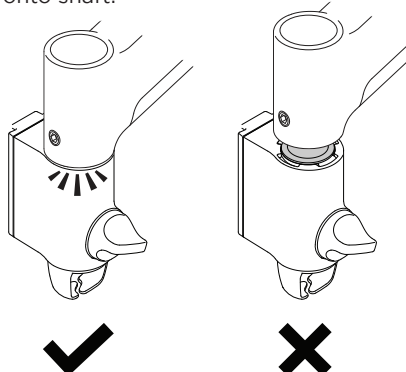

4.3 Tighten joint screw.

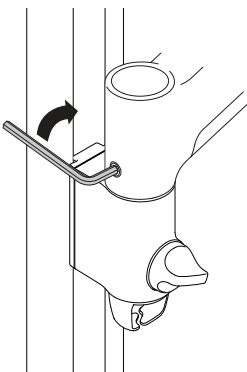

NOTE:
Check the arm rotation is smooth after tightening.

5. Attach VESA head to monitor

5.1 Check VESA mounting compatibility of monitor.

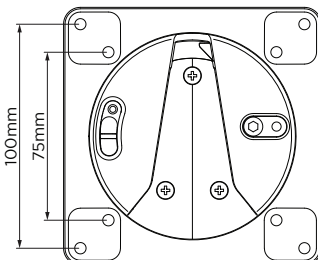

NOTE: Ensure screw length suits the monitor VESA mounting holes.

OK

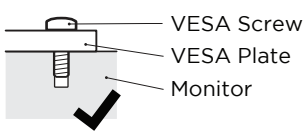

Too long

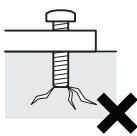

Too short



5.2 Attach VESA head onto monitor with provided screws. (Alternatively, use fasteners specified by the monitor manufacturer.)

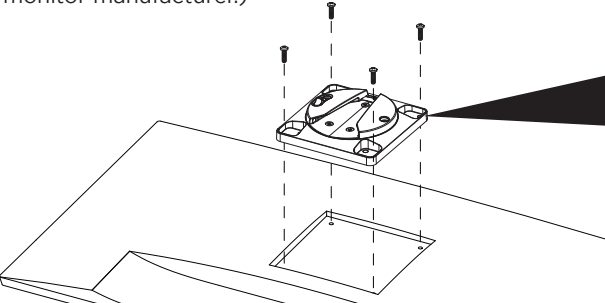

NOTE: Recessed 75x75 VESA interfaces will require a Spacer Kit (sold separately)

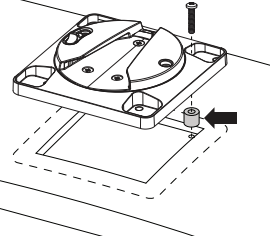

TIP! To allow monitor to be rotated upside down, mount VESA head in the alternate orientation shown.

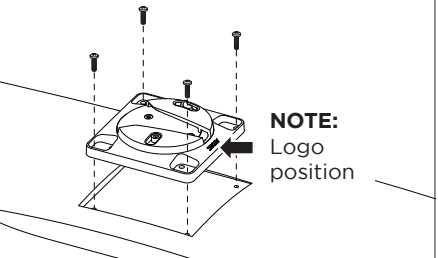

NOTE: Logo position

6. Attach monitor to arm

6.1 Fit monitor onto arm.

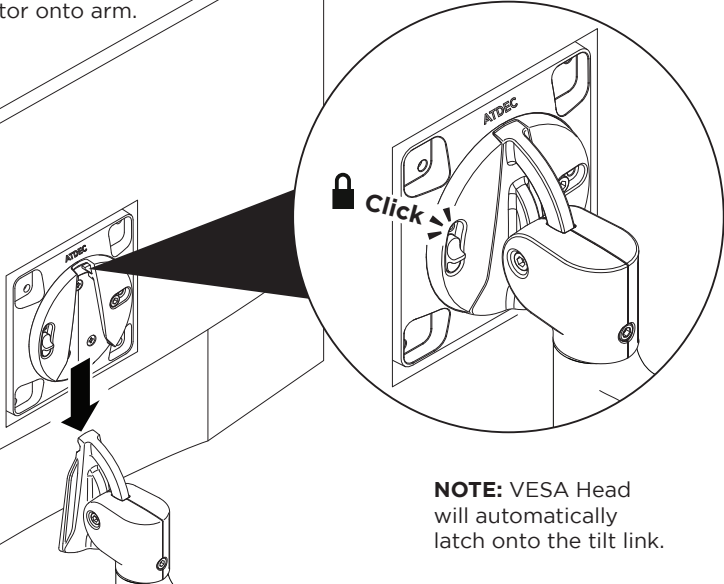

NOTE: VESA Head will automatically latch onto the tilt link.

6.2 OPTIONAL SECURITY SCREW
If desired, once monitor is attached to the arm, install the security screw which disables the release switch.

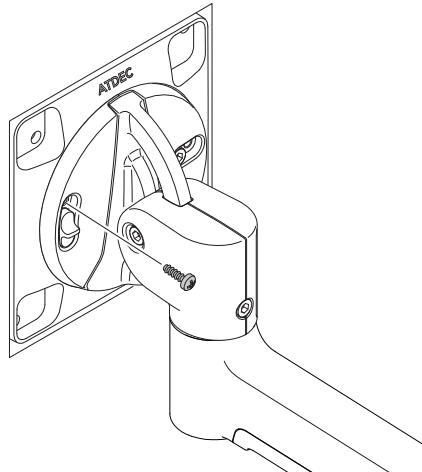

7. (OPTIONAL) Adjust tilt tension

7.1 If required, adjust the tilt tension using the 4mm hex key.



DROOPS FORWARD

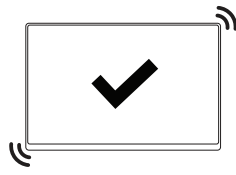

HOLDS POSITION

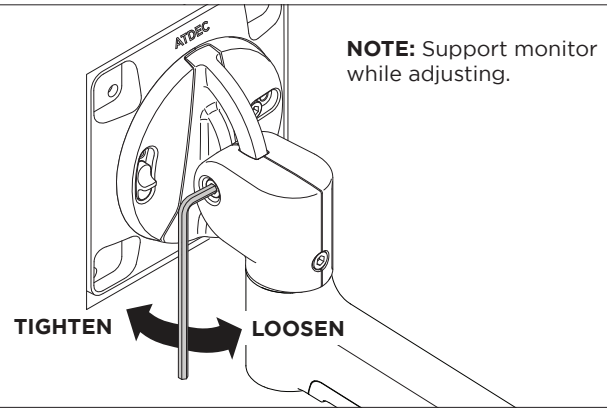

8. (OPTIONAL) Adjust rotation tension

8.1 Adjust the rotation tension using 4mm hex key. Adjustment may only be required for ultrawide monitors.

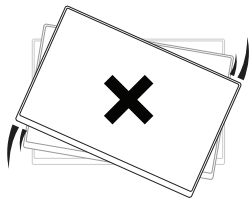

DRIFTS

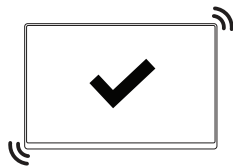

HOLDS POSITION

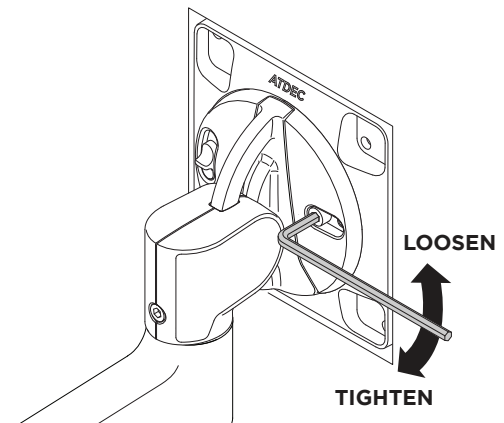

9. (OPTIONAL) Adjust joint tension

9.1 Use the 4mm hex key to adjust the tension of the pivot joints on the arm.

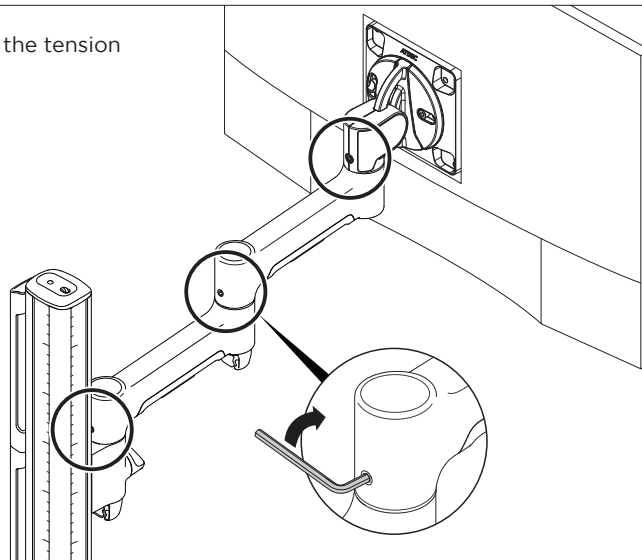

DO NOT OVERTIGHTEN
Increasing tension only stiffens movement and cannot lock off arm movement.

10. Removing monitor

10.1 Slide release switch up and click into unlocked position, then lift monitor away from the arm.

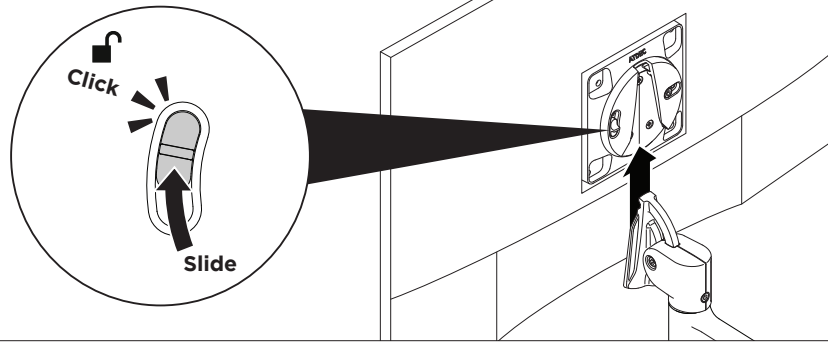

11. Cable management

11.1 Plug cables into the monitor and route the cables down the arm using the cable hooks and clips.

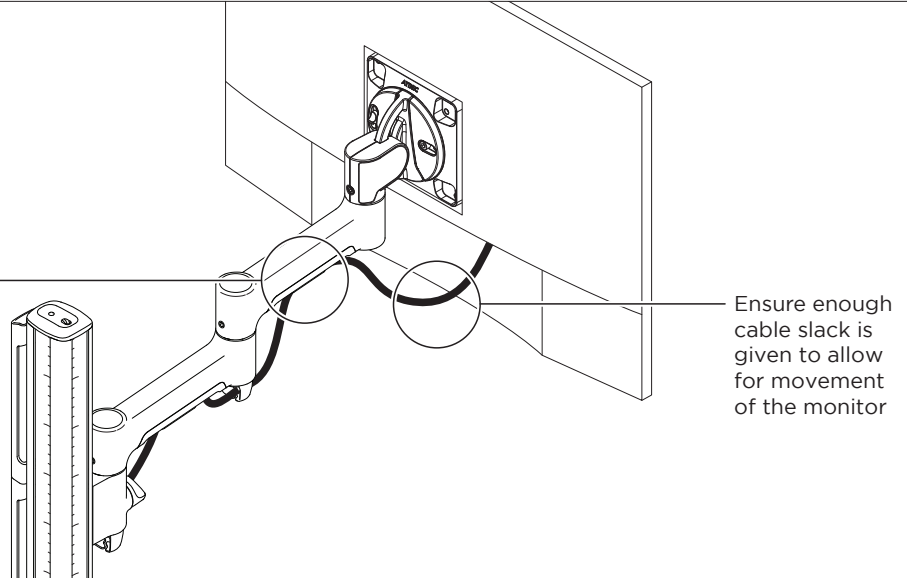
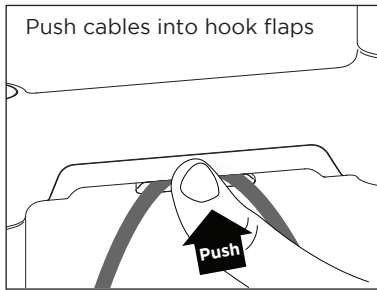

11.2 To reposition the cable cover, pull it straight up and out of the post and insert it into any of the available channels.

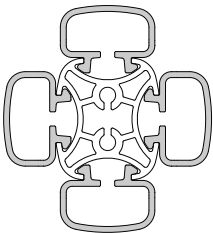

Optional cable cover positions

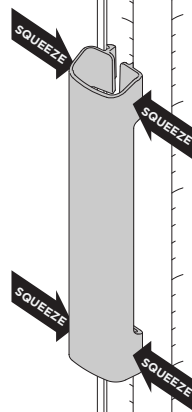

11.3 Fit post cap onto the top of the post.

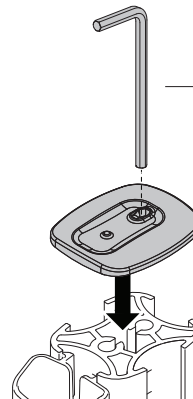

Hex Key
(supplied with
AWM Post)

Post Cap
(Hex Key can
be stored in
the Post Cap)

Post

11.4 Load cables into cable clip.

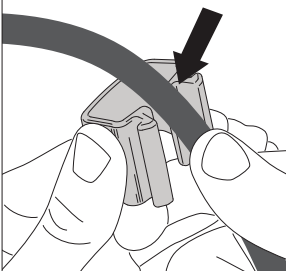

11.5 Insert one side of the cable clip into the channel on the post assembly, then push in the other side.

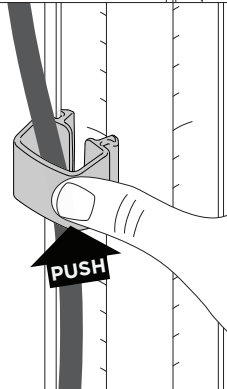

11.6 Load cables into cable cover.

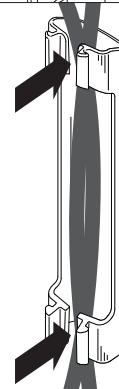

11.7 Clip the cable cover onto any of the four post channels.

