

DP8K-EDID-EMLTR

DisplayPort 1.4 EDID Emulator



The DisplayPort 1.4 EDID Emulator stores and reproduces EDID information for a DisplayPort display, and resolves video communication problems that occur between a DisplayPort video source and display. It is designed for systems that require EDID signals to be continuously provided without interruption, and ensures that the EDID signal is not lost when using AV/KVM extenders and splitters. Additionally, the emulator can be used in place of a monitor to keep the graphics card of a PC or server awake for remote access over IP.

- Emulates a DisplayPort display (sink device) by providing Hot Plug Detect and EDID to the DisplayPort source device.
- Supports Ultra-HD 8K resolutions to 7680x4320@30Hz 4:4:4, Ultrawide 5K resolutions to 5120x2160@60Hz, Ultra-HD 4Kx2K resolutions to 3840x2160@60Hz 4:4:4, 3440x1440 (UWQHD), 2560x1600 (WQXGA), 2560x1440 (WQHD), and HDTV resolutions to 1080p.
- DisplayPort features supported:
 - DisplayPort 1.4
 - Multi-Stream Transport (MST)
 - Up to 36-bit Deep Color
 - LPCM
 - YCbCr 4:4:4, YCbCr 4:2:2, and RGB
 - Bandwidth up to 32.4 Gbps
- HDCP 2.2 compliant.
- Supports Learning and Emulation modes.
 - Learning mode: store a display's EDID for later use.
 - Emulation mode: provides EDID to the DisplayPort source device from the emulator's internal memory.
 - **Supports headless operation – no monitor attached to source.**
 - Ideal for remote desktop access to a headless computer, virtual desktop on VR headsets, and for use with GPGPU tasks such as cryptocurrency mining.
- Pre-programmed with many standard resolutions with native set to 1080p.
 - Use learning mode to program other resolutions.
- LED indicator provides signal status information.
- Compact design for easy installation and operation.
- No power supply – powered by video source.
- Use for resolving signal handshaking problems between a source and a display.

Not recommended for use in conjunction with KVM or video-only switches.

Reason: When the input channel is deselected, the emulator will be powered off. The host computer connected to that input channel via DP emulator will recognize the emulated monitor as disconnected.

NTI's [DisplayPort Hotplug Maintainer](#) emulates a DisplayPort display (sink device) by providing Hot Plug Detect (HPD) signal to the DisplayPort source device. When used with a KVM/video switch, the DP-HP-MNTR-SRC eliminates the need to reconfigure monitor settings when switching between computers.

Features

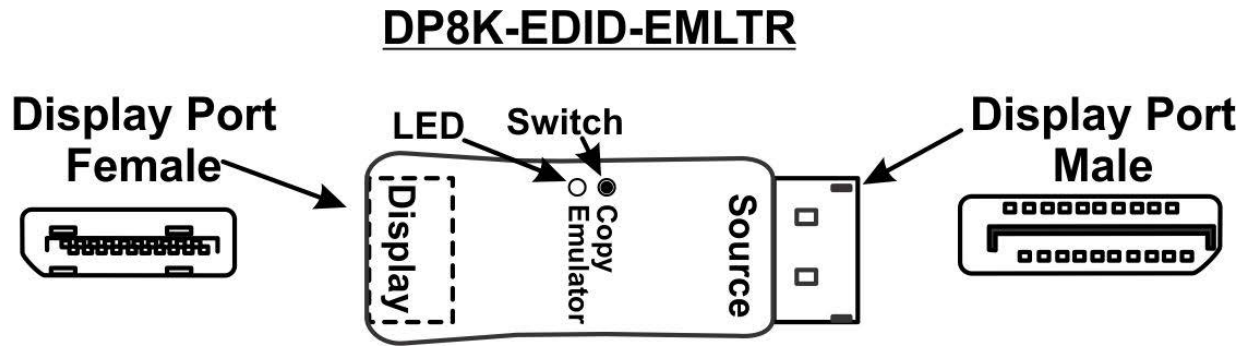

Learning Mode

1. Connect a DisplayPort cable between the emulator (at "Display") and the display device and power ON the display device.

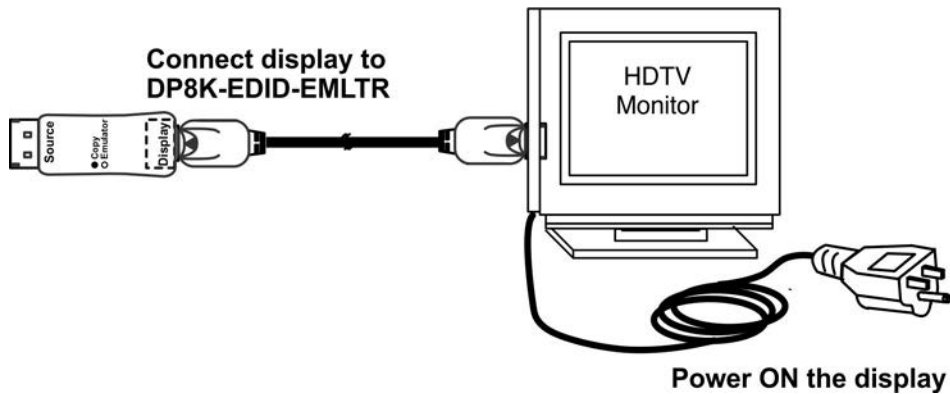

2. Plug the DisplayPort male ("Source") connector of the DP8K-EDID-EMLTR emulator into the video source. Power ON the video source (if not already ON).

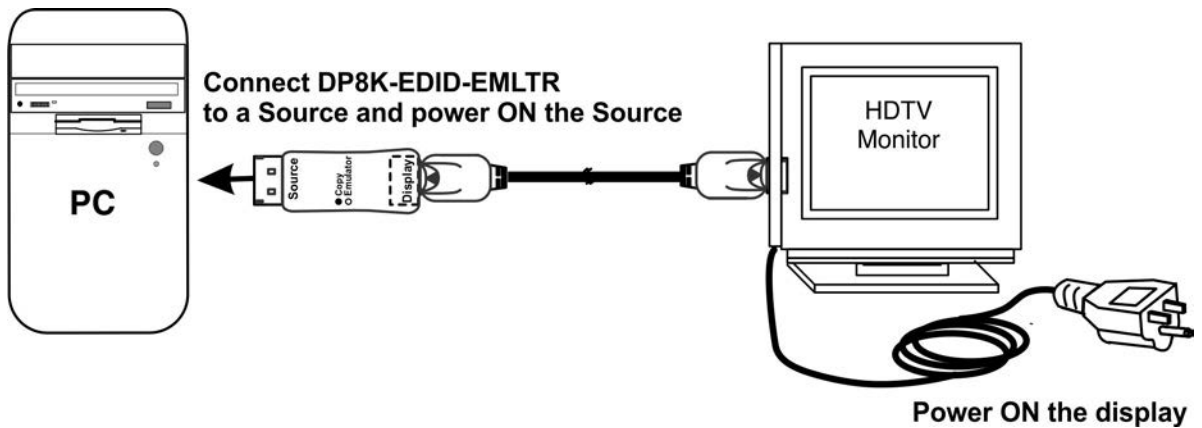

3. Press "Copy" button on the DP8K-EIDI-EMLTR. The Blue EDID LED will illuminate solid when the EDID has been learned.

Note: While teaching the emulator, the monitor may or may not display video. As long as the video shows up after step 3, the teaching step is successful.

Note: If the emulator needs to be reset back to its default EDID resolution of 1920x1080p, with the DP8K-EDID-EMLTR plugged into a source and with no monitor connected, press "Copy".

The EDID table copied during the Learning Mode will be available to provide the desired resolution to your monitor(s). **Note: Make sure your monitor is capable of displaying the selected resolution.**

Connect to Your Application

Once the emulator has learned the EDID table and is in Emulation Mode, the emulator can be placed in its ultimate configuration, following these steps, in order.

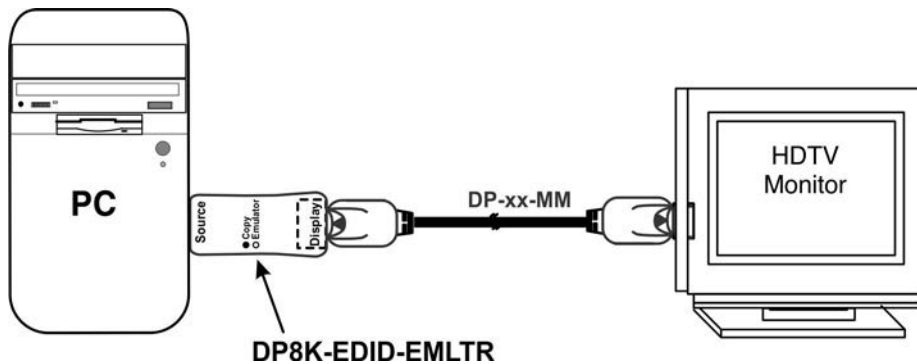

1. Unplug the emulator from the video source.

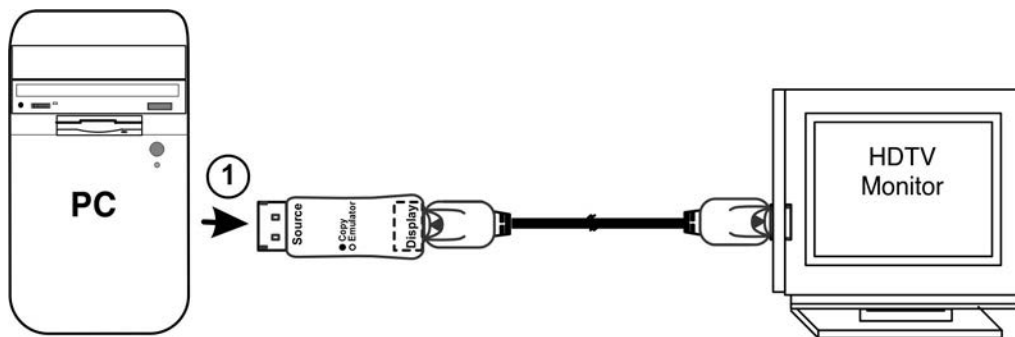

2. Unplug the cable from the "Display" port going to the monitor.

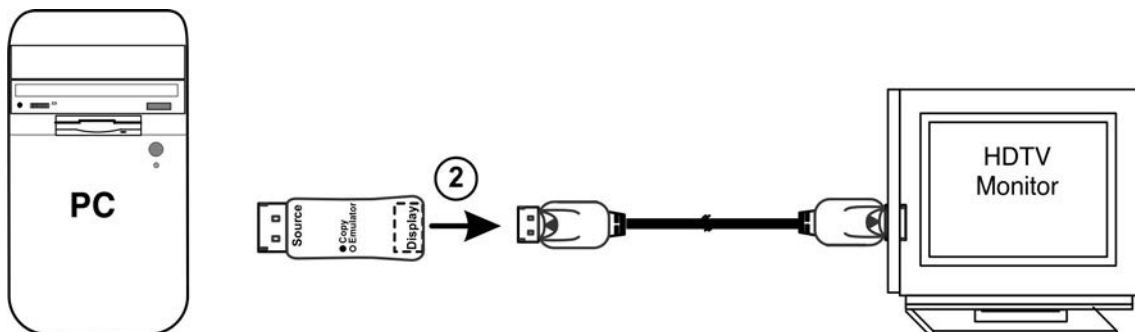

3. Make your connections from the DisplayPort cable to the display, splitter or extender and power the splitter or extender and associated display(s) ON.

4. Plug the DisplayPort cable back into the "Display" port on the emulator.

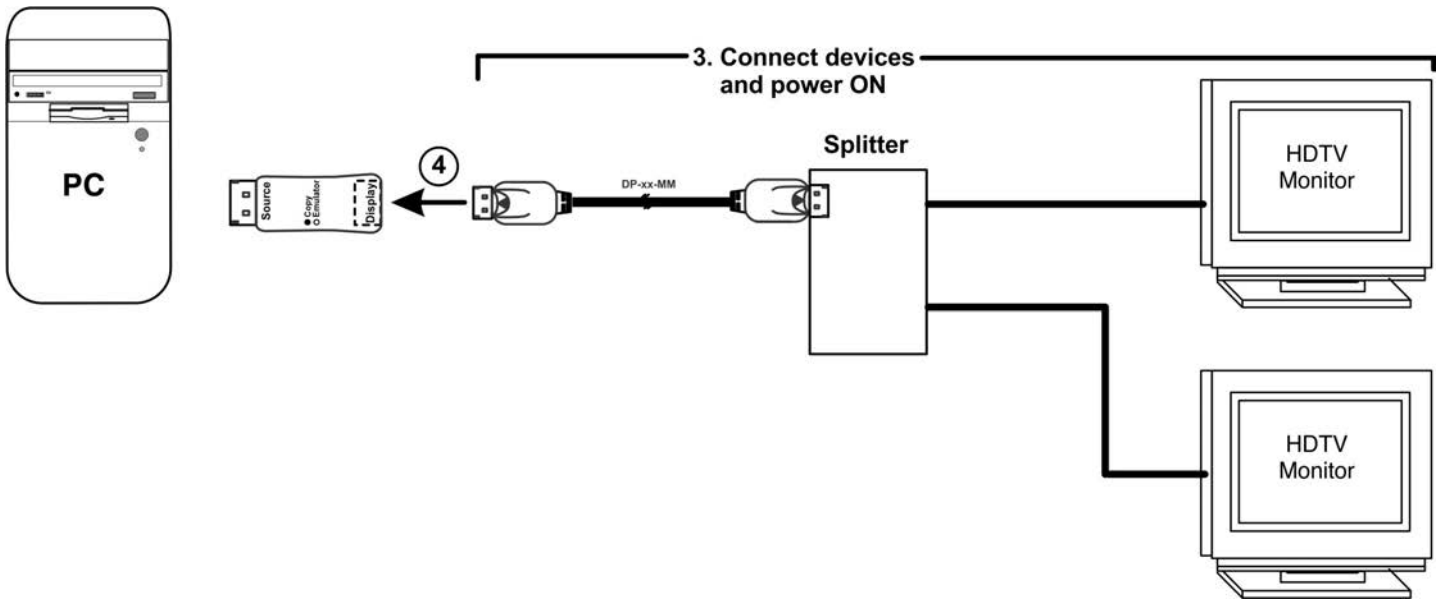

5. Plug the emulator back into the video source.

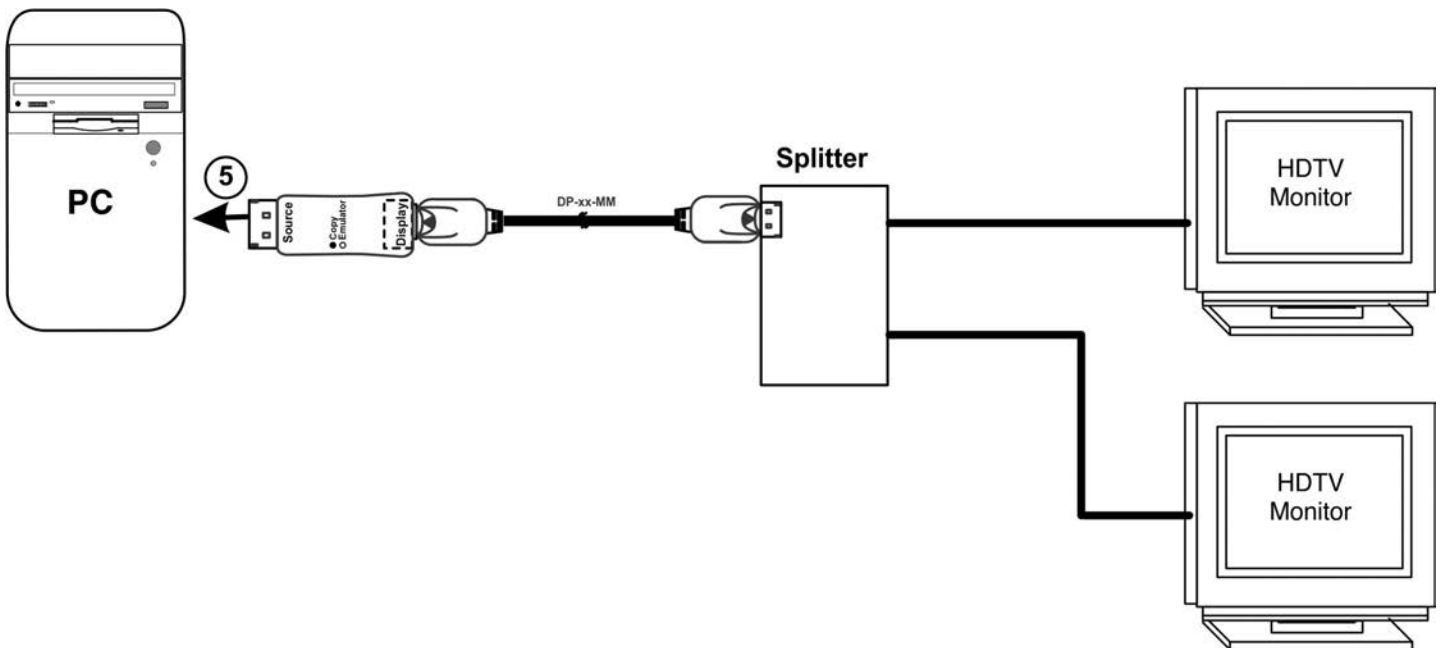

Specifications

Video Format	DP 1.4
Max. Resolution	7680x4320@30Hz
Default Resolution	1920x1080p@60Hz
Color Depth	RGB/YCC 4:4:4 / YCC 4:2:2: 10-bit Up to 36-bit deep color
Support pass-through	No
Support headless (no monitor actually attached)	Yes
HDCP Support	HDCP 2.2
Audio Format	LPCM
Power Supply	By video source
Operating Temperature	32 to 122°F (0 to 50°C)
Storage Temperature	-4 to 158°F (-20 to 70°C)
Operating and Storage Relative Humidity	5 to 85% non-condensing RH
Dimension WxDxH	0.99 x 2.50 x 0.47 in (25x64x12 mm)
Compliance	CE, FCC, RoHS, TAA

EDID mode resolutions

Resolution	Resolution
640x480p @60Hz	1920x1080p @60Hz *
720x480p @60Hz	2560x1440p @60Hz
800x600p @60Hz	2560x1600p @60Hz
1024x768p @60Hz	3440x1440p @60Hz
1280x720p @60Hz	3440x1440p @75Hz
1280x800p @60Hz	3440x1440p @100Hz
1280x960p @60Hz	3840x2160p @30Hz
1280x1024p @60Hz	3840x2160p @60Hz
1440x900p @60Hz	7680x4320 @30Hz
1680x1050p @60Hz	

*1920x1080p @60Hz is the native resolution in EDID mode

Audio EDID

LPCM 2-channel, 16/20/24 bit depths at 32/44/48/88/96/176/192 kHz