

## Operating Instructions

LCD View Finder

Model No. **AK-HVF75G**

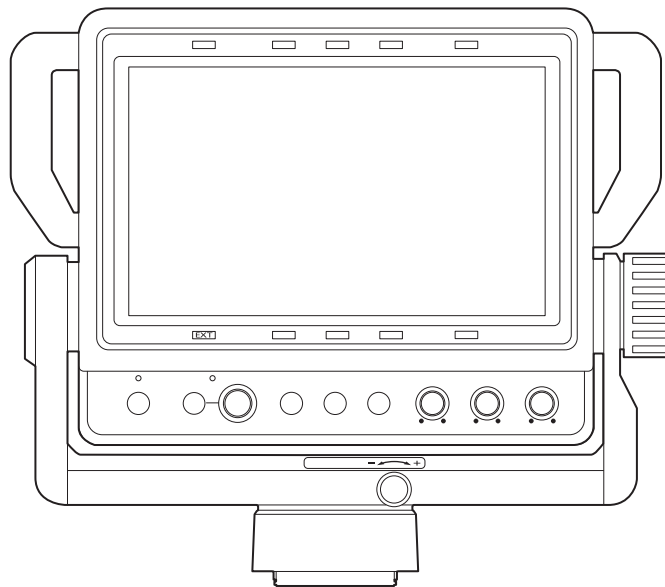

### ENGLISH

Before using this product, be sure to read "Read this first!" (pages 3 to 6).

### DEUTSCH

Bitte lesen Sie sorgfältig die „Bitte lesen Sie zuerst diesen Hinweis!“ vor der Nutzung dieses Produkts. (Seiten 7 bis 8).

Weitere Informationen finden Sie auf der Panasonic-Webseite (<https://pro-av.panasonic.net/manual/en/index.html>) und in der Bedienungsanleitung.

### FRANÇAIS

Avant d'utiliser cet appareil, assurez-vous de lire la section « Lire ces informations en premier ! » (pages 9 à 11).

Pour de plus amples informations, visiter le site Web de Panasonic (<https://pro-av.panasonic.net/manual/en/index.html>) et consulter le mode d'emploi.

### ITALIANO

Prima di utilizzare il prodotto, assicurarsi di leggere "Leggere prima quanto segue!" (pagine 12 a 13).

Per maggiori informazioni, per favore visitare il sito web Panasonic (<https://pro-av.panasonic.net/manual/en/index.html>), e fare riferimento alle istruzioni per l'uso.

### ESPAÑOL

Antes de usar este producto, asegúrese de leer "Lea esto primero" (páginas 14 a 16).

Si desea obtener más información, visite el sitio web de Panasonic (<https://pro-av.panasonic.net/manual/en/index.html>) y consulte las instrucciones de funcionamiento.

Before operating this product, please read the instructions carefully and save this manual for future use.



|                    |   |
|--------------------|---|
| <b>Български</b>   | Посетете следния уебсайт относно информация за безопасността и важни уведомления за продукта.   |
| <b>Hrvatski</b>    | Za sigurnosne informacije i važne obavijesti o proizvodu posjetite sljedeću internetsku stranicu.   |
| <b>Čeština</b>     | Na následujícím webu najdete bezpečnostní informace a důležité poznámky k tomuto produktu.  |
| <b>Dansk</b>       | Besøg følgende webside for sikkerhedsinformation og vigtige bemærkninger vedrørende produktet.  |
| <b>Nederlands</b>  | Ga naar de volgende website voor veiligheidsinformatie en belangrijke meldingen over het product.   |
| <b>Eesti</b>       | Toodet puudutava ohutusteabe ja oluliste märkuste saamiseks külastage järgmist veebilehte.  |
| <b>Suomi</b>       | Käy seuraavalla verkkosivulla saadaksesi turvallisuustietoja ja tärkeitä tietoja liittyen laitteeseen.                                      |
| <b>Ελληνικά</b>    | Για πληροφορίες σχετικά με θέματα ασφάλειας και σημαντικές ειδοποιήσεις που αφορούν το προϊόν σας, επισκεφτείτε τον ιστότοπο που ακολουθεί. |
| <b>Magyar</b>      | A termékkel kapcsolatos biztonsági információkért és fontos értesítésekért látogasson el az alábbi weboldalra.                              |
| <b>Latviešu</b>    | Lai iegūtu informāciju par drošību un skatītu svarīgus paziņojumus par šo produktu, apmeklējiet tālāk norādīto tīmekļa vietni.              |
| <b>Lietuvių</b>    | Jei reikia saugos informacijos ir svarbių pranešimų apie gaminį, apsilankykite toliau nurodytoje svetainėje.                                |
| <b>Polski</b>      | Informacje o bezpieczeństwie i ważne informacje o produkcie znajdują się w poniższej witrynie internetowej.                                 |
| <b>Português</b>   | Consulte o seguinte website para as informações de segurança e importantes notificações sobre o produto.                                    |
| <b>Română</b>      | Vizitați următoarea pagină web pentru informații de securitate și notificări importante cu privire la produs.                               |
| <b>Slovensky</b>   | Pre bezpečnostné informácie a dôležité oznámenia súvisiace s produktom navštívte túto webovú stránku.                                       |
| <b>Slovenščina</b> | Za varnostne informacije in pomembna obvestila v zvezi z izdelkom obiščite naslednje spletno mesto.   |
| <b>Svenska</b>     | Besök följande webbplats för säkerhetsinformation och viktiga meddelanden om produkten.   |

<https://pro-av.panasonic.net/manual/en/index.html>

## Read this first!

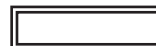

indicates safety information.

### WARNING:

- To reduce the risk of fire, do not expose this equipment to rain or moisture.
- To reduce the risk of fire, keep this equipment away from all liquids. Use and store only in locations which are not exposed to the risk of dripping or splashing liquids, and do not place any liquid containers on top of the equipment.

### WARNING:

Always keep accessories (camera number sheet) out of the reach of babies and small children.

### WARNING:

This equipment is compliant with Class A of CISPR 32.  
In a residential environment this equipment may cause radio interference.

### CAUTION:

Do not remove panel covers by unscrewing. No user serviceable parts inside. Refer servicing to qualified service personnel.

### CAUTION:

To reduce the risk of fire and annoying interference, use the recommended accessories only.

### CAUTION:

In order to maintain adequate ventilation, do not install or place this unit in a bookcase, built-in cabinet or any other confined space. To prevent risk of fire hazard due to overheating, ensure that curtains and any other materials do not obstruct the ventilation.

## FCC Notice

### Supplier's Declaration of Conformity

Trade Name: Panasonic  
 Model Number: AK-HVF75G  
 Responsible Party: Panasonic Corporation of North America  
 Two Riverfront Plaza Newark NJ07102  
 Support contact: 1-800-524-1448

This device complies with Part 15 of the FCC Rules. Operation is subject to the following two conditions: (1) This device may not cause harmful interference, and (2) this device must accept any interference received, including interference that may cause undesired operation.

### FCC Warning:

To assure continued FCC emission limit compliance, follow the attached installation instructions and the user must use only shielded interface cables when connecting to host computer or peripheral devices. Also, any unauthorized changes or modifications to this equipment could void the user's authority to operate this device.

### FCC Caution:

This equipment has been tested and found to comply with the limits for a class A digital device, pursuant to Part 15 of the FCC Rules. These limits are designed to provide reasonable protection against harmful interference when the equipment is operated in a commercial environment. This equipment generates, uses, and can radiate radio frequency energy and, if not installed and used in accordance with the instruction manual, may cause harmful interference to radio communications. Operation of this equipment in a residential area is likely to cause harmful interference in which case the user will be required to correct the interference at his own expense.

### NOTIFICATION (Canada)

CAN ICES-003(A)/NMB-003(A)

# IMPORTANT SAFETY INSTRUCTIONS

- 1) Read these instructions.
- 2) Keep these instructions.
- 3) Heed all warnings.
- 4) Follow all instructions.
- 5) Do not use this apparatus near water.
- 6) Clean only with dry cloth.
- 7) Do not block any ventilation openings. Install in accordance with the manufacturer's instructions.
- 8) Do not install near any heat sources such as radiators, heat registers, stoves, or other apparatus (including amplifiers) that produce heat.
- 9) Do not defeat the safety purpose of the polarized or grounding-type plug. A polarized plug has two blades with one wider than the other. A grounding-type plug has two blades and a third grounding prong. The wide blade or the third prong are provided for your safety. If the provided plug does not fit into your outlet, consult an electrician for replacement of the obsolete outlet.
- 10) Protect the power cord from being walked on or pinched particularly at plugs, convenience receptacles, and the point where they exit from the apparatus.
- 11) Only use attachments/accessories specified by the manufacturer.
- 12) Use only with the cart, stand, tripod, bracket, or table specified by the manufacturer, or sold with the apparatus. When a cart is used, use caution when moving the cart/apparatus combination to avoid injury from tip-over.
- 13) Unplug this apparatus during lightning storms or when unused for long periods of time.
- 14) Refer all servicing to qualified service personnel. Servicing is required when the apparatus has been damaged in any way, such as power-supply cord or plug is damaged, liquid has been spilled or objects have fallen into the apparatus, the apparatus has been exposed to rain or moisture, does not operate normally, or has been dropped.



## EMC NOTICE FOR THE PURCHASER/USER OF THE APPARATUS

### 1. Pre-requisite conditions to achieving compliance with the above standards

#### <1> Peripheral equipment to be connected to the apparatus and special connecting cables

- The purchaser/user is urged to use only equipment which has been recommended by us as peripheral equipment to be connected to the apparatus.
- The purchaser/user is urged to use only the connecting cables described below.

#### <2> For the connecting cables, use shielded cables which suit the intended purpose of the apparatus.

- Video signal connecting cables  
Use double-shielded coaxial cables, which are designed for 75-ohm type high-frequency applications, for SDI (Serial Digital Interface).  
Coaxial cables, which are designed for 75-ohm type high-frequency applications, are recommended for analog video signals.
- Audio signal connecting cables  
If your apparatus supports AES/EBU serial digital audio signals, use cables designed for AES/EBU.  
Use shielded cables, which provide quality performance for high-frequency transmission applications, for analog audio signals.
- Other connecting cables  
Use shielded cables, which provide quality performance for high-frequency applications, such as connecting cables for IEEE1394 or USB.
- When connecting to the HDMI signal terminal, use multilayer shielded cables, which provide quality performance for high-frequency applications.
- When connecting to the DVI signal terminal, use a cable with a ferrite core.
- If your apparatus is supplied with ferrite core(s), they must be attached on cable(s) following instructions in this manual.

### 2. Performance level

The performance level of the apparatus is equivalent to or better than the performance level required by these standards.

However, the apparatus may be adversely affected by interference if it is being used in an EMC environment, such as an area where strong electromagnetic fields are generated (by the presence of signal transmission towers, cellular phones, etc.). In order to minimize the adverse effects of the interference on the apparatus in cases like this, it is recommended that the following steps be taken with the apparatus being affected and with its operating environment:

1. Place the apparatus at a distance from the source of the interference.
2. Change the direction of the apparatus.
3. Change the connection method used for the apparatus.
4. Connect the apparatus to another power outlet where the power is not shared by any other appliances.

#### Manufactured by:

Panasonic Entertainment & Communication Co., Ltd.  
1-10-12, Yagumo-higashi-machi, Moriguchi City, Osaka, Japan

#### Importer:

Panasonic Connect Europe GmbH  
Hagenauer Strasse 43, 65203 Wiesbaden, Germany

#### Authorized Representative in EU:

Panasonic Connect Europe GmbH  
Panasonic Testing Centre  
Winsbergring 15, 22525 Hamburg, Germany

#### Importer for UK:

Panasonic Connect UK,  
a branch of Panasonic Connect Europe GmbH,  
Maxis 2, Western Road, Bracknell, Berkshire, RG12 1RT



|   |   |
|---|---|
|  | <p><b>Disposal of Old Equipment</b><br/> <b>Only for European Union and countries with recycling systems</b></p> <p>This symbol on the products, packaging, and/or accompanying documents means that used electrical and electronic products must not be mixed with general household waste.</p> <p>For proper treatment, recovery and recycling of old products, please take them to applicable collection points in accordance with your national legislation.</p> <p>By disposing of them correctly, you will help to save valuable resources and prevent any potential negative effects on human health and the environment.</p> <p>For more information about collection and recycling, please contact your local authority, dealer or supplier.</p> <p>Penalties may be applicable for incorrect disposal of this waste, in accordance with national legislation.</p> |
|---|---|

AEEE Yönetmeliğine Uygundur.  
 AEEE Complies with Directive of Turkey.

### ІНФОРМАЦІЯ ПРО ПІДТВЕРДЖЕННЯ ВІДПОВІДНОСТІ ПРОДУКТУ

|                    |   |   |
|--------------------|---|---|
| Виробник:          | Panasonic Entertainment & Communication Co., Ltd. | Панасонік Ентертейнмент енд Коммюнікаейшн Ко., Лтд. |
| Адреса виробника:  | Moriguchi City, Osaka, Japan                      | Моріґучі Осака Японія                               |
| Країна походження: | Japan   | Японія  |

|                                     |  |
|-------------------------------------|--|
| Уповноважений Представник:          | ТОВ "ПАНАСОНІК УКРАЇНА ЛТД"                          |
| Адреса Уповноваженого Представника: | вул. Васильківська, буд. 30, м. Київ, 03022, Україна |

**Примітки:**

|                      |         |
|----------------------|---------|
| Термін служби виробу | 7 років |
|----------------------|---------|

Дату виготовлення можна визначити за комбінацією букв і цифр серійного номера, що розташований на маркувальній таблиці виробу.

**Приклад:**

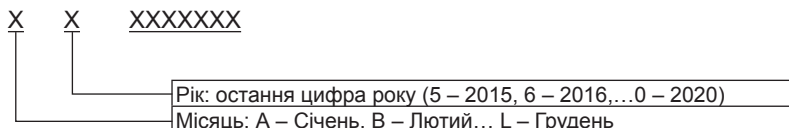

### Liquid crystal displays

Due to the characteristics of LCD monitors, prolonged display of bright still images or prolonged operation in high-temperature or high-humidity environments may result in residual images, luminance reduction, burn-in, banding, or panel defects and degradation that result in areas of permanently changed brightness.

In particular, avoid prolonged continuous display of the following types of images.

- Bright still images
- Images that include logomarks or graphics in fixed positions
- Windows from a computer and similar bright displays
- Images with aspect ratios different from that of the monitor (e.g., letterboxed images)

In addition, avoid prolonged continuous use in the following types of environments.

- Confined areas with high temperature and humidity
- Near the exhaust vent of air conditioning equipment, etc.

Prolonged use involving the images and environments described above will accelerate deterioration of the LCD panel over time.

To prevent accelerated deterioration and its related phenomena, we recommend the following.

- Do not display bright still images for prolonged periods.
  - Lower the brightness.
  - Turn off the power when the monitor is not in use.
- Residual images will gradually disappear as different images are displayed.

**Bitte lesen Sie zuerst diesen Hinweis!**
 ist die Sicherheitsinformation.
**WARNUNG:**

- Setzen Sie dieses Gerät zur Reduzierung der Brandgefahr weder Nässe noch Feuchtigkeit aus.
- Um die Brandgefahr zu reduzieren, muss dieses Gerät von allen Flüssigkeiten ferngehalten werden. Vermeiden sie Gebrauch und Lagerung des Gerätes an Orten, an denen die Gefahr besteht, dass es mit Flüssigkeiten betropft oder bespritzt wird, und stellen sie keine Flüssigkeitsbehälter auf das Gerät.

**WARNUNG:**

Halten Sie Zubehörteile (Kameranummernschild) stets fern von Babys und Kleinkindern.

**WARNUNG:**

Dieses Gerät ist mit der Klasse A von CISPR32 kompatibel.  
In einer Wohngegend kann dieses Gerät Funkstörungen verursachen.

**VORSICHT:**

Öffnen Sie nicht das Gerät durch Abschrauben von Gehäuseteilen.  
Im Geräteinneren befinden sich keine Teile, die vom Benutzer gewartet werden können.  
Wartungs- und Reparaturarbeiten grundsätzlich autorisiertem Kundendienstpersonal überlassen.

**VORSICHT:**

Verwenden Sie nur das empfohlene Zubehör, um die Gefahr von Bränden sowie Störungen zu reduzieren.

**VORSICHT:**

Um eine ausreichende Belüftung zu gewährleisten, dieses Gerät nicht in einem Bücherregal, Einbauschränk oder an einem anderen engen Platz aufstellen.  
Stellen Sie sicher, dass die Ventilationsöffnungen im Gehäuse nicht durch Vorhänge oder andere Materialien blockiert werden; anderenfalls besteht die Gefahr von Bränden aufgrund von Überhitzung.

**Hergestellt von:**

Panasonic Entertainment & Communication Co., Ltd.  
1-10-12, Yagumo-higashi-machi, Moriguchi City, Osaka, Japan

**Importeur:**

Panasonic Connect Europe GmbH  
Hagenauer Strasse 43, 65203 Wiesbaden, Deutschland

**Vertretungsberechtigter in der EU:**

Panasonic Connect Europe GmbH  
Panasonic Testing Centre  
Winsbergring 15, 22525 Hamburg, Deutschland

**Entsorgung von Altgeräten****Nur für die Europäische Union und Länder mit Recyclingsystemen**

Dieses Symbol, auf den Produkten, der Verpackung und/oder den Begleitdokumenten, bedeutet, dass gebrauchte elektrische und elektronische Produkte nicht in den allgemeinen Hausmüll gegeben werden dürfen.

Bitte führen Sie alte Produkte zur Behandlung, Aufarbeitung bzw. zum Recycling gemäß den gesetzlichen Bestimmungen den zuständigen Sammelpunkten zu.

Indem Sie diese Produkte ordnungsgemäß entsorgen, helfen Sie dabei, wertvolle Ressourcen zu schützen und eventuelle negative Auswirkungen auf die menschliche Gesundheit und die Umwelt zu vermeiden.

Für mehr Informationen zu Sammlung und Recycling, wenden Sie sich bitte an Ihren örtlichen Abfallentsorgungsdienstleister, Händler oder Zulieferer.

Gemäß Landesvorschriften können wegen nicht ordnungsgemäßer Entsorgung dieses Abfalls Strafgebühren verhängt werden.

## **EMV-HINWEIS FÜR DEN KÄUFER/ANWENDER DES GERÄTS**

### **1. Erforderliche Bedingungen zur Einhaltung der oben genannten Standards**

#### **<1> An das Gerät angeschlossene Geräte und spezielle Verbindungskabel**

- Der Käufer/Anwender sollte nur Geräte verwenden, die von uns als Zusatzgeräte für den Anschluss an das Gerät empfohlen wurden.
- Der Käufer/Anwender sollte nur die unten aufgeführten Verbindungskabel verwenden.

#### **<2> Für den Anschluss abgeschirmte Kabel verwenden, die dem Gerätezweck entsprechen**

- Videokabel  
Für SDI (Serial Digital Interface) doppelt abgeschirmte 75-Ohm HF-Koaxialkabel verwenden.  
Für analoge Videosignale werden 75-Ohm HF-Koaxialkabel empfohlen.
- Audiokabel  
Verwenden Sie Kabel für AES/EBU, wenn Ihr Gerät serielle digitale AES/EBU-Audiosignale unterstützt.  
Verwenden Sie für analoge Audiosignale abgeschirmte Kabel für hochwertige HF-Übertragungen.
- Weitere Kabel  
Verwenden Sie abgeschirmte Kabel für hochwertige HF-Anwendungen, wie Kabel für IEEE1394 oder USB.
- Verwenden Sie beim Anschließen der HDMI-Signal-Buchse mehrlagige abgeschirmte Kabel für eine Leistung mit hoher Qualität bei Anwendungen im Hochfrequenzbereich.
- Für die Verbindung zum DVI-Signalanschluss muss ein Kabel mit Ferritkern verwendet werden.
- Wird Ihr Gerät mit Ferritkernen geliefert, müssen diese an den Kabeln befestigt werden, siehe Angaben in dieser Anleitung.

### **2. Leistungsniveau**

Das Leistungsniveau des Geräts entspricht oder übersteigt das von diesen Standards verlangte Leistungsniveau. Das Gerät kann aber durch Nutzung in einer EMV-Umgebung, wie Bereichen mit starken elektromagnetischen Feldern (durch Sendemasten, Mobiltelefone etc.) störend beeinflusst werden. Um in diesen Situationen die störenden Einflüsse auf das Gerät zu minimieren wird empfohlen, folgende Schritte für betroffene Geräte und Betriebsumgebungen durchzuführen:

1. Positionieren Sie das Gerät von der Störquelle entfernt.
2. Ändern Sie die Geräteichtung.
3. Ändern Sie die Anschlussmethode des Geräts.
4. Schließen Sie das Gerät an eine andere Stromverbindung, die mit keinen weiteren Geräten geteilt wird.

## **Flussigkristall-Displays**

Aufgrund der Eigenschaften von LCD-Monitoren kann längeres Anzeigen von hellen Standbildern oder längerer Betrieb in Umgebungen mit hohen Temperaturen oder hoher Luftfeuchtigkeit zu Bildabdrücken, Leuchtdichtereduktion, Einbrennen, Trübung, oder Schäden und Verschlechterung des Panels führen, was in den betreffenden Bereichen die Helligkeit dauerhaft verändert.

Vermeiden Sie insbesondere die längere fortlaufende Anzeige der folgenden Bildertypen.

- Helle Standbilder
- Bilder, die Logos oder Grafiken in festen Positionen beinhalten
- Computerfenster und ähnliche helle Bildschirme
- Bilder mit vom Monitor abweichenden Seitenverhältnissen (z.B. LetterBox-Bilder)

Vermeiden Sie außerdem die längere fortlaufende Anzeige in den folgenden Umgebungen.

- Enge Bereiche mit hoher Temperatur und Luftfeuchtigkeit
- In der Nähe der Abluftöffnung von Klimaanlage etc.

Längere Verwendung mit den oben beschriebenen Bildern und Umgebungen beschleunigt die Verschlechterung des LCD-Bildschirms im Laufe der Zeit.

Um eine beschleunigte Verschlechterung und damit verbundene Phänomene zu vermeiden, empfehlen wir Folgendes.

- Zeigen Sie helle Standbilder nicht über einen längeren Zeitraum an.
- Reduzieren Sie die Helligkeit.
- Schalten Sie den Monitor aus, wenn dieser nicht benutzt wird.

Bildabdrücke werden allmählich verschwinden, wenn andere Bilder angezeigt werden.

## Lire ces informations en premier !

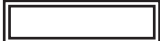
 Informations concernant la sécurité.

**AVERTISSEMENT:**

- Pour réduire les risques d'incendie, évitez d'exposer cet appareil à la pluie ou à l'humidité.
- Pour réduire les risques d'incendie, éloigner l'appareil des liquides — utiliser et ranger uniquement dans un endroit ne risquant pas de recevoir des gouttes ou d'être aspergé de liquides, et ne pas mettre de récipient renfermant des liquides sur le dessus de l'appareil.

**AVERTISSEMENT:**

Tenez toujours les accessoires (feuille d'immatriculation de caméra) hors de portée des bébés et jeunes enfants.

**AVERTISSEMENT:**

Cet appareil est conforme à la Classe A de la norme CISPR32.  
Dans un environnement résidentiel, cet appareil peut provoquer des interférences radio.

**NOTIFICATION (Canada)**

CAN ICES-003(A)/NMB-003(A)

**ATTENTION:**

Ne pas dévisser le couvercle.  
Il ne se trouve à l'intérieur aucune pièce qui puisse être réparée par l'utilisateur.  
Confier toute réparation à un personnel qualifié.

**ATTENTION:**

Pour réduire les risques d'incendie et des interférences nuisibles, utilisez uniquement les accessoires recommandés.

**ATTENTION:**

Pour maintenir une bonne ventilation, ne pas installer ni placer l'appareil dans une étagère, un meuble encastré ni aucun endroit confiné.  
Pour éviter tout risque d'incendie dû à une surchauffe, vérifiez qu'aucun rideau ni aucun autre matériau ne fait obstacle à la ventilation.

## IMPORTANTES MISES EN GARDE

- 1) Lire ces instructions.
- 2) Conserver ces instructions.
- 3) Respecter ces instructions.
- 4) Suivre toutes les instructions.
- 5) Ne pas utiliser cet appareil près de l'eau.
- 6) Nettoyer avec un chiffon sec seulement.
- 7) Ne pas bloquer les ouvertures pour ventilation. Installer selon les directives du fabricant.
- 8) Éloigner l'appareil de toute source de chaleur telle que radiateurs et autres éléments de chauffage (incluant les amplificateurs).
- 9) Ne pas tenter de contourner les mesures de sécurité des fiches polarisées ou de mise à la terre. Une fiche polarisée possède une lame plus large que l'autre. Une fiche avec mise à la terre possède une troisième broche pour la mise à la terre. Si la fiche ne peut pas être branchée, communiquer avec un électricien pour faire changer la prise de courant.
- 10) Protéger le cordon secteur de manière qu'il ne soit pas piétiné ou écrasé par des objets. Faire particulièrement attention à ses extrémités de branchement, y compris sa fiche.
- 11) N'utiliser que les accessoires recommandés par le fabricant.
- 12) Ne placer l'appareil que dans une baie ou un support recommandé par le fabricant.  
Déplacer la baie ou le support avec le plus grand soin afin d'en éviter le renversement.
- 13) Débrancher durant un orage ou lors de non-utilisation prolongée.
- 14) Confier toute réparation à un technicien qualifié. Faire réparer l'appareil si le cordon ou la fiche a été endommagé, si l'appareil a été mouillé, si un objet est tombé sur l'appareil, s'il a été exposé à la pluie ou à de l'humidité, s'il ne fonctionne pas normalement ou s'il a été échappé.



S3125A

## **NOTE D'INFORMATION SUR LA CEM POUR L'ACHETEUR/UTILISATEUR DE L'APPAREIL**

### **1. Conditions requises pour obtenir la conformité aux normes ci-dessus**

#### **<1> Equipements périphériques à connecter à l'appareil et câbles de connexion spéciaux**

- L'acheteur/utilisateur est invité à utiliser uniquement des équipements recommandés par notre société comme équipements périphériques à connecter à l'appareil.
- L'acheteur/utilisateur est invité à n'utiliser que les câbles de connexion décrits ci-dessous.

#### **<2> Pour les câbles de connexion, utilisez des câbles blindés appropriés à l'utilisation de l'appareil.**

- Câbles de connexion signal vidéo  
Utilisez des câbles coaxiaux blindés, conçus pour des applications à haute fréquence du type 75 ohms, pour la SDI (Serial Digital Interface).  
Les câbles coaxiaux, conçus pour des applications à haute fréquence du type 75 ohms, sont conseillés pour les signaux vidéo analogiques.
- Câbles de connexion signal audio  
Si votre appareil prend en charge les signaux audio numériques série AES/EBU, utilisez des câbles conçus pour AES/EBU. Utilisez des câbles blindés, qui assure des performances de qualité pour les applications de transmission haute fréquence, pour les signaux audio analogiques.
- Autres câbles de connexion  
Utilisez des câbles blindés, qui assurent des performances de qualité pour les applications haute fréquence, comme des câbles de connexion pour IEEE1394 ou USB.
- Lors de la connexion à la borne de signal HDMI, utilisez des câbles blindés multicouches, qui assurent des performances de qualité pour les applications haute fréquence.
- Lors du raccordement à la borne de signal DVI, utilisez un câble avec un noyau de ferrite.
- Si votre appareil est fourni avec un ou plusieurs tore(s) magnétique(s), ils doivent être fixés sur le(s) câble(s) selon les instructions figurant dans la présent manuel.

### **2. Niveau de performance**

Le niveau de performance de l'appareil est équivalent ou supérieur au niveau de performance requis par les normes en question.

Cependant, l'appareil pourrait être affecté de façon négative par des interférences s'il est utilisé dans un environnement CEM, tel qu'une zone où de forts champs électromagnétiques sont générés (par la présence de pylônes de transmission, téléphones portables etc.). Pour réduire au minimum les effets négatifs des interférences sur l'appareil dans des cas de ce genre, il est conseillé d'adopter les mesures suivantes en ce qui concerne l'appareil concerné et son environnement de fonctionnement:

1. Placez l'appareil à une certaine distance de la sources des interférences.
2. Changez la direction de l'appareil.
3. Changez la méthode de connexion utilisée pour l'appareil.
4. Connectez l'appareil à une autre prise électrique sur laquelle l'alimentation n'est partagée par aucun autre appareil.

### **Fabriqué par :**

Panasonic Entertainment & Communication Co., Ltd.  
1-10-12, Yagumo-higashi-machi, ville de Moriguchi, Osaka, Japon

### **Importateur :**

Panasonic Connect Europe GmbH  
Hagenauer Strasse 43, 65203 Wiesbaden, Allemagne

### **Représentant autorisé dans l'UE :**

Panasonic Connect Europe GmbH  
Panasonic Testing Centre  
Winsbergring 15, 22525 Hambourg, Allemagne



#### **L'élimination des équipements usagés**

**Applicable uniquement dans les pays membres de l'Union européenne et les pays disposant de systèmes de recyclage.**

Apposé sur le produit lui-même, sur son emballage, ou figurant dans la documentation qui l'accompagne, ce pictogramme indique que les appareils électriques et électroniques usagés, doivent être séparés des ordures ménagères.

Afin de permettre le traitement, la valorisation et le recyclage adéquats des appareils usagés, veuillez les porter à l'un des points de collecte prévus, conformément à la législation nationale en vigueur.

En les éliminant conformément à la réglementation en vigueur, vous contribuez à éviter le gaspillage de ressources précieuses ainsi qu'à protéger la santé humaine et l'environnement.

Pour de plus amples renseignements sur la collecte et le recyclage, veuillez vous renseigner auprès des collectivités locales, votre revendeur ou fournisseur.

Le non-respect de la réglementation relative à l'élimination des déchets est passible d'une peine d'amende.

## Affichage a cristaux liquides

En raison des caractéristiques des moniteurs LCD, l'affichage prolongé d'images fixes lumineuses ou le fonctionnement prolongé dans des environnements à température élevée ou à humidité élevée peut provoquer des images résiduelles, une réduction de la luminance, une surexposition, des effets de bandes ou des défauts et la détérioration du panneau, qui causeront l'apparition de zones à la luminosité irréversiblement altérée.

En particulier, évitez l'affichage continu prolongé des types d'images suivants.

- Images fixes lumineuses
- Images comprenant des logos ou des graphiques situés sur un emplacement fixe
- Fenêtres d'ordinateur et autres affichages lumineux de ce type
- Images avec des rapports de format différents de celui du moniteur (par ex. images au format "letterbox")

De plus, évitez l'utilisation continue prolongée dans les types d'environnements suivants.

- Zones confinées à la température et l'humidité élevées
- À proximité de l'évacuation d'air d'un dispositif de climatisation, etc.

L'utilisation prolongée impliquant les images et les environnements décrits ci-dessus accélérera la détérioration du panneau LCD au fil du temps.

Pour éviter la détérioration accélérée et les phénomènes qui y sont liés, nous vous recommandons de faire les choses suivantes.

- N'affichez pas d'images fixes pendant des périodes prolongées.
- Baissez la luminosité.
- Mettez le moniteur hors tension quand vous ne l'utilisez pas.

Les images résiduelles disparaissent progressivement lorsque des images différentes sont affichées.

## Leggere prima quanto segue!

 sono le informazioni sulla sicurezza.

### AVVISO:

- Per ridurre il pericolo di incendio, non esporre questa apparecchiatura a pioggia o umidità.
- Per ridurre il rischio d'incendio, tenere questo prodotto lontano da tutti i liquidi. Usarlo e conservarlo soltanto in luoghi che non siano esposti a gocciolamenti o spruzzi di liquidi, e non mettervi sopra recipienti di liquidi.

### AVVISO:

Conservare sempre accessori (targhetta numero videocamera) fuori dalla portata dei bambini.

### AVVISO:

Questa apparecchiatura è conforme alla Classe A della norma CISPR32.

In ambienti residenziali questa apparecchiatura potrebbe causare interferenze radio.

### PRECAUZIONE:

Non togliere il coperchio svitandolo.  
All'interno non ci sono parti riparabili dall'utente.  
Per le riparazioni, rivolgersi a personale tecnico qualificato.

### PRECAUZIONE:

Per ridurre il pericolo di incendio e di fastidiose interferenze, usare soltanto gli accessori raccomandati.

### PRECAUZIONE:

Per assicurare una buona ventilazione, non installare o sistemare questo apparecchio in uno scaffale, mobile incorporato od altro spazio chiuso. Per evitare il pericolo di incendio a causa di un surriscaldamento, accertarsi che tende o altri materiali non ostacolino la ventilazione.

### Fabbricato da:

Panasonic Entertainment & Communication Co., Ltd.  
1-10-12, Yagumo-higashi-machi, Città di Moriguchi, Osaka, Giappone

### Importatore:

Panasonic Connect Europe GmbH  
Hagenauer Strasse 43, 65203 Wiesbaden, Germania

### Rappresentante autorizzato nell'UE:

Panasonic Connect Europe GmbH  
Panasonic Testing Centre  
Winsbergring 15, 22525 Amburgo, Germania



### Smaltimento di vecchie apparecchiature

#### Solo per Unione Europea e Nazioni con sistemi di raccolta e smaltimento

Questo simbolo sui prodotti, sull'imballaggio e/o sulle documentazioni o manuali accompagnanti i prodotti indica che i prodotti elettrici, elettronici non devono essere smaltiti come rifiuti urbani ma deve essere effettuata una raccolta separata.

Per un trattamento adeguato, recupero e riciclaggio di vecchi prodotti vi invitiamo a portarli negli appositi punti di raccolta secondo la legislazione vigente nel vostro paese.

Con uno smaltimento corretto, contribuirete a salvare importanti risorse e ad evitare i potenziali effetti negativi sulla salute umana e sull'ambiente.

Per ulteriori informazioni su raccolta e riciclaggio, vi invitiamo a contattare il vostro comune, rivenditore o fornitore.

Lo smaltimento non corretto di questi rifiuti potrebbe comportare sanzioni in accordo con la legislazione nazionale.

## AVVISO EMC PER L'ACQUIRENTE/UTENTE DELL'APPARATO

### 1. Prerequisiti essenziali per la conformità agli standard sopra menzionati

#### <1> Periferiche da collegare all'apparato e cavi di collegamento speciali

- Si raccomanda all'acquirente/utente di collegare l'apparato esclusivamente con periferiche da noi approvate.
- Si raccomanda all'acquirente/utente di utilizzare esclusivamente i cavi di collegamento descritti in basso.

#### <2> Per i cavi di collegamento, utilizzare cavi schermati idonei per l'utilizzo previsto per l'apparato.

- Cavi di collegamento per segnali video  
Utilizzare cavi coassiali con doppia schermatura, progettati per applicazioni in alta frequenza da 75-ohm, per SDI (interfaccia digitale seriale).  
Per i segnali video analogici sono consigliati cavi coassiali, progettati per applicazioni in alta frequenza da 75-ohm.
- Cavi di collegamento per segnali audio  
Se l'apparato dell'utente supporta i segnali audio digitali seriali AES/EBU, utilizzare i cavi progettati per segnali AES/EBU.  
Per i segnali audio analogici, utilizzare cavi schermati che garantiscono prestazioni di qualità per le applicazioni di trasmissione ad alta frequenza.
- Altri cavi di collegamento  
Utilizzare cavi schermati che garantiscono prestazioni di qualità per le applicazioni ad alta frequenza, come i cavi di collegamento per IEEE1394 o USB.
- Per la connessione al terminale del segnale HDMI, utilizzare cavi schermati multistrato che garantiscono prestazioni di qualità per le applicazioni ad alta frequenza.
- Per la connessione al terminale del segnale DVI utilizzare un cavo dotato di anello in ferrite.
- Se l'apparato dell'utente dispone di anima/e in ferrite, questa deve essere attaccata al cavo o ai cavi come indicato nelle istruzioni che seguono nel presente manuale.

### 2. Livello di prestazioni

Il livello di prestazioni dell'apparato è equivalente o superiore al livello di prestazioni richiesto da questi standard. Tuttavia, l'apparato potrebbe essere disturbato da interferenze esterne qualora venga utilizzato in un ambiente EMC, come nel caso di un'area con forti campi elettromagnetici (generati dalla presenza di torri per la trasmissione di segnali, telefoni cellulari, ecc.). In casi simili, al fine di minimizzare il disturbo di tali interferenze sull'apparato, si consiglia di intervenire sull'apparato e sul suo ambiente operativo adottando le misure indicate di seguito:

1. Posizionare l'apparato lontano dalla fonte dell'interferenza.
2. Cambiare la direzione dell'apparato.
3. Cambiare il metodo di collegamento utilizzato per l'apparato.
4. Collegare l'apparato a un'altra presa sul muro che non sia condivisa con altri apparecchi.

## Display a cristalli liquidi

In virtù delle caratteristiche dei monitor LCD, la visualizzazione prolungata di immagini ferme luminose o il funzionamento durante un periodo di tempo prolungato in ambienti ad alta temperatura o ad alta umidità potrebbe generare immagini residuali, riduzione della luminosità, burn-in, banding o difetti e deterioramento del pannello con conseguente apparizione di zone in cui la luminosità si modifichi in modo irreversibile.

Nello specifico, evitare la visualizzazione continua prolungata dei seguenti tipi di immagine.

- Immagini ferme luminose
- Immagini che includono loghi o grafici in posizioni fisse
- Finestre di un computer o simili display luminosi
- Immagini con un rapporto di aspetto diverso da quello del monitor (es. immagini in formato letterbox)

Inoltre, evitare l'utilizzo continuo prolungato nei seguenti tipi di ambiente.

- Spazi chiusi con alta temperatura e umidità
- In prossimità di bocchette di scarico di impianti di aria condizionata, ecc.

Un uso prolungato con le immagini e negli ambienti menzionati accelera il deterioramento del pannello LCD nel tempo.

Per evitare il deterioramento accelerato e i fenomeni ad esso collegati, consigliamo quanto segue.

- Non visualizzare immagini ferme luminose per periodi di tempo prolungato.
- Ridurre la luminosità.
- Spegnerne l'alimentazione quando il monitor non è in uso.

Le immagini residuali scompariranno gradualmente con la visualizzazione di immagini diverse.

## Lea esto primero

 indica información de seguridad.

### ADVERTENCIA:

- Para reducir el riesgo de producir un incendio, no exponga este equipo a la lluvia ni a la humedad.
- Para reducir el riesgo de incendio, mantenga este equipo alejado de cualquier líquido. Utilícelo y guárdelo solamente en lugares donde no corra el riesgo de que le caigan gotas o le salpiquen líquidos, y no coloque ningún recipiente de líquidos encima del equipo.

### ADVERTENCIA:

Mantenga siempre los accesorios (placa con el número de cámara) fuera del alcance de los bebés o los niños pequeños.

### ADVERTENCIA:

Este equipo es compatible con la Clase A de CISPR32.  
En un entorno residencial, este equipo puede causar interferencias de radio.

### PRECAUCIÓN:

No quite la cubierta desatornillándola.  
Las piezas del interior no requieren mantenimiento por parte del usuario.  
Solicite las reparaciones al personal de servicio calificado.

### PRECAUCIÓN:

Para reducir el riesgo de incendios e interferencias molestas, utilice solamente los accesorios recomendados.

### PRECAUCIÓN:

Para mantener unas buenas condiciones de ventilación, no instale ni ponga este aparato en una librería, mueble empotrado u otro espacio reducido. Para evitar el riesgo de incendio debido al recalentamiento, asegúrese de que las cortinas y otros materiales no obstruyan la ventilación.

## INSTRUCCIONES DE SEGURIDAD IMPORTANTES

- 1) Lea estas instrucciones.
- 2) Guarde estas instrucciones.
- 3) Preste atención a todas las advertencias.
- 4) Siga todas las instrucciones.
- 5) No utilice este aparato cerca del agua.
- 6) Limpie solamente con un paño seco.
- 7) No bloquee ninguna abertura de ventilación. Instale el aparato según las instrucciones del fabricante.
- 8) No instale el aparato cerca de fuentes de calor como, por ejemplo, radiadores, registros de calor, estufas y otros aparatos (incluyendo amplificadores) que produzcan calor.
- 9) No anule la función de seguridad de la clavija polarizada o del tipo con conexión a tierra. Una clavija polarizada tiene dos patillas, una más ancha que la otra. Una clavija del tipo con conexión a tierra tiene dos patillas y un tercer contacto de conexión a tierra. La patilla ancha o el tercer contacto se incluyen para su seguridad. Si la clavija suministrada no se puede conectar en su toma de corriente, consulte a un electricista para que le sustituya la toma de corriente obsoleta.
- 10) Proteja el cable de alimentación para que nadie lo pise ni quede pellizcado, particularmente en la clavija, receptáculo de conveniencia y en el punto por donde sale del aparato.
- 11) Utilice solamente los aditamentos/accesorios especificados por el fabricante.
- 12) Utilice el aparato sólo con el carrito, soporte, trípode, ménsula o mesa especificado por el fabricante, o vendido con el aparato. Cuando utilice un carrito, tenga cuidado al mover la combinación del carrito/aparato para evitar lesiones debidas a vuelcos..



S3125A

## AVISO SOBRE CEM PARA EL COMPRADOR/USUARIO DEL APARATO

### 1. Condiciones previas para conseguir la conformidad con las normas mencionadas

#### <1> Equipo periférico por conectar al aparato y cables de conexión especiales

- Se recomienda que el comprador/usuario utilice solo equipos recomendados por nosotros como equipos periféricos que se pueden conectar al aparato.
- Se recomienda que el comprador/usuario utilice solo los cables de conexión descritos más abajo.

#### <2> Para los cables de conexión, utilizar cables apantallados que se ajusten al destino del aparato.

- Cables de conexión de señales de vídeo  
Utilizar cables coaxiales apantallados dobles, diseñados para aplicaciones de alta frecuencia del tipo de 75 ohm, para SDI (Interfaz digital en serie).  
Cables coaxiales, diseñados para aplicaciones de alta frecuencia del tipo de 75 ohm, están recomendados para señales de vídeo analógicas.
- Cables de conexión de señales de audio  
Si el aparato es compatible con las señales de audio digitales en serie AES/EBU, utilizar cables diseñados para AES/EBU.  
Utilizar cables apantallados, que proporcionan un rendimiento de calidad para aplicaciones de transmisión en alta frecuencia, para señales de audio analógicas.
- Otros cables de conexión  
Utilizar cables apantallados, que proporcionan un rendimiento de calidad para aplicaciones de transmisión en alta frecuencia, como cables de conexión para IEEE1394 o USB.
- Cuando se conecta al terminal de señales HDMI, utilizar cables apantallados multicapa, que proporcionan un rendimiento de calidad para aplicaciones de transmisión en alta frecuencia.
- Para conectar el terminal de señales DVI, utilice un cable con un núcleo de ferrita.
- Si el aparato está equipado con núcleo(s) de ferrita, tiene que conectarse al cable(s) siguiendo las instrucciones contenidas en este manual.

### 2. Nivel de rendimiento

El nivel de rendimiento del aparato es equivalente a o mejor respecto al nivel de rendimiento requerido por estas normas.

Sin embargo, el aparato puede quedar perjudicado por las interferencias si se está utilizando en un ambiente CEM, como una zona donde haya fuertes campos electromagnéticos (generados por la presencia de torres de transmisión de señales, teléfonos móviles, etc.). Para minimizar los efectos negativos de la interferencia en el aparato en casos como éste, se recomienda llevar a cabo las siguientes operaciones en el aparato afectado y en su ambiente de funcionamiento:

1. Colocar el aparato a cierta distancia de la fuente de la interferencia:
2. Cambiar de dirección el aparato.
3. Cambiar el método de conexión utilizado para el aparato.
4. Conectar el aparato a otra toma de corriente que no comparta su energía con otros dispositivos.

#### Fabricado por:

Panasonic Entertainment & Communication Co., Ltd.  
1-10-12, Yagumo-higashi-machi, Ciudad de Moriguchi, Osaka, Japón

#### Importador:

Panasonic Connect Europe GmbH  
Hagenauer Strasse 43, 65203 Wiesbaden, Alemania

#### Representante Autorizado para la UE:

Panasonic Connect Europe GmbH  
Panasonic Testing Centre  
Winsbergring 15, 22525 Hamburgo, Alemania



#### Eliminación de Aparatos Viejos

##### Solamente para la Unión Europea y países con sistemas de reciclado.

Este símbolo en los productos, su embalaje o en los documentos que los acompañen significa que los productos eléctricos y electrónicos usadas no deben mezclarse con los residuos domésticos.

Para el adecuado tratamiento, recuperación y reciclaje de los productos viejos llévelos a los puntos de recogida de acuerdo con su legislación nacional.

Si los elimina correctamente ayudará a preservar valiosos recursos y evitará potenciales efectos negativos sobre la salud de las personas y sobre el medio ambiente.

Para más información sobre la recogida o reciclaje, por favor contacte con su ayuntamiento, su distribuidor o su proveedor. Puede haber sanciones por una incorrecta eliminación de este residuo, de acuerdo con la legislación nacional.

## **Pantalla de cristal liquido**

Debido a las características de los monitores LCD, la visualización prolongada de imágenes fijas brillantes o el funcionamiento prolongado en entornos con una temperatura o humedad altas pueden producir imágenes residuales, reducción de la luminancia, quemaduras y franjas, o defectos y degradación en el panel que den lugar a áreas con el brillo cambiado permanentemente. En concreto, evite la visualización continua y prolongada de los siguientes tipos de imágenes.

- Imágenes fijas brillantes
- Imágenes que incluyen logos o gráficos en posiciones fijas
- Ventanas de un ordenador y visualizaciones brillantes similares
- Imágenes con relaciones de aspecto diferentes a las del monitor (por ejemplo, imágenes letterbox)

Además, evite el uso continuo y prolongado en los siguientes tipos de entorno.

- Áreas confinadas con alta temperatura y humedad
- Cerca de las salidas de ventilación de los equipos de aire acondicionado, etc.

El uso prolongado que incluye las imágenes y entornos descritos anteriormente acelerará el deterioro del panel LCD con el tiempo.

Para prevenir el deterioro acelerado y los fenómenos que este conlleva, recomendamos lo siguiente.

- No visualice imágenes fijas brillantes durante periodos prolongados.
- Baje el brillo.
- Desconecte la alimentación cuando el monitor no se utilice.

Las imágenes residuales desaparecerán gradualmente a medida que se visualicen diversas imágenes.

# Contents

---

|   |           |
|---|-----------|
| <b>Read this first!</b> .....                       | <b>3</b>  |
| <b>Bitte lesen Sie zuerst diesen Hinweis!</b> ..... | <b>7</b>  |
| <b>Lire ces informations en premier !</b> .....     | <b>9</b>  |
| <b>Leggere prima quanto segue!</b> .....            | <b>12</b> |
| <b>Lea esto primero</b> .....                       | <b>14</b> |
| <b>Before using the camera</b> .....                | <b>18</b> |
| <b>Features</b> .....                               | <b>18</b> |
| <b>Accessories</b> .....                            | <b>18</b> |
| <b>Description of parts</b> .....                   | <b>19</b> |
| Front .....   | 19        |
| Rear .....  | 20        |
| <b>Preparation</b> .....                            | <b>21</b> |
| Mounting to the camera .....                        | 21        |
| Dismounting from the camera .....                   | 21        |
| Tilting operation .....                             | 22        |
| Panning operation .....                             | 22        |
| Attaching the hood .....                            | 22        |
| <b>On-screen display</b> .....                      | <b>23</b> |
| Operation status display .....                      | 23        |
| Image adjustment knob condition display .....       | 23        |
| Function display .....                              | 24        |
| Mode check display .....                            | 24        |
| Camera menu display .....                           | 25        |
| <b>Menu operations</b> .....                        | <b>26</b> |
| Basic operations .....                              | 26        |
| Menu structure .....                                | 27        |
| Menu list .....                                     | 28        |
| <b>Maintenance and Inspection</b> .....             | <b>33</b> |
| <b>Specification</b> .....                          | <b>34</b> |
| Dimensions .....                                    | 34        |
| Specifications .....                                | 34        |
| Connector pin assignment table .....                | 35        |

- Various names, company names, product names, etc., described in this document are trademark or registered trademark of the respective companies.

## How to read this document

---

### ■ Illustrations

- The illustration may differ from actual product.

### ■ Conventions used in this manual

- Words and phrases in [ ] brackets indicate content displayed in the LCD monitor.
- Words and phrases in < > brackets indicate design text used on this camera, such as button names.

### ■ Reference pages

- Reference pages in this document are indicated by (page 00).

## Before using the camera

---

### ■ LCD

- The LCD monitor is manufactured with high-precision technology and has an effective pixel count of over 99.99%, but there are 0.01% of the pixels either missing or constantly lit (red, blue, green). This is normal and not a cause for concern.
- The LCD protective panel is specially treated. Wiping it or rubbing it vigorously with a hard cloth may scratch or mark its surface.
- The response rate and brightness of the LCD depend on the ambient temperature.

### ■ Handling

- Do not drop or apply excessive shock or vibration. Doing so may damage it.

### ■ Operating temperature range

- The picture quality may degrade or there may be adverse effect to internal components when used in locations as follows. Avoid using in such locations.

Cold location that is 0 °C (32 °F) or lower.

Hot location that is 45 °C (113 °F) or higher.

### ■ Maintenance

- Clean the cabinet and LCD protection panel by gently wiping them with a soft cloth.  
To remove stubborn soiling, use a cloth dampened in a weak neutral detergent solution and thoroughly wrung out. Then wipe with a dry cloth.  
Any moisture entering the monitor could damage it.
- Never use alcohol, thinner, or benzene to clean this unit.  
Doing so may discolor the surface or cause the paint to peel.
- Do not directly expose the monitor to spray detergent. Any moisture entering the monitor could damage it.

### ■ Connecting/disconnecting the connector

- Be sure to power down the device before connecting or disconnecting the connector.

## Features

---

This unit is an LCD viewfinder equipped with a 7.0-inch LCD panel.

This can be used as a viewfinder for the Studio Handy Camera (AK-UC3300G/AK-UC3300GS, AK-HC3900G/AK-HC3900GS, AK-UC4000G/AK-UC4000GS, AK-UC3000G/AK-UC3000GS, AK-HC5000G/AK-HC5000GS, AK-HC3800G/AK-HC3800GS).

The signal for video format is automatically distinguished and displays the video of the camera.

Setting for various markers, focus assist function, waveform display function, etc., can be set regardless of setting the viewfinder setting on this unit.

These functions can be assigned to the <F1> to <F3> buttons, and can be displayed directly by pressing the button.

## Accessories

---

### Hood

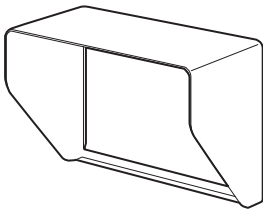

### Camera number sheet (1 to 12)

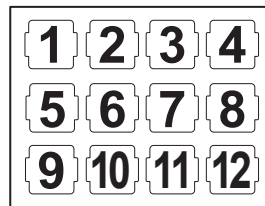

### NOTE

- After unpacking the product, dispose of the packing material properly.

## Description of parts

### Front

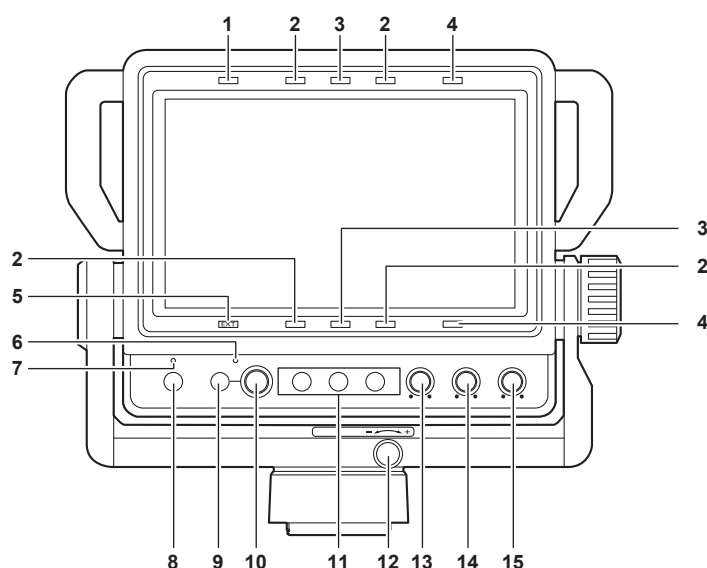

#### 1 Assignable tally lamp

This is illuminated with the condition set in [MAIN MENU] → [SYSTEM CONFIG] → [TALLY ASSIGN].  
The brightness can be switched with [MAIN MENU] → [TALLY BRIGHT] → [FRONT TALLY] → [HIGH]/[MID]/[LOW].

#### 2 Red tally lamp

This is illuminated when the red tally signal is input.  
The brightness can be switched with [MAIN MENU] → [TALLY BRIGHT] → [FRONT TALLY] → [HIGH]/[MID]/[LOW].

#### 3 Green tally lamp

This is illuminated when the green tally signal is input.  
The brightness can be switched with [MAIN MENU] → [TALLY BRIGHT] → [FRONT TALLY] → [HIGH]/[MID]/[LOW].

#### 4 Yellow tally lamp

This is illuminated when the yellow tally signal is input.  
The brightness can be switched with [MAIN MENU] → [TALLY BRIGHT] → [FRONT TALLY] → [HIGH]/[MID]/[LOW].

#### 5 <EXT> lamp

This is illuminated when the lens extender is used.  
The brightness can be switched with [MAIN MENU] → [TALLY BRIGHT] → [FRONT TALLY] → [HIGH]/[MID]/[LOW].

#### 6 <ADJ> lamp

The lamp (green) is illuminated during adjustment.  
This is illuminated when [FUNCTION] → [ASSIGN] is set to anything other than [UNDEF].

#### 7 <POWER> lamp

The lamp (green) is illuminated when the power is turned on.  
Turns off when set to [MAIN MENU] → [SYSTEM CONFIG] → [POWER LED] → [OFF1]/[OFF2].

#### 8 <POWER> button

This is the button to turn on/off the power.  
The power can be turned off by pressing this switch for two seconds or longer while the power is turned on.

#### 9 <MENU> button

This switches on/off of the menu.

#### 10 <SELECT> dial button

This is a dial button for menu screen operation.  
The cursor will move down when the <SELECT> dial button is turned clockwise. The cursor will move up when turned counterclockwise.  
To select a menu item, press the <SELECT> dial button.  
Sets the function to assigned with [MAIN MENU] → [FUNCTION] → [ASSIGN].

#### 11 <F1> to <F3> buttons

A function can be assigned to each button with [MAIN MENU] → [FUNCTION] → [FUNCTION1] to [FUNCTION3].  
The function assigned to each is operated by pressing the button. For details, refer to [FUNCTION] (page 29).

#### 12 <FRICTION> knob

This adjusts the operation torque of panning.  
The operation torque is increased when turned toward the <+> side and decreased when turned to the <-> side.

#### 13 <BRIGHT> knob

This adjusts the brightness of the image.

#### 14 <CONTRAST> knob

This adjusts the contrast of the image.

#### 15 <PEAKING> knob

This adjusts the contour correction of the image.

## Description of parts

### NOTE

- The brightness for assignable tally lamp/<EXT> lamp/red tally lamp/green tally lamp/yellow tally lamp are switched simultaneously when the setting of [FRONT TALLY] is changed.

## Rear

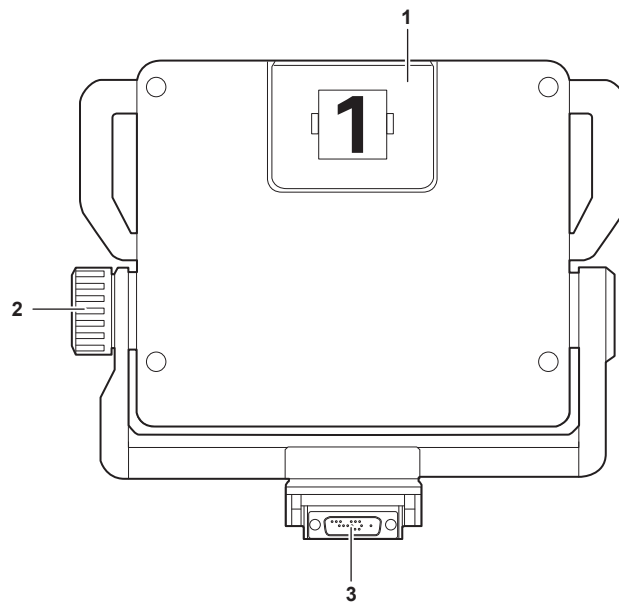

### 1 Up tally lamp

This is illuminated with the control signal from the camera.

The brightness can be switched with [MAIN MENU] → [TALLY BRIGHT] → [UP TALLY] → [HIGH]/[LOW]/[OFF].

The camera number sheet (accessory) can be attached.

### 2 <TILT LOCK> knob

This adjusts the operation torque of tilting.

The operation torque is increased when turned more toward the arrow symbol indicated on the knob. (page 22)

### 3 Camera I/F connector

This is the terminal to connect to the Studio Handy Camera (AK-UC3300G/AK-UC3300GS, AK-HC3900G/AK-HC3900GS, AK-UC4000G/AK-UC4000GS, AK-UC3000G/AK-UC3000GS, AK-HC5000G/AK-HC5000GS, AK-HC3800G/AK-HC3800GS).

## Preparation

### Mounting to the camera

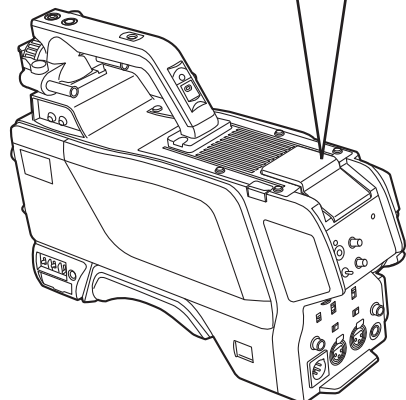
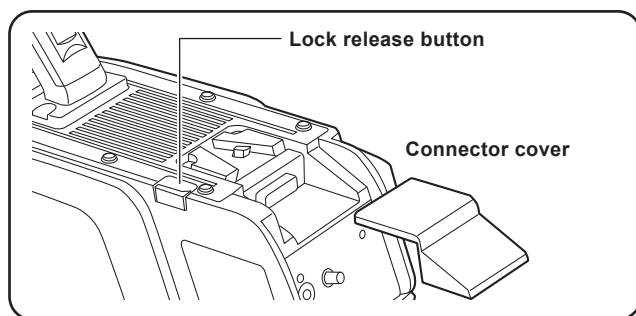

Fig. 1

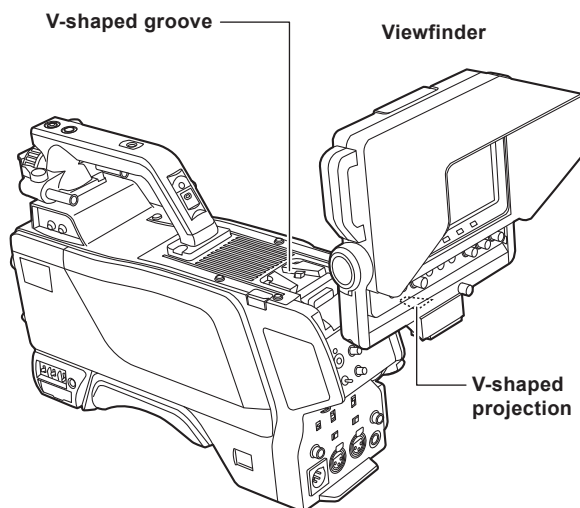

Fig. 2

- 1** Turn off the power of the camera and this unit.
- 2** Press the lock release button on the camera and remove the connector cover. (Fig. 1)
- 3** Align the V-shaped projection of this unit to the V-shaped groove on the camera, and slide and push in until it is locked. (Fig. 2)  
Once the mounting is completed, confirm that the viewfinder is securely mounted to the camera and the <FRICTION> and <TILT LOCK> knobs are locked.

#### NOTE

- Do not hold on the hood of this unit when mounting.

### Dismounting from the camera

- 1** Turn off the power of the camera and this unit.
- 2** Slide and dismount this unit while pressing the lock release button on the camera.  
After dismounting the unit, attach the connector cover to prevent dusts, etc. from entering in the D-sub connector.

#### NOTE

- Do not hold on the hood of this unit when dismounting.

## Tilting operation

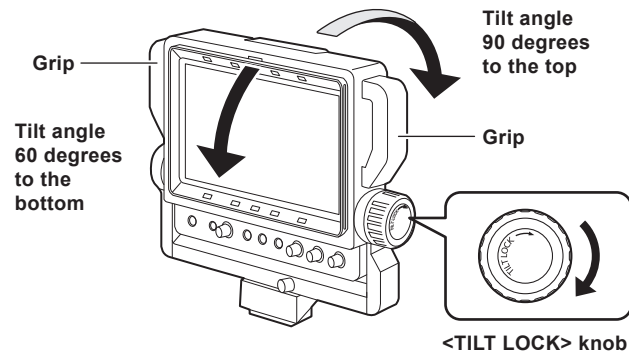

The operation torque is increased when the <TILT LOCK> knob is turned toward the direction of the arrow. Adjust the torque adequately and hold the grip when operating the tilting.

### NOTE

- Do not hold onto the hood of the unit when operating the tilting.

## Panning operation

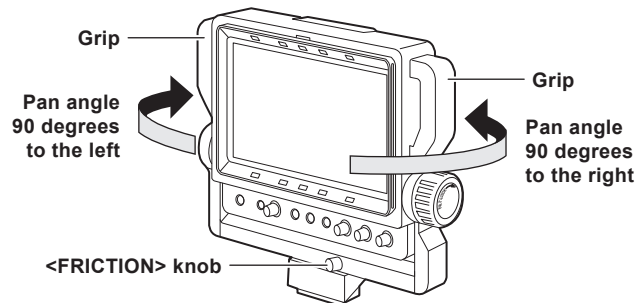

The operation torque is increased when the <FRICTION> knob is turned toward the <+> side and decreased when turned to the <-> side. Adjust the torque adequately and hold the grip when operating the panning.

### NOTE

- Do not hold onto the hood of the unit when operating the panning.

## Attaching the hood

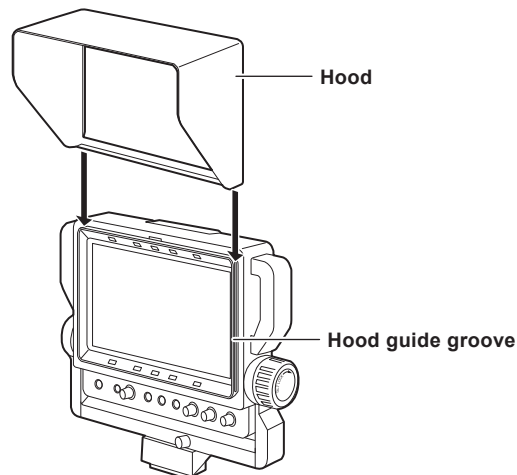

Slide the edge of the hood along the hood guide groove downwards when attaching the hood.  
Slide the hood upwards when removing the hood.

## On-screen display

The operation status, functions, image adjustment condition, menus and other information are displayed in the viewfinder screen.

### Operation status display

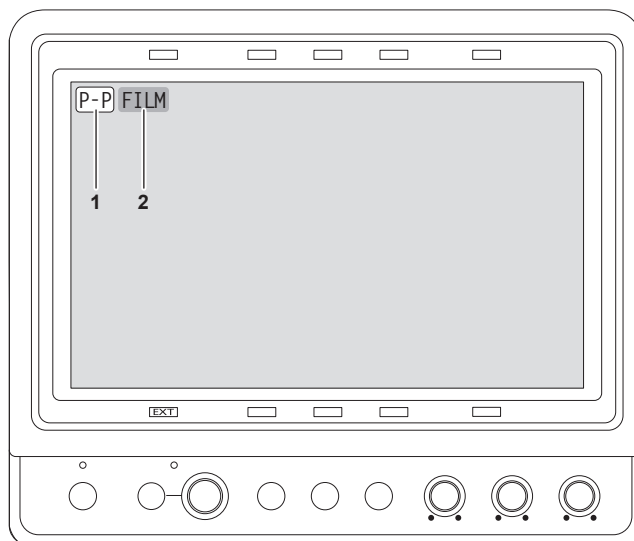

**1 PIXEL TO PIXEL mode**

Displayed when image display is in the PIXEL TO PIXEL mode.

**2 Film mode**

Displayed when set to [MAIN MENU] → [VIDEO CONFIG] → [GAMMA SELECT] → [FILM].

### Image adjustment knob condition display

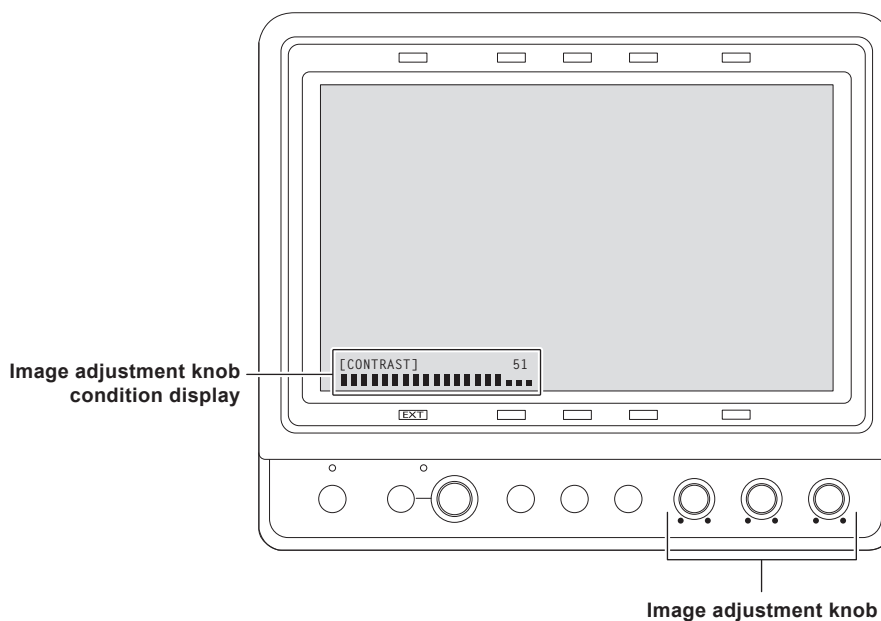

Name and adjustment value of the knob currently being operated is displayed when operating one of the image adjustment knobs <BRIGHT>/<CONTRAST>/<PEAKING>.

- This display disappears after approximately two seconds of inaction.

## Function display

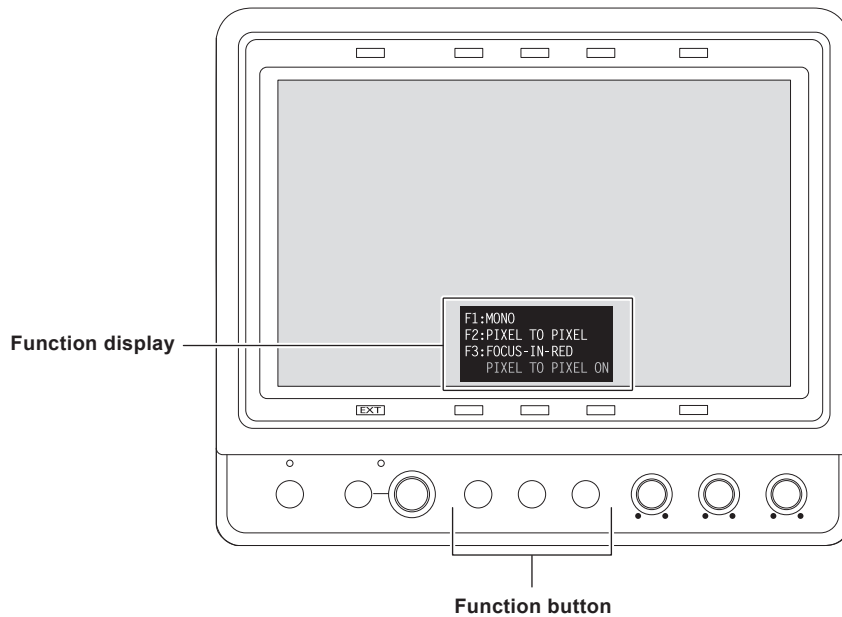

### 1 Press one of the <F1> to <F3> buttons.

Assigned function and its condition are displayed when operating one of the <F1> to <F3> buttons.

- This display disappears after approximately two seconds of inaction.
- Display condition can be changed with [MAIN MENU] → [FUNCTION] → [FUNCTION DISPLAY].

## Mode check display

Current setting condition can be displayed.

Perform while the menu is not displayed.

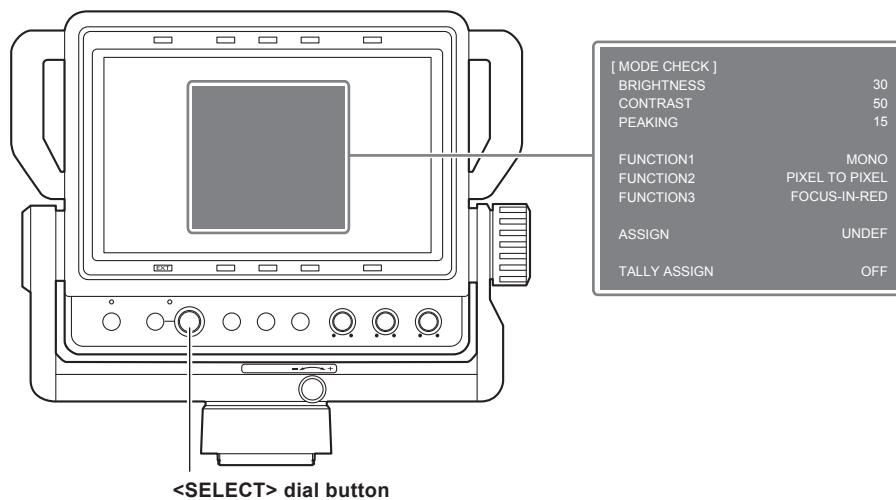

### 1 Press the <SELECT> dial button.

The setting condition is displayed.

Display disappears when there is approximately two minutes of inaction.

- **[BRIGHTNESS]:** The value adjusted with the <BRIGHT> knob
- **[CONTRAST]:** The value adjusted with the <CONTRAST> knob
- **[PEAKING]:** The value adjusted with the <PEAKING> knob
- **[FUNCTION1]:** Function assigned to the <F1> button
- **[FUNCTION2]:** Function assigned to the <F2> button
- **[FUNCTION3]:** Function assigned to the <F3> button
- **[ASSIGN]:** Function assigned to the <SELECT> dial button
- **[TALLY ASSIGN]:** The illumination condition set with [MAIN MENU] → [SYSTEM CONFIG] → [TALLY ASSIGN]

## Camera menu display

The menu of the camera (only AK-UC3300G/AK-UC3300GS, AK-HC3900G/AK-HC3900GS, AK-UC4000G/AK-UC4000GS, AK-UC3000G/AK-UC3000GS, AK-HC5000G/AK-HC5000GS) can be operated from this unit.

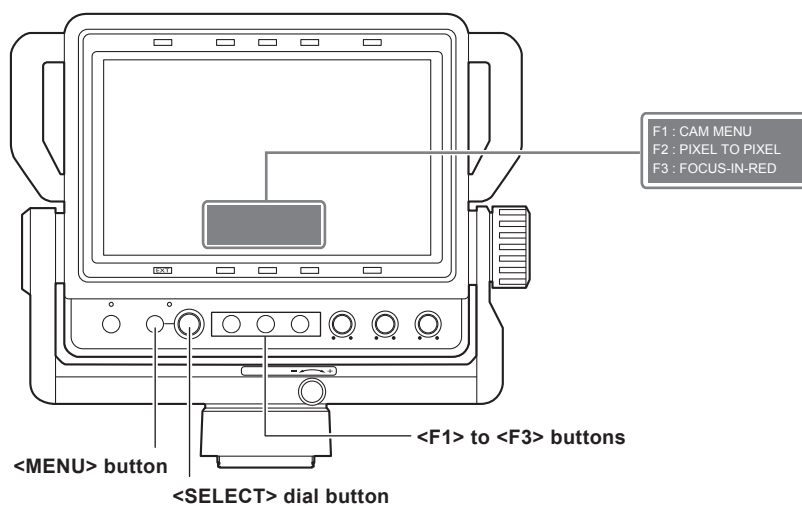

- 1** Set [CAM MENU] to one of the <F1> to <F3> buttons in [MAIN MENU] → [FUNCTION] → [FUNCTION1] to [FUNCTION3].
- 2** Press one of the <F1> to <F3> buttons that [CAM MENU] is set.
- 3** Press the <MENU> button.  
The menu screen of the camera is displayed.
- 4** Turn the <SELECT> dial button and select the item.
- 5** Press the <SELECT> dial button.  
For the operating method of the menu, refer to the Operating Instruction of the camera.

### NOTE

- The setting for [CAM MENU] is cleared when the power is turned off.

# Menu operations

The menu operation method, structure of the setting menu, and details of the setting menu are described.

## Basic operations

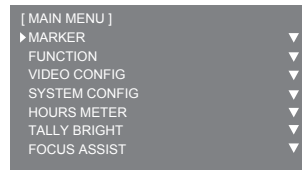
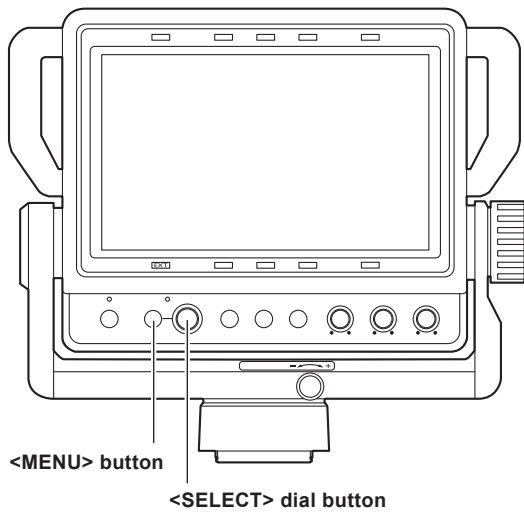

Fig. 1

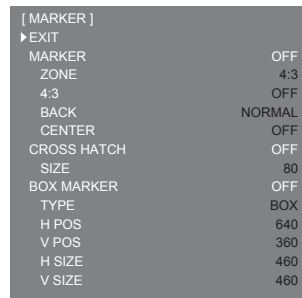

Fig. 2

**1 Press the <MENU> button.**

[MAIN MENU] is displayed. (Fig. 1)

Previous menu is displayed by pressing the <MENU> button when [MAIN MENU] → [SYSTEM CONFIG] → [MENU RESUME] → [ON] is set. [MAIN MENU] is displayed when the power is turned off once and then turned on again.

**2 Turn the <SELECT> dial button and select the menu item.**

**3 Press the <SELECT> dial button.**

The selected item is opened. (Fig. 2)

**4 Turn the <SELECT> dial button and select the item to set.**

**5 Press the <SELECT> dial button.**

The setting value changes to green.

**6 Turn the <SELECT> dial button and change the setting.**

To cancel, press the <MENU> button.

**7 Press the <SELECT> dial button.**

The setting is confirmed.

**NOTE**

- This display disappears after approximately two minutes of inaction. The value displayed at that time will be confirmed as the setting value when the display disappears.

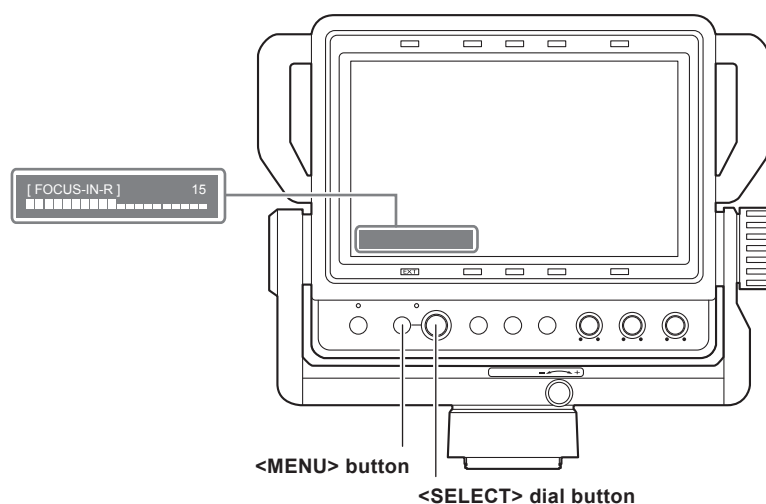
**[ASSIGN] setting ([ASSIGN] condition display)**

- 1** Select the function to be assigned to the <SELECT> dial button with [MAIN MENU] → [FUNCTION] → [ASSIGN].
- 2** Press the <SELECT> dial button.
- 3** Press the <MENU> button to close the menu.
- 4** Turn the <SELECT> dial button to change the setting.
  - The function that is being operated and its adjustment value are displayed.
  - This display disappears after approximately two seconds of inaction.

**Key lock setting**

Operation of the <F1> to <F3> buttons, <SELECT> dial button, and <MENU> button can be disabled. The <POWER> button, <BRIGHT> knob, <CONTRAST> knob, and <PEAKING> knob cannot be disabled.

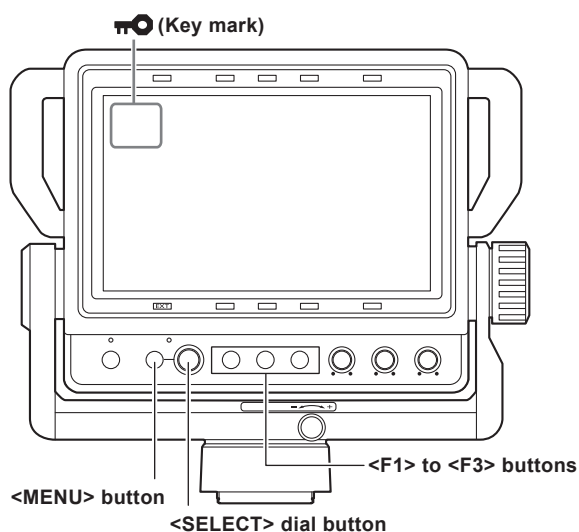

- 1** Press the <SELECT> dial button while operating to display the mode check display, and then press and hold the <MENU> button for three seconds or longer.

A key mark is constantly displayed at the top left of the screen while in key lock.

- The setting is cleared when the power is turned off.
- To clear the key lock, press and hold the <MENU> button for three seconds or longer.

**Menu structure**

|             |                 |   |
|-------------|-----------------|---|
| [MAIN MENU] | [MARKER]        | Performs the setting regarding the marker.                                |
|             | [FUNCTION]      | Performs the setting regarding the operation of the <F1> to <F3> buttons. |
|             | [VIDEO CONFIG]  | Performs the setting regarding the screen.                                |
|             | [SYSTEM CONFIG] | Performs the setting regarding the system.                                |
|             | [HOURS METER]   | Displays the elapsed time and illuminated time of the backlight.          |
|             | [TALLY BRIGHT]  | Sets the brightness of the up tally lamp and front tally lamp.            |
|             | [FOCUS ASSIST]  | Sets the function of the focus assist.                                    |

## Menu list

## [MARKER]

| Item          | Setting content  |
|---------------|--|
| [EXIT]        | Returns to the upper level.  |
| [MARKER]      | —<br>Sets if the marker is displayed in the screen or not.<br><b>[ON], [OFF]</b><br>• Factory setting: [OFF]<br>[BOX MARKER] is set to [OFF] when [BOX MARKER] is [ON1]/[ON2] and [MARKER] is set to [ON].   |
| [ZONE]        | Selects the type of marker.<br><b>[OFF]</b> : Marker is not displayed.<br><b>[4:3]</b> : Marker of 4:3 size.<br><b>[13:9]</b> : Marker of 13:9 size.<br><b>[14:9]</b> : Marker of 14:9 size.<br><b>[CNSCO2.39]</b> : Marker of 2.39:1 size.<br><b>[CNSCO2.35]</b> : Marker of 2.35:1 size.<br><b>[2:1]</b> : Marker of 2:1 size.<br><b>[VISTA]</b> : Marker of 1.85:1 size.<br><b>[95%]</b> : Marker of 95% area.<br><b>[93%]</b> : Marker of 93% area.<br><b>[90%]</b> : Marker of 90% area.<br><b>[88%]</b> : Marker of 88% area.<br><b>[80%]</b> : Marker of 80% area.<br><b>[USER85%]</b> : Variable area marker between the range of 80% to 100% (in 1% steps) (can be set by pressing the <SELECT> dial button and the setting value changes to light blue) (factory setting is [85%])<br>• Factory setting: [4:3] |
| [4:3]         | Selects the type of marker displayed when the image aspect ratio is 4:3.<br><b>[OFF]</b> : Marker is not displayed.<br><b>[95%]</b> : Marker of 95% area.<br><b>[93%]</b> : Marker of 93% area.<br><b>[90%]</b> : Marker of 90% area.<br><b>[88%]</b> : Marker of 88% area.<br><b>[80%]</b> : Marker of 80% area.<br><b>[USER85%]</b> : Variable area marker between the range of 80% to 100% (in 1% steps) (can be set by pressing the <SELECT> dial button and the setting value changes to light blue) (factory setting is [85%])<br>• Factory setting: [OFF]   |
| [BACK]        | Sets the background brightness outside the marker set with [ZONE].<br><b>[NORMAL]</b> : Normal background.<br><b>[HALF]</b> : Background brightness is set to 50%.<br><b>[BLACK]</b> : Background brightness is set to 0% (black).<br>• Factory setting: [NORMAL]  |
| [CENTER]      | Sets if the center marker is displayed or not.<br><b>[ON], [OFF]</b><br>• Factory setting: [OFF]   |
| [CROSS HATCH] | —<br>Sets the display and density of the cross hatch.<br><b>[OFF]</b> : Does not display.<br><b>[LOW]</b> : Dim cross hatch is displayed.<br><b>[HIGH]</b> : Bright cross hatch is displayed.<br>• Factory setting: [OFF]  |
| [SIZE]        | Selects the cross hatch size.<br><b>[80]</b> : 80 dots and 80 lines<br><b>[40]</b> : 40 dots and 40 lines<br>• Factory setting: [80]   |
| [BOX MARKER]  | —<br>Sets if the box marker is displayed in the screen or not. Two patterns of [ON1] and [ON2] can be recorded.<br><b>[ON1], [ON2], [OFF]</b><br>• Factory setting: [OFF]<br>[MARKER] is set to [OFF] when [MARKER] is [ON] and [BOX MARKER] is set to [ON1]/[ON2].  |
| [TYPE]        | Sets the display type of the box marker.<br><b>[BOX]</b> : Box type display.<br><b>[CROSS]</b> : Cross type display.<br>• Factory setting: [BOX]   |
| [H POS]       | Sets the horizontal position to display the box marker.<br><b>[10]...[1270]</b> (in 10 dots step)<br>• Factory setting: [640]  |
| [V POS]       | Sets the vertical position to display the box marker.<br><b>[10]...[710]</b> (in 10 lines step)<br>• Factory setting: [360]  |
| [H SIZE]      | Sets the horizontal size of the box marker.<br><b>[10]...[1270]</b> (in 10 dots step)<br>• Factory setting: [460]  |
| [V SIZE]      | Sets the vertical size of the box marker.<br><b>[10]...[710]</b> (in 10 lines step)<br>• Factory setting: [460]  |

**[FUNCTION]**

| Item        | Setting content  |
|-------------|--|
| [EXIT]      | Returns to the upper level.  |
| [FUNCTION1] | <p>Selects the function assigned to the &lt;F1&gt; button.</p> <p><b>[SCAN]:</b> Switches between the underscan and normal display.</p> <p><b>[WFM]:</b> Displays the waveform display screen.</p> <p><b>[MARKER]:</b> Displays the marker.</p> <p><b>[PIXEL TO PIXEL]:</b> Switches the enable/disable of the PIXEL TO PIXEL function *1*2.</p> <p><b>[FOCUS-IN-RED]:</b> Switches the enable/disable of the function to enhance the focused part of the image (disabled when [WFM] is displayed, disabled when there is no input signal, setting is cleared when the power is turned off, and the detection sensitivity can be changed with the &lt;SELECT&gt; dial button during the operation when [FOCUS-IN-RED] is assigned with [MAIN MENU] → [FUNCTION] → [ASSIGN]).</p> <p><b>[CROSS HATCH]:</b> Switches the cross hatch display.</p> <p><b>[MONO]:</b> Switches between the color and monochrome display.</p> <p><b>[UP TALLY]:</b> Switches the on/off of the up tally lamp.</p> <p><b>[FRONT TALLY]:</b> Switches the brightness of the front tally lamp.</p> <p><b>[CAM MENU]:</b> Switches the enable/disable of the camera menu operation function (setting is canceled when the power is turned off).</p> <p><b>[FOCUS ASSIST]:</b> Switches the enable/disable of the focus assist function on the camera.</p> <p><b>[ZOOM LINK]:</b> Switches the enable/disable of the detail function on the viewfinder linked with the zoom.</p> <p><b>[UNDEF]:</b> Function is not assigned.</p> <ul style="list-style-type: none"> <li>• Factory setting: [MONO]</li> </ul> <p>[CAM MENU], [FOCUS ASSIST], and [ZOOM LINK] can be operated only when the camera (AK-UC3300G/AK-UC3300GS, AK-HC3900G/AK-HC3900GS, AK-UC4000G/AK-UC4000GS, AK-UC3000G/AK-UC3000GS, AK-HC5000G/AK-HC5000GS) is connected.</p>           |
| [FUNCTION2] | <p>Selects the function assigned to the &lt;F2&gt; button.</p> <p><b>[SCAN]:</b> Switches between the underscan and normal display.</p> <p><b>[WFM]:</b> Displays the waveform display screen.</p> <p><b>[MARKER]:</b> Displays the marker.</p> <p><b>[PIXEL TO PIXEL]:</b> Switches the enable/disable of the PIXEL TO PIXEL function *1*2.</p> <p><b>[FOCUS-IN-RED]:</b> Switches the enable/disable of the function to enhance the focused part of the image (disabled when [WFM] is displayed, disabled when there is no input signal, setting is cleared when the power is turned off, and the detection sensitivity can be changed with the &lt;SELECT&gt; dial button during the operation when [FOCUS-IN-RED] is assigned with [MAIN MENU] → [FUNCTION] → [ASSIGN]).</p> <p><b>[CROSS HATCH]:</b> Switches the cross hatch display.</p> <p><b>[MONO]:</b> Switches between the color and monochrome display.</p> <p><b>[UP TALLY]:</b> Switches the on/off of the up tally lamp.</p> <p><b>[FRONT TALLY]:</b> Switches the brightness of the front tally lamp.</p> <p><b>[CAM MENU]:</b> Switches the enable/disable of the camera menu operation function (setting is canceled when the power is turned off).</p> <p><b>[FOCUS ASSIST]:</b> Switches the enable/disable of the focus assist function on the camera.</p> <p><b>[ZOOM LINK]:</b> Switches the enable/disable of the detail function on the viewfinder linked with the zoom.</p> <p><b>[UNDEF]:</b> Function is not assigned.</p> <ul style="list-style-type: none"> <li>• Factory setting: [PIXEL TO PIXEL]</li> </ul> <p>[CAM MENU], [FOCUS ASSIST], and [ZOOM LINK] can be operated only when the camera (AK-UC3300G/AK-UC3300GS, AK-HC3900G/AK-HC3900GS, AK-UC4000G/AK-UC4000GS, AK-UC3000G/AK-UC3000GS, AK-HC5000G/AK-HC5000GS) is connected.</p> |
| [FUNCTION3] | <p>Selects the function assigned to the &lt;F3&gt; button.</p> <p><b>[SCAN]:</b> Switches between the underscan and normal display.</p> <p><b>[WFM]:</b> Displays the waveform display screen.</p> <p><b>[MARKER]:</b> Displays the marker.</p> <p><b>[PIXEL TO PIXEL]:</b> Switches the enable/disable of the PIXEL TO PIXEL function *1*2.</p> <p><b>[FOCUS-IN-RED]:</b> Switches the enable/disable of the function to enhance the focused part of the image (disabled when [WFM] is displayed, disabled when there is no input signal, setting is cleared when the power is turned off, and the detection sensitivity can be changed with the &lt;SELECT&gt; dial button during the operation when [FOCUS-IN-RED] is assigned with [MAIN MENU] → [FUNCTION] → [ASSIGN]).</p> <p><b>[CROSS HATCH]:</b> Switches the cross hatch display.</p> <p><b>[MONO]:</b> Switches between the color and monochrome display.</p> <p><b>[UP TALLY]:</b> Switches the on/off of the up tally lamp.</p> <p><b>[FRONT TALLY]:</b> Switches the brightness of the front tally lamp.</p> <p><b>[CAM MENU]:</b> Switches the enable/disable of the camera menu operation function (setting is canceled when the power is turned off).</p> <p><b>[FOCUS ASSIST]:</b> Switches the enable/disable of the focus assist function on the camera.</p> <p><b>[ZOOM LINK]:</b> Switches the enable/disable of the detail function on the viewfinder linked with the zoom.</p> <p><b>[UNDEF]:</b> Function is not assigned.</p> <ul style="list-style-type: none"> <li>• Factory setting: [FOCUS-IN-RED]</li> </ul> <p>[CAM MENU], [FOCUS ASSIST], and [ZOOM LINK] can be operated only when the camera (AK-UC3300G/AK-UC3300GS, AK-HC3900G/AK-HC3900GS, AK-UC4000G/AK-UC4000GS, AK-UC3000G/AK-UC3000GS, AK-HC5000G/AK-HC5000GS) is connected.</p>   |

## Menu operations

| Item               | Setting content   |
|--------------------|---|
| [ASSIGN]           | <p>Selects the function assigned to the &lt;SELECT&gt; dial button when the menu is not displayed.</p> <p><b>[FOCUS-IN-RED]:</b> Changes the detection sensitivity of the function to enhance the part that is focused in the image.</p> <p><b>[IN-RED-COLOR]:</b> Switches the display color of the function to enhance the part that is focused in the image.</p> <p><b>[VF DTL]:</b> Adjusts the detail level of the viewfinder.</p> <p><b>[MARKER BACK]:</b> Switches the background brightness of outside for the marker set in [MAIN MENU] → [MARKER] → [ZONE].</p> <p><b>[BOX MARKER VF]:</b> Switches the enable/disable of the box marker display on this unit.</p> <p><b>[BOX MARKER CAM]:</b> Switches the enable/disable of the box marker display on the camera.</p> <p><b>[ZOOM LINK LEVEL]:</b> Switches the detail level of the viewfinder linked with the zoom.</p> <p><b>[UNDEF]:</b> Function is not assigned.</p> <ul style="list-style-type: none"> <li>• Factory setting: [UNDEF]</li> </ul> <p>[VF DTL], [BOX MARKER CAM], and [ZOOM LINK LEVEL] can be operated only when the camera (AK-UC3300G/AK-UC3300GS, AK-HC3900G/AK-HC3900GS, AK-UC4000G/AK-UC4000GS, AK-UC3000G/AK-UC3000GS, AK-HC5000G/AK-HC5000GS) is connected.</p> |
| [FUNCTION DISPLAY] | <p>Selects the display setting and the operation setting (one touch, two touches) for the function assigned to the &lt;F1&gt; to &lt;F3&gt; buttons.</p> <p><b>[OFF]:</b> Does not display the function.</p> <p><b>[ON1]:</b> Displays the function simultaneously as setting the operation. (One touch)</p> <p><b>[ON2]:</b> The function is displayed first, and then the operation is set by pressing the &lt;F1&gt; to &lt;F3&gt; buttons. (Two touches)</p> <ul style="list-style-type: none"> <li>• Factory setting: [ON1]</li> </ul>   |

\*1 The setting is cleared when the power is turned off.

\*2 Center part of the screen is displayed in enlarged display. A [P-P] mark is displayed at the top left of the screen while in operation.

## [VIDEO CONFIG]

| Item             | Setting content   |
|------------------|---|
| [EXIT]           | Returns to the upper level.   |
| [GAMMA SELECT]   | <p>Selects the gamma curve.*</p> <p><b>[STANDARD]:</b> Standard mode.</p> <p><b>[FILM]:</b> Film mode (displays [FILM] at the top left of the screen).</p> <ul style="list-style-type: none"> <li>• Factory setting: [STANDARD]</li> </ul>  |
| [FILM GAMMA]     | <p>Selects the type of the film gamma mode in accordance with the gamma setting on the camera.*</p> <p><b>[FILM REC]:</b> When [FILM REC] is selected.</p> <p><b>[OTHER]:</b> When anything other than [FILM REC] is selected.</p> <div style="text-align: center;"> <p><b>Conceptual diagram of gamma curve</b></p> <p>The diagram shows a grid with 'Input level' on the x-axis and 'Brightness' on the y-axis. Three curves are plotted: a solid line for [OTHER], a dashed line for [FILM REC], and a solid line for [STANDARD]. The [FILM REC] curve is the steepest, followed by [STANDARD], and [OTHER] is the least steep.</p> </div> <ul style="list-style-type: none"> <li>• Factory setting: [FILM REC]</li> </ul> |
| [COLOR TEMP.]    | <p>Selects the color temperature.</p> <p><b>[USER 0]...[USER 63]:</b> Variable settings 0 to 63 (equivalent to color temperature of 3000 K to 9300 K) (can be set when the &lt;SELECT&gt; dial button is pressed and the setting value changes to light blue).</p> <p><b>[D93]:</b> Equivalent to color temperature of 9300 K</p> <p><b>[D65]:</b> Equivalent to color temperature of 6500 K</p> <p><b>[D56]:</b> Equivalent to color temperature of 5600 K</p> <ul style="list-style-type: none"> <li>• Factory setting: [D65]</li> </ul>  |
| [SHARPNESS MODE] | <p>Selects the edge width of the contour correction (during peaking).</p> <p><b>[HIGH]:</b> Narrow edge</p> <p><b>[LOW]:</b> Wide edge</p> <ul style="list-style-type: none"> <li>• Factory setting: [HIGH]</li> </ul>  |
| [SHARPNESS H]    | <p>Sets the horizontal contour correction.</p> <p>Adds to the operation of the &lt;PEAKING&gt; knob.</p> <p><b>[0]...[30]</b></p> <ul style="list-style-type: none"> <li>• Factory setting: [0]</li> </ul>  |
| [SHARPNESS V]    | <p>Sets the vertical contour correction.</p> <p>Adds to the operation of the &lt;PEAKING&gt; knob.</p> <p><b>[0]...[30]</b></p> <ul style="list-style-type: none"> <li>• Factory setting: [0]</li> </ul>  |
| [MONO]           | <p>Switches between color and monochrome.</p> <p><b>[OFF]:</b> Color.</p> <p><b>[ON]:</b> Monochrome.</p> <ul style="list-style-type: none"> <li>• Factory setting: [OFF]</li> </ul>  |

| Item   | Setting content  |
|--------|--|
| [SCAN] | Sets the underscan or normal display of the screen.<br><b>[NORMAL]</b> : Normal display.<br><b>[UNDER]</b> : Underscan.<br>• Factory setting: [NORMAL] |

\* Correct image is not displayed when the gamma setting is different from the setting of the camera.

### [SYSTEM CONFIG]

| Item             | Setting content   |
|------------------|---|
| [EXIT]           | Returns to the upper level.   |
| [WFM]            | Sets if the waveform of the video signal input to viewfinder is displayed or not.<br><b>[FOCUS-IN-RED]</b> is disabled when [WFM] is displayed while <b>[FOCUS-IN-RED]</b> is enabled.<br><b>[OFF]</b> : Not displayed.<br><b>[ON]</b> : Displays the waveform of the brightness signal.<br>• Factory setting: [OFF]  |
| [WFM POSITION]   | Selects the position of the waveform display when [WFM] is [ON].<br><b>[LB]</b> : Bottom left of the screen.<br><b>[RB]</b> : Bottom right of the screen.<br><b>[RT]</b> : Top right of the screen.<br><b>[LT]</b> : Top left of the screen.<br>• Factory setting: [RB]   |
| [TALLY ASSIGN]   | Sets the illumination condition of the assignable tally lamp.<br><b>[OFF]</b> : Turns off.<br><b>[CAM MENU]</b> : Turns on when the menu operation function of the camera is enabled. This is enabled only when the camera (AK-UC3300G/AK-UC3300GS, AK-HC3900G/AK-HC3900GS, AK-UC4000G/AK-UC4000GS, AK-UC3000G/AK-UC3000GS, AK-HC5000G/AK-HC5000GS) is connected.<br><b>[LED]</b> : Turns on when it matches the setting on the camera. This is enabled only when the camera (AK-UC3300G/AK-UC3300GS, AK-HC3900G/AK-HC3900GS, AK-UC4000G/AK-UC4000GS) is connected.<br>• Factory setting: [OFF] |
| [MENU RESUME]    | Sets the enable/disable of the menu resume function.<br><b>[OFF]</b> , <b>[ON]</b><br>• Factory setting: [OFF]  |
| [POWER LED]      | Sets the illumination condition of the <POWER> lamp.<br><b>[ON]</b> : Turns on continuously.<br><b>[OFF1]</b> : Turns off (setting will return to [ON] when the power is turned off/on).<br><b>[OFF2]</b> : Turns off continuously.<br>• Factory setting: [ON]  |
| [POWER RESUME]   | Sets whether to remember the status when the unit is turned off with the <POWER> button.<br><b>[ON]</b> : Remember the status.<br><b>[OFF]</b> : Does not remember the status.<br>The unit turns on when power is supplied from the camera.<br>• Factory setting: [ON]  |
| [STATUS DISPLAY] | Sets the display condition of the status display.<br><b>[CONTINUE]</b> : Displays continuously.<br><b>[3SEC OFF]</b> : Displays for three seconds after changing the condition of the status display, and then disappears.<br><b>[OFF]</b> : Not displayed.<br>• Factory setting: [3SEC OFF]  |

### [HOURS METER]

| Item        | Setting content   |
|-------------|---|
| [EXIT]      | Returns to the upper level.   |
| [OPERATION] | Displays the total number of hours the power was turned on.<br>Hours up to 262800 hours [262800H] (approximately 30 years) is displayed. Hours exceeding 262800 hours is displayed as [OVER]. |
| [LCD]       | Displays the number of hours the backlight has been on.<br>Hours up to 262800 hours [262800H] (approximately 30 years) is displayed. Hours exceeding 262800 hours is displayed as [OVER].     |

## Menu operations

### [TALLY BRIGHT]

| Item          | Setting content  |
|---------------|--|
| [EXIT]        | Returns to the upper level.  |
| [UP TALLY]    | Sets the brightness of the up tally lamp.<br><b>[HIGH]</b> : Turns on (bright).<br><b>[LOW]</b> : Turns on (dark).<br><b>[OFF]</b> : Turns off.<br>• Factory setting: [LOW]            |
| [FRONT TALLY] | Sets the brightness of the front tally lamp.<br><b>[HIGH]</b> : Turns on (bright).<br><b>[MID]</b> : Turns on (medium).<br><b>[LOW]</b> : Turns on (dark).<br>• Factory setting: [MID] |

### [FOCUS ASSIST]

| Item           | Setting content  |
|----------------|--|
| [EXIT]         | Returns to the upper level.  |
| [FOCUS-IN-RED] | —<br>Sets the enable/disable of the function to enhance the part that is focused in the image on this unit. Disabled while [WFM] is displayed. Disabled when there is no input signal. (setting is canceled when the power is turned off)<br><b>[OFF], [ON]</b><br>• Factory setting: [OFF]  |
| [IN-RED-COLOR] | Sets the display color of the function to enhance the part that is focused in the image on this unit.<br><b>[RED], [GREEN], [BLUE], [WHITE]</b><br>• Factory setting: [RED]  |
| [ZOOM LINK]    | —<br>Sets the enable/disable of the detail function on the viewfinder linked with the zoom.<br><b>[OFF], [ON]</b><br>• Factory setting: [OFF]<br>This item can be operated only when the camera (AK-UC3300G/AK-UC3300GS, AK-HC3900G/AK-HC3900GS, AK-UC4000G/AK-UC4000GS, AK-UC3000G/AK-UC3000GS, AK-HC5000G/AK-HC5000GS) is connected. |
| [LINK LEVEL]   | Sets the detail level of the viewfinder linked with the zoom.<br><b>[LOW], [MID], [HIGH]</b><br>• Factory setting: [LOW]   |
| [FOCUS ASSIST] | Sets the enable/disable of the focus assist function on the camera.<br><b>[OFF], [ON]</b><br>• Factory setting: [OFF]<br>This item can be operated only when the camera (AK-UC3300G/AK-UC3300GS, AK-HC3900G/AK-HC3900GS, AK-UC4000G/AK-UC4000GS, AK-UC3000G/AK-UC3000GS, AK-HC5000G/AK-HC5000GS) is connected.                         |

## Maintenance and Inspection

---

Maintenance and inspection are performed with periodic and appropriate maintenance to maintain the function of the unit in constantly good condition so the customers can use the unit safely.

Make sure to execute the maintenance and inspection for the function of the unit to last long in good condition.

### ■ Periodic maintenance service

The LCD panel is equipped with a backlight. The backlight is a consumable component that deteriorates and eventually breaks down.

Therefore, it is important to perform a periodic maintenance service on top of the conventional service performed at the time of failure. The performance of the device is maintained in good condition, and unexpected failure due to consumable parts can be avoided by the maintenance service.

# Specification

## Dimensions

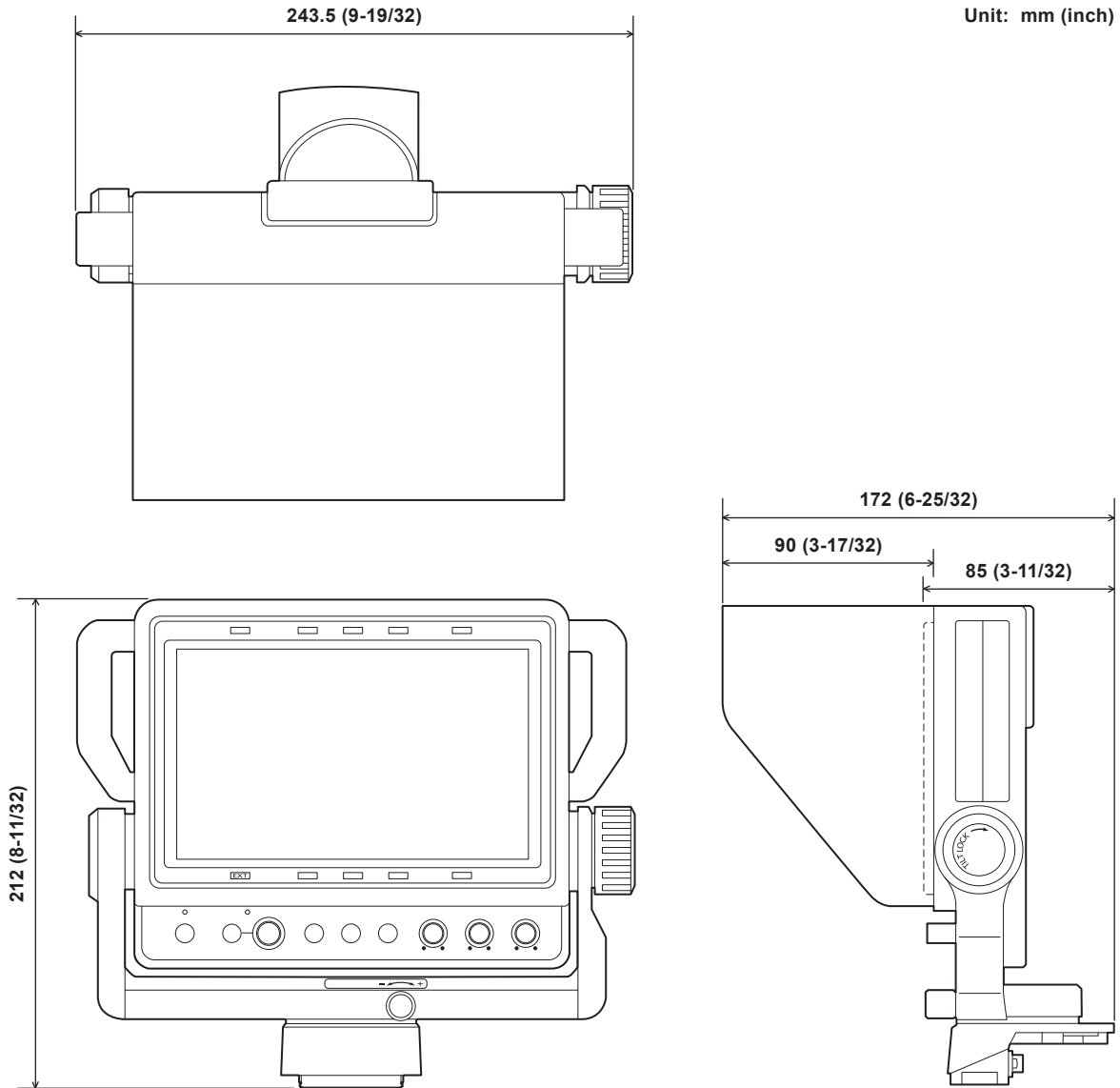

## Specifications

### General

Power  
 DC = 12 V (supplied from camera)  
 Power consumption  
 11 W

indicates safety information.

|                               |   |
|-------------------------------|---|
| Ambient operating temperature | 0 °C – 45 °C (32 °F – 113 °F)   |
| Storage temperature           | -20 °C – 60 °C (-4 °F – 140 °F)   |
| Ambient operating humidity    | 10% – 85% (no condensation)   |
| Weight                        | Approx. 1.6 kg (3.53 lbs.) (not including hood)   |
| Dimensions (W×H×D)            | 243.5 mm×212 mm×85 mm<br>(9-19/32 inches × 8-11/32 inches × 3-11/32 inches)<br>(not including hood)<br>243.5 mm×212 mm×172 mm<br>(9-19/32 inches × 8-11/32 inches × 6-25/32 inches)<br>(including hood) |

**Display panel**

|                  |                              |
|------------------|------------------------------|
| Dimensions       | 7.0 inches                   |
| Number of pixels | 1280×800 (WXGA)              |
| Display color    | Approx. 16.77 million colors |

**Switch function/connector**

|           |   |
|-----------|---|
| Operation | <POWER> switch<br><MENU> button<br><SELECT> dial button<br><F1>/<F2>/<F3> buttons<br><BRIGHT> knob<br><CONTRAST> knob<br><PEAKING> knob |
| Connector | Camera I/F connector (D-sub 29 pins × 1)  |

**Supported signal format**

|     |                       |
|-----|-----------------------|
| CAM | 1080/59.94i, 1080/50i |
|-----|-----------------------|

**Connector pin assignment table**

Camera I/F connector (D-sub 29 pins)

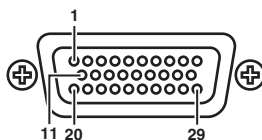

|    |                |    |                    |    |          |
|----|----------------|----|--------------------|----|----------|
| 1  | Y              | 11 | Y GND              | 21 | Not used |
| 2  | P <sub>B</sub> | 12 | P <sub>B</sub> GND | 22 | Not used |
| 3  | P <sub>R</sub> | 13 | P <sub>R</sub> GND | 23 | Not used |
| 4  | CAM DET        | 14 | AGND               | 24 | I2C CLK  |
| 5  | I2C DATA       | 15 | DGND               | 25 | G TALLY  |
| 6  | R TALLY        | 16 | Not used           | 26 | P REQ    |
| 7  | UP TALLY       | 17 | UNREG-GND          | 27 | Not used |
| 8  | Not used       | 18 | Not used           | 28 | Not used |
| 9  | VF12 V         | 19 | FGND               | 29 | Not used |
| 10 | Not used       | 20 | (LCD ACT)          |    |          |

D02-29PF-N-F0 (Japan Aviation Electronics Industry)

**Panasonic Entertainment & Communication Co., Ltd.**

Web Site: <https://pro-av.panasonic.net/en/>

© Panasonic Entertainment & Communication Co., Ltd. 2019 - 2024