

## Operating Instructions

### Replacement Lamp Unit Commercial Use

---

Model No. ET-LAEF100C

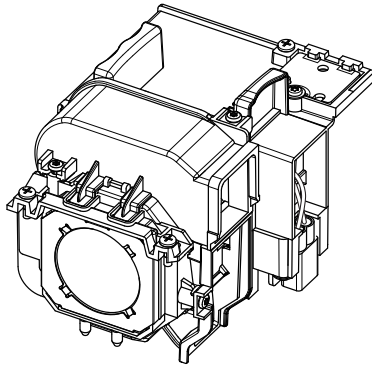

Thank you for purchasing this Panasonic product.

- Please read these operating instructions and the projector operating instructions carefully, and then use this product correctly.
- **Before using this product, be sure to read “Read this first!” (➡ Page 2).**
- Please save this manual for future use.

# Contents

Read this first!.....	2
Replacing the lamp unit.....	4
Before replacing the lamp unit.....	4
Switching off the projector.....	4
Replacing the lamp unit.....	5

## Read this first!

Always follow these precautions

### WARNING:

**Before replacing the lamp unit, be sure to turn the power off and to disconnect the power plug from the wall outlet.**

- Electric shocks or explosions can result if this is not done.

**Do not disassemble the lamp unit.**

- If the lamp breaks, it could cause injury.

**Do not remove unspecified screws during the lamp unit replacement.**

- Doing so can cause electric shocks, burns, or injury.

**Replace the lamp unit after the lamp has cooled (after waiting at least one hour).**

- The high temperature inside the cover will cause burns.

### WARNING:



**TURN THE POWER OFF AND DISCONNECT THE POWER PLUG FROM THE WALL OUTLET BEFORE REPLACING THE LAMP UNIT.**

### ■ Illustrations in this manual

- Pictures shown are illustrations of PT-SLZ71C in this manual, other models have their own characteristics and may be different from them.

### ■ Term

- In this manual, the supplied "Wireless/wired remote control unit" or "Wireless remote control unit" in the projector is referred to as "Remote control".

## Read this first! (continued)

### Name and quantity of hazardous substances contained in the product

Part Name	Hazardous substances					
	Lead (Pb)	Mercury (Hg)	Cadmium (Cd)	Hexavalent Chromium (Cr(VI))	Polybrominated Biphenyl (PBB)	Polybrominated Diphenyl Ether (PBDE)
Printed circuit boards	×	○	○	○	○	○
Projection lamp	×	×	○	○	○	○
Mechanical parts	×	○	○	○	○	○

This table is prepared in accordance with the provisions of SJ/T 11364.

- : The amount of hazardous substances included in all homogeneous materials for the relevant part does not exceed the limit specified in GB/T 26572.
- ×: The amount of hazardous substances included in all homogeneous materials for the relevant part exceeds the limit specified in GB/T 26572.



The Environmentally Friendly Use Period (EFUP) for the projection lamp is 5 years.

# Replacing the lamp unit

- Be sure to turn off the power before replacing the lamp unit.
- When switching off the projector, make sure to follow the procedures in “Switching off the projector” (➔ page 4).
- It is recommended that you request a qualified technician to replace the lamp unit. Consult your dealer.

## Before replacing the lamp unit

### Attention

- Since the luminous lamp is made of glass, it may burst if dropped or hit with a hard object. Handle with care.
- Do not disassemble or modify the lamp unit.
- When replacing the lamp unit, be sure to hold it by the handle because its surface is pointed and its shape is protruded.
- The lamp may rupture. Replace the lamp unit carefully so the glass fragments of the lamp do not scatter. While attaching the projector to the ceiling, do not work right under the lamp unit or do not conduct work while your face is near the lamp unit.
- The lamp contains mercury. When disposing of used lamp units, contact your local authorities or dealer for correct methods of disposal.

### Note

- A Phillips screwdriver is necessary when replacing the lamp unit.

## Switching off the projector

When the projector is operating, perform the following steps to turn off the projector, and wait until the lamp unit cools off then make the replacement.

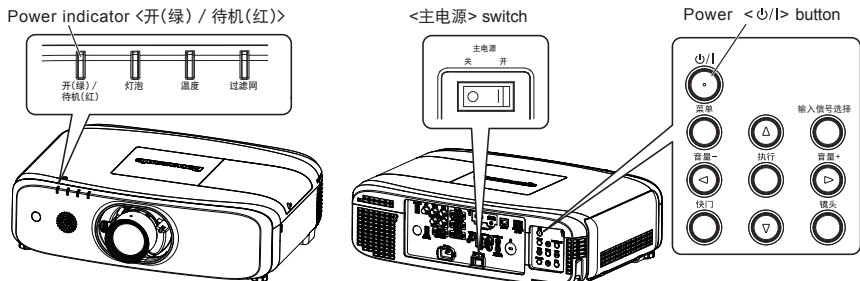

- 1) Press the power **<⏻/⏻>** button on the control panel or on the remote control.
  - The [POWER OFF] confirmation screen is displayed.
- 2) Press **<◀▶>** to select [OK], and press the **<执行>** button.  
(Or press the power **<⏻/⏻>** button again.)
  - Projection of the image will stop, and the power indicator **<开(绿)/待机(红)>** on the projector body lights in orange. (The fans keep running.)
- 3) Wait until the power indicator **<开(绿)/待机(红)>** on the projector body lights or blinks in red.
- 4) Press the **<关>** side of the **<主电源>** switch to turn off the power.

## Replacing the lamp unit (continued)

### Replacing the lamp unit

#### Attention

- When the projector is mounted on the ceiling, do not make the replacement while your face is near the lamp unit.

#### 1) Set the <主电源> switch to <关> and disconnect the power plug from the power outlet.

- Wait at least one hour and check if the lamp unit has cooled down.

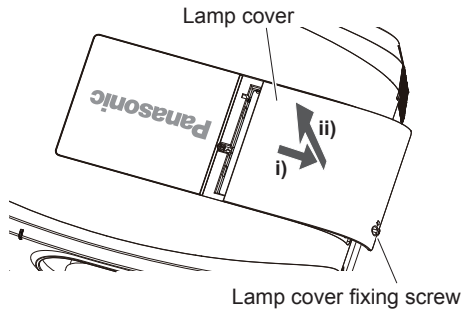

Fig. 1

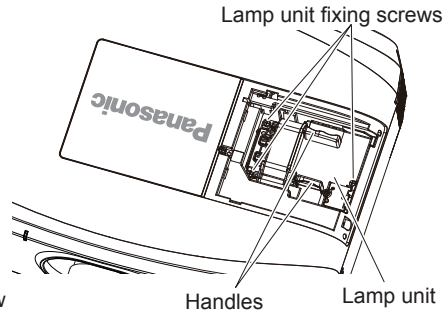

Fig. 2

#### 2) Remove the lamp cover. (Fig. 1)

- Use a Phillips screwdriver to turn the lamp cover fixing screw (x1) counterclockwise until it turns freely, and slide and pull up the lamp cover slowly in the direction of the arrow to remove it.
- Opening the lamp cover quickly may result in falling.

#### 3) Remove the lamp unit. (Fig. 2)

- Use a Phillips screwdriver to turn the lamp unit fixing screws (x3) counterclockwise until they turn freely, and remove the lamp unit.
- Hold the handles of the lamp unit and remove it straight.

#### 4) Push in the new lamp unit while paying attention to the insertion position.

- If the lamp unit is not installed properly, remove it and then push it in slowly. Pushing it in quickly or forcibly may break the connector.

#### 5) Use a Phillips screwdriver to firmly tighten the lamp unit fixing screws (x3).

- Make sure to attach the lamp unit securely.

#### 6) Attach the lamp cover.

- Perform Step 2) in the reverse order to attach the lamp cover.
- Use a Phillips screwdriver to firmly tighten the lamp cover fixing screw (x1).
  - Make sure to attach the lamp cover slowly and securely.

#### Note

- When you replace the lamp unit with new one, the projector resets the total usage time of the lamp unit automatically.

#### Attention

- After unpacking the lamp unit, discard the packaging material properly.

## ■ Information on Disposal in other Countries outside the European Union



This symbol is only valid in the European Union.  
If you wish to discard this product, please contact your local authorities  
or dealer and ask for the correct method of disposal.



---

## 松下影像科技（广东）有限公司

广东省东莞市塘厦镇宏业工业区

网站: <https://prosystem.panasonic.cn>

**原产地：中国**

**发行：2025 年 4 月**

© 松下影像显示株式会社 2025 版权所有  
本产品按照企业标准：Q/PCG 4 设计制造

LT0216JY2045 -PT  
Printed in China