



MINOLTA®







2VIEW







MND33



User Manual

1.0 Introduction	5
1.1 Buttons and Operation Overview	15
1.2 Buttons and Operation Overview Explained	17
1.3 Camera Features and Operation	19
1.4 Operating the Battery Door	20
1.5 Installing the Battery	21
1.5 Installing the Memory Card	22
1.6 Charging the Battery	23
1.7 Powering the Camera On and Off	24
1.8 Connecting to a Computer	25
1.9 Selecting the USB Connection Mode	26
1.10 Transferring Media to PC	27
1.11 Camera Mode Settings Menu Explanation	29
1.12 Using the LED Flash / Video Light	30
1.13 Shooting Modes	32
1.13.1 Photo Mode 	32
1.13.2 Video Mode 	33
1.13.3 Time Lapse (Video) Mode 	34
1.13.4 Slow-Motion Mode 	35
1.13.5 Self-Timer Photo Mode 	36
1.13.6 Playback Mode 	36
1.14 Using the Front LCD Monitor	37
1.15 Using Digital Zoom	38
2.0 Photo Mode 	39
2.1 Photo Capture Screen Icons	41
2.2 Capturing a Photo	43
2.3 Photo Mode Settings	44
2.4 Adjusting Photo Resolution	45
2.5 Interval Shooting	46
2.6 Photo Burst Setting	47
2.7 Adjusting Photo Quality	48
2.8 Applying Color Filter	49
2.9 Adjusting White Balance	50
2.10 Adjusting ISO Setting	51
2.11 Adjusting Exposure Value	52
2.12 Adjusting Metering Mode	53

2.13 Adjusting LED Settings	54
2.14 Adjusting Shutter Sound	55
3.0 Video Mode 	56
3.1 Video Capture Screen Icons	57
3.2 Capturing a Video	59
3.3 Video Mode Settings	61
3.4 Adjusting Video Resolution	62
3.5 Video Recording Sound	63
3.6 Loop Recording	64
3.7 Adjusting Video Quality	65
3.8 Applying Color Filter	66
3.9 Adjusting White Balance	67
3.10 Adjust ISO Setting	68
3.11 Adjusting Contrast	69
3.12 Adjusting Exposure Value	70
3.13 Adjusting Metering Mode	71
3.14 Adjusting LED Settings	72
4.0 Time Lapse Mode 	73
4.1 Time Lapse Mode Settings	75
4.1 Adjusting Time Lapse Video Resolution	76
4.2 Setting the Time Lapse Duration	77
4.3 Adjusting Video Quality (Time Lapse Mode)	78
4.4 Applying a Color Filter (Time Lapse Mode)	79
4.5 Adjusting White Balance (Time Lapse Mode)	80
4.6 Adjusting ISO Setting (Time Lapse Mode)	81
4.7 Adjusting Contrast (Time Lapse Mode)	82
4.8 Adjusting Exposure (Time Lapse Mode)	83
4.9 Adjusting Metering Mode (Time Lapse Mode)	84
4.10 Adjusting LED Settings (Time Lapse Mode)	85
5.0 Slow Motion Mode 	86
5.1 Slow Motion Settings	88
5.2 Adjusting Slow Motion Resolution	89
5.3 Adjusting Video Quality (Slow Motion Mode)	90
5.4 Applying a Color Filter (Slow Motion Mode)	91
5.5 Adjusting White Balance (Slow Motion Mode)	92
5.6 Adjusting ISO (Slow Motion Mode)	93

5.7 Adjusting Contrast (Slow Motion Mode)	94
5.8 Adjusting Exposure (Slow Motion Mode).....	95
5.9 Adjusting Metering Mode (Slow Motion Mode)	96
5.10 Adjusting LED Settings (Slow Motion Mode)	97
6.0 Self-Timer Photo Mode 	98
6.1 Self-Timer Settings (Photo Mode)	100
6.2 Adjusting Photo Resolution (Self-Timer Mode).....	101
6.3 Adjusting Photo Quality (Self-Timer Mode)	102
6.4 Applying a Color Filter (Self-Timer Mode)	103
6.5 Adjusting Auto White Balance (Self-Timer Mode).....	104
6.6 Adjusting ISO Setting (Self-Timer Mode).....	105
6.7 Adjusting Exposure (Self-Timer Mode).....	106
6.8 Adjusting Metering Mode (Self-Timer Mode).....	107
6.9 Adjusting LED Setting (Self-Timer Mode).....	108
7.0 Playback Mode 	109
7.1 Playback Mode Navigation and Screen Explanation	110
7.2 Photo Playback Screen Explanation	111
7.3 Video Playback Screen Explanation.....	111
7.4 Deleting Files.....	112
7.5 Accessing System Settings in Playback Mode	113
8.0 System Settings	114
8.1 Adjusting System Language	114
8.2 Setting Date and Time	115
8.3 Light Frequency	116
8.4 LED Indicator Light	117
8.5 System Sound	118
8.6 Power On/Off Sound.....	119
8.7 Auto Screen Off	120
8.8 Auto Power Off	121
8.9 Date & Time Stamp.....	122
8.10 Format Memory Card.....	122
8.11 Viewing Firmware Version	123
8.12 Flip Screen	124
8.13 Reset to Default	125
9.0 Technical Specifications	126

1.0 Introduction

About this Manual:

Congratulations on purchasing the Minolta MND33 Digital Camera!

The contents of this manual are subject to change without notice. Note that the example screens and product illustrations shown in this User's Guide may differ somewhat from the screens and configuration of the actual camera.

Copyright:

This manual contains proprietary information protected by copyright. All rights are reserved. No part of this manual may be reproduced by any mechanical, electronic or other means, in any form, without prior written permission of Elite Brands Inc. © 2025.

Federal Communications Commission Interference Statement:

This equipment has been tested and found to comply with the limits for a Class B digital device, pursuant to Part 15 of the FCC Rules. These limits are designed to provide reasonable protection against harmful interference in a residential installation. This equipment generates, uses and can radiate radio frequency energy and, if not installed and used in accordance with the instructions, may cause harmful interference to radio communications. However, there is no guarantee that interference will not occur in a particular installation. If this equipment does cause harmful interference to radio or television reception, which can be determined by turning the equipment off and on, the user is encouraged to try to correct the interference by one or more of the following measures:

- Reorient or relocate the receiving antenna.
- Increase the separation between the equipment and receiver.
- Connect the equipment into an outlet on a circuit different from that to which the receiver is connected.
- Consult the dealer or an experienced radio/TV technician for help.

Caution:

Any changes or modifications not expressly approved by the party responsible for compliance could void the user's authority to operate the equipment.

This device complies with Part 15 of the FCC Rules. Operation is subject to the following two conditions:

- (1) This device may not cause harmful interference and
- (2) This device must accept any interference received, including interference that may cause undesired operation.

RF Exposure Warning:

This equipment complies with the Federal Communications Commission (FCC) RF radiation exposure limits established for an uncontrolled environment. To ensure compliance with these exposure limits, it is essential to follow all installation and operation instructions. Additionally, this equipment should neither be co-located nor operated alongside any other antenna or transmitter unless specifically authorized. All users and installers must be provided with appropriate antenna installation guidelines and transmitter operating conditions to meet RF exposure requirements.

FCC Information:

This device adheres to Specific Absorption Rate (SAR) standards set by the FCC. The standard value is 1.6 W/kg, and the maximum measured value is 0.4 W/kg. SAR measures the rate of radio frequency energy absorption by the human body.

CE Mark Warning:

This device is classified as a **Class B product** under European Union (EU) regulations. In a residential environment, it may cause radio interference. In such cases, the user may be required to implement measures to reduce interference. This classification pertains to equipment used in both professional and residential environments, ensuring minimal interference with other electronic devices.

Camera Information & Guidelines for Safe Use:

The following instructions are designed to ensure the safety of both the user and the camera, while also extending the longevity and performance of the device.

General Handling Instructions:

- **Do Not Disassemble:** The camera contains precision components and delicate circuitry. Under no circumstances should users attempt to open, modify, or service the camera themselves. Unauthorized repair or modification may result in damage and will void any warranties.
- **Moisture & Temperature Exposure:** Avoid exposing the camera to **high humidity, extreme cold, or excessive heat.** Doing so can cause internal condensation, potentially damaging the electronics and optical components. When transitioning between environments with different temperatures (e.g., moving from a cold outdoor setting to a warm indoor environment), allow the camera to gradually adjust to avoid condensation.
- **Care with the Lens:** The camera lens is one of its most sensitive parts. Avoid direct contact with the lens, and do not apply pressure. Additionally, prolonged exposure to direct sunlight or bright light sources can degrade the lens coating and sensor, which may permanently damage image quality.

Cleaning Guidelines:

- **Cleaning Agents:** Avoid the use of **abrasive chemicals, cleaning solvents,** or harsh detergents when cleaning your camera. These substances can degrade the materials used in the camera body and lens. Instead, wipe the surface of the camera with a **soft, slightly damp cloth.** Be sure to avoid moisture from entering any openings, such as the microphone, speaker, or charging ports.
- **Lens Cleaning:** For cleaning the lens, use a specialized **lens cleaning cloth** or an air blower designed for camera equipment to remove dust and debris. Never use rough materials or force, as these may cause scratches.

Safety Considerations:

- **Flash & LED Usage:** Avoid using the camera's flash or LED light near individuals' eyes, especially in close proximity, as this could result in temporary visual impairment or discomfort.
- **Safe Usage While Mobile:** Operating the camera while walking, driving, or cycling is strongly discouraged, as it may divert attention and increase the risk of accidents or injury. Always ensure you're stationary and aware of your surroundings when using the device.
- **Handling Camera Straps:** Be particularly cautious when using the camera's strap. Never allow the strap to wrap around a child's neck, as this presents a serious choking hazard.
- **Impact & Shock Protection:** The camera is built to handle everyday use, but it remains a sensitive electronic device. Excessive shock, such as dropping the camera or subjecting it to heavy impact, could cause internal or external damage. Similarly, avoid placing pressure on the LCD screen, as this could lead to malfunction or permanent damage.

Battery Information:

The camera uses a rechargeable lithium-ion battery that requires proper care and handling for safety and longevity. Below are detailed guidelines for ensuring safe and effective use of the battery.

Installation & Replacement:

- **Proper Installation:** Always turn off the camera before installing or removing the battery. Ensure that the battery is correctly oriented as per the instructions. Incorrect insertion, such as placing the battery upside down, could result in damage to the camera, cause overheating, or even pose an explosion risk.
- **Battery Replacement:** Only use the provided battery or an officially recommended replacement. Use of incompatible batteries can damage the camera and void the warranty. The incorrect battery could also result in overheating, leakage, or fire hazards. Always follow local regulations for the safe disposal of old or damaged batteries.

Storage & Longevity:

- **Long-term Storage:** If you do not intend to use the camera for an extended period, download any important pictures, turn off the device, and remove the battery to prevent discharge or leakage. Store the battery separately in a **cool, dry place**.
- **Explosion Risk:** Replacing the battery with an incompatible type may pose a risk of explosion. Always handle with care and follow the manufacturer's instructions.

Safety Precautions:

- **Excessive Heat:** If you notice that the battery becomes excessively hot, emits smoke, or shows signs of discoloration, immediately discontinue use and safely remove it from the camera (if possible). Seek advice from a professional or your camera retailer.
- **Children's Safety:** Keep batteries out of reach of children. Ingesting batteries can cause serious health risks, such as internal burns, and in some cases, can be fatal.

USB Adapter Information:

The USB adapter provides the power necessary to charge the camera's battery. Follow these instructions to ensure proper function and safety:

Temperature Sensitivity:

- **Avoid Extreme Temperatures:** Keep the USB adapter away from high-temperature areas, such as heaters or direct sunlight, as this could cause the device to overheat, resulting in potential fire hazards. Similarly, do not use the adapter in moist environments, such as bathrooms, to prevent electric shock or equipment malfunction.

Usage Guidelines:

- **Safe Handling:** Never attempt to disassemble, modify, or tamper with the USB adapter. If the adapter sustains damage or malfunctions, discontinue use and seek a replacement.
- **Condensation Risks:** Avoid using the USB adapter immediately after moving from a cold to a warm environment, as sudden temperature changes may cause internal condensation. Wait until the device reaches room temperature to avoid short circuits.
- **Wet Hands Warning:** Never touch the USB plug or the electrical components with wet hands, as this could result in a dangerous electric shock.

Power Source Compatibility:

- **Avoid Converters:** Do not use travel voltage converters or AC/DC power inverters with the adapter, as these may overload or damage the camera. Instead, only use certified power sources compatible with the voltage requirements of your region.

Precautions for Specific Use Cases

Condensation & Sudden Temperature Changes:

Moving between environments with significantly different temperatures, such as entering a heated building from the cold outdoors, can cause condensation to form inside the camera. To avoid this, place the camera inside a plastic bag or carrying case before making such transitions. This will help reduce the risk of moisture accumulating inside the camera, which can cause damage to electronic components.

Handling Strong Magnetic Fields:

Strong electromagnetic fields, such as those generated by power stations or medical equipment, may interfere with your camera's internal circuits, leading to malfunction or data loss. Avoid storing or operating your camera near devices that emit strong electromagnetic radiation.

Exposure to Strong Light Sources:

Extended exposure of the lens to strong light sources, such as direct sunlight, could degrade the camera sensor and reduce image quality. If the camera is frequently exposed to strong light, it may cause permanent white blurring on your photographs. Ensure the camera is stored in a safe, shaded area when not in use.

Powering Off & Memory Card Guidelines

Safely Power Off:

Always turn off the camera before removing the battery or memory card. Removing the battery while the camera is still powered on or actively writing data may result in data loss or corruption. Additionally, this may cause damage to both the memory card and the internal circuitry.

LCD Screen Guidelines

Screen Specifications:

The LCD screen is manufactured with high precision and features a 99.99% effective pixel rate. Although this is a high-quality screen, you may occasionally observe pixels that appear always on (lit) or off (black). This is a normal occurrence in LCD technology and does not affect the camera's functionality or the images you capture.

Visibility in Bright Light:

Under bright lighting conditions, images displayed on the LCD may be difficult to see. For optimal viewing, use the camera in shaded or indoor environments.

Handle with Care:

Avoid placing undue pressure on the LCD screen, as this could lead to permanent damage or malfunction. If the screen cracks or becomes unresponsive, seek professional repair services.

Charging the Battery

Charging Conditions:

To ensure optimal battery performance and longevity, it's recommended to charge the battery indoors at a temperature between **5°C (41°F) and 35°C (95°F)**. Charging the battery when it's too cold or too hot can reduce its efficiency and lifespan.

Battery Temperature:

If the battery becomes excessively hot during charging, immediately disconnect it from the power source. This could indicate a malfunction, which may require professional assistance. The battery may feel warm during and after extended use—this is normal and typically poses no risk.

Avoid Overcharging:

Once the battery reaches full charge, unplug the charger. Continuous charging after the battery is full can degrade performance over time.

Storage Recommendations:

If you do not plan to use your camera for an extended period, follow these guidelines to ensure that it remains in optimal condition:

- **Battery Removal:** Always remove the battery from the camera if it will be stored for several weeks or longer. This prevents potential battery leakage and reduces the risk of damage to the internal components.
- **Ideal Storage Conditions:** Store the camera in a cool, dry environment where the temperature remains **between -10°C (14°F) and 50°C (122°F)**. Avoid environments with high humidity (above 60%), as excessive moisture may cause internal corrosion or mold growth on the lens.

Recycling and Disposal of Batteries

When your battery no longer holds a charge, it should be recycled properly. Used batteries are classified as hazardous waste due to their chemical contents and should not be disposed of with regular household trash. Always consult local regulations on proper recycling or disposal methods for electronic waste and batteries.

- The battery will not charge at battery temperature below 5°C (41°F) or above 55°C (131°F).
- When the battery is between 45°C (113°F) - 55°C (131°F), the chargeable capacity may decrease.
- Do not continue charging once the battery is fully charged as this will result in reduce battery performance.
- The battery temperature may increase during charging. However, this is not a malfunction.
- Note that the battery may become hot after use.
- Do not use the battery at ambient temperatures below 0°C (32°F) or above 40°C (104°F) as this could cause damage or malfunction.
- If you notice any abnormalities such as excessive heat, smoke, or an unusual smell coming from the battery, immediately discontinue use and consult your retailer.

- After removing the battery from the camera or optional battery charger, put the battery in a plastic bag, etc. in order to insulate it.

Using the Battery When Cold:

On cold days, the capacity of batteries tends to decrease. If an exhausted battery is used at a low temperature, the camera may not turn on. Keep spare batteries in a warm place and exchange as necessary. Once warmed, a cold battery may recover some of its charge.

Recycling Used Batteries:

Replace the battery when it no longer holds a charge. Used batteries are a valuable resource and should be recycled in accordance with local regulations.

Storage:

If you do not intend to use the camera for an extended period, remove the battery and avoid storing the camera in any of the following types of locations:

- Places that are poorly ventilated or subject to humidity of over 60%
- Place exposed to temperatures above 50°C (122°F) or below -10°C (14°F).

Getting Started

1.1 Buttons and Operation Overview

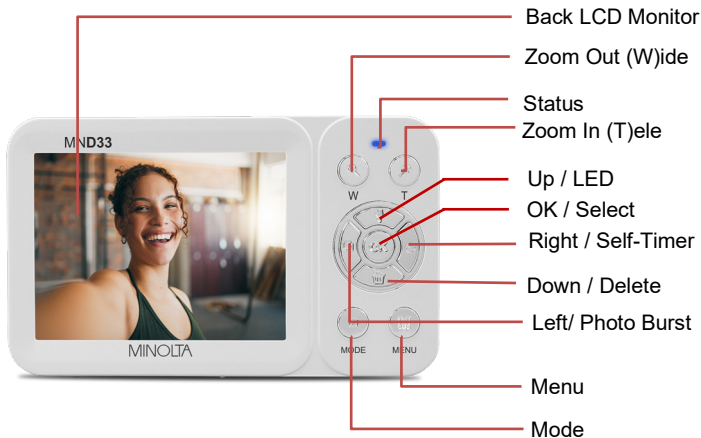

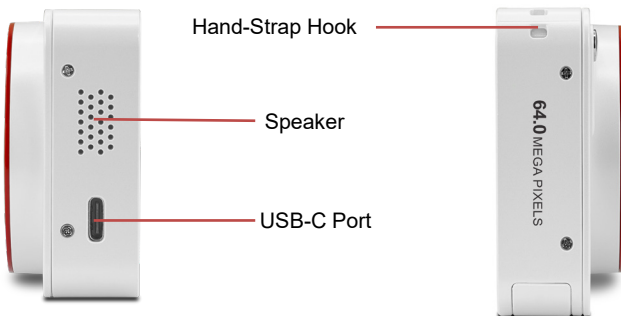

1.2 Buttons and Operation Overview Explained

Name:	Function:
Front LCD Monitor	The secondary LCD monitor to display media and live view
LED Flash/ Video Light	Photo Mode: White LED Flash Video Mode: Fill-in white LED video light for additional lighting
Lens	Front objective lens for photo and video capture
Back LCD Monitor	The main LCD monitor to display media and live view
Zoom Out (W)ide	Digital Zoom Out (Wide) 1-18x
Status LED	Fast Blinking Blue: Working Solid Blue: Powered On/Standby Slow Blinking Blue: Recording Solid Red: Battery is charging
Zoom In (T)ele	Digital Zoom In (Tele) 1-18X
Up/LED Flash	In Photo Mode: Off/ On/ Auto/ Force In Video Mode: Off/ Auto/ Force
OK/Select	In Settings: Button to confirm a selection In Video Playback: Button to play or pause a video

Right/Self-Timer	In Settings: Button to move Right when navigating menus In Self-Timer: Button to cycle through Self-Timer options
Down/Delete	In Settings: Button to move Down when navigating menus In Playback: Button to delete last photo/video captured
Left/Photo Burst	In Settings: Button to move Left when navigating In Photo Burst: Button to cycle through Photo Burst options
Menu	Button to enter the settings menu in each mode
Mode	Button to switch between Photo and Video functions
Power	Button to power the camera On or Off
Shutter/Record	In Photo Mode: Button to capture a photo In Video Mode: Button to start or stop recording video
Speaker	Built-in speaker plays button-press sounds and other video playback sounds
USB-C Port	Port for charging battery, transferring photos to a PC, or using your camera as a PC Camera
Battery/Memory Card Door	Door to protect the battery compartment and memory card slot
Tripod Mount	Mount port for attaching to a tripod nut (3/8")

1.3 Camera Features and Operation

In addition to basic photo and video capture, the Minolta MND33 offers a variety of shooting modes to suit different situations. This section describes how to make the most of your camera's key features. Along with the explanation of its operations, it will enable you to enjoy your camera to the fullest.

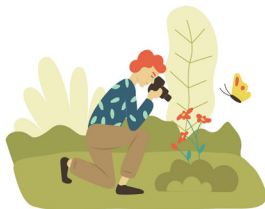

First Use

1.4 Operating the Battery Door

Refer to the below diagram to locate the battery door and its locking latch.

1. **Unlock the Battery Door**

Slide the battery door latch to the left, away from the center of the camera. This will release the lock.

2. **Open the Battery Door**

Once unlocked, the battery door will flip open to the right, giving you access to the battery compartment.



1.5 Installing the Battery

Refer to the diagram below to check the correct battery orientation before inserting.



- 1. Align the Battery**
Hold the lithium-ion battery so the metal contacts face inward toward the contacts inside the battery compartment.
- 2. Insert the Battery**
Gently slide the battery into the compartment until it is fully seated. The locking latch will secure it once inserted correctly.
- 3. Verify Installation**
The camera will only power on if the battery contacts align properly with the contacts inside the compartment. If the camera does not turn on, remove the battery, check its orientation, and insert it again.

NOTE: The battery can only be inserted in one direction. Do not force it.

1.5 Installing the Memory Card

Refer to the diagram below to confirm the correct memory card orientation before inserting.

1. **Align the Memory Card**

Hold the memory card so the metal contacts face the correct direction as shown in the diagram.

2. **Insert the Memory Card**

Gently slide the card into the slot located inside the battery compartment. Push it in until you hear or feel an audible click, indicating that it is securely seated.

3. **Verify Installation**

The card only fits one way. Do not force it. If it does not slide in smoothly, remove it, check its orientation, and try again.

4. **Remove the Memory Card**

To remove the card, press it in gently. It will eject back out for easy removal.



NOTE:

Format the memory card before using the camera. **Caution:** This will erase all data on the card.

Do not remove or insert the memory card while recording. This may damage the card or cause data loss.

Use a memory card with a speed rating of Class 10 or higher.

The maximum supported microSD card capacity is 256 GB.

1.6 Charging the Battery

Refer to the below diagram to locate the camera's USB-C port and see how to connect the charging cable.

1. **Connect the USB-C Cable to the Camera**
Insert the smaller end of the included USB-C cable into the camera's USB-C port.
2. **Connect the USB-A End to the AC Adapter**
Plug the larger USB-A end of the cable into the included AC adapter.
3. **Plug the Adapter into a Power Outlet**
Insert the AC adapter into a standard power outlet to begin charging.
4. **Check the Charging Indicator**
While charging, the LED indicator will light up solid red. The light will turn off when charging is complete.

NOTE: You may use the camera normally while it is charging.

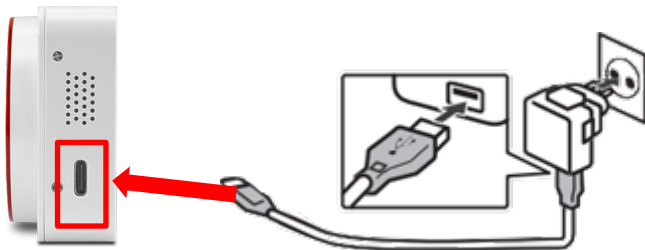

1.7 Powering the Camera On and Off

Refer to the below diagram to locate the **POWER** button.

1. **Turn the Camera On**

Press and hold the **POWER** button for about 3 seconds. The screen will turn on when the camera starts up.

2. **Turn the Camera Off**

When you are finished, press and hold the **POWER** button again for about 3 seconds. The camera will power down.

3. **Low Battery Warning**

If the battery is low, a “Low Battery” message will appear on the screen. After a few seconds, the camera will automatically shut down to prevent file corruption or data loss.



1.8 Connecting to a Computer

You can connect your camera to a computer to transfer photos and videos for viewing or editing, or to use the camera as a PC Camera.

1. **Locate the USB-C Port**

Find the USB-C port on the side of the camera.

2. **Connect the Cable to the Camera**

Insert the smaller end of the USB-C cable into the camera's USB-C port.

3. **Connect the Cable to the Computer**

Plug the larger USB-A end of the cable into an available USB port on your computer.

NOTE: Plug the camera directly into an integrated USB port on the computer. Do not use a USB hub or extension. Once connected, the camera will display connection options on the screen.

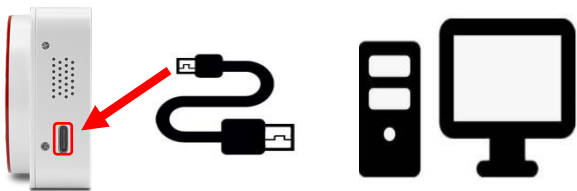

1.9 Selecting the USB Connection Mode

Refer to the diagram below to identify the on-screen connection mode options. Once the camera is connected to the computer and powered on, two or more connection modes will appear on the screen.

Use the **UP** or **DOWN** buttons to select your desired mode, then press the **OK** button to enter that mode.

- **MSDC (Mass Storage Mode)**
Allows you to access the files on the inserted memory card via your computer.
- **PC Camera Mode**
Allows the camera to function as a PC webcam.
- **Charging Mode**
Allows the camera to function normally while charging the battery.

NOTE: When using the camera in PC Camera Mode, video recording is disabled.

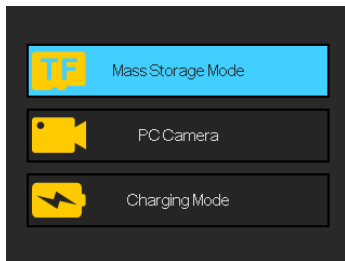

1.10 Transferring Media to PC

Once you've connected the USB-C cable to your computer, powered on your camera, and entered **MSDC / Mass Storage Mode** on your camera, your computer should recognize it immediately.

1. You should see the **AutoPlay** window pop up. Click the **AutoPlay** box in the bottom-right corner of your computer screen.
2. Select **Open folder to view files**. This will open the File Explorer. You may need to scroll down to find this option.

Alternatively, you can open this folder manually. Right click the Start menu and click **File Explorer**. Click **This PC** listed on the left panel, and then find the drive of your memory card.

3. Click **DCIM**. You may see the photos immediately. In most cases, photos will be in folder labeled DCIM (Digital Camera Photos), or in another subfolder with the DCIM folder.
4. Select the photos you want to transfer. You can transfer individual photos, or press **CTRL + A** on your keyboard to select all the photos in the folder. To select multiple photos, hold **CTRL** and click each photo.

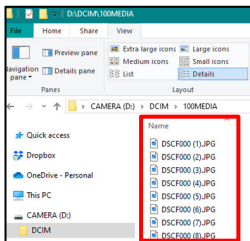
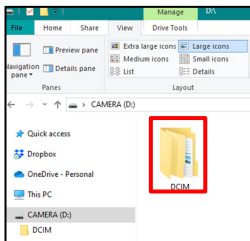
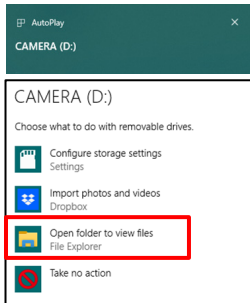

5. Drag the pictures to a new location on your PC. You can drag the photos into the **Pictures** folder, or you can create a new folder.

The amount of time it takes to transfer will depend on the number of files being copied, the files sizes, and your computer's specifications.

If you want to delete the photos from your camera's memory card, wait for the files to finish transferring to your computer. Return to the memory card's folder and press **CTRL + A** to select all the photos. Right-click the photos, then click **Delete**.

1.11 Camera Mode Settings Menu Explanation

The settings menu changes based on the camera's current shooting mode. For example:

- In **Photo Mode**, only settings relevant to photo capture will be displayed.
- In **Video Mode**, only settings relevant to video recording will be displayed.

Follow these steps to open and navigate the settings menu:

1. **Open the Menu**
Press the **MENU** button.
2. **Navigate**
Use the **UP**, **DOWN**, **LEFT**, and **RIGHT** buttons to move through the menu.
3. **Confirm a Selection**
Press the **OK** button to confirm your choice.
4. **Exit the Menu**
Press the **MENU** button again to close the menu quickly.

This User Manual explains each shooting mode first, followed by the settings menu for that specific mode.

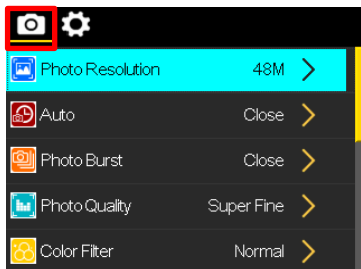

1.12 Using the LED Flash / Video Light

The LED light helps improve exposure in darker scenes and can also be used as a video light. The optimal range for the LED light is between 8 and 16 ft.

To enable or adjust the LED Flash or Video Light settings, press the **UP / FLASH** button. Each press will cycle through the available flash and light options. Select the desired setting before capturing your photo or recording video.



Photo Shooting Modes

On ⚡

The LED light stays on continuously while taking photos.

Auto ⚡

The flash activates automatically when the camera detects low light in the scene.

Force ⌘

The flash stays on for every shot, regardless of lighting conditions.

Off ✖

The flash remains off, and no supplemental light is used.



Photo Mode – Flash Icon

Video Shooting Modes

On ⚡

The LED light stays on continuously while taking photos.

Auto ⚡

The flash activates automatically when the camera detects low light in the scene.

Force ⌘

The flash stays on for every shot, regardless of lighting conditions.

Off ✖

The flash remains off, and no supplemental light is used.



Video Mode – LED Light Icon

1.13 Shooting Modes

The MND33 offers several advanced shooting modes, each designed for different types of photography.

To change modes, press the **MODE** button and use the **LEFT**, **RIGHT**, **UP**, or **DOWN** buttons to scroll through the available options.

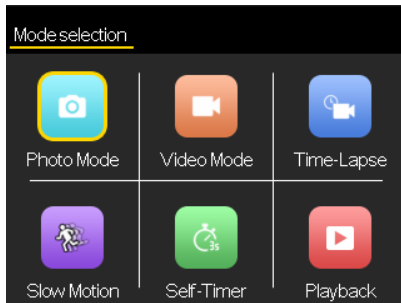

Refer to the sections below for a breakdown of each shooting mode and its specific features.

1.13.1 Photo Mode

Photo mode is a fully automatic photo capture mode where the camera makes all the setting decisions for you. It analyzes the scene and applies the best settings to capture a clear and well-balanced photo. Using this mode will generally produce great results without any manual adjustments.



1.13.2 Video Mode 

Video mode is the standard setting for recording videos. In this mode, one video file is created for each recording session. Press the SHUTTER button to start recording, and press the SHUTTER button again to stop.

During recording, a time counter on the screen will increase as the video progresses. When not recording, the screen will display the remaining available recording time, which is based on the selected video resolution. Higher resolution settings use more space on the memory card, reducing the total recording time available. Before recording, you can choose your preferred video resolution in the settings menu.



1.13.3 Time Lapse (Video)

Mode 

Time lapse mode captures a series of images at set intervals and automatically compiles them into a video that plays back at a much faster speed. This mode is ideal for recording slow-moving scenes such as sunsets, drifting clouds, or gradual changes in lighting throughout the day.



When played back, the resulting video condenses hours of real-time movement into just a few seconds, allowing you to view long events quickly and smoothly.

Time Lapse Mode uses a simplified setup controlled by a single **Duration** setting. The Duration determines how long the camera will record frames for the time-lapse sequence. Once you select a duration, the camera automatically begins recording and stops when the chosen time has elapsed.

The interval between frames and playback speed are managed internally by the camera, so you only need to choose how long you want to capture.

Example: If you select a Duration of 30 seconds, the camera will record frames over 30 seconds and then automatically create a time-lapse video that plays back in a much shorter time, based on the internal frame rate.

1.13.4 Slow-Motion Mode 

Slow-motion mode allows you to record videos that play back in slow motion. The camera records at a higher frame rate, which results in smoother, slower playback.

The capture quality and playback duration are determined by the Resolution setting you choose.



Example: If you select the 1080P 60FPS slow-motion setting, the video will be recorded in 1080P resolution at 60 frames per second and will play back at half the speed of real time. A 5-second recording at this setting will result in a 10-second slow-motion video.

1.13.5 Self-Timer Photo

Mode 

Self-timer mode allows you to set a countdown timer so the camera automatically takes a photo after a chosen delay. This feature is useful for group photos or when you want to avoid camera shake by not pressing the button during the shot.



Example: If you select the 2-second self-timer setting, the camera will capture a photo 2 seconds after you press the **SHUTTER** button.

1.13.6 Playback Mode 

Playback mode allows you to review all the photos and videos stored on your camera.

1. **Enter Playback Mode**

Press the **MODE** button, then use the **LEFT**, **RIGHT**, **UP**, or **DOWN** buttons to navigate to Playback Mode.

2. **View and Adjust Media**

Press the **OK** button to enter full photo view, where you can zoom in, play videos, or adjust playback settings.

3. **Exit Playback Mode**

Press the **MODE** button again at any time to return to shooting mode.



1.14 Using the Front LCD Monitor

The MND33 features a secondary LCD screen on the front of the camera, making it easy to capture creative selfies or front-facing shots without extra equipment. The front LCD can be activated in any shooting mode.

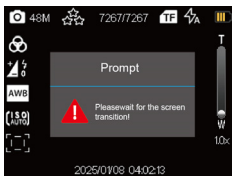

1. Activate the Front LCD

Press and hold the **OK** button for 2 seconds. The front LCD screen will turn on, and you can use the camera normally to take selfies or other shots.

2. Switch Back to the Main LCD

Press and hold the **OK** button again to return to shooting with the main LCD screen.

NOTE: Only one LCD screen can be active at a time. The front LCD does not allow you to navigate menus or change shooting modes. Make sure to confirm your desired shooting mode before switching to the front LCD screen. To change modes, hold down the **OK** button to switch back to the main LCD.

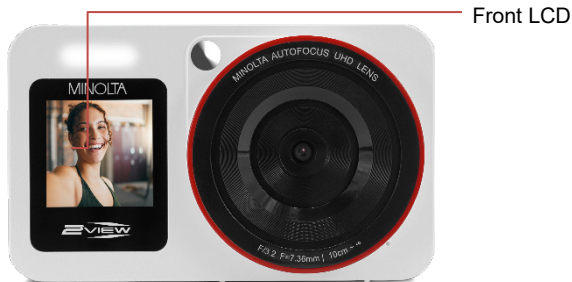

1.15 Using Digital Zoom

The MND33 is equipped with an autofocus lens and an 18× digital zoom feature. Digital zoom electronically enlarges your photo by cropping and magnifying the center of the image.

To use the zoom function:

- Push and hold the **T**(ele) button to zoom in closer to the subject.
- Push and hold the **W**(ide) button to zoom out and capture a wider view.





Video Mode – Zoom Bar

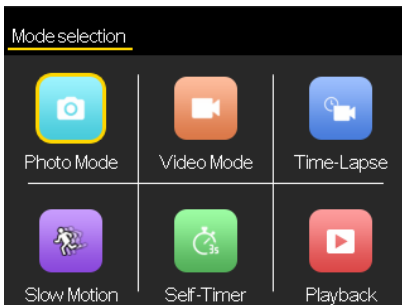

Photo Mode – Zoom Bar

2.0 Photo Mode

Photo Mode allows the camera to automatically select the best settings for capturing clear still images. This is the default mode for general photo-taking.

- The camera handles exposure, white balance, and focus automatically.
- Ideal for everyday photography without needing to adjust advanced settings.



Follow these steps to access Photo Mode:

1. **Power On the Camera**
Press and hold the **POWER** button until the screen turns on.
2. **Open Shooting Mode Navigation**
Press the **MODE** button to enter the Shooting Mode selection screen.
3. **Select Photo Mode**
Use the **LEFT**, **RIGHT**, **UP**, or **DOWN** buttons to scroll through the available modes.
4. **Confirm Selection**
When Photo Mode is highlighted, press the **OK** button to confirm.
5. **Begin Shooting**
The camera will switch to *Photo Mode* and be ready to capture images.

2.1 Photo Capture Screen Icons

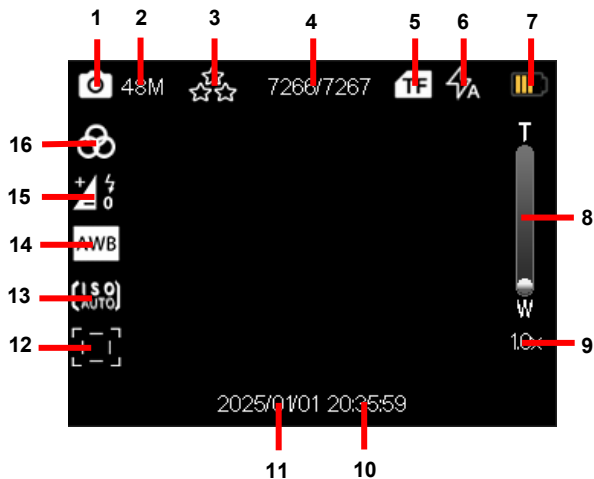

	Function:
1	Photo Capture Mode
2	Current Photo Resolution setting
3	Photo Quality status
4	Current available photo count
5	Memory card installation status
6	Flash status: Automatic / Off / Forced / Always On
7	Battery charging status or battery level
8	Zoom Bar (1.0-18X)
9	Current zoom level status
10	Time Stamp
11	Date Stamp
12	Current Metering Mode: Average / Center / Spot / Matrix
13	Current ISO sensitivity setting
14	Current White Balance setting
15	Current Exposure Compensation value
16	Current Color Filter status

2.2 Capturing a Photo

The MND33 offers several photo shooting modes, each with unique features. Regardless of which mode you select, capturing a photo follows the same basic steps.

After choosing your photo shooting mode, hold the camera steady and make sure your fingers do not block the flash or lens.

- Point the lens at the subject you want to photograph. Use the LCD monitor to frame your shot.
- Use the **ZOOM** buttons to zoom in **T**(ele) for a closer view or zoom out **W**(ide) to include more of the scene.
- Press the **SHUTTER** button halfway to focus on the subject. When the focus frame turns green, the subject is in focus.
- Press the **SHUTTER** button all the way down to take the photo.

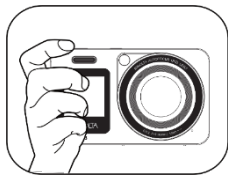

When you half press the **SHUTTER** button, the camera will attempt to focus on your subject. If focus is successful, green rectangles will appear on the screen to indicate a clear focus. You can then fully press the **SHUTTER** button to capture the image. If red rectangles appear, the camera could not focus properly. Adjust your distance slightly and half-press the **SHUTTER** button again until focus is achieved.



2.3 Photo Mode Settings

The settings menu adapts based on the currently selected shooting mode.

To open the settings menu, press the **MENU** button.

Use the **UP** and **DOWN** buttons to navigate menu options, and press the **OK** button to confirm a selection.

To cycle between submenus, continue using the **UP** and **DOWN** buttons. To exit the settings menu quickly, press the **MENU** button again.

NOTE: To access the general system settings, use the **LEFT** or **RIGHT** buttons to switch menus.

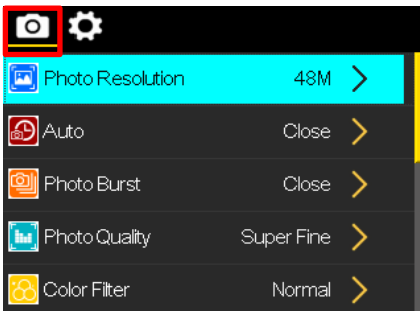

2.4 Adjusting Photo Resolution

This setting controls the detail level of each photo by adjusting its resolution.

- Higher resolutions (*64MP, 48MP*) produce sharper images but use more space on the memory card.
- Lower resolutions (*24MP, 8MP*) use less space on the memory card but reduce image detail.

Follow these steps to adjust the resolution:

1. **Open the Menu**

Press the **MENU** button while in Photo Mode.

2. **Select Photo Resolution**

Use the **UP** or **DOWN** buttons to highlight *Photo Resolution*, then press the **OK** button.

3. **Choose a Resolution**

Select from 64 Mega Pixels, 48 Mega Pixels, 24 Mega Pixels, or 8 Mega Pixels.

4. **Confirm Your Selection**

Press the **OK** button to confirm.

5. **Exit the Menu**

Press the **MENU** button to return to shooting mode.

2.5 Interval Shooting

Interval Shooting automatically captures a photo every few seconds until you stop it. This feature is useful for creating a sequence of photos over time, such as moving clouds, a busy street, or a sunset.

- Off – Disables interval shooting.
- 3 Seconds – Captures photos frequently, good for fast-changing subjects.
- 10 Seconds – Balanced option for moderate changes over time.
- 15 Seconds – Captures less often, best for slow-moving subjects or longer sessions.

Note: Interval Shooting can quickly use more space on the memory card, since each shot is saved as a separate photo.

Follow these steps to adjust Interval Shooting:

1. **Open the Menu**
Press the **MENU** button to access the settings.
2. **Select Interval Shooting**
Use the **UP** or **DOWN** buttons to scroll to *Interval Shooting*.
Press the **OK** button to confirm.
3. **Choose Interval Time**
Use the **UP** or **DOWN** buttons to select *Off, 3 sec, 10 sec, or 15 sec*.
Press the **OK** button to confirm your choice.
4. **Start Interval Shooting**
Press the **SHUTTER** button once.
The camera will automatically take a photo at the set interval until you press the **SHUTTER** button again.
5. **Exit**
Press the **MENU** button to return to shooting mode.

2.6 Photo Burst Setting

This setting allows the camera to capture multiple photos in rapid succession with a single press of the shutter button.

- Use higher burst settings (e.g., 10 Photos) to improve your chances of capturing fast action.
- The LED flash is automatically disabled while Photo Burst is active.

Follow these steps to adjust the Photo Burst setting:

1. **Open the Menu**
Press the **MENU** button while in Photo Mode.
2. **Select Photo Burst**
Use the **UP** or **DOWN** buttons to highlight *Photo Burst*, then press the **OK** button.
3. **Choose a Burst Option**
Select from *3 Photos*, *5 Photos*, or *10 Photos*.
4. **Confirm Your Selection**
Press the **OK** button to confirm.
5. **Exit the Menu**
Press the **MENU** button to return to shooting mode.

NOTE: You can also access Photo Burst settings quickly by pressing the **LEFT** button in Photo Mode.

2.7 Adjusting Photo Quality

This setting controls how much detail is preserved in each photo by adjusting the compression level used when saving the image.

- *Super Fine* offers the highest image quality with the least compression but uses the most memory card space.
- *Fine* provides a good balance between quality and file size.
- *Normal* compresses photos more to save space, which may reduce detail.

Follow these steps to adjust the photo quality:

1. **Open the Menu**
Press the **MENU** button while in Photo Mode.
2. **Select Photo Quality**
Use the **UP** or **DOWN** buttons to highlight *Photo Quality*, then press the **OK** button.
3. **Choose a Quality Option**
Select from *Normal*, *Fine*, or *Super Fine*.
4. **Confirm Your Selection**
Press the **OK** button to confirm.
5. **Exit the Menu**
Press the **MENU** button to return to shooting mode.

2.8 Applying Color Filter

This setting allows you to apply a creative effect to your photos before they are taken. Filters change the visual style of the image by altering its color, contrast, or overall mood.

NOTE: Once a filter is applied and the photo is captured, the effect is permanent and cannot be removed.

Follow these steps to apply a color filter:

1. **Open the Menu**
Press the **MENU** button while in Photo Mode.
2. **Select Color Filter**
Use the **UP** or **DOWN** buttons to highlight *Color Filter*, then press the **OK** button.
3. **Choose a Filter**
Select from *Normal, Black & White, Negative, Lomo, Dogeye, High Saturation, Red, Green, Blue, or Retro*.
4. **Confirm Your Selection**
Press the **OK** button to confirm.
5. **Exit the Menu**
Press the **MENU** button to return to shooting mode.

2.9 Adjusting White Balance

This setting adjusts the color tone of your photos to match the lighting conditions, making images appear more natural. Different types of light can make photos look too warm or too cool if not corrected.

Tip: Use Auto for most situations, or manually select a mode based on your lighting.

Follow these steps to adjust White Balance:

1. **Open the Menu**
Press the **MENU** button while in Photo Mode.
2. **Select White Balance**
Use the **UP** or **DOWN** buttons to highlight *White Balance*, then press the **OK** button.
3. **Choose a White Balance Option**
Select from *Auto*, *Sunny*, *Cloudy*, *Incandescent*, or *Fluorescent*.
4. **Confirm Your Selection**
Press the **OK** button to confirm.
5. **Exit the Menu**
Press the **MENU** button to return to shooting mode.

2.10 Adjusting ISO Setting

ISO controls the camera's sensitivity to light. This setting helps you maintain proper exposure when recording in different lighting conditions.

- Use lower ISO values (e.g., 100–400) in bright settings for sharper, cleaner video.
- Use higher ISO values (e.g., 1600–6400) in low-light settings, but expect more grain or visual noise.

Tip: Use Auto to let the camera select the best ISO for the scene.

Follow these steps to adjust ISO:

1. **Open the Menu**
Press the **MENU** button while in Photo Mode.
2. **Select ISO**
Use the **UP** or **DOWN** buttons to highlight *ISO*, then press the **OK** button.
3. **Choose an ISO Setting**
Select from *Auto*, *100*, *200*, *400*, *800*, *1600*, *3200*, or *6400*.
4. **Confirm Your Selection**
Press the **OK** button to confirm.
5. **Exit the Menu**
Press the **MENU** button to return to shooting mode.

2.11 Adjusting Exposure Value

This setting adjusts the overall brightness of your photo by increasing or decreasing the exposure value.

- Use negative values (-1 to -3) to darken overexposed scenes.
- Use positive values ($+1$ to $+3$) to brighten underexposed scenes.
- Set to 0 for standard exposure.

Follow these steps to adjust the Exposure:

1. **Open the Menu**
Press the **MENU** button while in Photo Mode.
2. **Select Exposure**
Use the **UP** or **DOWN** buttons to highlight *Exposure*, then press the **OK** button.
3. **Choose an Exposure Value**
Select from -3 , -2 , -1 , 0 , $+1$, $+2$, or $+3$.
4. **Confirm Your Selection**
Press the **OK** button to confirm.
5. **Exit the Menu**
Press the **MENU** button to return to shooting mode.

2.12 Adjusting Metering Mode

Metering determines how the camera evaluates the lighting in a scene to set exposure. This setting adjusts how much of the frame is used to calculate brightness.

- *Spot Metering* measures light in a small focus area—ideal for backlit subjects.
- *Center Metering* evaluates the center of the frame, useful for off-center subjects.
- *Average* and *Matrix Metering* consider the whole frame for balanced exposure.

Follow these steps to adjust Metering Mode:

1. **Open the Menu**
Press the **MENU** button while in Photo Mode.
2. **Select Metering Mode**
Use the **UP** or **DOWN** buttons to highlight *Metering Mode*, then press the **OK** button.
3. **Choose a Metering Option**
Select from *Average Metering*, *Center Metering*, *Spot Metering*, or *Matrix Metering*.
4. **Confirm Your Selection**
Press the **OK** button to confirm.
5. **Exit the Menu**
Press the **MENU** button to return to shooting mode.

2.13 Adjusting LED Settings

This setting controls how the camera's LED light behaves during photo shooting. It helps illuminate scenes in low-light conditions.

- *On* – The LED stays on continuously.
- *Auto* – The LED activates automatically based on lighting conditions.
- *Force* – The LED remains on regardless of lighting conditions.
- *Off* – The LED remains off at all times.

Follow these steps to adjust the LED light setting:

1. **Open the Menu**
Press the **MENU** button while in Photo Mode.
2. **Select LED**
Use the **UP** or **DOWN** buttons to highlight *LED*, then press the **OK** button.
3. **Choose an LED Mode**
Select from *Off*, *On*, *Force*, or *Auto*.
4. **Confirm Your Selection**
Press the **OK** button to confirm.
5. **Exit the Menu**
Press the **MENU** button to return to shooting mode.

2.14 Adjusting Shutter Sound

This setting enables or disables the shutter sound that plays when a photo is captured.

- *On* – A shutter sound will play with each photo taken.
- *Off* – No sound will play during photo capture.

Follow these steps to adjust the shutter sound:

1. **Open the Menu**
Press the **MENU** button while in Photo Mode.
2. **Select Shutter Sound**
Use the **UP** or **DOWN** buttons to highlight *Shutter Sound*, then press the **OK** button.
3. **Choose a Setting**
Select *On* or *Off*. A checkmark will appear next to the active setting.
4. **Confirm Your Selection**
Press the **OK** button to confirm.
5. **Exit the Menu**
Press the **MENU** button to return to shooting mode.

3.0 Video Mode

Video Mode allows the camera to automatically select the best settings for capturing clear video. This is the default mode for standard video recording and is ideal for general-purpose shooting.

- The camera selects exposure, white balance, and focus automatically.
- Only one video file is recorded per full press of the **SHUTTER** button.

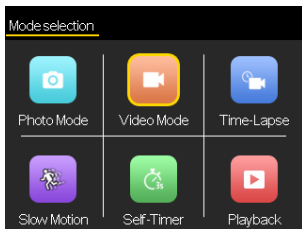

Follow these steps to record a video:

1. **Enter Video Mode**
Press the **MODE** button to access Shooting Mode navigation. Use the **LEFT**, **RIGHT**, **UP**, or **DOWN** buttons to highlight *Video Mode*, then press the **OK** button.
2. **Frame Your Subject**
Point the lens at your subject and use the LCD monitor to frame your shot.
3. **Adjust the Zoom**
Press the **T** button to zoom in or the **W** button to zoom out.
4. **Focus the Camera**
Half-press the **SHUTTER** button. The camera will attempt to focus automatically:
 - Green rectangles indicate a successful focus.
 - Red rectangles indicate focus failure—try adjusting your distance from the subject.
5. **Start Recording**
Once the subject is in focus, fully press the **SHUTTER** button to begin recording.
6. **Stop Recording**
Press the **SHUTTER** button again to stop. A new video file is created each time recording is stopped.

3.1 Video Capture Screen Icons

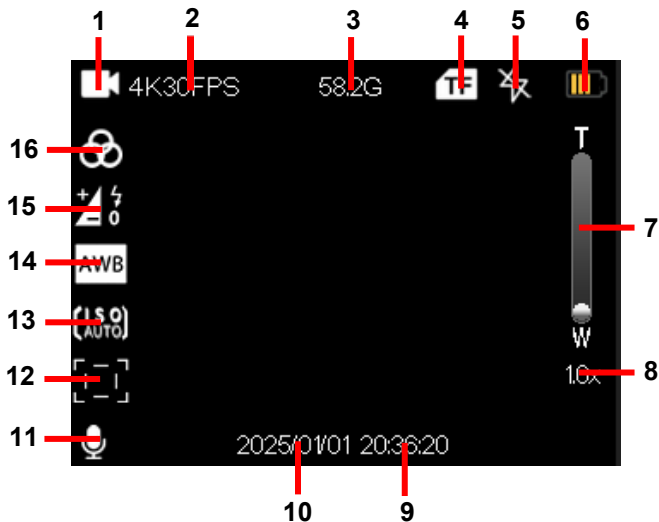

	Function:
1	Video Capture Mode
2	Current Video Resolution setting
3	Memory Card Storage status
4	Memory Card installation status
5	Current Flash Status: Off/ On/ Force/ Auto
6	Battery charging status or battery level
7	Zoom Bar (1.0-18X)
8	Current zoom level setting
9	Time Stamp
10	Date Stamp
11	Microphone settings
12	Current Metering Mode: Average, Center, Spot, Matrix
13	Current ISO setting
14	Current White Balance setting
15	Current Exposure Compensation value
16	Current Color Filter setting

3.2 Capturing a Video

The MND33 offers several video recording modes, each with unique features. Regardless of the selected mode, recording a video follows the same basic steps.

After selecting your video mode, hold the camera steady and make sure your fingers do not block the flash or lens.

- Point the lens at the subject you want to record. Use the LCD monitor to frame your shot.
- Use the **ZOOM** buttons to zoom in **T**(ele) for a closer view or zoom out **W**(ide) to include more of the scene.
- Press the **SHUTTER** button halfway to focus on your subject. When the focus frame turns green, the subject is in focus.
- Press the **SHUTTER** button all the way down to begin recording.

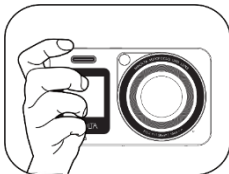

When you half press the **SHUTTER** button, the lens will attempt to focus on your subject. If focus is successful, green rectangles will appear on the screen to confirm a clear focus. If red rectangles appear, the camera could not focus properly. Adjust your distance slightly and half-press the **SHUTTER** button again to refocus before recording.



You can also refocus during an active recording by half-pressing the **SHUTTER** button again. The lens will attempt to focus, and green rectangles will appear if focus is clear.

Stop / SHUTTER

To stop recording, press the **SHUTTER** button again. Each time you stop, the camera saves the video as a separate file.



3.3 Video Mode Settings

The settings menu in Video Mode allows you to adjust recording options such as resolution, frame rate, and other video-specific features. The options available will depend on the current shooting mode.

- Only video-related settings will appear while in Video Mode.
- Use the **LEFT** or **RIGHT** buttons to switch to system or photo settings if needed.

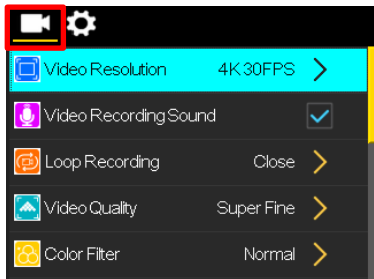

Follow these steps to access and navigate the settings:

1. **Open the Menu**
While in Video Mode, press the **MENU** button.
2. **Navigate Between Menus**
Use the **LEFT** or **RIGHT** buttons to switch between the different settings categories.
3. **Scroll Through Menu Options**
Use the **UP** or **DOWN** buttons to highlight an option.
4. **Confirm a Selection**
Press the **OK** button to enter a submenu or apply a setting.
5. **Exit the Menu**
Press the **MENU** button again to return to Video Mode.

3.4 Adjusting Video Resolution

This setting controls the resolution and frame rate of your recorded videos.

- Higher resolutions (e.g., *4K 30FPS*) produce clearer, more detailed footage but use more space on the memory card.
- Lower resolutions (e.g., *720P 120FPS*) save storage space and may allow for longer recording times.

Follow these steps to adjust the video resolution:

1. **Open the Menu**
In Video Mode, press the **MENU** button.
2. **Select Video Resolution**
Use the **UP** or **DOWN** buttons to highlight *Video Resolution*, then press the **OK** button.
3. **Choose a Resolution**
Select from *4K 30FPS*, *2.7K 30FPS*, *1080P 60FPS*, or *720P 120FPS*.
4. **Confirm Your Selection**
Highlight your preferred option using the **UP** or **DOWN** buttons and press the **OK** button to confirm.
5. **Exit the Menu**
Press the **MENU** button to return to shooting mode

3.5 Video Recording Sound

This setting controls whether the camera records sound while capturing video.

- *On*: Audio is recorded along with the video.
- *Off*: Video is recorded silently without any sound.

Follow these steps to adjust the recording sound:

1. **Open the Menu**
In Video Mode, press the **MENU** button.
2. **Select Video Recording Sound**
Use the **UP** or **DOWN** buttons to highlight *Video Recording Sound*, then press the **OK** button.
3. **Choose an Option**
Select *On* or *Off*. A checkmark will indicate the selected option.
4. **Confirm Your Selection**
Press the **OK** button to apply the setting.
5. **Exit the Menu**
Press the **MENU** button to return to shooting mode.

3.6 Loop Recording

This setting enables the camera to automatically record videos in continuous segments of fixed duration. Once the memory card is full, the oldest files are overwritten with new footage.

- Choose a shorter duration (e.g., 2 minutes) to keep file sizes small and easy to manage.
- Recording will continue looping until you stop manually or the memory card runs out of space.

Follow these steps to adjust the loop recording setting:

1. **Open the Menu**
In Video Mode, press the **MENU** button.
2. **Select Loop Recording**
Use the **UP** or **DOWN** buttons to highlight *Loop Recording*, then press the **OK** button.
3. **Choose a Recording Duration**
Select from *Close*, *2 Minutes*, *3 Minutes*, or *5 Minutes*.
4. **Confirm Your Selection**
Highlight your choice using the **UP** or **DOWN** buttons and press the **OK** button to confirm.
5. **Exit the Menu**
Press the **MENU** button again to return to Video Mode.

3.7 Adjusting Video Quality

This setting controls how much visual detail is preserved in each video by adjusting the level of compression used when saving files to the memory card.

- *Super Fine* uses the least compression, resulting in the highest video quality and largest file size.
- *Fine* offers a balance between quality and storage space.
- *Normal* uses more compression to save space but may reduce image detail.

Follow these steps to adjust the video quality:

1. **Open the Menu**

In Video Mode, press the **MENU** button.

2. **Select Video Quality**

Use the **UP** or **DOWN** buttons to highlight *Video Quality*, then press the **OK** button.

3. **Choose a Quality Setting**

Select from *Normal*, *Fine*, or *Super Fine*.

4. **Confirm Your Selection**

Highlight your choice using the **UP** or **DOWN** buttons and press the **OK** button to confirm.

3.8 Applying Color Filter

This setting allows you to apply a creative filter to your videos before recording. Filters change the appearance of the footage by altering color, contrast, or visual style.

NOTE: Once a filter is applied and the video is recorded, the effect is permanent and cannot be removed.

Follow these steps to apply a color filter:

- 1. Open the Menu**
In Video Mode, press the **MENU** button.
- 2. Select Color Filter**
Use the **UP** or **DOWN** buttons to highlight *Color Filter*, then press the **OK** button.
- 3. Choose a Filter**
Select from *Normal, Black & White, Negative, Lomo, Dogeye, High Saturation, Red, Green, Blue, or Retro*.
- 4. Confirm Your Selection**
Highlight your choice using the **UP** or **DOWN** buttons and press the **OK** button to confirm.
- 5. Exit the Menu**
Press the **MENU** button again to return to Video Mode.

3.9 Adjusting White Balance

This setting adjusts the color tone of your videos to match the lighting environment. Choosing the correct setting ensures that whites appear neutral and all colors remain accurate.

- Use *Auto* for general recording in varied lighting conditions.
- Use *Sunny*, *Cloudy*, *Incandescent*, or *Fluorescent* to match specific lighting for better color accuracy.

Follow these steps to adjust the White Balance:

1. **Open the Menu**
In Video Mode, press the **MENU** button.
2. **Select White Balance**
Use the **UP** or **DOWN** buttons to highlight *White Balance*, then press the **OK** button.
3. **Choose a White Balance Setting**
Select from *Auto*, *Sunny*, *Cloudy*, *Incandescent*, or *Fluorescent*.
4. **Confirm Your Selection**
Highlight your choice using the **UP** or **DOWN** buttons and press the **OK** button to confirm.
5. **Exit the Menu**
Press the **MENU** button again to return to Video Mode.

3.10 Adjust ISO Setting

ISO controls the camera's sensitivity to light. This setting helps you maintain proper exposure when recording in different lighting conditions.

- Use lower ISO values (e.g., 100–400) in bright settings for sharper, cleaner video.
- Use higher ISO values (e.g., 1600–6400) in low-light settings, but expect more grain or visual noise.

Tip: Use Auto to let the camera select the best ISO for the scene.

Follow these steps to adjust the ISO setting:

1. **Open the Menu**
In Video Mode, press the **MENU** button.
2. **Select ISO**
Use the **UP** or **DOWN** buttons to highlight *ISO*, then press the **OK** button.
3. **Choose an ISO Setting**
Select from *Auto, 100, 200, 400, 800, 1600, 3200, or 6400*.
4. **Confirm Your Selection**
Highlight your choice using the **UP** or **DOWN** buttons and press the **OK** button to confirm.
5. **Exit the Menu**
Press the **MENU** button again to return to Video Mode.

3.11 Adjusting Contrast

This setting adjusts the difference between the light and dark areas in your video. Increasing contrast creates more dramatic shadows and brighter highlights; while lowering it results in a flatter, more muted image.

- Higher contrast (e.g., 4–5) emphasizes depth and detail.
- Lower contrast (e.g., 0–1) softens visual differences in the scene.

Follow these steps to adjust the contrast setting:

1. **Open the Menu**
In Video Mode, press the **MENU** button.
2. **Select Contrast**
Use the **UP** or **DOWN** buttons to highlight *Contrast*, then press the **OK** button.
3. **Choose a Contrast Level**
Select from *0, 1, 2, 3, 4, or 5*.
4. **Confirm Your Selection**
Highlight your choice using the **UP** or **DOWN** buttons and press the **OK** button to confirm.
5. **Exit the Menu**
Press the **MENU** button again to return to Video Mode.

3.12 Adjusting Exposure Value

This setting adjusts the overall brightness of your video. Increasing the exposure brightens the scene; while decreasing it darkens the image. This is useful when recording in especially bright or dark environments.

- Higher values (+1 to +3) make the video brighter.
- Lower values (-1 to -3) make the video darker.

Follow these steps to adjust exposure:

1. **Open the Menu**
In Video Mode, press the **MENU** button.
2. **Select Exposure**
Use the **UP** or **DOWN** buttons to highlight *Exposure*, then press the **OK** button.
3. **Choose an Exposure Value**
Select from -3, -2, -1, 0, 1, 2, or 3.
4. **Confirm Your Selection**
Highlight your choice using the **UP** or **DOWN** buttons and press the **OK** button to confirm.
5. **Exit the Menu**
Press the **MENU** button again to return to Video Mode.

3.13 Adjusting Metering Mode

Metering determines how the camera evaluates the lighting in a scene to set exposure. This setting adjusts how much of the frame is used to calculate brightness.

- *Spot Metering* measures light in a small focus area—ideal for backlit subjects.
- *Center Metering* evaluates the center of the frame, useful for off-center subjects.
- *Average* and *Matrix Metering* consider the whole frame for balanced exposure.

Follow these steps to adjust Metering Mode:

1. **Open the Menu**
Press the **MENU** button while in Photo Mode.
2. **Select Metering Mode**
Use the **UP** or **DOWN** buttons to highlight *Metering Mode*, then press the **OK** button.
3. **Choose a Metering Option**
Select from *Average Metering*, *Center Metering*, *Spot Metering*, or *Matrix Metering*.
4. **Confirm Your Selection**
Press the **OK** button to confirm.
5. **Exit the Menu**
Press the **MENU** button to return to shooting mode.

3.14 Adjusting LED Settings

This setting controls how the camera's LED light behaves during video recording. It helps brighten your subject in low-light conditions.

- *On* – The LED stays on continuously.
- *Auto* – The LED activates automatically based on lighting conditions.
- *Force* – The LED remains on regardless of lighting conditions.
- *Off* – The LED remains off at all times.

Follow these steps to adjust the LED light setting:

1. **Open the Menu**
Press the **MENU** button while in Video Mode.
2. **Select LED**
Use the **UP** or **DOWN** buttons to highlight *LED*, then press the **OK** button.
3. Choose an LED Mode
Select from *Off*, *On*, *Force*, or *Auto*.
4. **Confirm Your Selection**
Press the **OK** button to confirm.
5. **Exit the Menu**
Press the **MENU** button to return to Video Mode.

4.0 Time Lapse Mode

Time Lapse Mode allows the camera to automatically capture a series of short video clips at fixed intervals. These clips are later combined into a single video that plays back at a faster speed, making slow events—like sunsets or moving clouds—appear in motion.

- For example, a 10-second interval will instruct the camera to capture a short clip every 10 seconds.
- The final result is a time-lapse video created automatically by the camera.

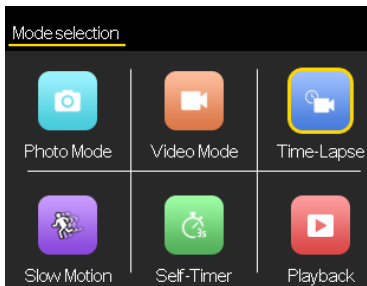

Follow these steps to use Time Lapse Mode:

1. **Enter Time Lapse Mode**

Power the camera on and press the **MODE** button to open the Shooting Mode menu.

Use the **LEFT**, **RIGHT**, **UP**, or **DOWN** buttons to highlight *Time Lapse Mode*, then press the **OK** button to confirm.

2. **Frame Your Scene**

Point the lens toward your subject and use the LCD monitor to compose the shot.

Use the **ZOOM** buttons to adjust between Tele and Wide views.

3. **Focus Your Subject**

Press the **SHUTTER** button halfway to focus.

- If the focus frame turns green, the subject is in focus.
- If the frame turns red, adjust your distance or composition and try again.

4. **Begin Capturing**

Fully press the **SHUTTER** button to start the time-lapse sequence. The camera will automatically capture clips based on the selected time interval.

NOTE: You will not need to press the SHUTTER button for each interval. The camera captures automatically until the duration completes or you stop recording.

4.1 Time Lapse Mode Settings

The settings menu in Time Lapse Mode allows you to configure how frequently the camera captures video segments. These options let you create time-lapse sequences by setting the duration between each recorded frame.

- Only time-lapse-specific settings will appear while in Time Lapse Mode.
- Use the LEFT or RIGHT buttons to switch between Photo, Video, and System menus if needed.

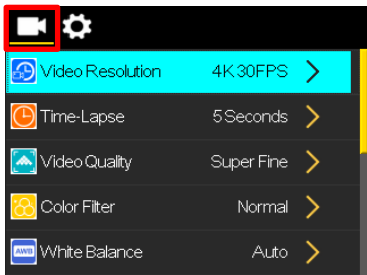

Follow these steps to access and navigate the Time Lapse settings:

1. **Open the Menu**
While in Time Lapse Mode, press the **MENU** button.
2. **Switch Between Menus**
Use the **LEFT** or **RIGHT** buttons to switch between Photo, Video, and System settings.
3. **Scroll Through Menu Options**
Use the **UP** or **DOWN** buttons to highlight a setting such as Interval Time or Duration.
4. **Confirm a Selection**
Press the **OK** button to enter a submenu or apply a setting.
5. **Exit the Menu**
Press the **MENU** button again to return to Time Lapse Mode.

4.1 Adjusting Time Lapse Video Resolution

This setting controls the resolution and frame rate of your time-lapse video recordings.

- Higher resolutions (e.g., 4K 30FPS) create sharper, more detailed time-lapse videos but use more space on the memory card.
- Lower resolutions (e.g., 720P 120FPS) save storage space and may allow for longer capture durations.

Follow these steps to adjust the time-lapse resolution:

1. **Open the Menu**
In Time Lapse Mode, press the **MENU** button.
2. **Select Video Resolution**
Use the **UP** or **DOWN** buttons to highlight *Video Resolution*, then press the **OK** button.
3. **Choose a resolution**
Select from *4K 30FPS*, *2.7K 30FPS*, *1080P 60FPS*, or *720P 120FPS*.
4. **Confirm your selection**
Highlight your preferred option using the **UP** or **DOWN** buttons and press the **OK** button to confirm.
5. **Exit the menu**
Press the **MENU** button to return to Time Lapse shooting mode.

4.2 Setting the Time Lapse Duration

This setting controls how long the camera will continue capturing during Time Lapse Mode.

- A longer duration (e.g., 60 seconds) results in more captured frames and a longer time-lapse video.
- A shorter duration (e.g., 3 or 5 seconds) creates a quick, condensed sequence.

Follow these steps to adjust the time lapse duration:

1. **Open the Menu**
In Time Lapse Mode, press the **MENU** button.
2. **Select Time Lapse**
Use the **UP** or **DOWN** buttons to highlight *Time Lapse*, then press the **OK** button.
3. **Choose a Duration**
Select from *3 Seconds*, *5 Seconds*, *10 Seconds*, *30 Seconds*, or *60 Seconds*.
4. **Confirm your selection**
Use the **UP** or **DOWN** buttons to highlight your choice, then press the **OK** button.
5. **Exit the Menu**
Press the **MENU** button to return to shooting mode.

4.3 Adjusting Video Quality (Time Lapse Mode)

This setting controls how much visual detail is preserved in each time-lapse video by adjusting the level of compression used when saving files to the memory card.

- *Super Fine* uses the least compression, resulting in the highest quality and largest file size.
- *Fine* offers a balance between video quality and memory usage.
- *Normal* uses higher compression to save space but may reduce image clarity.

Follow these steps to adjust the video quality:

1. **Open the Menu**
In Time Lapse Mode, press the **MENU** button.
2. **Select Video Quality**
Use the **UP** or **DOWN** buttons to highlight *Video Quality*, then press the **OK** button.
3. **Choose a Quality Setting**
Select from *Normal*, *Fine*, or *Super Fine*.
4. **Confirm your selection**
Use the **UP** or **DOWN** buttons to highlight your choice, then press the **OK** button.
5. **Exit the Menu**
Press the **MENU** button to return to Time Lapse Mode.

4.4 Applying a Color Filter (Time Lapse Mode)

This setting allows you to apply a creative filter to your time-lapse videos before recording. Filters change the visual style by altering color, contrast, or overall appearance.

NOTE: Once a filter is applied and the video is recorded, the effect is permanent and cannot be removed.

Follow these steps to apply a color filter:

- 1. Open the Menu**
In Time Lapse Mode, press the **MENU** button.
- 2. Select Color Filter**
Use the **UP** or **DOWN** buttons to highlight *Color Filter*, then press the **OK** button.
- 3. Choose a Filter**
Select from *Normal, Black & White, Negative, Lomo, Dogeye, High Saturation, Red, Green, Blue, or Retro*.
- 4. Confirm your selection**
Use the **UP** or **DOWN** buttons to highlight your choice, then press the **OK** button.
- 5. Exit the Menu**
Press the **MENU** button again to return to Time Lapse Mode.

4.5 Adjusting White Balance (Time Lapse Mode)

This setting adjusts the color tone of your videos to match the lighting conditions, helping scenes appear more natural. Different types of light can make footage look too warm or too cool if not corrected.

Tip: Use Auto for most situations, or manually select a mode based on your lighting.

Follow these steps to adjust White Balance:

- 1. Open the Menu**
Press the **MENU** button while in Time Lapse Mode.
- 2. Select White Balance**
Use the **UP** or **DOWN** buttons to highlight *White Balance*, then press the **OK** button.
- 3. Choose a White Balance Setting**
Select from *Auto, Sunny, Cloudy, Incandescent, or Fluorescent*.
- 4. Confirm Your Selection**
Press the **OK** button to confirm.
- 5. Exit the Menu**
Press the **MENU** button to return to Time Lapse Mode.

4.6 Adjusting ISO Setting (Time Lapse Mode)

ISO controls the camera's sensitivity to light. This setting helps you maintain proper exposure when recording in different lighting conditions.

- Use lower ISO values (e.g., 100–400) in bright settings for sharper, cleaner video.
- Use higher ISO values (e.g., 1600–6400) in low-light settings, but expect more grain or visual noise.

Tip: Use Auto to let the camera select the best ISO for the scene.

Follow these steps to adjust the ISO setting:

1. **Open the Menu**
Press the **MENU** button while in Time Lapse Mode.
2. **Select ISO**
Use the **UP** or **DOWN** buttons to highlight *ISO*, then press the **OK** button.
3. **Choose an ISO Setting**
Select from *Auto, 100, 200, 400, 800, 1600, 3200, or 6400*.
4. **Confirm Your Selection**
Highlight your choice using the **UP** or **DOWN** buttons and press the **OK** button to confirm.
5. **Exit the Menu**
Press the **MENU** button to return to Time Lapse Mode.

4.7 Adjusting Contrast (Time Lapse Mode)

This setting adjusts the difference between the light and dark areas in your video. Increasing contrast creates more dramatic shadows and brighter highlights; while lowering it results in a flatter, more muted image.

- Higher contrast (e.g., 4–5) emphasizes depth and detail.
- Lower contrast (e.g., 0–1) softens visual differences in the scene.

Follow these steps to adjust the contrast setting:

1. **Open the Menu**
Press the **MENU** button while in Time Lapse Mode.
2. **Select Contrast**
Use the **UP** or **DOWN** buttons to highlight *Contrast*, then press the **OK** button.
3. **Choose a Contrast Level**
Select from *0, 1, 2, 3, 4, or 5*.
4. **Confirm Your Selection**
Highlight your choice using the **UP** or **DOWN** buttons and press the **OK** button to confirm.
5. **Exit the Menu**
Press the **MENU** button again to return to Time Lapse Mode.

4.8 Adjusting Exposure (Time Lapse Mode)

This setting adjusts the overall brightness of your video. Increasing the exposure brightens the scene; while decreasing it darkens the image. This is useful when recording in especially bright or dark environments.

- Higher values (+1 to +3) make the video brighter.
- Lower values (-1 to -3) make the video darker.

Follow these steps to adjust exposure:

1. **Open the Menu**
Press the **MENU** button while in Time Lapse Mode.
2. **Select Exposure**
Use the **UP** or **DOWN** buttons to highlight *Exposure*, then press the **OK** button.
3. **Choose an Exposure Value**
Select from -3, -2, -1, 0, 1, 2, or 3.
4. **Confirm Your Selection**
Highlight your choice using the **UP** or **DOWN** buttons and press the **OK** button to confirm.
5. **Exit the Menu**
Press the **MENU** button again to return to Time Lapse Mode.

4.9 Adjusting Metering Mode (Time Lapse Mode)

Metering determines how the camera evaluates the lighting in a scene to set exposure. This setting adjusts how much of the frame is used to calculate brightness.

- *Spot Metering* measures light in a small focus area—ideal for backlit subjects.
- *Center Metering* evaluates the center of the frame, useful for off-center subjects.
- *Average* and *Matrix Metering* consider the whole frame for balanced exposure.

Follow these steps to adjust Metering Mode:

1. **Open the Menu**
Press the **MENU** button while in Time Lapse Mode.
2. **Select Metering Mode**
Use the **UP** or **DOWN** buttons to highlight *Metering Mode*, then press the **OK** button.
3. **Choose a Metering Option**
Select from *Average Metering*, *Center Metering*, *Spot Metering*, or *Matrix Metering*.
4. **Confirm Your Selection**
Press the **OK** button to confirm.
5. **Exit the Menu**
Press the **MENU** button to return to Time Lapse Mode.

4.10 Adjusting LED Settings (Time Lapse Mode)

This setting controls how the camera's LED light behaves during video recording. It helps brighten your subject in low-light conditions.

- *On* – The LED stays on continuously.
- *Auto* – The LED activates automatically based on lighting conditions.
- *Force* – The LED remains on regardless of lighting conditions.
- *Off* – The LED remains off at all times.

Follow these steps to adjust the LED light setting:

1. **Open the Menu**
Press the **MENU** button while in Time Lapse Mode.
2. **Select LED**
Use the **UP** or **DOWN** buttons to highlight *LED*, then press the **OK** button.
3. **Choose an LED Mode**
Select from *Off*, *On*, *Force*, or *Auto*.
4. **Confirm Your Selection**
Press the **OK** button to confirm.
5. **Exit the Menu**
Press the **MENU** button to return to Time Lapse Mode.

5.0 Slow Motion Mode

Slow Motion Mode records video at a high frame rate, allowing the footage to play back in smooth slow motion. This is ideal for capturing fast motion in detail, such as splashes, jumps, or quick movements.

- Playback speed is determined by the selected resolution and frame rate (e.g., 1080P at 60FPS plays back at half speed, 720P at 120FPS plays back at one-quarter speed).
- A 5-second recording at 720P 120FPS will result in a 20-second slow-motion video.
- Zoom and focus can still be used during recording. Higher resolution settings reduce the total recording time available on the memory card.
- Sound is not recorded in Slow Motion Mode.
- During recording, the time counter will increment in real time. The maximum available recording time depends on the selected resolution and frame rate.
- Higher resolutions use more space and allow for shorter recordings.
- Lower resolutions allow for longer recording times.

You can change the resolution before recording by opening the settings menu.

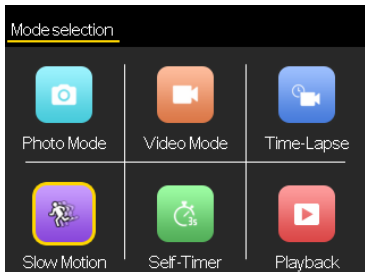

Follow these steps to use Slow Motion Mode:

- 1. Power on the camera**
Press the **MODE** button to open the shooting mode selection screen.
- 2. Select Slow Motion Mode**
Use the **LEFT**, **RIGHT**, **UP**, or **DOWN** buttons to highlight **Slow Motion Mode**, then press the **OK** button to confirm.
- 3. Frame your shot**
Point the lens at your subject and use the LCD monitor to compose the scene.
- 4. Adjust zoom**
Press the **T** button to zoom in, or the **W** button to zoom out.
- 5. Focus your subject**
Press the **SHUTTER** button halfway to focus. When the focus frame turns green, fully press the **SHUTTER** button to begin recording. You may also half-press the **SHUTTER** button during recording to refocus.
- 6. Stop recording**
Fully press the **SHUTTER** button again to stop recording. Each recording is saved as a separate file.

5.1 Slow Motion Settings

The settings menu in Slow Motion Mode allows you to adjust video resolution, quality, filters, and other shooting parameters specific to high-frame-rate recording.

- Only slow-motion-related settings will appear while in this mode
- Use the **LEFT** or **RIGHT** buttons to access general or photo settings if needed

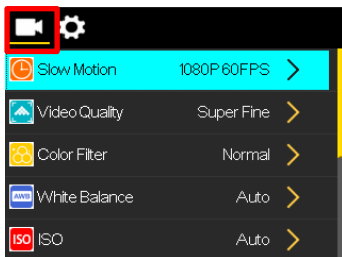

Follow these steps to access and navigate the settings menu:

1. **Open the Menu**
While in Slow Motion Mode, press the **MENU** button.
2. **Navigate Between Menus**
Use the **LEFT** or **RIGHT** buttons to switch between different settings categories.
3. **Scroll Through Menu Options**
Use the **UP** or **DOWN** buttons to highlight a menu item.
4. **Confirm a Selection**
Press the **OK** button to open a submenu or apply a setting.
5. **Exit the Menu**
Press the **MENU** button again to return to shooting mode.

5.2 Adjusting Slow Motion Resolution

This setting controls the resolution and frame rate of your slow-motion video recordings.

- Higher frame rates (e.g., 120FPS) create smoother slow-motion playback but use more space on the memory card.
- Lower frame rates (e.g., 60FPS) use less space and preserve more recording time.

Follow these steps to adjust the slow-motion resolution:

1. **Open the Menu**
In Slow Motion Mode, press the **MENU** button.
2. **Select Video Resolution**
Use the **UP** or **DOWN** buttons to highlight *Video Resolution*, then press the **OK** button.
3. **Choose a resolution**
Select from *1080P 60FPS* or *720P 120FPS*.
4. **Confirm your selection**
Highlight your preferred option using the **UP** or **DOWN** buttons and press the **OK** button to confirm.
5. **Exit the menu**
Press the **MENU** button to return to Slow Motion shooting mode.

5.3 Adjusting Video Quality (Slow Motion Mode)

This setting controls how much image detail is preserved in each video by adjusting the level of file compression.

- *Super Fine* uses the least compression, resulting in the highest video quality and largest file size.
- *Fine* offers a balance between quality and storage space.
- *Normal* uses more compression to save space but may reduce image detail.

Follow these steps to adjust the video quality:

1. **Open the Menu**
In Slow Motion Mode, press the **MENU** button.
2. **Select Video Quality**
Use the **UP** or **DOWN** buttons to highlight *Video Quality*, then press the **OK** button.
3. **Choose a quality setting**
Select from *Normal*, *Fine*, or *Super Fine*.
4. **Confirm your selection**
Highlight your choice using the **UP** or **DOWN** buttons and press the **OK** button to confirm.
5. **Exit the menu**
Press the **MENU** button to return to Slow Motion shooting mode.

5.4 Applying a Color Filter (Slow Motion Mode)

This setting allows you to apply a creative filter to your videos before recording. Filters change the appearance of the footage by altering color, contrast, or visual style.

NOTE: Once a filter is applied and the video is recorded, the effect is permanent and cannot be removed.

Follow these steps to apply a color filter:

- 1. Open the Menu**
In Slow Motion Mode, press the **MENU** button.
- 2. Select Color Filter**
Use the **UP** or **DOWN** buttons to highlight *Color Filter*, then press the **OK** button.
- 3. Choose a Filter**
Select from *Normal, Black & White, Negative, Lomo, Dogeye, High Saturation, Red, Green, Blue, or Retro*.
- 4. Confirm Your Selection**
Highlight your choice using the **UP** or **DOWN** buttons and press the **OK** button to confirm.
- 5. Exit the Menu**
Press the **MENU** button again to return to Slow Motion Mode.

5.5 Adjusting White Balance (Slow Motion Mode)

This setting adjusts the color tone of your video to match the lighting conditions. It helps ensure your footage doesn't appear too warm or too cool.

- Use *Auto* for most environments.
- Manually select a mode for more accurate color under specific lighting.

Follow these steps to adjust White Balance:

1. **Open the Menu**
In Slow Motion Mode, press the **MENU** button.
2. **Select White Balance**
Use the **UP** or **DOWN** buttons to highlight *White Balance*, then press the **OK** button.
3. **Choose a White Balance Option**
Select from *Auto*, *Sunny*, *Cloudy*, *Incandescent*, or *Fluorescent*.
4. **Confirm Your Selection**
Highlight your choice using the **UP** or **DOWN** buttons and press the **OK** button to confirm.
5. **Exit the Menu**
Press the **MENU** button to return to Slow Motion Mode.

5.6 Adjusting ISO (Slow Motion Mode)

ISO controls the camera's sensitivity to light. This setting helps you maintain proper exposure when recording in different lighting conditions.

- Use lower ISO values (e.g., 100–400) in bright settings for sharper, cleaner video.
- Use higher ISO values (e.g., 1600–6400) in low-light settings, but expect more grain or visual noise.

Tip: Use Auto to let the camera select the best ISO for the scene.

Follow these steps to adjust the ISO setting:

1. **Open the Menu**
In Slow Motion Mode, press the **MENU** button.
2. **Select ISO**
Use the **UP** or **DOWN** buttons to highlight *ISO*, then press the **OK** button.
3. **Choose an ISO Setting**
Select from *Auto*, 100, 200, 400, 800, 1600, 3200, or 6400.
4. **Confirm Your Selection**
Highlight your choice using the **UP** or **DOWN** buttons and press the **OK** button to confirm.
5. **Exit the Menu**
Press the **MENU** button to return to Slow Motion Mode.

5.7 Adjusting Contrast (Slow Motion Mode)

Contrast controls the difference between light and dark areas in your video. Adjusting this setting can help create more vivid or softer-looking footage.

- Higher contrast values (e.g., 4–5) create more intense shadows and highlights.
- Lower contrast values (e.g., 0–1) result in a flatter, more muted image.

Follow these steps to adjust the contrast setting:

1. **Open the Menu**
In Slow Motion Mode, press the **MENU** button.
2. **Select Contrast**
Use the **UP** or **DOWN** buttons to highlight *Contrast*, then press the **OK** button.
3. **Choose a Contrast Level**
Select from 0, 1, 2, 3, 4, or 5.
4. **Confirm Your Selection**
Highlight your choice using the **UP** or **DOWN** buttons and press the **OK** button to confirm.
5. **Exit the Menu**
Press the **MENU** button to return to Slow Motion Mode.

5.8 Adjusting Exposure (Slow Motion Mode)

Exposure controls the overall brightness of your video. This setting is especially useful in overly bright or dark environments.

- Higher values (+1 to +3) make the video brighter.
- Lower values (-1 to -3) darken the video.

Follow these steps to adjust the exposure setting:

1. **Open the Menu**
In Slow Motion Mode, press the **MENU** button.
2. **Select Exposure**
Use the **UP** or **DOWN** buttons to highlight *Exposure*, then press the **OK** button.
3. **Choose an Exposure Value**
Select from -3, -2, -1, 0, 1, 2, or 3.
4. **Confirm Your Selection**
Highlight your choice using the **UP** or **DOWN** buttons and press the **OK** button to confirm.
5. **Exit the Menu**
Press the **MENU** button to return to Slow Motion Mode.

5.9 Adjusting Metering Mode (Slow Motion Mode)

Metering determines how the camera evaluates the lighting in a scene to set the proper exposure. This setting adjusts how much of the frame the camera uses to measure brightness.

- *Spot Metering* measures light in a small focus area—ideal for backlit subjects.
- *Center Metering* evaluates the center of the frame, useful for off-center subjects.
- *Average* and *Matrix Metering* consider the whole frame for balanced exposure.

Follow these steps to adjust the metering mode:

1. **Open the Menu**
In Slow Motion Mode, press the **MENU** button.
2. **Select Metering Mode**
Use the **UP** or **DOWN** buttons to highlight *Metering Mode*, then press the **OK** button.
3. **Choose a Metering Option**
Select from *Average Metering*, *Center Metering*, *Spot Metering*, or *Matrix Metering*.
4. **Confirm Your Selection**
Press the **OK** button to confirm.
5. **Exit the Menu**
Press the **MENU** button to return to Slow Motion Mode.

5.10 Adjusting LED Settings (Slow Motion Mode)

This setting controls how the camera's LED light behaves during slow motion video recording. It helps illuminate your subject in low-light conditions.

- *On* – The LED stays on continuously.
- *Auto* – The LED activates automatically based on lighting conditions.
- *Force* – The LED remains on regardless of lighting conditions.
- *Off* – The LED remains off at all times.

Follow these steps to adjust the LED setting:

1. **Open the Menu**
In Slow Motion Mode, press the **MENU** button.
2. **Select LED**
Use the **UP** or **DOWN** buttons to highlight *LED*, then press the **OK** button.
3. **Choose an LED Mode**
Select from *Off*, *On*, *Force*, or *Auto*.
4. **Confirm Your Selection**
Press the **OK** button to confirm.
5. **Exit the Menu**
Press the **MENU** button to return to Slow Motion Mode.

6.0 Self-Timer Photo Mode 🕒

This mode enables a countdown timer that automatically captures a photo after a set delay. It's ideal for group shots or self-portraits without needing to press the shutter at the moment of capture.

- A 3-second setting delays photo capture by 3 seconds after pressing the shutter button.
- A 5-second setting gives more time to get into position before the photo is taken.
- The photo is captured automatically once the countdown finishes.

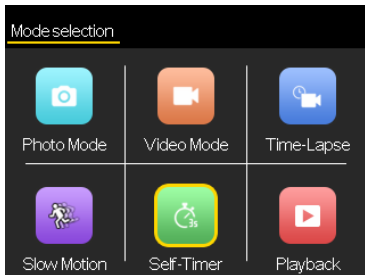

Follow these steps to use Self-Timer Photo Mode:

- 1. Enter Self-Timer Photo Mode**
Power on the camera and press the **MODE** button to enter the Shooting Mode menu.
Use the **LEFT**, **RIGHT**, **UP**, or **DOWN** buttons to highlight *Self-Timer Photo Mode*, then press the **OK** button to confirm.
- 2. Frame Your Subject**
Point the lens toward your subject and use the LCD monitor to compose the shot.
- 3. Adjust the Zoom**
Use the **T** or **W** buttons to zoom in or out.
- 4. Focus on the Subject**
Press the **SHUTTER** button halfway.
 - Green rectangles on the screen indicate that focus has been achieved.
 - Red rectangles mean the camera cannot focus clearly; adjust your distance if needed.
- 5. Capture the Photo**
Press the **SHUTTER** button fully to begin the countdown. The camera will automatically capture a photo once the selected delay time (e.g., 3, 5, or 10 seconds) has elapsed.

6.1 Self-Timer Settings (Photo Mode)

The settings menu in Self-Timer Photo Mode allows you to choose how long the camera waits before capturing a photo after pressing the shutter. This feature is helpful for group photos, self-portraits, or reducing motion blur from pressing the button.

- *3 Seconds* – Short delay for quick positioning
- *5 Seconds* – Moderate delay to allow time to step into frame
- *10 Seconds* – Longest delay, ideal for group setups or tripod shots

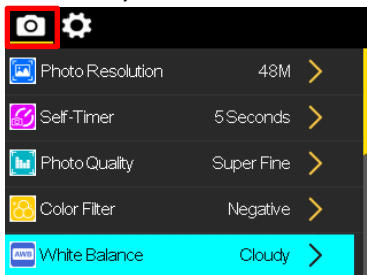

Follow these steps to access and navigate the settings menu:

1. **Open the Menu**
While in Self-Timer Photo Mode, press the **MENU** button.
2. **Navigate Between Menus**
Use the **LEFT** or **RIGHT** buttons to switch between different settings categories.
3. **Scroll Through Menu Options**
Use the **UP** or **DOWN** buttons to highlight *Self-Timer*.
4. **Confirm a Selection**
Press the **OK** button to open the submenu. Select from *3 Seconds*, *5 Seconds*, or *10 Seconds*, then press the **OK** button again to confirm.
5. **Exit the Menu**
Press the **MENU** button to return to Self-Timer shooting mode.

6.2 Adjusting Photo Resolution (Self-Timer Mode)

This setting controls the resolution of the photos captured while using Self-Timer mode.

- Higher resolutions (e.g., 64MP, 48MP) create sharper, more detailed images but use more space on the memory card.
- Lower resolutions (e.g., 8MP) save storage space but reduce image clarity.

Follow these steps to adjust the photo resolution:

1. **Open the Menu**
In Self-Timer Mode, press the **MENU** button.
2. **Select Photo Resolution**
Use the **UP** or **DOWN** buttons to highlight *Photo Resolution*, then press the **OK** button.
3. **Choose a Resolution**
Select from *64MP, 48MP, 24MP, or 8MP*.
4. **Confirm Your Selection**
Highlight your choice using the **UP** or **DOWN** buttons and press the **OK** button to confirm.
5. **Exit the Menu**
Press the **MENU** button to return to Self-Timer shooting mode.

6.3 Adjusting Photo Quality (Self-Timer Mode)

This setting controls how much image detail is preserved in each photo by adjusting the level of compression used when saving files to the memory card.

- *Super Fine* offers the highest image quality with the least compression but uses the most memory card space.
- *Fine* provides a good balance between quality and file size.
- *Normal* compresses photos more to save space, which may reduce detail.

Follow these steps to adjust the photo quality:

1. **Open the Menu**
In Self-Timer Mode, press the **MENU** button.
2. **Select Photo Quality**
Use the **UP** or **DOWN** buttons to highlight *Photo Quality*, then press the **OK** button.
3. **Choose a Quality Setting**
Select from *Normal*, *Fine*, or *Super Fine*.
4. **Confirm Your Selection**
Highlight your choice using the **UP** or **DOWN** buttons and press the **OK** button to confirm.
5. **Exit the Menu**
Press the **MENU** button to return to Self-Timer shooting mode.

6.4 Applying a Color Filter (Self-Timer Mode)

This setting allows you to apply a creative effect to your photos before they are taken. Filters change the visual style of the image by altering its color, contrast, or overall mood.

NOTE: Once a filter is applied and the photo is captured, the effect is permanent and cannot be removed.

Follow these steps to apply a color filter:

- 1. Open the Menu**
In Self-Timer Mode, press the **MENU** button.
- 2. Select Color Filter**
Use the **UP** or **DOWN** buttons to highlight *Color Filter*, then press the **OK** button.
- 3. Choose a Filter**
Select from *Normal, Black & White, Negative, Lomo, Dogeye, High Saturation, Red, Green, Blue, or Retro*.
- 4. Confirm Your Selection**
Highlight your choice using the **UP** or **DOWN** buttons and press the **OK** button to confirm.
- 5. Exit the Menu**
Press the **MENU** button to return to Self-Timer shooting mode.

6.5 Adjusting Auto White Balance (Self-Timer Mode)

This setting adjusts the color tone of your photos to match the lighting conditions, making images appear more natural. Different types of light can make photos look too warm or too cool if not corrected.

Tip: Use Auto for most situations, or manually select a mode based on your lighting.

Follow these steps to adjust White Balance:

- 1. Open the Menu**
In Self-Timer Mode, press the **MENU** button.
- 2. Select White Balance**
Use the **UP** or **DOWN** buttons to highlight *White Balance*, then press the **OK** button.
- 3. Choose a White Balance Option**
Select from *Auto*, *Sunny*, *Cloudy*, *Incandescent*, or *Fluorescent*.
- 4. Confirm Your Selection**
Highlight your choice using the **UP** or **DOWN** buttons and press the **OK** button to confirm.
- 5. Exit the Menu**
Press the **MENU** button to return to Self-Timer shooting mode.

6.6 Adjusting ISO Setting (Self-Timer Mode)

ISO controls the camera's sensitivity to light. This setting helps you maintain proper exposure when recording in different lighting conditions.

- Use lower ISO values (e.g., *100–400*) in bright settings for sharper, cleaner video.
- Use higher ISO values (e.g., *1600–6400*) in low-light settings, but expect more grain or visual noise.

Tip: Use Auto to let the camera select the best ISO for the scene.

Follow these steps to adjust the ISO setting:

1. **Open the Menu**
In Self-Timer Mode, press the **MENU** button.
2. **Select ISO**
Use the **UP** or **DOWN** buttons to highlight *ISO*, then press the **OK** button.
3. **Choose an ISO Setting**
Select from *Auto*, *100*, *200*, *400*, *800*, *1600*, *3200*, or *6400*.
4. **Confirm Your Selection**
Highlight your choice using the **UP** or **DOWN** buttons and press the **OK** button to confirm.
5. **Exit the Menu**
Press the **MENU** button to return to Self-Timer shooting mode.

6.7 Adjusting Exposure (Self-Timer Mode)

Exposure adjusts the brightness of your photo. This setting lets you make the image lighter or darker depending on your scene and lighting conditions.

- Higher values (+1 to +3) make the photo brighter.
- Lower values (-1 to -3) darken the photo.

Follow these steps to adjust the exposure value:

1. **Open the Menu**
In Self-Timer Mode, press the **MENU** button.
2. **Select Exposure**
Use the **UP** or **DOWN** buttons to highlight *Exposure*, then press the **OK** button.
3. **Choose an Exposure Value**
Select from -3, -2, -1, 0, 1, 2, or 3.
4. **Confirm Your Selection**
Press the **OK** button to confirm.
5. **Exit the Menu**
Press the **MENU** button to return to Self-Timer shooting mode.

6.8 Adjusting Metering Mode (Self-Timer Mode)

Metering determines how the camera evaluates the lighting in a scene to set the proper exposure. This setting adjusts how much of the frame the camera uses to measure brightness.

- *Spot Metering* measures light in a small focus area—ideal for backlit subjects.
- *Center Metering* evaluates the center of the frame, useful for off-center subjects.
- *Average* and *Matrix Metering* consider the whole frame for balanced exposure.

Follow these steps to adjust the metering mode:

1. **Open the Menu**
In Self-Timer Mode, press the **MENU** button.
2. **Select Metering Mode**
Use the **UP** or **DOWN** buttons to highlight *Metering Mode*, then press the **OK** button.
3. **Choose a Metering Option**
Select from *Average Metering*, *Center Metering*, *Spot Metering*, or *Matrix Metering*.
4. **Confirm Your Selection**
Press the **OK** button to confirm.
5. **Exit the Menu**
Press the **MENU** button to return to Self-Timer shooting mode.

6.9 Adjusting LED Setting (Self-Timer Mode)

This setting controls how the camera's LED light behaves when capturing photos using the self-timer. It helps illuminate your subject in low-light environments.

- *On* – The LED stays on continuously.
- *Auto* – The LED activates automatically based on lighting conditions.
- *Force* – The LED remains on regardless of lighting conditions.
- *Off* – The LED remains off at all times.

Follow these steps to adjust the LED light setting:

1. **Open the Menu**
In Self-Timer Mode, press the **MENU** button.
2. **Select LED**
Use the **UP** or **DOWN** buttons to highlight *LED*, then press the **OK** button.
3. **Choose an LED Mode**
Select from *Off*, *On*, *Force*, or *Auto*.
4. **Confirm Your Selection**
Press the **OK** button to confirm.
5. **Exit the Menu**
Press the **MENU** button to return to Self-Timer shooting mode

7.0 Playback Mode

This mode allows you to review and manage all of your captured photos and videos. Use it to view, scroll through, or delete stored media directly on the camera's screen.

- Review photos and videos saved on the memory card
- Delete unwanted media directly from the camera
- Use navigation buttons to move through your captured files

Follow these steps to enter Playback Mode:

1. **Power On the Camera**

Turn the camera on by pressing the **POWER** button.

2. **Enter Shooting Mode Navigation**

Press the **MODE** button to access the shooting mode selection screen.

3. **Select Playback Mode**

Use the **LEFT**, **RIGHT**, **UP**, or **DOWN** buttons to highlight *Playback Mode*, then press the **OK** button to confirm.

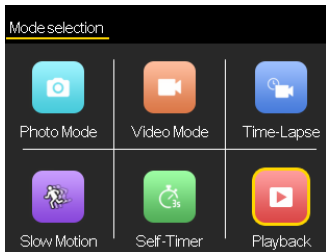

7.1 Playback Mode Navigation and Screen Explanation

Explanation

Playback Mode Navigation and Screen Explanation Once you enter Playback mode, use the LEFT and RIGHT buttons to navigate through all the captured files. Below is an explanation of each of the button's functions when in Playback mode.

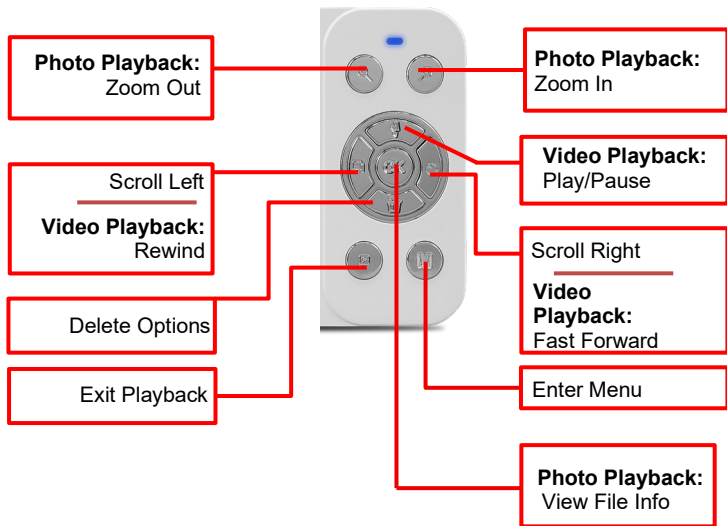

7.2 Photo Playback Screen Explanation



Photo Playback

7.3 Video Playback Screen Explanation



Video Playback

7.4 Deleting Files

Playback Mode includes a simple delete menu that allows you to manage storage space by removing unwanted files.

- To delete a single file or all files, access the delete menu while viewing your media
- You can also choose to cancel and return without deleting any files

Follow these steps to access the delete options:

1. **Open the Delete Menu**
While in Playback Mode, press the **DOWN** (Delete) button.
2. **Navigate to System Settings (Optional)**
To access general system settings, press the **LEFT** or **RIGHT** buttons after opening the delete menu.
3. **Choose a Delete Option**
You may select from the following:
 - *Delete Current* – Removes the currently displayed file
 - *Delete All* – Removes all saved photos and videos
 - *Exit* – Leaves the menu without deleting anything
4. **Confirm Your Selection**
Highlight your choice and press the **OK** button to confirm.
5. **Exit the Menu**
Press the **MENU** button to return to Playback Mode

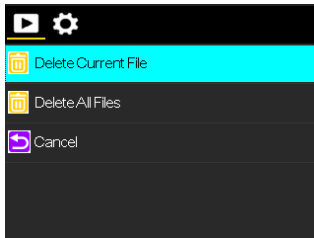

7.5 Accessing System Settings in Playback Mode

While in Playback Mode, you can access a variety of system-level settings that control the behavior and appearance of the camera. These options allow you to change the interface language, adjust power-saving features, manage sounds, and reset the system. These settings do not affect your photos or videos but help personalize how the camera functions.

To access these settings:

- 1. Enter Playback Mode**
Power on the camera and press the **MODE** button. Use the **LEFT**, **RIGHT**, **UP**, or **DOWN** buttons to select Playback Mode. Press the **OK** button to confirm.
- 2. Open the Settings Menu**
Press the **DOWN** button, then press the **RIGHT** button to switch to the system settings menu. Press the **OK** button to enter.
- 3. Exit the Menu**
Press the **MENU** button to return to Playback Mode

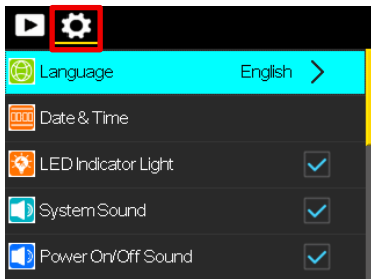

8.0 System Settings

The System Settings menu contains system-wide options that control camera behavior, display, sounds, and default preferences.

To access the system settings menu, press the **MENU** button. Once in the menu, use the **LEFT** and **RIGHT** buttons to navigate to the General Settings tab, indicated by a gear icon. Use the **UP** and **DOWN** buttons to scroll through menu options. To confirm a selection, press the **OK** button.

NOTE: When in Playback Mode, press the **DOWN** button to access these settings.

8.1 Adjusting System Language

This setting changes the language used in all camera menus and on-screen prompts.

Follow these steps to change the system language:

- 1. Open General Settings**
Press the **MENU** button, then use the **LEFT** or **RIGHT** buttons to access the General Settings tab.
- 2. Select Language**
Use the **UP** or **DOWN** buttons to highlight Language, then press the **OK** button.
- 3. Choose a Language**
Highlight your preferred language using the **UP** or **DOWN** buttons.
- 4. Confirm Your Selection**
Press the **OK** button to apply the change.
- 5. Exit the Menu**
Press the **MODE** button to return to shooting mode.

8.2 Setting Date and Time

This setting adjusts the camera's internal clock for accurate time stamps on photos and videos.

Follow these steps to set the date and time:

- 1. Open General Settings**
Press the **MENU** button, then use the **LEFT** or **RIGHT** buttons to access the General Settings tab.
- 2. Select Date & Time Setup**
Use the **UP** or **DOWN** buttons to highlight *Date & Time Setup*, then press the **OK** button.
- 3. Adjust Each Field**
Use the **LEFT** or **RIGHT** buttons to move between date and time fields, and use the **UP** or **DOWN** buttons to adjust the values.
- 4. Confirm Your Settings**
Press the **OK** button to save each value.
- 5. Exit the Menu**
Press the **MODE** button to return to shooting mode.

8.3 Light Frequency

This setting adjusts the camera's operating frequency to match the local power supply and avoid flickering in videos or photos under artificial lighting.

- *Auto* – The camera automatically detects and sets the correct frequency.
- *50Hz* – Common in regions such as Europe, Asia, and Africa.
- *60Hz* – Common in regions such as the United States, Canada, and parts of South America.

Follow these steps to set the light frequency:

1. **Open the Menu**
In any mode, press the **MENU** button.
2. **Access General Settings**
Press the **RIGHT** button to navigate to the general settings menu.
3. **Select Light Frequency**
Use the **UP** or **DOWN** buttons to highlight *Light Frequency*, then press the **OK** button.
4. **Choose a Frequency**
Select from *Auto*, *50Hz*, or *60Hz*.
5. **Confirm Your Selection**
Press the **OK** button to apply the setting.
6. **Exit the Menu**
Press the **MENU** button to return to shooting mode.

8.4 LED Indicator Light

This setting turns the camera's indicator light on or off.

- *On* – The indicator light will be visible during camera operation.
- *Off* – The indicator light will remain off at all times.

Follow these steps to adjust the LED indicator light:

1. **Open General Settings**

Press the **MENU** button, then use the **LEFT** or **RIGHT** buttons to access the General Settings tab.

2. **Select LED Indicator Light**

Use the **UP** or **DOWN** buttons to highlight *LED Indicator Light*, then press the **OK** button.

3. **Choose an Option**

Select *On* or *Off*. A checkmark will appear next to the active setting.

4. **Confirm Your Selection**

Press the **OK** button to apply the setting.

5. **Exit the Menu**

Press the **MODE** button to return to shooting mode.

8.5 System Sound

This setting enables or disables sounds for menu navigation and camera operations.

- *On* – Sounds play when navigating menus or performing actions.
- *Off* – Sounds are muted.

Follow these steps to adjust system sounds:

1. **Open General Settings**
Press the **MENU** button, then use the **LEFT** or **RIGHT** buttons to access the General Settings tab.
2. **Select System Sound**
Use the **UP** or **DOWN** buttons to highlight System Sound, then press the **OK** button.
3. **Choose an Option**
Select *On* or *Off*. A checkmark will appear next to the active setting.
4. **Confirm Your Selection**
Press the **OK** button to apply the setting.
5. **Exit the Menu**
Press the **MODE** button to return to shooting mode.

8.6 Power On/Off Sound

This setting turns the startup and shutdown sound on or off.

- *On* – Plays a tone when the camera powers on or off.
- *Off* – Disables the tone.

Follow these steps to adjust the power on/off sound:

1. **Open General Settings**
Press the **MENU** button, then use the **LEFT** or **RIGHT** buttons to access the General Settings tab.
2. **Select Power On/Off Sound**
Use the **UP** or **DOWN** buttons to highlight Power On/Off Sound, then press the **OK** button.
3. **Choose an Option**
Select *On* or *Off*. A checkmark will appear next to the active setting.
4. **Confirm Your Selection**
Press the **OK** button to apply the setting.
5. **Exit the Menu**
Press the **MODE** button to return to shooting mode.

8.7 Auto Screen Off

This setting automatically turns off the display after a set time to save battery power.

- *10 Seconds* – Turns off after 10 seconds of inactivity.
- *20 Seconds* – Turns off after 20 seconds of inactivity.
- *30 Seconds* – Turns off after 30 seconds of inactivity.
- *Close* – Disables auto screen off.

Follow these steps to adjust the auto screen off timer:

1. **Open General Settings**
Press the **MENU** button, then use the **LEFT** or **RIGHT** buttons to access the General Settings tab.
2. **Select Auto Screen Off**
Use the **UP** or **DOWN** buttons to highlight *Auto Screen Off*, then press the **OK** button.
3. **Choose a Duration**
Select from *10 Seconds*, *20 Seconds*, *30 Seconds*, or *Close*.
4. **Confirm Your Selection**
Press the **OK** button to apply the setting.
5. **Exit the Menu**
Press the **MODE** button to return to shooting mode.

8.8 Auto Power Off

This setting powers down the camera automatically after a set period of inactivity.

- *3 Minutes* – Powers off after 3 minutes of inactivity.
- *5 Minutes* – Powers off after 5 minutes of inactivity.
- *30 Minutes* – Powers off after 30 minutes of inactivity.
- *Close* – Disables auto power off.

Follow these steps to adjust auto power off:

1. **Open General Settings**
Press the **MENU** button, then use the **LEFT** or **RIGHT** buttons to access the General Settings tab.
2. **Select Auto Power Off**
Use the **UP** or **DOWN** buttons to highlight *Auto Power Off*, then press the **OK** button.
3. **Choose a Duration**
Select from *3 Minutes*, *5 Minutes*, *30 Minutes*, or *Close*.
4. **Confirm Your Selection**
Press the **OK** button to apply the setting.
5. **Exit the Menu**
Press the **MODE** button to return to shooting mode.

8.9 Date & Time Stamp

This setting imprints the current date and time onto your captured photos and videos. Once a file is saved with this imprint, it cannot be removed.

Follow these steps to adjust the Date & Time Stamp setting:

- 1. Open the Menu**
In any mode, press the **MENU** button.
- 2. Select Date & Time Stamp**
Use the UP or DOWN buttons to highlight Date & Time Stamp.
- 3. Choose an Option**
Select *On* or *Off*. A checkmark will appear next to the active setting.
- 4. Confirm Your Selection**
Press the **OK** button to confirm.
- 5. Exit the Menu**
Press the **MENU** button to return to shooting mode.

8.10 Format Memory Card

This setting erases all media and data stored on the memory card.

NOTE: This action is permanent and cannot be undone.

Follow these steps to format the memory card:

- 1. Open General Settings**
Press the **MENU** button, then use the **LEFT** or **RIGHT** buttons to access the General Settings tab.
- 2. Select Format Memory Card**
Use the **UP** or **DOWN** buttons to highlight *Format Memory Card*, then press the **OK** button.
- 3. Confirm Formatting**
Select Yes to proceed or Cancel to exit.
- 4. Finalize the Action**
Press the **OK** button to confirm.
- 5. Exit the Menu**
Press the **MODE** button to return to shooting mode.

8.11 Viewing Firmware Version

This setting displays the current firmware version installed on the camera. It is useful for troubleshooting, checking for updates, or confirming that your camera is running the latest software.

Follow these steps to view the firmware version:

- 1. Open the Menu**
In any mode, press the **MENU** button.
- 2. Select FW Version**
Use the **UP** or **DOWN** buttons to highlight *FW Version*, then press the **OK** button.
- 3. View Firmware Information**
The current firmware version will be shown on the screen.
- 4. Exit the Menu**
Press the **MENU** button to return to shooting mode.

8.12 Flip Screen

This setting flips the display upside down, useful when the camera is mounted in an inverted position.

- *On* – Flips the display.
- *Off* – Keeps the display in its default orientation.

Follow these steps to flip the screen:

1. **Open General Settings**
Press the **MENU** button, then use the **LEFT** or **RIGHT** buttons to access the General Settings tab.
2. **Select Flip Screen**
Use the **UP** or **DOWN** buttons to highlight *Flip Screen*, then press the **OK** button.
3. **Choose an Option**
Select *On* or *Off*. A checkmark will appear next to the active setting.
4. **Confirm Your Selection**
Press the **OK** button to apply the setting.
5. **Exit the Menu**
Press the **MODE** button to return to shooting mode.

8.13 Reset to Default

This setting restores all menu settings to factory defaults without deleting media stored on the memory card.

Follow these steps to reset to default:

- 1. Open General Settings**
Press the **MENU** button, then use the **LEFT** or **RIGHT** buttons to access the General Settings tab.
- 2. Select Reset to Default**
Use the **UP** or **DOWN** buttons to highlight *Reset to Default*, then press the **OK** button.
- 3. Confirm Reset**
Select Yes to proceed or Cancel to exit.
- 4. Finalize the Action**
Press the **OK** button to confirm.
- 5. Exit the Menu**
Press the **MODE** button to return to shooting mode.

9.0 Technical Specifications

Model Number	Minolta MND33
Lens (Main)	Auto Focus • F/3.2 • f=7.36mm
Zoom	18X Digital Zoom
Photo Sensor	8MP CMOS Sensor
Shutter	Electronic • Digital Photo Stabilization
Pixels (photo)	JPEG: 64 Mega Pixels • 48 Mega Pixels • 24 Mega Pixels • 8 Mega Pixels
Pixels (video)	MP4: 4K (30 FPS) • 2.7K 30 FPS • 1080P (60 FPS) • 720P (120 FPS)
ISO Sensitivity	Auto • 100 • 200 • 400 • 800 • 1600 • 3200 • 6400
LCD Monitor	2.8" TFT+1.4" IPS LCD
Assistive Light	LED Flash • Video Light
Auto Power Off	OFF • 1 Minutes • 3 Minutes • 5 Minutes • 30 Minutes
White Balance Control	Auto • Sunny • Cloudy • Incandescent • Fluorescent

Color Filters	Normal • Dogeye • High Saturation • Red • Green • Blue • Retro • Black & White, • Negative • Lomo
Recording Media	MicroSD • MicroSDXC; Maximum: 256GB
I/O Ports	USB-C • Microphone (built-in) • Speaker (built-in)
Power	Lithium-Ion 3.7V, 750mAh (BL-5B)
Dimensions	3.87 x 2.32 x 1.08 in. • 5.1 oz.



MINOLTA®

Minolta is a registered trademark of JMM Lee Properties, LLC and is used in the United States by Elite Brands Inc. under license.

40 Wall Street, 61st Floor, New York, NY
10005 USA

www.minoltadigital.com •
www.elitebrands.com



Copyright © 2025 Elite Brands Inc.



MINOLTA®

MND33