



## X2 Series (4K) Network Video Streamer

# USER MANUAL

## X2UH-CAST

Follow us on Youtube  
and Facebook



[www.orei.com](http://www.orei.com)

# Table of Contents

Introduction	04
Features	05
Package Contents	06
Specifications	06
Operation Controls and Functions	08
Rack Mounting Instruction	11
Stream Service Introduction	14
Platform Building	14
WebGUI Operation	16
RTSP/TS Stream Operation	31
RTMP/RTMPS Push Stream (Youtube) Operation	35
Audio Only Stream Operation	38
Application Example	41
FAQs & Troubleshooting	42

## Thank you for purchasing this product

For optimum performance and safety, please read these instructions carefully before connecting, operating, or adjusting this product. Keep this manual for future reference.

### **Important Safety Note - Surge Protection Recommended**

This product contains sensitive electronic components that may be damaged by electrical spikes, surges, lightning strikes, or static discharge. To protect and extend the service life of your equipment, we strongly recommend using a surge protection device.

# Warranty Registration

Activate your warranty by registering your product at:

→ [www.orei.com/register](http://www.orei.com/register)

## ***Need Technical Support? We're Here to Help.***

Our experienced Technical Support Team is available to answer your questions, offer expert advice, and help troubleshoot any issues to keep your project on track—on time and on budget.

## **Live Support Hours (US/Canada/Mexico):**

 Monday–Friday | 9:00 a.m. – 5:00 p.m. Central Time

## **Contact Us:**

 Email: [info@orei.com](mailto:info@orei.com)

 Phone: 877-290-5530

 Chat Live: [www.orei.com](http://www.orei.com)

Send us an instant message—our team typically responds within moments during live support hours.

# Introduction

X2UH-CAST is a high-performance AV-over-IP encoder designed for professional AV distribution. Based on H.265/H.264 compression technology, it enables visually lossless 4K@60Hz (4:4:4) video transmission over a 100M/1G Ethernet network. Supporting three simultaneous streams (4K@60Hz H.264/H.265, 1080P@30Hz H.264, and 720P@50Hz JPEG), it ensures maximum flexibility for streaming, preview, and monitoring applications.

With HDMI™ loop-out, analog audio embedding/extracting, and full compatibility with streaming standards like RTSP, RTP, TS, RTMP/RTMPS, this AV Streamer is a versatile solution for broadcasting, control rooms, and AV-over-IP installations. Its Web GUI offers intuitive setup and management, while advanced API controls allow seamless integration with third-party control systems.

Compact and 1U/6U V2 rack-compatible, it supports PoE (802.3af), features an OLED display, and includes advanced functions like device discovery, unicast/multicast streaming, EDID configuration, and security with 802.1X protocol.

1. **4K@60Hz Ultra HD Encoding** – Supports H.264/H.265 HEVC with up to 18Gbps video bandwidth (HDMI™ 2.0b).
2. **Triple Stream Output** – 4K@60Hz H.264/H.265 + 1080P@30 H.264 + 720P@5 JPEG.
3. **Streaming Protocols** – RTSP/UDP, RTSP/TCP, RTP/UDP, TS/UDP, RTMP/RTMPS.
4. **Flexible Streaming** – Supports unicast, multicast, audio-only stream, and audio delay settings.
5. **Audio Support** – LPCM 2CH (48kHz), analog audio embedding & extraction.
6. **Signal Extension & Distribution** – HDMI™ loop-out, image preview, point-to-point, and one-to-many distribution.
7. **Advanced Control** – Web GUI (HTTP/HTTPS), API via TELNET/SSH/TCP socket, stream control (play/pause/stop).
8. **Network & Power** – 100M/1G Ethernet port with PoE (802.3af) support.
9. **Management & Security** – Device Discovery “SHOW ME” function, EDID configuration, 802.1X protocol.
10. **Installation Ready** – Compatible with 1U/6U V2 rack installation.

# Package Contents & Specifications

## Package Contents

1.	X2UH-CAST	1 pcs
2.	Mounting Ears	2pcs
3.	Machine Screws	4pcs
4.	Power Adapter	1 pcs
5.	User Manual	1 pcs

## Specifications

Technical	
HDMI™ Compliance	HDMI™ 2.0b
Video Bandwidth	18Gbps
Network Video Bandwidth	1G
Audio Latency	< 60ms
Input Video Resolution	Up to 4K@60Hz 4:4:4
Output Video Resolution	Push stream resolution: Same as input, 3840x2160, 1920x1080, 1280x720, 640x480 Push stream frame rate: 5~60Hz
Color Space	HDMI™ input: RGB, YCbCr 4:4:4 / 4:2:2 / 4:2:0 Push stream encoding: 4:2:0
Color Depth	HDMI™ input: 8/10/12bit Push stream output: 8bit

# Specifications

HDR	Not supported
Audio Formats	LPCM 2CH 48kHz
L/R OUT Audio Parameters	Output Impedance: 330 Ohms Line Input / Output Level (Maximum): 2Vrms Frequency Response: (+0.5dB, -1dB) 20Hz to 20kHz Audio S/N Ratio: >90dB@2Vrms, 1kHzA-weighted Audio THD+N: <0.05%@2Vrms, 1KHz
Transmission Distance	16ft/5m (HDMI™) 328ft/100m (CAT6/6A/7)
ESD Protection	IEC 61000-4-2: ±8kV (Air-gap discharge) & ±4kV (Contact discharge)
<b>Connection</b>	
Input ports	1x HDMI™ [Type A, 19-pin female] 1x 3.5mm [Stereo audio jack]
Output ports	1x HDMI™ [Type A, 19-pin female] 1x 3.5mm [Stereo audio jack]
Network port	1x LAN/PoE [RJ45 jack, support PoE 802.3af power supply]
<b>Mechanical</b>	
Housing	Aluminum+Iron
Color	Black
Dimensions	L: 130mm / 5.12in; W: 160mm / 6.30in; H: 30mm / 1.18in
Weight	659g / 1.45lbs
Power Consumption	7.2W
Power Supply	Input: AC100 - 240V 50/60Hz, Output: DC 12V/1A (US/EU standards, CE/FCC/UL certified)
Operation Temperature	0°C ~ 40°C / 32°F ~ 104°F
Storage Temperature	-20°C ~ 60°C / -4°F ~ 140°F
Operating Humidity	20%-80% (relative humidity, non-condensing)
Storage Humidity	10%-90% (relative humidity, non-condensing)

# Operation Controls and Functions

## Front Panel

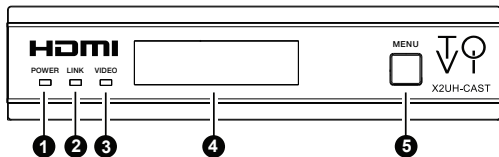

No.	Name	Function Description
1.	POWER LED (Green)	The LED lights up when the unit is powered on.
2.	LINK LED (Green)	The Link LED shows the current network and streaming status of the device: <b>Solid Light</b> - A stable 1G network connection is detected. <b>Off</b> - The device is not connected to the network. <b>Flashing (1Hz)</b> - The device is actively streaming video over the network.
3.	VIDEO LED (Green)	This LED indicates the current status of the video signal being transmitted: <b>Solid Light</b> - The video signal is locked and transmitting normally. <b>Off</b> - There is no video signal being transmitted. <b>Flashing (2Hz)</b> - A video signal is present but not locked (unstable or still negotiating).
4.	OLED display screen	After powering on, the OLED screen shows the device name and IP address (homepage). It begins scrolling after 10 seconds and automatically turns off after 60 seconds. Notes: If the screen is off, press <b>MENU</b> to wake it. When the screen is lit or scrolling, press <b>MENU</b> to cycle through pages. When waking from off, the OLED always returns to the first page.

# Operation Controls and Functions

No.	Name	Function Description
5.	MENU button	<ul style="list-style-type: none"><li>Press the MENU button to turn on the OLED screen or select different page contents.</li><li>Hold down the MENU button for 10 seconds to restore the unit to factory default settings.</li></ul>

**Note:** When the SHOW ME function is turned on, both the LINK and VIDEO LED will flash at 5Hz.

## Rear Panel

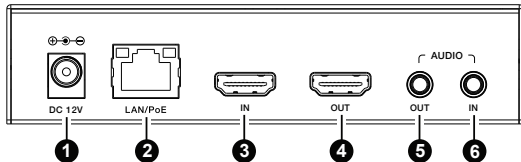

No.	Name	Function Description
1.	DC 12V	Connect the included power adapter to power the device. However, it can also accept PoE from the LAN port, no longer needing the power adapter.
2.	LAN/PoE	1G Ethernet port that supports 802.3af PoE for powering the device. Use this port to connect the streamer LAN to your network switch or other network equipment for IP video streaming.
3.	IN	Connect a media source device such as DVD player, streaming device, etc.

# Operation Controls and Functions

No.	Name	Function Description
4.	OUT	Connect a display device such as TV, Monitor, etc.
5.	AUDIO OUT	Connect an audio device such as headphone, soundbar, etc.
6.	AUDIO IN	This port allows you to embed external analog audio into the video stream. The encoder and streaming output will use the audio from the AUDIO IN port, while the HDMI Loop Out continues to output the original audio from the HDMI IN source.

# Rack Mounting Instruction

## 6U V2 Rack Mounting

This product can be mounted in a standard 6U V2 rack (available on the OREI website). The mounting steps are as follows:

**Step 1:** Use included screws to fix two mounting ears on the product, as shown in the figure below:

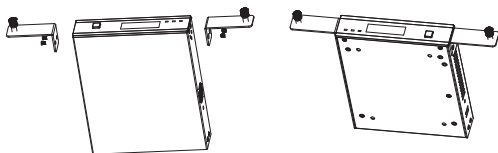

**Step 2:** Simply screw them in vertically in a 6U V2 rack as shown in the figure below:

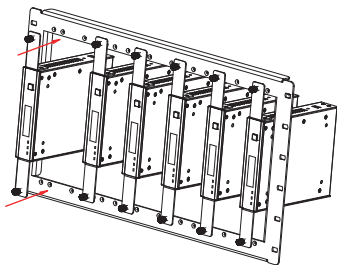

# Rack Mounting Instruction

DONE!

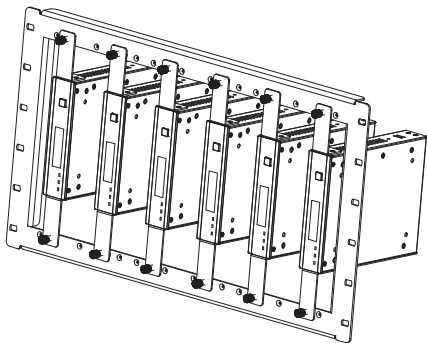

## 1U V2 Rack Mounting

This product also can be mounted in a standard 1U V2 rack (up to 2 units can be installed horizontally). The mounting steps are as follows:

**Step 1:** Use included screws to fix two 1U V2 rack panels on the product, then fix the rack panels to the 1U V2 brackets, as shown in the figure below:

# Rack Mounting Instruction

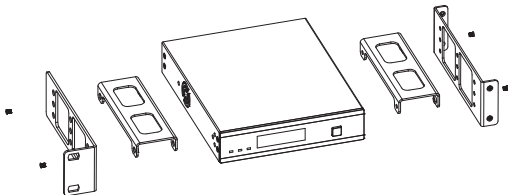

**Step 2:** Fix two rack panels and two brackets on the other unit the same way, then fasten screws between two 1U V2 brackets, so that the two products are mounted in a 1U V2 rack, as shown in the figure below:

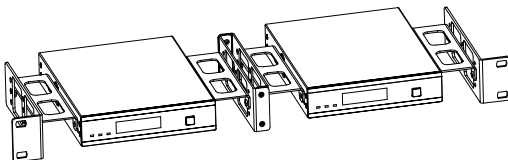

# Stream Service Introduction

## Platform Building

This AV Streamer supports RTSP/RTMP/RTMPS streaming over the network. Follow the steps below to set up the streaming platform:

**Step 1:** Connect the AV Streamer to your signal source, TV, and any audio input/output devices. Then connect the AV Streamer, PC, router, and TV app device to the same 1G network switch (as shown in the diagram).

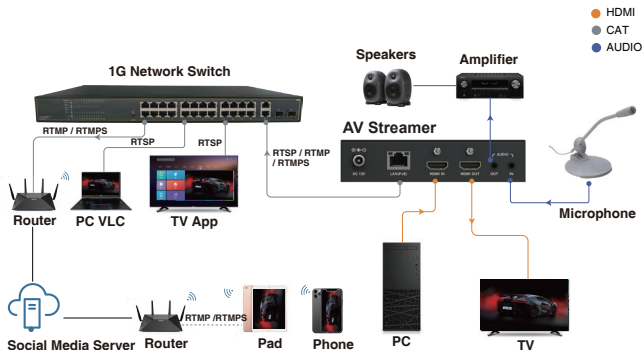

# Platform Building

**Step 2:** Power on the AV Streamer. Press the MENU button on the front panel to navigate to the IP Address page on the OLED screen. The current IP address will display as 192.168.10.80.  
Note: The default IP address is 169.254.1.11.

**Step 3:** Configure the PC's IP address so that it is in the same network segment as the AV Streamer.

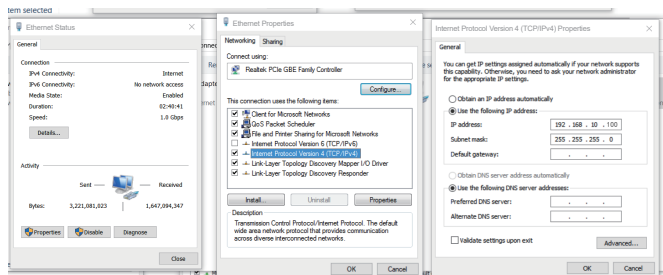

**Step 4:** Open a web browser on the PC, enter the AV Streamer's current IP address (192.168.10.80) into the browser's address bar, and press Enter to access the Web GUI.

# WebGUI Operation

Before accessing the AV Streamer's built-in Web GUI, a login page will appear.

The available usernames are admin and user.

Default password for admin: admin

Default password for user: 123456

Enter the username and password, choose your preferred language, and click "Login" to proceed to the Web GUI.

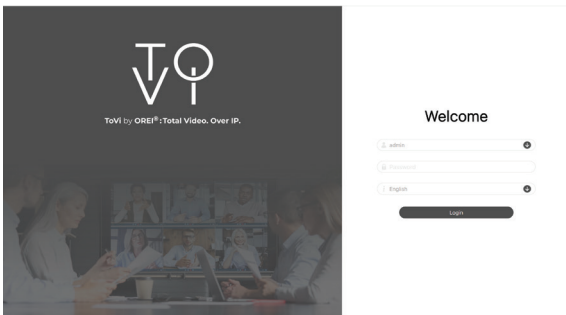

## Status

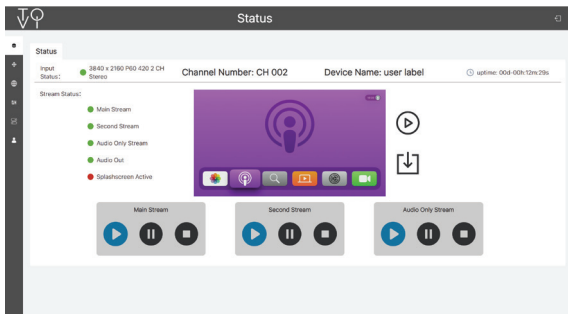

- ① **Input Status:** Displays the current status and details of the incoming signal. A green indicator means a valid signal is detected, and it will show the audio/video format (e.g., 1080P60, dual-channel stereo). A red indicator with "No Signal" means no input source is currently detected.
- ② **Channel Number:** Shows the assigned channel number of the device. In the example above, the device is set to Channel 005.
- ③ **Device Name:** Displays the custom or default name assigned to the device.
- ④ **Uptime:** Shows how long the device has been running continuously since the last boot.
- ⑤ **Stream Status:** Indicates the status of each available output stream:

# WebGUI Operation

## **Main Stream:**

Red - STOP

Orange - PAUSE

Green - ACTIVE

## **Second Stream:**

Red - STOP

Orange - PAUSE

Green - ACTIVE

## **Audio Only Stream:**

Red - STOP

Orange - PAUSE

Green - ACTIVE

## **Audio Out:**

Green - Audio output active

Red - No audio output

## **Splashscreen Active:**

Green - Splashscreen is being displayed on the main stream

Red - Splashscreen is not displayed

⑥ **Stream control buttons** (please refer to point ⑤ for status display)

## **Main Stream:**

Use the ACTIVE, PAUSE, or STOP buttons to start, pause, or stop the main stream.

## **Second Stream:**

Use ACTIVE, PAUSE, or STOP to control the second stream.

## **Audio Only Stream:**

Use ACTIVE, PAUSE, or STOP to manage the audio-only stream.

# WebGUI Operation

## ⑦ Image Capture:

A: Displays the most recently captured image.

B: Press Freeze to refresh the captured image at 5 Hz.

C: Press Download Picture to save the captured image to your computer.

⑧ **Logout button.** Click this button to safely exit the Web GUI.

## Encoder

The screenshot shows the 'Encoder' configuration page. It is divided into several sections: Main Encoding Setting, Second Encoding Setting, Audio Setting, and Stream Multicast Setting. Each section contains various dropdown menus and input fields for configuring video and audio parameters.

Section	Parameter	Value	Range/Options
Main Encoding Setting	Encoding Type	H264	
	Encoding Resolution	Same as Input	
	Frame Rate(fps)	60	[5-60]
	GOP	60	[5-300]
	Bitrate Control	CBR	
Second Encoding Setting	Encoding Resolution	1024x1080	
	Frame Rate(fps)	30	[5-30]
	GOP	60	[5-300]
	Bitrate Control	VBR	
	Bitrate(kbit)	10000	[10-32000]
Audio Setting	Audio Encoding	PCM	
	Audio Source	HD30	
Stream Multicast Setting	Channel Number	2	Available
	Main Stream RTP Multicast IP	224.1.100.2	
	Main Stream TS Multicast IP	224.3.100.2	
	Second Stream RTP Multicast IP	224.2.100.2	
	Second Stream TS Multicast IP	224.4.100.2	

## ① Main Encoding Setting:

**Encoding Type:** Select the encoding format (H.264 or H.265). This option is exclusive to the main stream.

# WebGUI Operation

**Encoding Resolution:** Choose from Same as input, 3840×2160, 1920×1080, 1280×720, or 640×480. Same as input and 3840×2160 are available only for the main stream. Same as input sets the output resolution to match the incoming signal.

**Frame Rate(Hz):** Sets the encoding frame rate.

**GOP:** Defines the Group of Pictures interval (distance between I-frames).

**Bitrate Control:** Choose VBR (Variable Bitrate) or CBR (Constant Bitrate).

**Bitrate(kbit):** Enter the target bitrate.

Level: The main stream supports Baseline level only.

## ② Second Encoding Setting

**Encoding Resolution:** Select from 1920×1080, 1280×720, or 640×480.

**Frame Rate(Hz):** Set the encoding frame rate.

**GOP:** Defines the interval between I-frames.

**Bitrate Control:** Choose between VBR or CBR.

**Bitrate(kbit):** Enter the target bitrate.

**H264 Level:** Supports Baseline, Main, and High levels.

## ③ Audio Setting

**Audio Encoding:** Displays the audio encoding format (read-only).

**Sample Frequency(kHz):** Shows the audio sampling frequency (read-only).

**Audio Source:** Select the audio input source for encoding—HDMI or Analog.

# WebGUI Operation

The screenshot shows the 'Encoder' web interface with the 'Stream Multicast Setting' tab selected. The interface is organized into several sections:

- Stream Multicast Setting:** Includes a 'Channel Number' field set to '2' with a green dot and 'Available' status. Below are fields for 'Main Stream RTSP Multicast IP' (224.1.0.0.2), 'Main Stream TS Multicast IP' (224.3.100.2), 'Audio Only Multicast IP' (224.5.100.2), 'Second Stream RTSP Multicast IP' (224.2.100.2), and 'Second Stream TS Multicast IP' (224.4.100.2).
- RTSP Unicast Stream Setting:** Features a dropdown menu set to 'Enable'. It includes 'Main Stream RTSP Unicast URL' and 'Second Stream RTSP Unicast URL' fields, both containing RTSP URLs and a 'Copy' button.
- RTSP Multicast Stream Setting:** Features a dropdown menu set to 'Disable'. It includes 'RTSP Multicast Port' (5004) with a range indicator [2-65535], 'Main Stream RTSP Multicast URL', and 'Second Stream RTSP Multicast URL' fields, each with a 'Copy' button.
- TS Multicast Stream Setting:** Features a dropdown menu set to 'Disable'. It includes 'TS Multicast Port' (5002) with a range indicator [1-65535] and a 'Main Stream TS Multicast URL' field with a 'Copy' button.

## ④ Stream Multicast Setting

**Channel Number:** Sets the stream's broadcast channel number.

Green dot: Channel available

Red dot: Channel unavailable (likely due to conflict with another device using the same channel)

**Multicast IP addresses:**

Automatically assigned based on the channel number (read-only).

## ⑤ RTSP Unicast Stream Setting

**RTSP Unicast Stream:** Use the dropdown to enable or disable RTSP unicast streaming.

**Main Stream RTSP Unicast URL:** The RTSP address for the main stream. When enabled, click Copy to use the URL in a media player.

**Second Stream RTSP Unicast URL:** The RTSP address for the second stream. When enabled, click Copy to play it in a media player.

# WebGUI Operation

## ⑥ RTSP Multicast Stream Setting

**RTSP Multicast Stream:** Enable/disable RTSP multicast streaming.

**RTSP Multicast Port:** Sets the port used for multicast (applies to both streams).

**Main Stream RTSP Multicast URL:** Click Copy to use the URL in a media player.

**Second Stream RTSP Multicast URL:** Click Copy for the second stream multicast URL.

## ⑦ TS Multicast Stream Setting

**TS Multicast Stream:** Enable/disable TS multicast streaming.

**TS Multicast Port:** Set the multicast port for both streams..

**Main Stream TS Multicast URL:** Click Copy for playback in a media player.

**Second Stream TS Multicast URL:** Click Copy to use the second stream TS multicast link.

## ⑧ Audio Only Multicast Stream Setting

**Audio Only Multicast Stream:** Enable/disable audio-only multicast output.

**Audio Only Multicast Port:** Set the multicast port for audio-only streaming.

**Audio Only Multicast URL:** The multicast address for audio-only output. Once enabled, you can play it using compatible software such as VLC.

# WebGUI Operation

The screenshot shows the 'Encoder' web interface with the following settings:

- TS Multicast Stream Setting:**
  - TS Multicast Stream: Disabled
  - TS Multicast Port: 8002 [2-65535]
  - Main Stream TS Multicast URL: rtp://224.0.0.2:8002 [Copy]
  - Second Stream TS Multicast URL: rtp://224.0.0.2:8002 [Copy]
- Audio Only Multicast Stream Setting:**
  - Audio Only Multicast Stream: Disabled
  - Audio Only Multicast Port: 8006 [2-65535]
  - Audio Only Multicast URL: rtp://224.0.0.2:8006 [Copy]
- RTMP/RTMPS Push Stream Setting:**
  - Main RTMP/RTMPS Stream: Enabled
  - Main RTMP/RTMPS Push URL: rtmp://192.168.254.1:1935/live/stream [Connected]
  - Second RTMP/RTMPS Stream: Disabled
  - Second RTMP/RTMPS Push URL: rtmp://192.168.1.100/live/stream [Not Connected]
- System Mode Setting:**
  - Closed System Mode: On

An 'Apply' button is located at the bottom center of the configuration area.

## ⑨ RTMP/RTMPS Push Stream Setting

**Main RTMP/RTMPS Stream:** Enable or disable main stream RTMP/RTMPS output.

**Main RTMP/RTMPS Push URL:** Enter the streaming server URL. Streaming starts only when Enable is selected. Red dot: Push failed or inactive. Green dot: Push stream is active

**Second RTMP/RTMPS Stream:** Enable/disable the second stream's push output.

**Second RTMP/RTMPS Push URL:** Enter the URL for the second stream push. Same status rules apply (red = failed, green = active).

After configuring encoding settings, stream options, channel assignments, and audio settings, click Apply to save and activate the changes.

# WebGUI Operation

## Network

The screenshot shows the 'Network' configuration page. It includes the following sections and fields:

- LAN Setting:** IP Mode (DHCP), IP Address (192.168.1.11), Subnet Mask (255.255.0.0), Gateway (192.168.1.1), and MAC Address (8C:4F:76:03:89:7C).
- DNS Setting:** Preferred DNS (192.168.1.1) and Alternate DNS (192.168.1.1).
- HTTPS Setting:** HTTPS (OFF).
- NTP Server Setting:** NTP Server (pool.ntp.org) and NTP Port (123). NTP Status is 'Unreachable'.
- 802.1x Setting:** 802.1x (OFF) and 802.1x Password.

Buttons at the bottom include 'Get Network Defaults' and 'Apply'.

### ① LAN Setting

Select the IP Mode (DHCP or Static).

**Static:** Allows manual configuration of the IP Address, Subnet Mask, and Gateway. After entering the values, click Apply for the settings to take effect. **DHCP:** The network parameters are automatically assigned by the router or another DHCP server.

### ② DNS Setting

Displays the Preferred DNS and Alternate DNS server addresses. These fields are read-only.

### ③ HTTPS Setting

The system uses HTTP for login by default. Switching this option to ON enables HTTPS. The device will automatically reboot when switching between HTTP and HTTPS modes.

## ④ NTP Server Setting

**NTP Server:** Enter the NTP server address.

**NTP Port:** The access port used for NTP communication.

**NTP Status:** Shows the connection status to the NTP server:

Green dot: Successfully connected

Red dot: Connection failed

## ⑤ 802.1x Setting

**802.1x:** Use the dropdown menu to enable or disable 802.1x authentication.

**802.1x User:** The authentication username.

**802.1x Password:** The authentication password

**Set Network Defaults:** Restores all network settings to factory default values.

**Apply:** Saves and activates the configured network settings. If not applied, changes will not take effect.

# WebGUI Operation

## System

The screenshot shows a web interface for system configuration. The main title is 'System'. The interface is organized into several sections:

- Device Name Setting:** A text input field labeled 'Device Name' with a placeholder 'User Label' and an 'Apply' button.
- OSD Setting:** Two input fields for 'X' and 'Y' coordinates, an 'OSD Text' input field, and 'Apply' and 'Clear OSD' buttons.
- Fan Speed Setting:** A dropdown menu labeled 'Fan Speed' with a placeholder 'Low Speed'.
- Front Panel Menu Button Lock:** A dropdown menu labeled 'Menu Button Lock' with a placeholder 'Enable'.
- Configuration:** A section with a 'Select File' button, a 'No file' label, and 'Load' and 'Save' buttons.
- Appearance:** A section with a checked 'Screen Screen Active' checkbox and a 'Screen Screen Update' dropdown menu with a 'No file' label and an 'Update' button.

① **Device Name Setting:** Allows you to modify the device name. Enter the new name and click Apply for the change to take effect.

### ② OSD Setting

**X:** Sets the horizontal position of the OSD, starting from the top-left corner and moving left to right.

**Y:** Sets the vertical position of the OSD, starting from the top-left corner and moving top to bottom.

**OSD Text:** Enter the text you want displayed on-screen and click Apply to activate the OSD. Click Clear OSD to remove the on-screen display.

### ③ Fan Speed Setting

**Fan Speed:** Select the desired fan speed from the dropdown menu: Silent / Low Speed / Standard Speed / High Speed

## ④ Front Panel Menu Button Lock

**Menu Button Lock:** Use the dropdown menu to Enable or Disable the MENU button on the front panel.

## ⑤ Configuration

**Download configuration:** Click Save to export the current device configuration to your computer.

**Upload configuration:** Click Select File to choose a configuration file, then click Load to import it.

## ⑥ Splashscreen

**Splash Screen Active:** Indicates whether a splash screen image has been uploaded.

Gray dot: No image uploaded.

Green dot: Image successfully uploaded

**Splash Screen Update:** Click Select File to choose an image, then click Update to upload it.

## ⑦ EDID Setting

**Select EDID:** Choose the desired EDID profile from the dropdown menu.

**Upload EDID to User:** Click Select File to import a custom EDID file (256-byte binary format), then click Load.

**Note:** To use a custom EDID, upload the file first and then select User EDID from the EDID list.

# WebGUI Operation

## ⑧ Firmware

**Firmware Version:** Displays the current firmware version.

**Firmware Update:** Click Select File to choose the firmware package, then click Update to begin the upgrade.

**Reboot:** Restarts the device.

**Reset:** Restores the device to factory default settings.

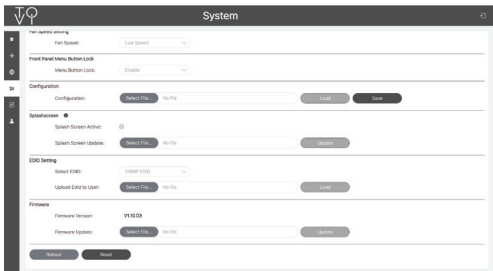

## Device List

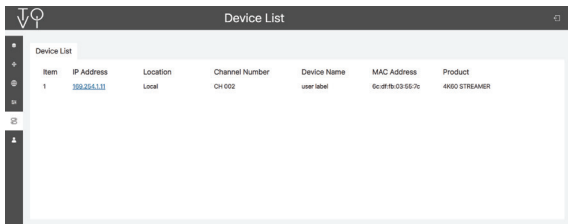

The screenshot shows a web browser window titled "Device List". The page contains a table with the following data:

Item	IP Address	Location	Channel Number	Device Name	MAC Address	Product
1	<a href="#">199.254.1.11</a>	Local	CH 002	user label	6c:d7:fb:03:66:7c	4K60 STREAMER

This page shows all AV Streamer devices detected on the network, along with their key information:

**IP Address:** Displays the current IP address assigned to the device.

**Location:** Indicates whether the device is on the local network or a remote network.

**Channel Number:** Shows the channel number assigned to the device. If two devices share the same channel number, both will be highlighted in red to indicate a conflict.

**Device Name:** Displays the name assigned to the device.

**MAC Address:** Shows the unique MAC address of the device.

**Product:** Lists the specific product model.

# WebGUI Operation

## Admin

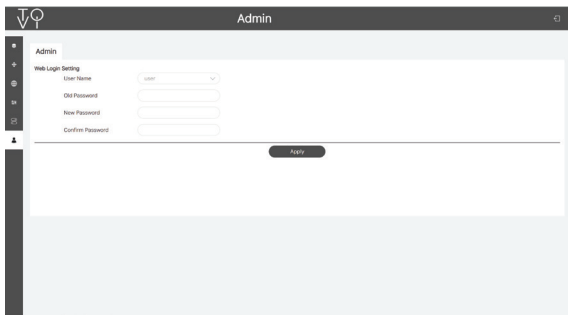

The screenshot shows a web browser window titled "Admin". On the left is a dark sidebar with navigation icons. The main content area is titled "Admin" and contains a "Web Login Setting" section. This section includes a dropdown menu for "User Name" (set to "user"), and three text input fields for "Old Password", "New Password", and "Confirm Password". Below these fields is a dark "Apply" button. The bottom half of the browser window is a light gray area, likely representing a footer or additional content.

You can change the Web login password for both the admin and user accounts. Enter the old password, then the new password, confirm it, and click “Apply” to save the changes.

# RTSP/TS Stream Operation

This AV Streamer supports playing RTSP/TS stream on computer through the corresponding software such as VLC media player, simultaneously you can access the build-in Web GUI to configure the stream.

The operation steps show as below.

**Step 1:** Enable the RTSP/TS stream on the Encoder page of the Web GUI, as shown in the figure below.

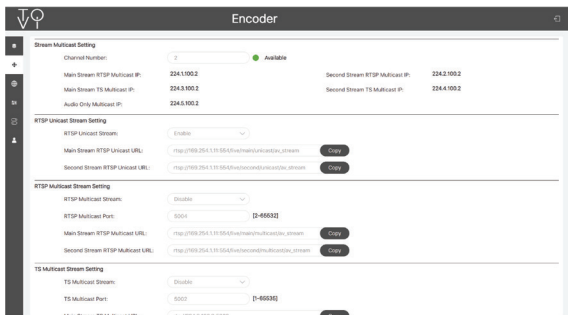

**Step 2:** Click the "Copy" button behind the RTSP/TS stream to be played to copy the stream URL.

**Step 3:** Install the VLC media player software (<https://www.videolan.org/>) on PC.

**Step 4:** After successful installation, open the VLC media player on PC.

# RTSP/TS Stream Operation

**Step 5:** Click “Media > Open Network Stream”.

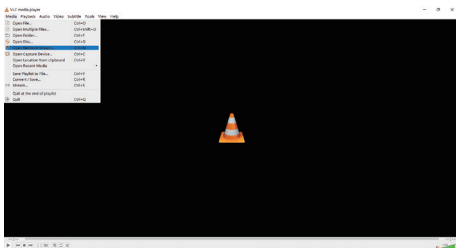

After clicking the “Open Network Stream” option, the Open Media window will pop up. Paste the RTSP/TS stream URL into the URL input box, then click the “Play” button to start playing stream.

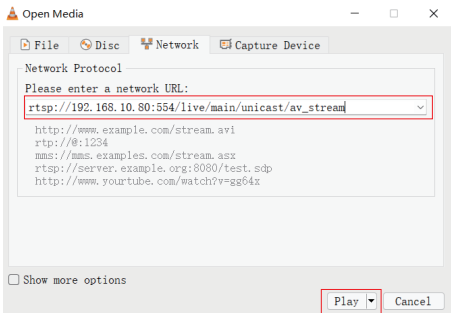

# RTSP/TS Stream Operation

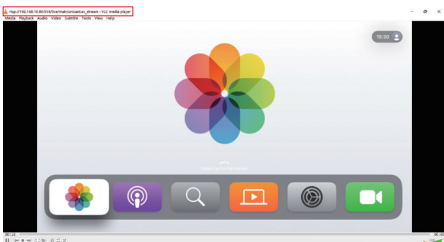

On VLC media player, you can view the TS/RTSP stream settings that are configured on the “Encoder Page” (for details, please refer to “7.2 Web GUI Operation”). Choose “Tools > Codec Information” to display the stream information in the pop-up window as shown below.



Choose “Tools>Codec Information>Statistics” to check the current bitrate. Please see the following picture.

# RTSP/TS Stream Operation

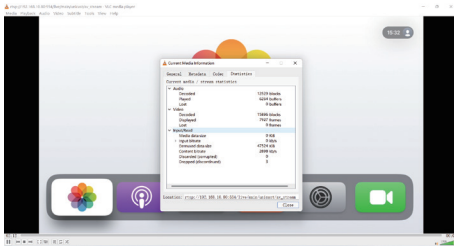

Note: The bitrate is floating up and down when you check it. This is a normal phenomenon.

# RTMP/RTMPS Push Stream (Youtube) Operation

This AV Streamer supports RTMP/RTMPS push stream on computer through the corresponding website such as Youtube, simultaneously you can access the build-in Web GUI to configure the push stream. The operation steps show as below.

**Step 1:** Login to <https://www.youtube.com/> and click on the create icon to start uploading.

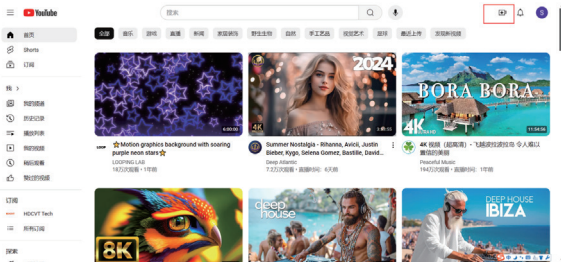

**Step 2:** Obtain the URL of the RTMP/RTMPS push stream.

RTMP is used by default, according to the following information, the RTMP push stream URL is `rtmp://a.rtmp.youtube.com/live2/589x-m3g8-cw98-hrcp-a34k`

# RTMP/RTMPS Push Stream (Youtube) Operation

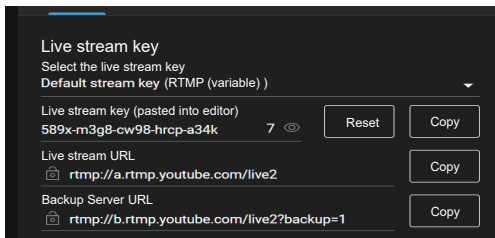

Live stream key  
Select the live stream key  
Default stream key (RTMP (variable))

Live stream key (pasted into editor)  
589x-m3g8-cw98-hrcp-a34k 7 

Live stream URL  
 `rtmp://a.rtmp.youtube.com/live2`

Backup Server URL  
 `rtmp://b.rtmp.youtube.com/live2?backup=1`

Click the icon  to obtain the URL of the RTMPS push stream, according to the following information, the RTMPS push stream URL is `rtmps://a.rtmps.youtube.com/live2/589x-m3g8-cw98-hrcp-a34k`

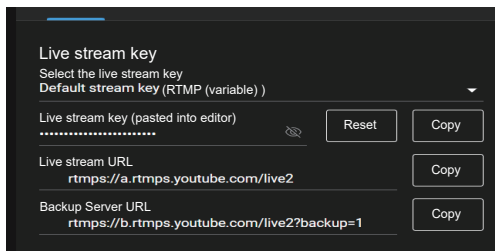

Live stream key  
Select the live stream key  
Default stream key (RTMP (variable))

Live stream key (pasted into editor)  
..... 

Live stream URL  
`rtmps://a.rtmps.youtube.com/live2`

Backup Server URL  
`rtmps://b.rtmps.youtube.com/live2?backup=1`

**Step 3:** Start the push stream.

Fill in the Main RTMP/RTMPS PUSH URL with the push stream URL and enable it by selecting "Enable" from the drop-down menu.

# RTMP/RTMPS Push Stream (Youtube) Operation

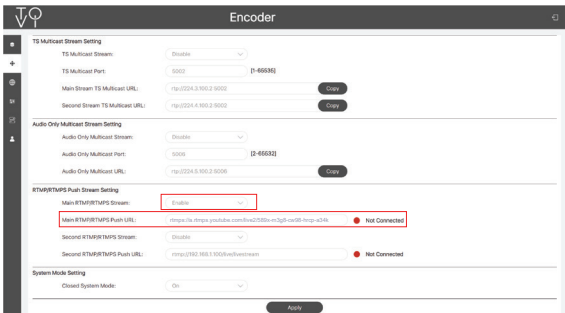

Manually refresh the page and wait for the red dot to turn into a green dot, indicating that the push stream is successful.

# Audio Only Stream Operation

This AV Streamer supports playing audio only multicast stream on computer through the corresponding software such as VLC media player, and you can simultaneously access the build-in Web GUI to configure the stream.

The operation steps show as below.

**Step 1:** Enable the Audio Only Multicast Stream on the Encoder page of the Web GUI, as shown in the figure below.

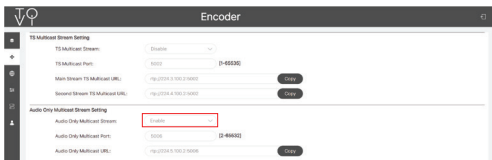

**Step 2:** Open a serial command tool on PC, as shown in the figure below, input the Module IP (192.168.10.80) of the device, and the Port (8000), then click "Connect" to connect with the device.

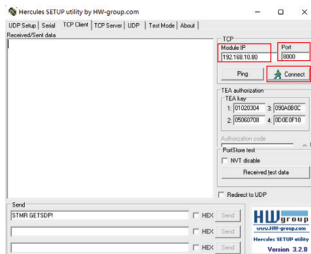

# Audio Only Stream Operation

**Step 3:** Input the command “STMR GETSDP!” and click “Send”, then you will get the feedback, as shown in the figure below.

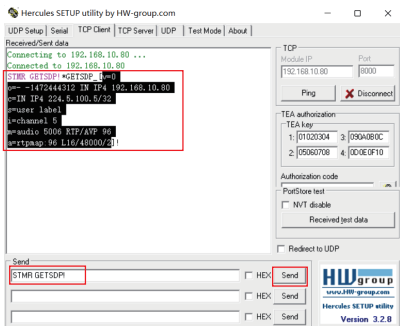

**Step 4:** Copy the obtained configuration file (selected part in the figure above), then paste it in the new-created notepad (or directly overwrite the content of the provided RTP\_AUDIO-STREAM-PCM.sdp file). Finally, save the file with the name of “RTP\_AUDIO-STREAM-PCM.sdp”, as shown below.

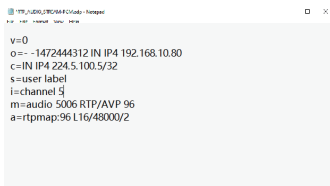

# Audio Only Stream Operation

**Step 5:** Open the VLC media player on PC, click “Media > Open File” to import the sdp file, then the audio only multicast stream will start to play.

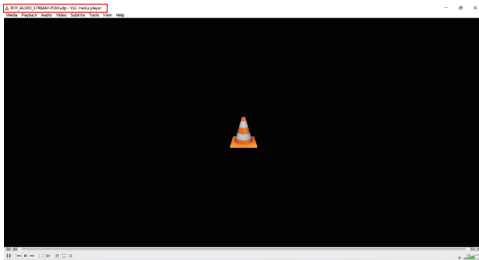
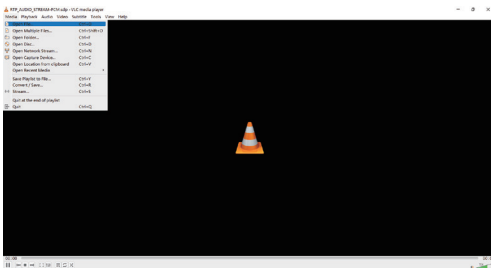

# Application Example

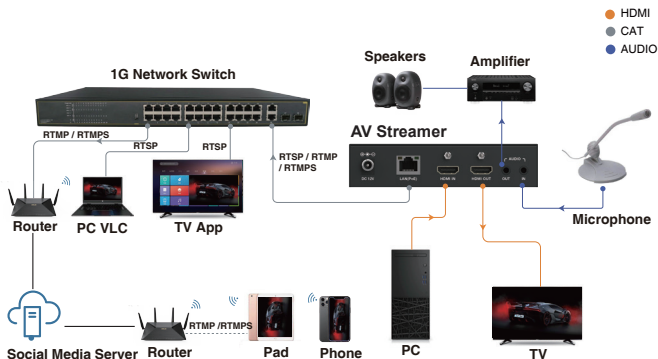

**HDMI**<sup>TM</sup>  
HIGH-DEFINITION MULTIMEDIA INTERFACE

The terms HDMI, HDMI High-Definition Multimedia Interface, HDMI trade dress and the HDMI Logos are trademarks or registered trademarks of HDMI Licensing Administrator, Inc.

# FAQs & Troubleshooting

## 1. Does the X2UH-CAST require a controller from the X2 Series?

No. It works independently as a standalone network streamer. However, it is fully compatible with the ToVi X2 Series and can be discovered and managed (limited control) through the X2UH-CB control box.

## 2. Device is not appearing on the network

- Ensure your switch supports 802.3af PoE or use the included power adapter to power the device.
  - Check if DHCP is enabled. If using Static IP, confirm subnet/gateway are correct.
  - Verify that multicast/unicast traffic is allowed.

## 3. No video output on the stream

- Confirm HDMI source is active and outputting a supported resolution.
  - Try changing the EDID setting under System -> EDID.
- Check if the streaming protocol (RTSP/RTP/RTMP) is correctly configured.
- Try accessing the lower-resolution preview stream (1080p or 720p) to verify functionality.

## 4. RTMP stream is not connecting to YouTube/Facebook

- Make sure you are using the correct Server URL and Stream Key.
  - Enable RTMPS if the platform requires secure streaming.
  - Ensure your network/firewall allows outbound RTMP traffic.
    - Reduce bitrate if your upload speed is limited.

# FAQs & Troubleshooting

## 5. Cannot log into the Web GUI

- Make sure your laptop/pc IP address is in the same segment as the Streamer.
  - Use HTTPS to login.
- Press and Hold the MENU button on the front for 10 seconds to restore the unit to factory settings and try logging in with the default IP address.

### ***Still have some questions?***

Please feel free to contact us at: [info@orei.com](mailto:info@orei.com). OR Fill out the form on the 'Contact Us' page on the website.

Our team will be more than happy to help you.

### **OREI Live Technical Support Hours**

US team (US/Canada/Mexico): Monday-Friday, 9 a.m. - 5 p.m. Central Time  
**Support Email** - [info@orei.com](mailto:info@orei.com) | **Support Number** - 877-290-5530



**X2 Series (4K) Network  
Video Streamer**

**X2UH-CAST**

*[www.orei.com](http://www.orei.com)*

© 2025