

IP POWER AMPLIFIER**IP-A1PA12**

Thank you for purchasing TOA's IP Power Amplifier.
Please carefully follow the instructions in this manual to ensure long, trouble-free use of your equipment.

TABLE OF CONTENTS

1. SAFETY PRECAUTIONS	2
2. SUMMARY AND FEATURES	4
3. ABOUT SECURITY MEASURES	4
4. SYSTEM EXAMPLE	5
4.1. SIP Broadcasting/Two-way Communication	5
4.2. VMS Broadcast System	5
4.3. Linked External Amplifier Broadcast System	5
5. DIMENSIONAL DRAWINGS	6
6. NOMENCLATURE AND FUNCTIONS	7
Front	7
Rear	7
Bottom	9
7. HANDLING PRECAUTIONS	9
8. UNIT MOUNTING	10
9. CONNECTIONS	11
9.1. Network Connection	11
9.2. Connections to Speaker Output and External AMP Input Terminals	11
9.3. Connections to LINE/MIC Input and Line Output Terminals	12
9.4. Connections to Control Input, Control Output, and Mute Terminals	14
9.5. Removable Terminal Plug Connections	15
10. SETTINGS	16
10.1. System Settings Summary	16
10.2. System Requirements	17
10.3. Connection with Browser	17
11. INITIALIZATION OF SETTINGS	18
12. CAUTIONS REGARDING THE AVC/H.264 PATENT LICENSE	19
13. OPEN SOURCE SOFTWARE	19
14. ACCESSORIES	19

1. SAFETY PRECAUTIONS

- Before installation or use, be sure to carefully read all the instructions in this section for correct and safe operation.
- Be sure to follow all the precautionary instructions in this section, which contain important warnings and/or cautions regarding safety.
- After reading, keep this manual handy for future reference.



WARNING Indicates a potentially hazardous situation which, if mishandled, could result in death or serious personal injury.



CAUTION Indicates a potentially hazardous situation which, if mishandled, could result in moderate or minor personal injury, and/or property damage.



WARNING

- Do not touch the unit and LAN cable during thunder and lightning, as this may result in electric shock.

- To prevent the electromagnetic wave from badly influencing medical equipment, make sure to switch off the unit's power when placing it in close proximity to the medical equipment.

When Installing the Unit

- Do not expose the unit to rain or an environment where it may be splashed by water or other liquids, as doing so may result in fire or electric shock.

When the Unit is in Use

- Should the following irregularity be found during use, immediately cut off the power supply from a PoE+ switching hub and contact your nearest TOA dealer. Make no further attempt to operate the speaker in this condition as this may cause fire or electric shock.
 - If you detect smoke or a strange smell coming from the unit
 - If water or any metallic object gets into the unit
 - If the unit falls, or the unit case breaks
 - If the LAN cable is damaged (exposure of the core, disconnection, etc.)
 - If the speaker suddenly stops producing sound
- To prevent a fire or electric shock, never open nor remove the unit case as there are high voltage components inside the unit. Refer all servicing to qualified service personnel.



CAUTION

When Installing the Unit

- Avoid installing the unit in humid or dusty locations, in locations exposed to the direct sunlight, near the heaters, or in locations generating sooty smoke or steam as doing otherwise may result in fire or electric shock.
- Avoid touching the unit's sharp metal edge to prevent injury.
- To avoid electric shocks, be sure to switch off the unit's power when connecting speakers.
- Be sure to follow the instructions below when rack-mounting the unit. Failure to do so may cause a fire or personal injury.
 - Install the equipment rack on a stable, hard floor. Fix it with anchor bolts or take other arrangements to prevent it from falling down.

- When connecting the unit's power cord to an AC outlet, use the AC outlet with current capacity allowable to the unit.
- Use the optional MB-15B-BK Half Width Blank Panel to rack-mount the unit.
- The rack-mounting screws supplied with the MB-15B-BK can be used for the TOA equipment rack only. Do not use them for other racks.



The IP-A1PA12 IP Power Amplifier is capable of delivering extremely high volume sound output. Therefore, close proximity to the unit over time could present the danger of hearing impairment. Be sure to follow the instructions below when conducting performance tests:

- Turn down the sound volume before adjusting the volume.
- Do not position one's ear close to the speaker.
- Point the unit in a direction where no people are present.
- Avoid listening to high-volume output for prolonged periods of time.

FCC REQUIREMENTS

Note

This equipment has been tested and found to comply with the limits for a Class A digital device, pursuant to Part 15 of the FCC Rules. These limits are designed to provide reasonable protection against harmful interference when the equipment is operated in a commercial environment. This equipment generates, uses, and can radiate radio frequency energy and, if not installed and used in accordance with the instruction manual, may cause harmful interference to radio communications.

Operation of this equipment in a residential area is likely to cause harmful interference in which case the user will be required to correct the interference at his own expense.

Modifications

Any modifications made to this device that are not approved by TOA Corporation may void the authority granted to the user by the FCC to operate this equipment.

DECLARATION

Any modification to the unit, unless expressly approved by TOA Electronics, Inc., could void your authority to operate the equipment.

DECLARATION OF CONFORMITY

TOA Electronics, Inc.

1 Harmon Plaza, Suite 700 Secaucus, New Jersey 07094, USA

TEL 650-452-1200

declares under its sole responsibility that the product

IP POWER AMPLIFIER 12W IP-A1PA12

complies with Part 15 of FCC Rules.

Operation is subject to the following conditions: (1) this device may not cause harmful interference, and (2) this device must accept any interference received, including interference that may cause undesired operation.

Warning: Operation of this equipment in a residential environment could cause radio interference.

This equipment is not suitable for use in locations where children may be present.

2. SUMMARY AND FEATURES

The IP-A1PA12 is an IP Power Amplifier which decodes IP audio streams into analog signals. It is equipped with a built-in 12 W amplifier to drive High-impedance speaker(s). Analog audio and control outputs can be connected to an external amplifier for scaling up the system capability.

- Power is supplied by way of PoE+ (IEEE 802.3at) switching hubs.
- The IP Power Amplifier is compatible with the following broadcasting modes:

Internal sound source broadcasting mode	Enables broadcast of up to 20 internal sound source files by means of control input or Remote API (HTTP/HTTPS).
VMS broadcasting mode	Enables backchannel audio broadcast from the VMS (Video management system) software using the common protocol for IP cameras.
SIP broadcasting mode	Enables SIP broadcasts from any voice communications device that utilizes the SIP protocol, such as SIP or IP telephone (IP-PBX) systems.
Multicast broadcasting mode	Allows up to 20 multicast ports to be set up, for 20 multicast audio stream paging groups.
Local broadcasting mode	Local broadcasting mode enables broadcast locally to the speaker output from the sound source device or microphone connected with LINE/MIC input.

- Orders of priority can be set among the various broadcasting modes, meaning higher priority broadcasts can interrupt and override lower priority broadcasts.
- Since the unit is equipped with individual offset adjustable volumes for each broadcasting modes and patterns (internal sound source), actual broadcasting volume can be normalized or optimized.
- Broadcasts can be controlled using Remote API or control inputs from connected external equipment.
- Connected external equipment can be controlled by control outputs in synchronization with speaker broadcasts.
- This unit can be connected to an external amplifier and can broadcast from an external amplifier to a speaker line connected to this unit. It is possible to build a system that can broadcast from the network by sharing a speaker line of an existing PA system.

3. ABOUT SECURITY MEASURES

- Ensure that sufficient security measures are taken on the customer's own responsibility.
- TOA Corporation takes no responsibility for damage or loss caused by security-related problems, such as illegal access.
- To help prevent illegal access to the unit, be sure to change the user ID and password from those used for initial setup. For setting methods and other details, please refer to the separate receiving device setup manual which can be downloaded from the TOA DATA Library (<https://www.toa-products.com/international/>).
- Take utmost care in the management of the unit's communications password.

4. SYSTEM EXAMPLE

4.1. SIP Broadcasting/Two-way Communication

SIP phone conversations possible using a microphone and a speaker connected to the unit.

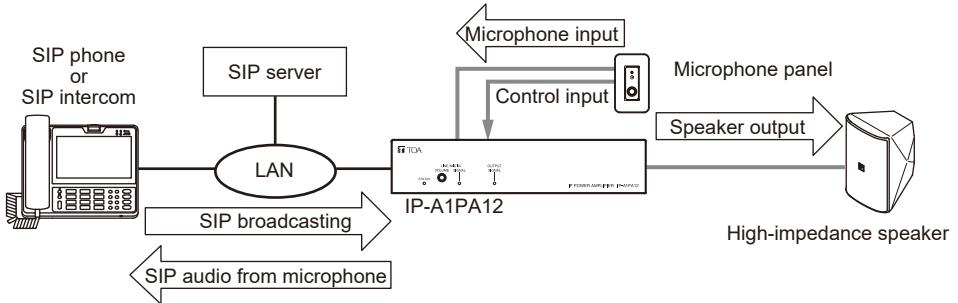

Tips

- Set the local broadcasting settings "OFF." If it is "ON," the microphone input voice will not be output as SIP call from microphone.
- When the voice switch setting is "ON," the call will be half-duplex.

4.2. VMS Broadcast System

VMS software broadcasts can be performed to speakers connected with the unit. An external microphone can also be connected for monitoring audio in the field.

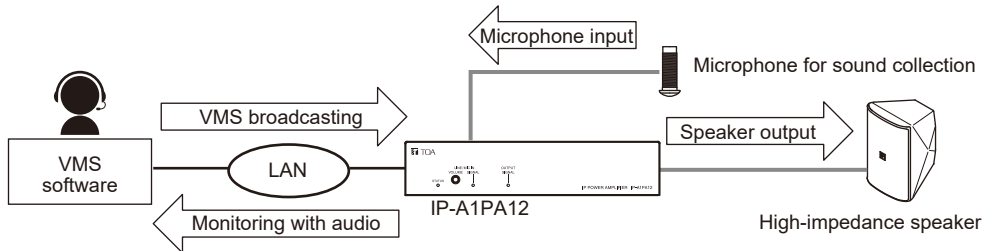

Tip

Set the local broadcasting settings "OFF." If it is "ON," the microphone input voice will not be output as monitoring audio.

4.3. Linked External Amplifier Broadcast System

The speaker line connected to this unit can be shared with an external amplifier for broadcasting from the external amplifier.

By connecting a speaker line and control signal of existing PA system to this unit, it is possible to build a system that combines an analog PA system and a network PA system.

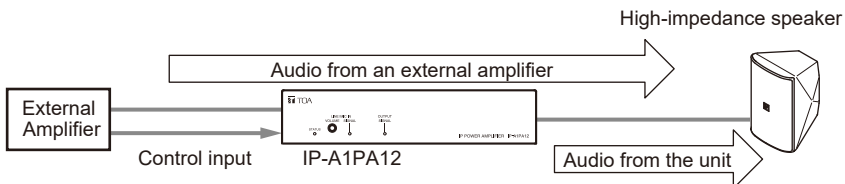

5. DIMENSIONAL DRAWINGS

Unit: mm (in)

[Front]

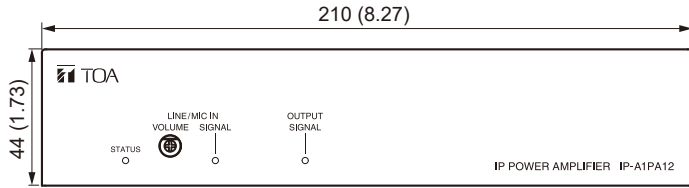

[Rear]

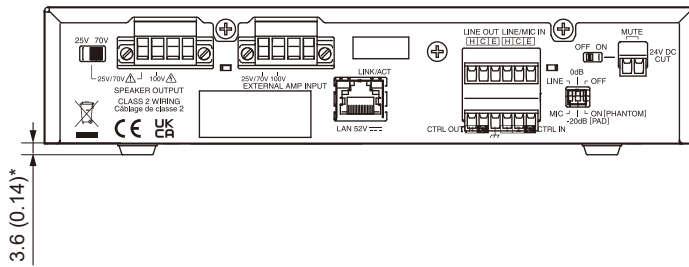

[Side]

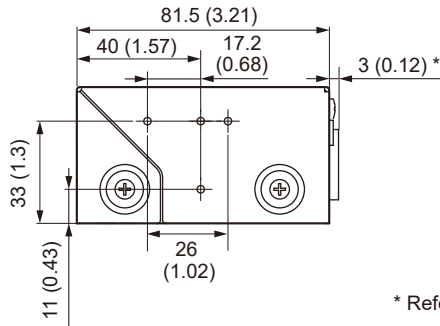

* Reference dimension

6. NOMENCLATURE AND FUNCTIONS

[Front]

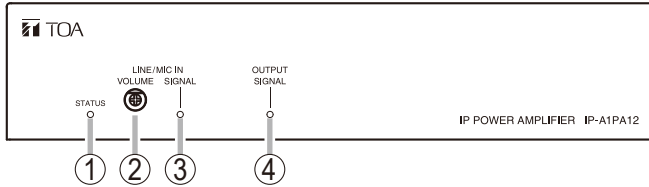

- 1. Status indicator (green, blue, yellow, red)**
Indicates the unit's operating status.

Unit Operation	Status Indicator
System startup	Flashing green
Broadcast standby	Continuously lit green
Broadcasting	Continuously lit blue
System mute*	Flashing red
External Amplifier	Idle: Flashing green Broadcasting: Flashing blue
Initialization or firmware updating	Continuously lit yellow

* System mute is a state in which this unit is muted by the control from the transmitting device.

- 2. LINE/MIC input volume control**
Adjusts the volume level of the LINE/MIC input. Rotate this volume control clockwise to increase the volume level and counterclockwise to decrease it. Set this volume not to make the LINE/MIC input signal indicator (3) light up in red.

- 3. LINE/MIC input signal indicator (green, red)**
Lights green when a signal is input to LINE/MIC input. Lights red when the input signal level is too high.

- 4. Output signal indicator (green)**
Lights green when a signal is outputting from the speaker or line output.

[Rear]

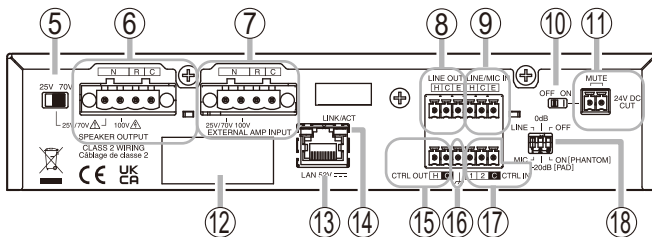

The figure with a removable terminal plug detached.

- 5. 25V/70V selector switch**
Set this switch to match the specifications of speaker being connected to the unit's speaker terminals or the connected external amplifier. Select "70V" if the speaker being connected is a 70 V high-impedance line speaker, or "25V" if it is a 25 V high-impedance line speaker. The switch is set to "70V" by default.

- 6. Speaker output terminals**
Connect only high-impedance speakers. Output specifications are shown in the table on the next page:

Rated Output	12 W	
Compound Impedance	100 V high-impedance line	830 Ω
	70 V high-impedance line	420 Ω
	25 V high-impedance line	52 Ω

Note

To avoid the unit or peripheral device failure, please note the following precautions when connecting speakers.

- The terminals marked with the symbol ⚠ are hazardous live. The external wiring to these terminals requires installation by an instructed person.
- Be sure that power to the unit is turned OFF when connecting speakers.
- Be sure to check speaker specifications to ensure correct connection to the proper terminals.
- Do not connect a speaker that exceeds the rated output.
- Avoid simultaneously connecting both the 100 V high-impedance line and the 25 V/70 V high-impedance line terminals.
- Ensure that the wiring distance to the furthest speaker from the unit is under 500 m or 1640.42 ft (when ø0.9 – 1.6 mm cable is used).

7. External amplifier input terminals

Used to connect a high-impedance speaker line from an external amplifier. Various control functions allow external amplifier output from the speaker connected to the unit.

Note

Please note the following precautions when making connections in order to avoid failure or damage to the unit or peripheral devices.

- Before connecting the external amplifier, always be sure that power to the unit is turned OFF.
- Avoid simultaneously connecting both the 100 V high-impedance line and the 25 V/70 V high-impedance line terminals.

8. Line output terminal

Connects with an external amplifier etc. and outputs the same audio as the speaker output.

9. LINE/MIC input terminal

Connects with a microphone or sound

source device.

This can also be used as an analog audio input when in local broadcasting mode or alternatively as an audio input during SIP calls, or for monitoring VMS broadcast. Adjust with the DIP switch (18) according to the output level of the connected device.

10. Mute setting switch

Switch ON to enable the Mute terminals (11).

Note

Do not switch ON if no connection is made to the Mute terminals (11). Since the unit recognizes the 24 V DC signal from an emergency broadcast as indication of a break state (i.e. the state during which an emergency broadcast is in progress), it will be placed in perpetual MUTE mode, disabling all other types of broadcasts from the unit.

11. Mute terminals (non-polar)

Audio broadcasts from the unit can be forcibly muted by inputting a 24 V DC cut-off signal which also enables the external amplifier through the amplifier switching control. Be sure that the Mute setting switch (10) is turned ON when using these terminals.

12. Name label

Product number, product name, manufacturer name, and other information are listed.

13. LAN port

Connect to a PoE+ switching hub using a LAN cable.

14. LINK/ACT indicator (green)

Flashes when data is being sent or received over a network.

15. Control output terminal

Allows control of external equipment in synchronization with the unit operation.

16. Functional ground terminal

If excessive noise is produced when the speaker is connected to external equipment, connect this terminal to the external equipment's functional ground terminal, potentially minimizing the noise level.

Note

This terminal is not for protective ground.

17. Control input terminals

Allows input of control signals from connected external equipment to enable actions set in the Event settings.

18. DIP switch

• LINE/MIC switch (Switch 1)

Set this switch to MIC when connecting a microphone, and to LINE when connecting a general sound source device other than a microphone.

Default setting: LINE

• PAD switch (Switch 2)

Enables or disables the MIC input pad. When the input level is high, set the PAD to -20 dB.

Default setting: 0 dB

• PHANTOM switch (Switch 3)

Set whether or not to supply phantom power to the microphone connected to MIC IN. Phantom power is a 12 V DC.

Default setting: OFF

[Bottom]

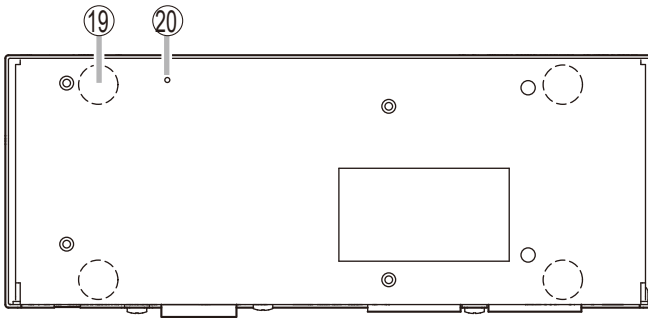

The figure with a removable terminal plug detached.

19. Rubber feet attachment position

20. Reset key

The unit begins to restart when this key is clicked.

Hold down this key until the Status indicator (1) lights yellow to initialize the unit's settings.

7. HANDLING PRECAUTIONS

- Please apply the latest firmware version to this product. The latest version is available at the TOA DATA Library (<https://www.toa-products.com/international/>).
- As this product is IP-based, a slight time lag between actual and broadcast may happen.
- Broadcast audio may sometimes break up due to packet loss or network failure.
- Periodic inspection and manual rebooting are needed to extend the product life.
- This product may reboot automatically to keep the stable operation.

8. UNIT MOUNTING

It is recommended to install it as shown in the example blow.

[Putting on the desk]

It can be used on a desktop by attaching the accessory rubber foot to the bottom of this unit.

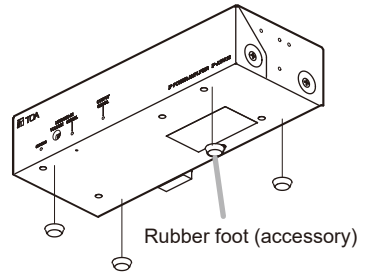

[Mounting on the wall]

It can be used mounting on the wall by the optional bracket MB-15B to the side of this unit. Use the 4 screw holes located on each side of the unit to fix it using the screws supplied with the optional bracket.

*1 Accessories of the MB-15B Bracket (option)

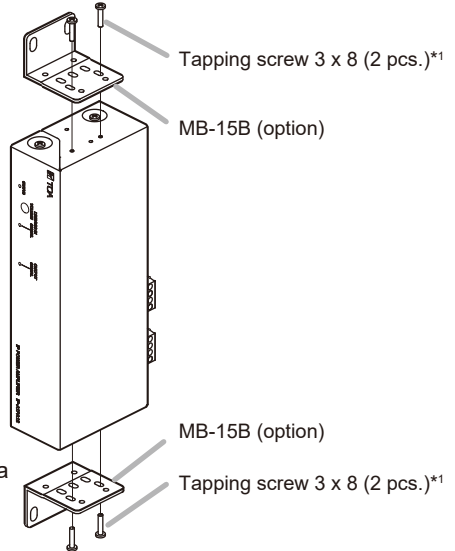

Note

Use metal fittings of sufficient strength and install in a place with sufficient strength.

[Rack Mounting]

It can be rack-mounted by using the optional bracket MB-15B-BK to the side of this unit.

Notes

- Use the screws supplied with the MB-15B-BK Bracket to attach the bracket to the unit.
- The MB-15B-J Joint Rack Mounting Brackets cannot be used to connect 2 units together.

*2 Component parts and accessories of the MB-15B-BK Bracket (option)

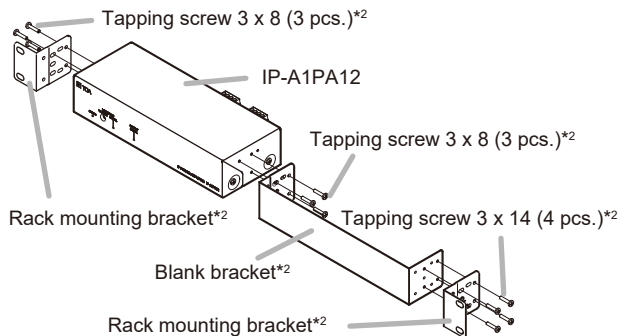

9. CONNECTIONS

9.1. Network Connection

Connect the IP-A1PA12 to the PoE+ switching hub using a LAN cable (straight UTP or STP cable, both rated at Category 5e or greater and fitted with RJ45 connectors).

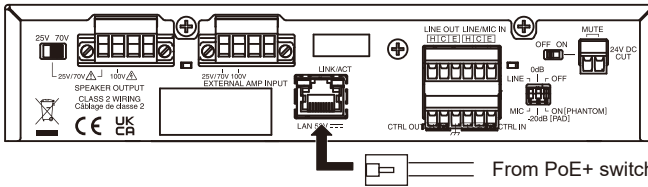

Compatible switching hubs:
Switching hubs conforming to PoE+ (IEEE802.3at Class 4) specifications

9.2. Connections to Speaker Output and External AMP Input Terminals

Use the supplied removable terminal plugs (4 pins) for connection. Use a speaker cable to connect the speakers or external amplifier. For connection of the removable terminal plugs, see "Removable Terminal Plug Connections" on p. 15.

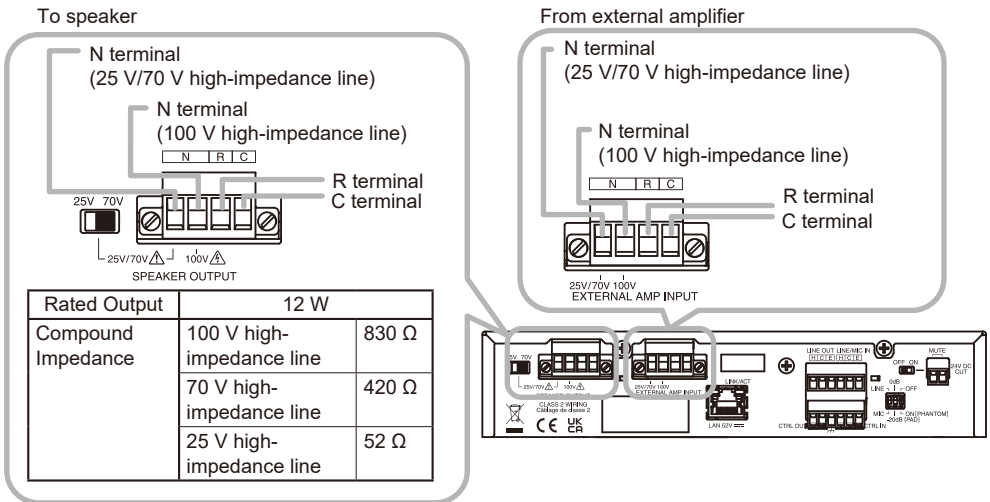

Note

Please take note of the following precautions when making connections in order to avoid failure of the unit or peripheral devices.

- The terminals marked with the symbol  are hazardous live. The external wiring to these terminals requires installation by an instructed person.
- Take care that power to the unit is switched OFF while performing speaker or external amplifier connections.
- Be sure to check speaker specifications to ensure correct connection to the proper terminals.
- Do not connect a speaker that exceeds the rated output.
- Avoid simultaneously using both the 100 V high-impedance line and the 25 V/70 V high-impedance line terminals.
- Ensure that the wiring distance to the furthest speaker from the IP Mini-Amp is under 500 m or 1640.42 ft (when $\varnothing 0.9 - 1.6$ mm cable is used).

9.2.1. Amplifier switching control

External amplifier inputs are enabled under the following control conditions:

- Power to the unit is turned OFF.
- The Mute setting switch is ON and the Mute terminal is receiving a 24 V DC cut-off signal.
- System mute in progress.
- Control input in progress (during event setting).
- Control is performed by external command.

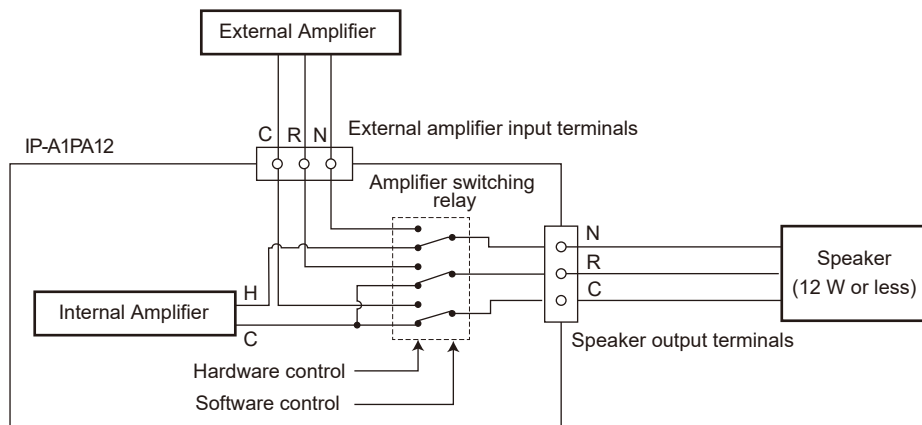

Tip

Hardware control refers to control via the power and Mute terminals. Software control signals are not accepted during hardware control.

9.2.2. Symbol

Symbol	Location	Description
	Rear panel	Caution Indicates a potentially hazardous situation which, if mishandled, could result in death or serious personal injury.
	Rear panel	Warning Indicates a potentially hazardous situation which, if mishandled, could result in death or serious personal injury.

9.3. Connections to LINE/MIC Input and Line Output Terminals

Use the supplied removable terminal plugs (6 pins) for connection. Use a 2-core shielded cable to connect the audio device.

For connection of the removable terminal plugs, see "Removable Terminal Plug Connections" on p. 15.

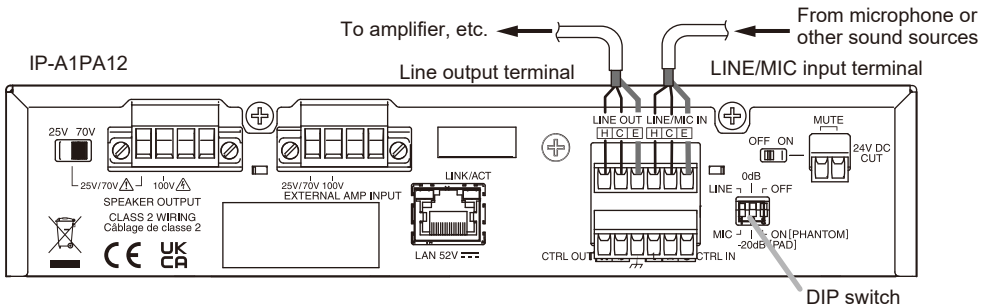
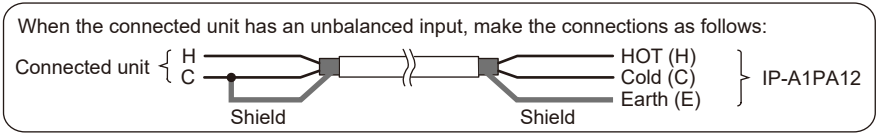

[DIP switch settings]

Set the DIP switch according to the audio device to be connected.

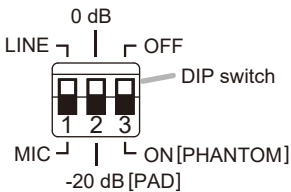

[Factory default setting]

Note

Please change DIP switch settings while the power is off.

Input device	DIP switch settings	
Line level sound source		1: LINE 2: 0 dB [PAD] 3: OFF [PHANTOM] (Default settings)
Dynamic microphone		1: MIC 2: 0 dB [PAD] 3: OFF [PHANTOM]
Electret condenser microphone		1: MIC 2: -20 dB [PAD] 3: ON [PHANTOM]
IP-A1MP microphone panel		1: LINE 2: 0 dB [PAD] 3: ON [PHANTOM]

[LINE/MIC input level adjustment]

Set roughly the volume of individual connected devices by DIP switch. After that, use the LINE/MIC input volume control for fine volume adjustments.

Adjust the level so that the LINE/MIC input signal indicator lights green, not red.

Note

Rotate the input volume control screw using an appropriate screwdriver. When rotating, do not press on the screwdriver with too much force, so as to avoid damage to the adjuster.

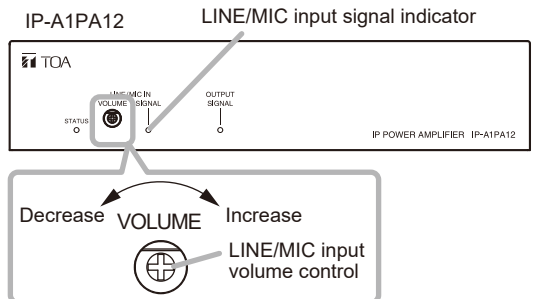

9.4. Connections to Control Input, Control Output, and Mute Terminals

Use the supplied removable terminal plugs (6 pins or 2 pins) for connection.

Connect a control line of 2 channels control input, 1 channel control output, and mute input from the external control device to the unit's control input or control output terminal.

For connection of the removable terminal plugs, see "Removable Terminal Plug Connections" on p. 15.

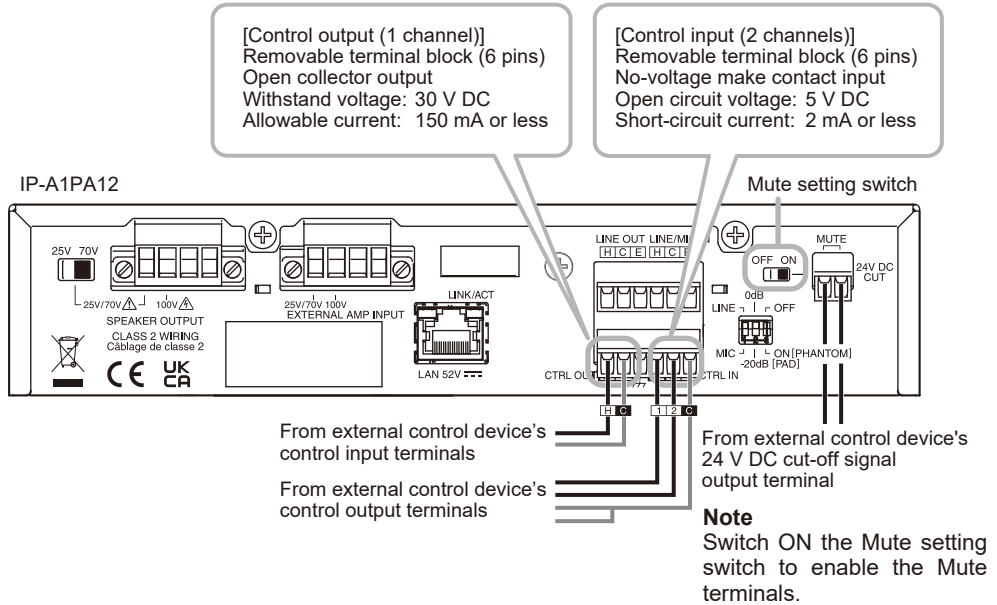

The following functions can be assigned to the control input and control output terminals by browser settings:

Terminals	Assignable Functions
Control input terminals	<ul style="list-style-type: none"> • SIP device calls • Internal sound source broadcasts • Local broadcasting • Change the speaker volume (Mute or volume offset) • Switch to external amplifier
Control output terminals	<ul style="list-style-type: none"> • SIP broadcast in progress output • VMS broadcast in progress output • Multicast broadcast in progress output • Internal sound source broadcast in progress output • Local broadcasting in progress output

For settings, please refer to the separate receiving device setup manual.

The latest version of the setup manual is available on the TOA DATA Library (<https://www.toa-products.com/international/>).

9.5. Removable Terminal Plug Connections

Please note the following points when making connections to the control input, control output, and speaker output terminals using the supplied removable terminal plugs:

- Do not tin stripped wire ends with solder.
Soldered wire ends will be crushed when the terminal plug screws are tightened, leading to higher contact resistance and potentially resulting in an abnormal rise in the temperature of the connected parts.
- Use AWG 24 – 14 wire ($\varnothing 0.5 - 1.6$ mm solid wire or multi-stranded wire with a cross-sectional area of $0.2 - 2.0$ mm²).
- Strip the wire end back about 7 mm (0.28").
- When connecting 2 wires or a signal cable to a single terminal, crimp them in an insulated (twin) wire ferrule to prevent their core wires from being separated from one another. Use a ferrule of the dimensions shown in the figure at right.

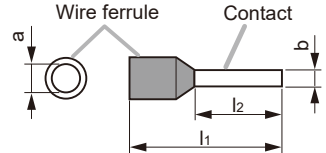

b: 0.8 – 1.1 mm (0.03" – 0.04")
l₂: 8 mm (0.31")

Note

Select dimensions "a" and "l₁" depending on the wires to be used.

[Plug Connection Procedure]

Step 1. Remove the plug from the terminal.

Step 2. Loosen the terminal screw and insert a wire.

Step 3. Tighten the screw firmly.

Note

Pull on the wire to ensure that it does not come off.

Step 4. Insert the plug into the terminal.

Tip

Recommended slotted screwdriver is as follows.
Blade width: about 2.5 mm (0.1")

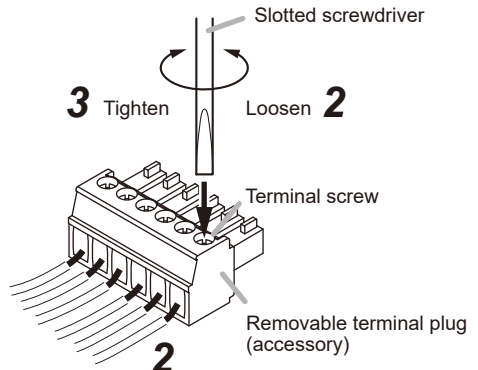
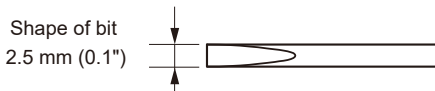

10. SETTINGS

10.1. System Settings Summary

The following settings can be performed using a PC browser connected to the same network as the IP audio interface.

Setting Name	Setting Item
Status	Confirmation of current firmware version, network settings, volume setting
Network	Network settings such as the IP address
SIP	Settings of SIP connection enable/disable, SIP server address, authentication information, and audio codec
VMS Broadcasting	Settings of VMS connection enable/disable and authentication information, connection port settings
Multicast	Settings of multicast reception enable/disable, multicast address and port, and control output during multicast broadcast
Local Broadcasting	Settings of local broadcasting function enable/disable and broadcasting mode (normal/no delay) Tip When the local broadcasting function is enabled, the audio (SIP call and VMS monitoring audio) from this unit to network is muted.
Audio	Settings of speaker volume, input volume for individual broadcast classifications, and the sensitivity of LINE/MIC input for SIP and VMS broadcasting
Media	Uploading/downloading or deletion of sound source files such as messages to or from the internal memory
Chime	Settings of chime output before and after broadcasts
Pattern	Registration of sound source playback to be associated with events as patterns
Event	Settings of operations to be synchronized with the control input and control output
Priority	Settings of priority order for each broadcast mode; SIP broadcast, VMS broadcast, multicast broadcast, internal sound source broadcast, and local broadcast
User	Changes to user name and password
Maintenance	Download and upload the configuration file, initialization, firmware update, hardware reboot, and downloading action logs
System	Date and time settings, NTP server settings, language setting, time zone settings, certificate settings

For more information, please refer to the separate receiving device setup manual.

The latest version of the setup manual is available on the TOA DATA Library (<https://www.toa-products.com/international/>).

10.2. System Requirements

Connectable system requirements are as follows:

Display	Resolution: 1920 × 1080 or greater
OS	Windows 10 Pro (64-bit), Windows 10 Home (64-bit), Windows 11 Pro, Windows 11 Home
Browser	Microsoft Edge, Google Chrome

Notes

- Windows and Microsoft Edge are registered trademarks of Microsoft Corporation of the United States in the United States and other countries.
- Google Chrome is a trademark of Google LLC of the United States in the United States and other countries.

10.3. Connection with Browser

10.3.1. Connection presets

The IP audio interface is factory-preset as follows:

Username: admin
Password: guest
IP address: 192.168.14.1
Subnet mask: 255.255.255.0
Default gateway: 0.0.0.0

Before connecting a PC to the IP Power Amplifier and changing its setting, it will be necessary to set the PC's network settings so that it can operate on the same network as the IP Power Amplifier. Take care that no IP addresses are duplicated in the same network.

For example, if the IP Power Amplifier's IP address is 192.168.14.1, set the PC's IP address to 192.168.14.10.

10.3.2. Making connection

Notes

- Avoid simultaneously connecting to the IP Power Amplifier from multiple PCs.
- Avoid simultaneously connecting to the IP Power Amplifier from a single PC using multiple browsers.

Step 1. Start the browser and enter the speaker's IP address in the address field.
The Login screen is displayed.

Step 2. Enter the username and password, and click the LOGIN button.
The Status screen is displayed, enabling a range of settings.

Note

For details regarding the setting method, please refer to the separate receiving device setup manual. The latest version of the setup manual is available on the TOA DATA Library (<https://www.toa-products.com/international/>).

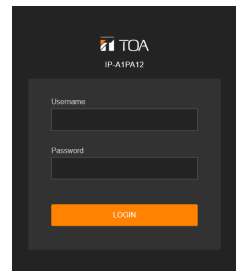

11. INITIALIZATION OF SETTINGS

Follow the procedure below to return all unit settings to their default:

Tip

When initialized with the reset key, the unit's sound source files and certificate files are left in "Media" and "System" respectively, not deleted. Initialization to factory defaults, including deletion of sound source files and certificate files, should be performed using the browser settings menu.

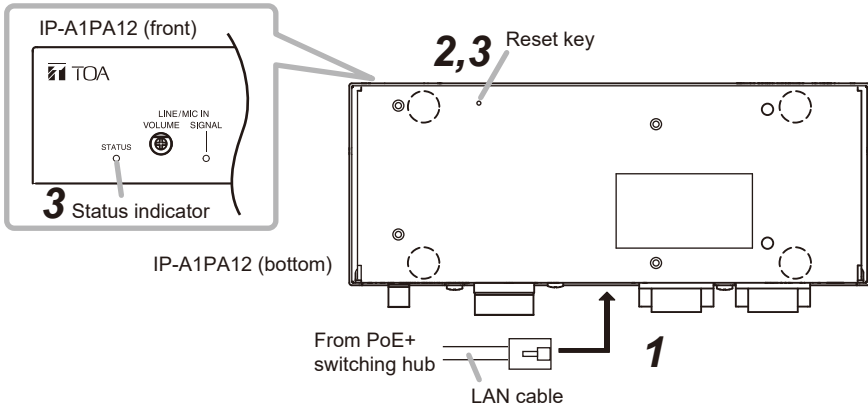

Step 1. Connect the speaker to the PoE+ switching hub using a LAN cable.
The unit will be started.

Step 2. Hold down the reset key located on the bottom panel using a pointed tool.
The unit automatically restarts and settings initialization begins.

Tip

Clicking on the reset key causes the unit to be restarted.

If pressure on the reset key is released part way through the initialization process, only unit restart will be performed, and the settings will not be initialized.

To click on the reset key, use a tool that is thinner than $\varnothing 1.5$ mm (0.06") and longer than 5 mm (0.2").

Step 3. When the status indicator lights yellow, release the reset key.
When initialization is complete, the status indicator lights green and all settings will be initialized to their default settings.

[Default Settings]

Username: admin
Password: guest
IP address: 192.168.14.1
Subnet mask: 255.255.255.0
Default gateway: 0.0.0.0

12. CAUTIONS REGARDING THE AVC/H.264 PATENT LICENSE

TOA's IP-A1PA12 IP Power Amplifier employs MPEG technology (AVC/H.264 Standard) regarding the handling of image information. TOA Corporation has received approval to use this technology from MPEG LA, LLC, the patent management group.

Please note that the use of this product is prohibited except the following cases:

The use of the product is intended for personal use of a user of the MPEG technology and also for non-profit use, which includes (i) video encoding conforming to the AVC/H.264 Standard (hereinafter referred to as "AVC/H.264") and/or (ii) personal use and decoding of AVC/H.264 encoded by an MPEG technology user engaged in non-profit activities and/or AVC/H.264 furnished by a video provider who is granted a license by MPEG LA, LLC.

Regarding use for sales promotion or commercial purposes, or additional licensing information, please contact MPEG LA, LLC (<https://www.mpegla.com>).

13. OPEN SOURCE SOFTWARE

This product uses software based on open source software license(s).

If you need further information about the original open source software including source code, please download it from the TOA DATA Library (<https://www.toa-products.com/international/>).

Please note that we cannot answer any questions about the contents of the original source code.

This product includes software developed by the OpenSSL Project for use in the OpenSSL Toolkit (<http://www.openssl.org/>).

This product includes cryptographic software written by Eric Young (eay@cryptsoft.com).

14. ACCESSORIES

Removable terminal plug (6 pins, preinstalled on the unit)	2
Removable terminal plug (2 pins, preinstalled on the unit)	1
Removable terminal plug (4 pins, preinstalled on the unit)	2
Rubber foot	4
Screw 3 x 6	4

Tip

The specifications of this product are available in TOA DATA Library (<https://www.toa-products.com/international/>).

Scan the QR Code at right with your mobile phone camera to access the WEB site and search for this product number (IP-A1PA12).



Traceability Information for USA

TOA Electronics, Inc.
1 Harmon Plaza, Suite 700 Secaucus, New Jersey 07094,
USA
<https://www.toaelectronics.com/>