

USER GUIDE



ANGRY AUDIO

PHONE

+1 (615) 763-3033

WEB

answers@angryaudio.com
www.angryaudio.com

ADDRESS

128 HOLIDAY CT STE 118
Franklin TN 37067 USA



Studio Signal Lights Studio Signal Light Gadget

Revision 2.0 - 07/23

Welcome to the world of Angry Audio, home of the audio Gadgets and Gizmos.

The audio world is filled with complex, high-tech gear. Much of it bristles with seductive shapes and eye-catching lights and displays, and all of it promises to make things sound better and open up new creative possibilities.

But in order for those products to shine, you still have to get the basics right and sweat the details. Good audio isn't made by one component. It's made by getting things right every step of the way, especially the little things.

A good studio is built by including components that make it a convenient and enjoyable place to create the content that dazzles your listeners, drives traffic to your advertisers, and allows you to pay some dude with a snowblower to clear your driveway when Ol' Man Winter comes around.

Accordingly, every Angry Audio product is designed to solve common yet critical problems, and is meticulously engineered with performance and longevity in mind to deliver pristine audio and reliable performance for many years.

Our promise and guarantee.

The Studio Signal Light and its companion, the creatively named Studio Signal Light Gadget, have become fan favorites and influence millions of YouTubers during their weekly late-night "Light It Up!" stream. We think you'll love them too. But we're also realists and understand you thought you'd love the Pajama Jeans, Flowbee, and TAC Glasses you ordered during your battle with insomnia. Things change. That's why we'll buy back your Gadget if you fall out of love within 30 days of purchase.

Every Angry Audio product is warranted to be free from defects in parts and workmanship for two full years after you purchase it. If it fails within this time period, Angry Audio, at its discretion, will repair or replace it so long as you let us know of the failure within the warranty period and can provide proof of purchase in the form of a dated sales receipt. You can call us at +1 615-763-3033, or reach us online at www.angryaudio.com/contact.

Making a good first impression.

When you unbox your Angry Audio product, we hope it makes a good first impression and you take a moment to appreciate the lengths we've gone to in order to create a "built for broadcast" product. All of our products are over-engineered to provide long-term reliability and guaranteed RFI immunity. Some of this is apparent, but much of this goodness is invisible, like the premium components within. Even if you can't see it, you'll hear it!

A word or two about safety.

There are certain things you just shouldn't do for safety's sake. Showering with your pet honey badger, for example, is not generally regarded as A Good Idea.

Unlike the honey badger, neither the Studio Signal Light nor its companion Gadget have any homicidal tendencies, so you can feel good about that. Neither do they have claws or teeth — also reassuring. However, our legal beagles insist that we insert the usual warning text here (and also that we take them on daily walks in the dog park).



Angry Audio Studio Signal Lights are intended to be installed and used by qualified personnel only. To avoid electric shock, do not open the unit or attempt to perform any servicing unless you are qualified to do so.

The Studio Signal Light operates on 12V, but receives that voltage from other devices like the Studio Signal Light Gadget, which has an internal 120VAC/240VAC power supply. Hazardous voltages are present whenever the unit is plugged in and may still be present on certain components even when unplugged.

Do not expose your Signal Lights, their power supply, or the Studio Signal Light Gadget to rain, moisture, or any other severe weather. Do not block any ventilation openings, as lack of airflow could damage the unit or create a fire hazard. Any electronic device can fail without warning; do not use this product in applications where a life threatening condition could result due to failure.

The power cord is the primary disconnect device and so the outlet providing power to the unit should be easily accessible. Use only a properly grounded outlet for power. Do not cut the ground pin or use a ground-lifting adapter, and do not defeat the polarized plug. Do not overload outlets.

Meet the Studio Signal Light!

Broadcasting is all about communication, right? But in addition to communicating to our listeners, we often have to talk with each other too. The producer needs to tell the DJ his interview is ready. The newsman needs to tell the producer there's something breaking. The G.M. has to tell the midday guy he's fired. How do you accomplish this when the mics are live? You can't just shout "Hey, Bozo!" and expect you won't receive a graphic hand gesture of the sort that would send your mother into a dead faint.

No, silent signaling is the thing you want to do, and the Angry Audio Studio Signal Light is the tool to help you do it.

There are 5 different models of Studio Signal Light, from 1 – 5 segments in size, all with bright, attention-getting LED rings to help you communicate. The Studio Signal Light works on any 12V source, which may be provided by your mixing console or any other power supply, and triggered via a manual switch, a relay, or an open collector output.

Several different "lit" states for your Signal Lights are possible: segments can provide a steady illumination, a commanding on-off flashing signal, or even a rotating "chase" effect — and all of these options may be set individually per segment.

Like all things Angry, setup is simple. Hookup to your power/control source is made using a common RJ45F connector.



Meet the Studio Signal Light Gadget!

So you've got this cool Signal Light. How do you power and control it?

A bright person like you could easily source your own power supply and breadboard some relays. Honestly, that sounds like a fun weekend project (if there weren't just shy of 10×4^3 other projects on your "to-do" list).

We've invented the Studio Signal Light Gadget to solve the problem. Just plug your Studio Signal Light into the Signal Light Gadget, flip a few front-panel switches, hook up your logic trigger connections, and you're free for other things. Controls on the front, connections on the back; as easy as making instant ramen, but with significantly less sodium.

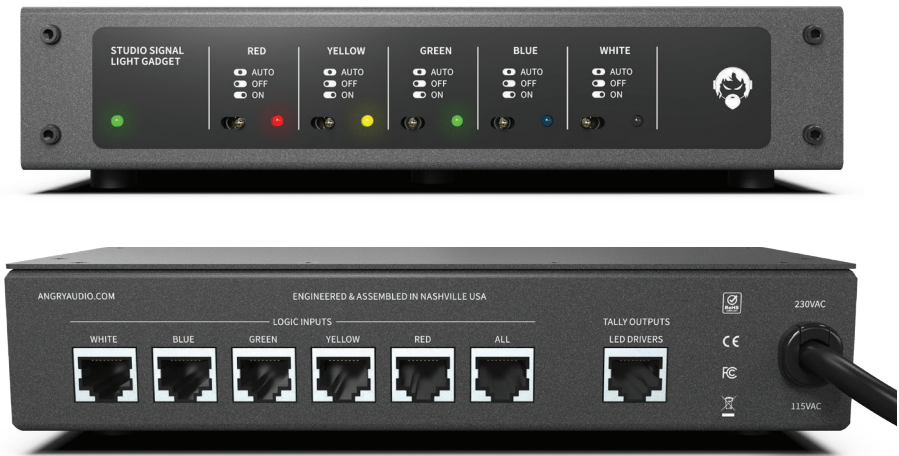

The Studio Signal Light Gadget has five LED drivers to light up to five different light segments. The front panel has LEDs that correspond to the segment colors; the adjacent switch lets you automatically trigger the lights via rear-panel GPI connections, or trigger each one manually if you like. The Gadget can control all five models of the Studio Signal Light; for smaller Signal Lights, just ignore the unused control sections.

On the back panel, every segment has a dedicated RJ45 for GPI. This makes it simple to use different devices to control different segments.

Additionally, the RJ45 marked "ALL" can control all five segments using one connection (useful when you want to control all of the lights with a single device). The drivers are all wired to a single RJ45 port, pinned to exactly match the RJ45 port on the Studio Signal Light. All you need is a CAT5 patch cable to connect the light and gadget.

Mounting your Studio Signal Light Gadget in a rack.

The Studio Signal Light Gadget sits on four rubber feet that ensure it won't scratch the Purple Heart inlays on your Herman Miller workstation.

If you prefer to rack mount your gadgets, you'll need the optional Rack Mount kit which allows one or two gadgets to be installed side by side in a standard 1RU rack space.

Each Rack Mount Kit consists of a custom rack panel with cut outs for all front panel controls and displays. A blank filler panel is also provided if you are mounting only one gadget.

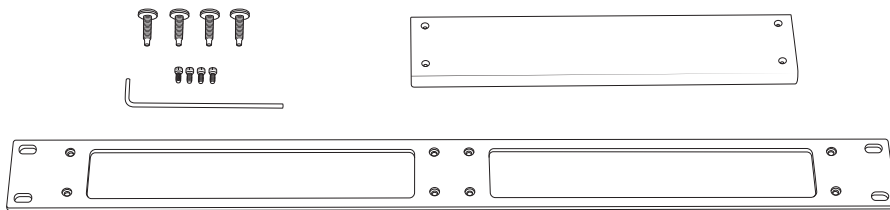

When rack mounting, remove the four rubber feet ("A") from the bottom of the gadget with a #1 Phillips screwdriver.

Remove the four front panel 3/32" hex screws ("B"). You can rummage around your toolbox for your own hex key, or use the one we thoughtfully provide in the mounting kit.

Line up the gadget so that the holes exposed after removing the socket head screws line up with the mounting holes ("C") in the rack panel.

Attach the rack panel to the front of your gadget with the same screws you just removed. If you dropped one and it immediately rolled to an inaccessible location (as these things always do), don't panic - we've included spares in the kit.

Finally, use the provided rack screws (all four, please) to mount your gadgets.

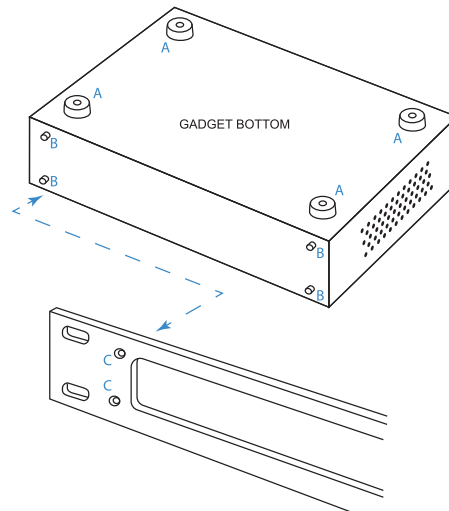

Attaching your Studio Signal Light Gadget to a wall.

If you prefer to secure your gadget to the inside of a rack, cabinet, or other flat surface, the optional Wall Mount kit comes in handy.

Each Wall Mount Kit includes two brackets, four No. 6 screws, and four cup washers.

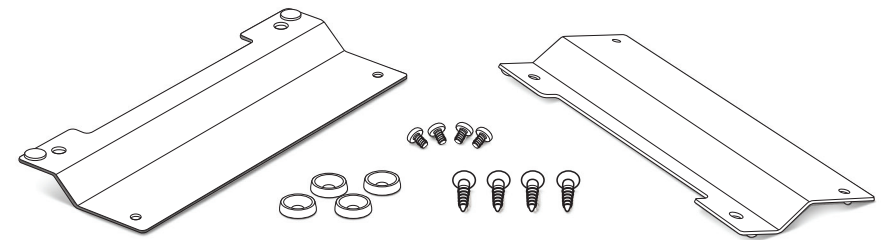

Remove the four rubber feet ("A") from the bottom of the gadget with a #1 Phillips screwdriver, being careful to save the screws.

Align the bracket holes with the holes in the bottom of the gadget, then attach the brackets using the screws removed from the rubber feet.

Use the four No. 6 screws ("B") and the four cup washers ("C") to secure the gadget to a plywood surface. Drilling pilot holes is recommended to reduce the risk of splitting the wood.

Different hardware (not supplied) will be required if you are mounting the gadget to a drywall (or other) surface.

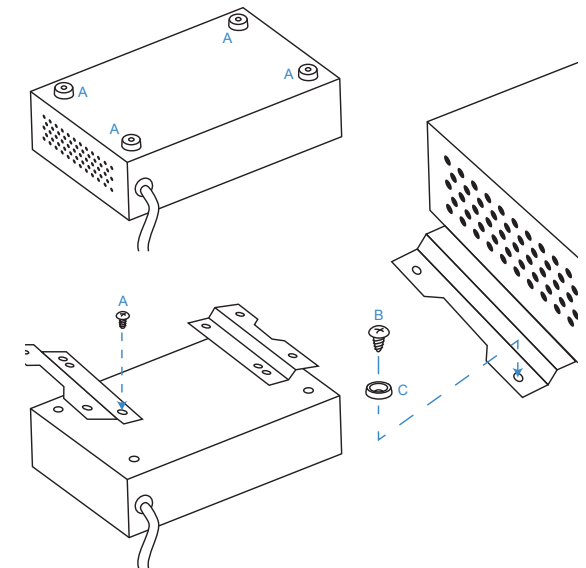

Mounting your Studio Signal Light Gadget under a counter.

Your Studio Signal Light Gadget can be mounted under a counter, desk, or table using the optional Under Counter Mount Kit.

This kit includes two brackets, four No. 6 wood screws, and four cup washers suitable for mounting to a plywood surface. Different hardware (not supplied) may be needed if the mounting surface is a different material.

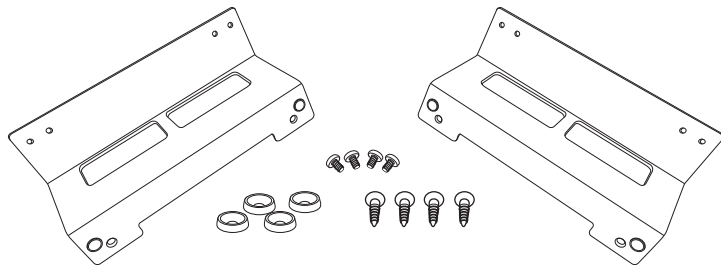

Remove the four rubber feet ("A") from the bottom of the unit using a #1 Phillips screwdriver, being careful to save the screws.

Line up the brackets ("C") so that their mounting holes line up with holes exposed after removing the rubber feet. Orient the brackets as shown in the diagram to the right so that the deeper flat side supports the gadget and the "notched" side faces the under-mount surface.

Use the pan-head screws ("B") removed from the rubber feet to secure the brackets to the gadget.

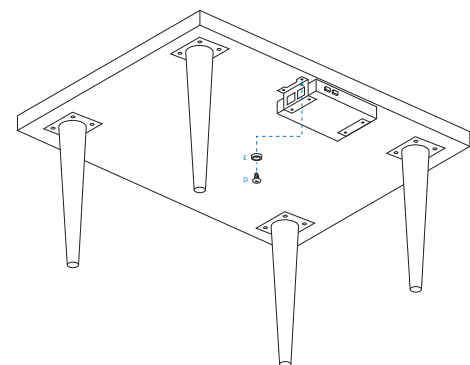
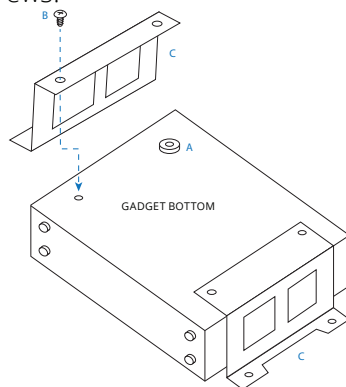

Use the four provided No. 6 screws ("D") and the four cup washers ("E") as shown in the diagram to the left to secure the gadget to the plywood underside of the counter, desk, or table.

Drilling pilot holes is recommended to reduce the risk of splitting the wood.

Using your Signal Light Gadget on a desktop.

If you like the idea of using the Studio Signal Light Gadget on a desktop but prefer a more permanent installation along with the convenience of having it angled up toward the user, we've got you covered with the optional Desktop Bracket Kit.

This kit includes two brackets, four No. 6 wood screws, and four cup washers suitable for mounting to a plywood surface. Different hardware (not supplied) may be needed if the mounting surface is a different material.

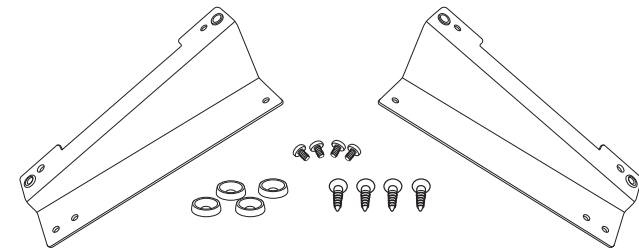

Remove the four rubber feet ("A") from the bottom of the unit using a #1 Phillips screwdriver, being careful to save the screws.

With the bottom of the Chameleon facing up and the front panel facing toward you, line up bracket "C" with the holes exposed after removing the feet on the right side of the gadget. Orient the bracket as shown in the diagram to the right so that the flat side is attached to the unit, and the "notched" side sticks up with the notch facing outwards. Use the pan-head screws ("B") removed from the rubber feet to secure the brackets to the unit.

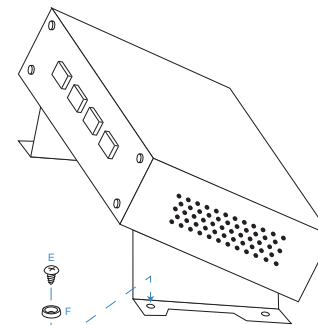
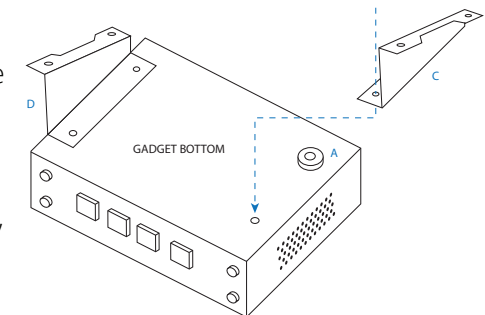

Use the four provided No. 6 screws ("E") and cup washers ("F") as shown in the diagram above to secure the gadget to a plywood surface.

Drilling pilot holes is recommended to reduce the risk of splitting the wood.

One handy-dandy printable template.

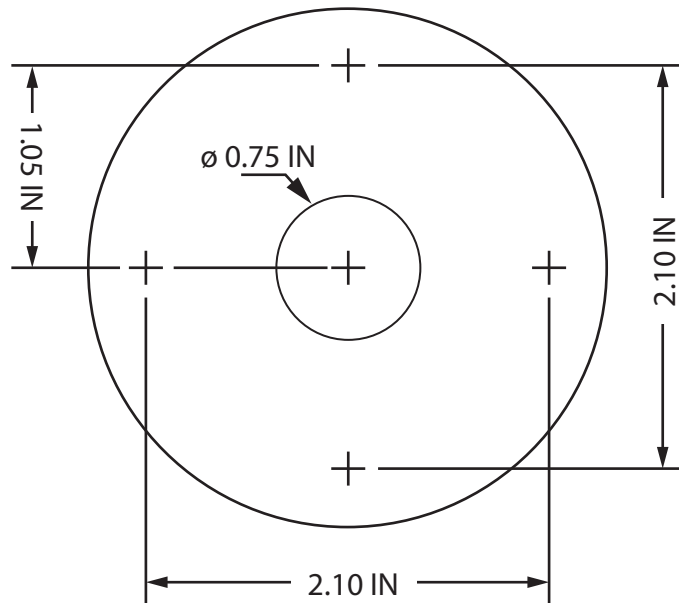

The Studio Signal Light is designed to be mount directly to studio furniture, on walls, cabinets, racks, or virtually any flat surface. (One exception: we don't advise mounting them to the floor. That's about as useful as a soup sandwich.)

- This template can be used as a guide for locating holes. Your printer must be set to print this page at 100% actual size. If your printer shrinks images to fit the page, the dimensions will be wrong. Measure the printed page with a ruler to make sure the printed dimensions match the actual size.
- Once you've decided where you want your Studio Signal Light, tape the template to the surface. Remember to place it where it is most visible, yet not in the way. Use an awl or center punch at all hole centers and remove the template.
- For hardwood, plywood or MDF desktops, drill a $\frac{1}{16}$ " (0.0625") pilot hole for each hole. Use the four wood screws to secure the Studio Signal Light. Do not over-tighten.
- For desktops constructed of other materials including stone or glass or those of a hollow (honeycomb) construction, the corner holes must be $\frac{1}{8}$ " (0.1375") diameter through holes to allow a bolt (not provided) to pass through the desktop and secured with a nut (also not provided) from beneath.

Using the Signal Light Gadget with our Signal Light.

The Studio Signal Light is pre-wired with an RJ45 connector, making it easy to connect to the Studio Signal Light Gadget. Simply plug a CAT5 cable of the appropriate length into the gadget's LED DRIVERS connector and plug the other end into the RJ45 on the Studio Signal Light.

- You can manually turn individual segments on and off using the front panel switch corresponding to each segment color. To control the segments using GPI logic, the switch must be in the center (AUTO) position. Manually switching OFF or ON will always override GPI logic.
- Each segment color has a dedicated RJ45 connector for its own GPI control. The connector is labeled by the corresponding color, i.e., red, yellow, etc. Activate the light by applying DC voltage from 5V to 24V across pins 1 and 2. Pin 1 is positive, pin 2 is negative. The input is optically isolated to prevent ground loop problems between devices.
- The Studio Signal Light's individual segments can be driven by different devices easily with the dedicated segment connectors. But if you have a device with multiple GPO signals that you'd like to use to drive multiple segments, you'll want to use the ALL connector. This presents GPI control for all five segments on a single connector.
- Perhaps you have an Axia system running Pathfinder and you want one GPIO port to drive all of the segments — easy! Just connect the Axia GPIO port +5VDC to ALL pin 8. Then connect the Axia GPO (lamp) pins to pins 1, 2, 3, 4 and 5. Activating each of the 5 GPOs will now control each of the five segments.

The diagram below shows the wiring connection between the Studio Signal Light and the Signal Light Gadget.

GADGET LED DRIVE RJ45		SIGNAL LIGHT RJ45	
PIN 01	RED (+)	PIN 01	RED (+)
PIN 02	YELLOW (+)	PIN 02	YELLOW (+)
PIN 03	GREEN (+)	PIN 03	GREEN (+)
PIN 04	BLUE (+)	PIN 04	BLUE (+)
PIN 05	WHITE (+)	PIN 05	WHITE (+)
PIN 06	NOT CONNECTED	PIN 06	NOT CONNECTED
PIN 07	+15VDC	PIN 07	NOT CONNECTED
PIN 08	COMMON	PIN 08	COMMON

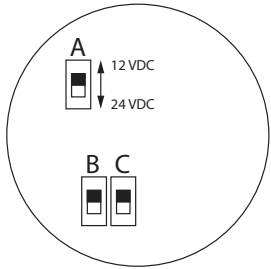

SWITCH	A	B	C
STEADY	UP	UP	UP
BLINKING	UP	DN	DN
ROTATING	UP	UP	DN

The Angry Audio Studio Signal Light is pre-configured for steady-state illumination. If you would prefer to have blinking effects, each segment has some internal switches that allow for several different modes.

Open the Signal Light by gripping the segment you wish to control in one hand and twisting the segment above it counter-clockwise. It will open easily and give you access to the switches (see diagram at left for switch settings). You can choose between steady-state (default) illumination, blinking and rotating. Reverse the above procedure to reassemble the Signal Light.

Please note there is a switch to select between 12V and 24V operation. When using our Signal Light Gadget, this should always be in the 12V (up) position.

Using the Signal Light Gadget to drive Yellowtec Litt signal lights.

Maybe you've got one of those gorgeous machined aluminum Yellowtek Litt tally lights. We have two things to say to you:

1. We're jealous!
2. Our Signal Light Gadget is the perfect way to power and control your Litt! Hooking up the inputs will be the same as described on the previous page.

Output connections, however, will be a little different. Litt requires an uninterrupted power supply source capable of enough current to light up all of the segments. We provide +15VDC @ 500mA on pin 7 of the LED Drive connector. Please see connection diagram below showing how to connect Litt to the Signal Light Gadget.

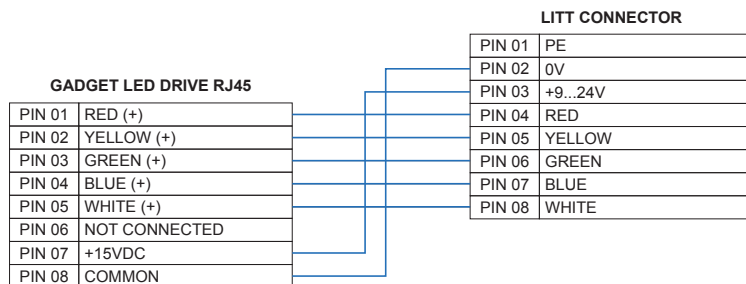

Using the Signal Light Gadget to drive other LEDs.

If you are driving the Angry Audio Signal Light, you select the blinking modes using the internal switches. If you are driving the Yellowtec Litt, the various blinking modes are set using a software programming tool. But what if you want to use the Signal Light Gadget to illuminate other LEDs? And what if you want those LED's to blink? No worries, we've got you covered.

Each segment color output is capable of delivering +12VDC @ 150mA, so make sure that's enough for your LED.

By default, the Studio Signal Light Gadget outputs are steady state, meaning when the switch is ON or the GPI active, the output is high. If you want your LED to blink, there is a jumper option inside the Gadget that can change the behavior of the output. Each segment has its own jumper that can be placed in one of three positions, steady, slow blink or fast blink. Use the diagram below to set the jumper positions for your desired effect

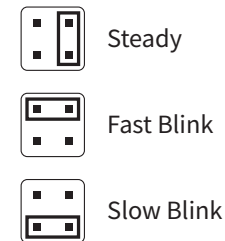

Just for fun.

Angry Audio takes great care to provide adequate warning for all equipment, but sometimes additional amplification is required. Please take special note of these common International symbols.



Studio Signal Light

Part Numbers & General Data

1-Segment: p/n# 991171
 2-Segment: p/n# 991172
 3-Segment: p/n# 991173
 4-Segment: p/n# 991174
 5-Segment: p/n# 991175

Light Technology: High Efficiency LED
 Light Display Functions: Steady, Flashing, Rotating
 Operating voltage: +12VDC or +24VDC
 Illumination Current: ≤ 75mA
 Interface Connector: RJ45

Shipping Weight & Dimensions

Shipping Dimensions: 10 x 4 x 4 inches (25.5 x 10.2 x 10.2 cm)
 Shipping Weight: 2 pounds (0.91 kg)

Studio Signal Light Gadget

Part Numbers

North America: p/n# 991045
 Australia: p/n# 991045A
 Europe: p/n# 991045E
 United Kingdom: p/n# 991045U

Connections

Logic (GPI) Input Voltage: +5VDC to +24VDC
 Drive Output Voltage: +12VDC, max 150mA per segment

Power and Environmental

Power Input: 115VAC 50/60Hz (North America Version)
 230VAC 50/60Hz (Australia, Europe, U.K. Versions)
 Power Consumption: 10VA
 Operating Temp.: 0° to 40° C (32° to 104° F)
 Storage Temp.: -20° to 45° C (-4° to 113° F)
 Relative Humidity: 0% to 90% non-condensing
 Cooling: Venting chassis (fanless)

Product Dimensions

Product Dimensions: 8.5 x 6.25 x 1.7 inches (21.6 x 16 x 4.32 cm)
 Product Weight: 3.5 pounds (1.59 kg)

Shipping Weight & Dimensions

Shipping Dimensions: 12 x 9 x 6 inches (30.5 x 22.9 x 15.3 cm)
 Shipping Weight: 5 pounds (2.27 kg)

