

Assembly Instructions

⚠ Important ⚠

Before you begin, read and comply with all safety and operating instructions, and ensure all parts and correct quantities are included.

Any parts damaged during shipment must be reported within 5 days of receipt. To report information regarding missing parts or damage, to purchase parts or accessories, or if you have any questions, please contact us.

www.spectrumfurniture.com
800-235-1262, 715-723-6750

Thank you for purchasing Spectrum products!

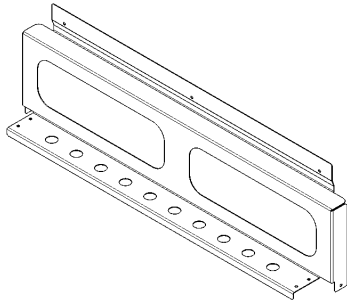

(3) 0205819
Adapter Bracket



(27) 0190174
#8 x 3/8" PHSM

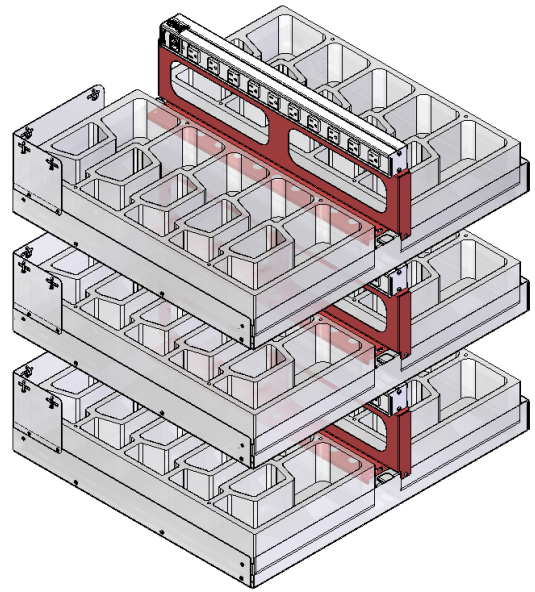

Adapter Bracket Kit Immersion XR Cart 2.0 55598



Assembly tip: Do not tighten component fasteners completely until all have been installed. Keeping them loose will help with alignment between parts during assembly.

1 Pull out drawer

1. Open the front doors and remove the locking rear panel.
2. Pull one drawer out fully.
3. Disconnect all power cords from the power strip and wall outlet.

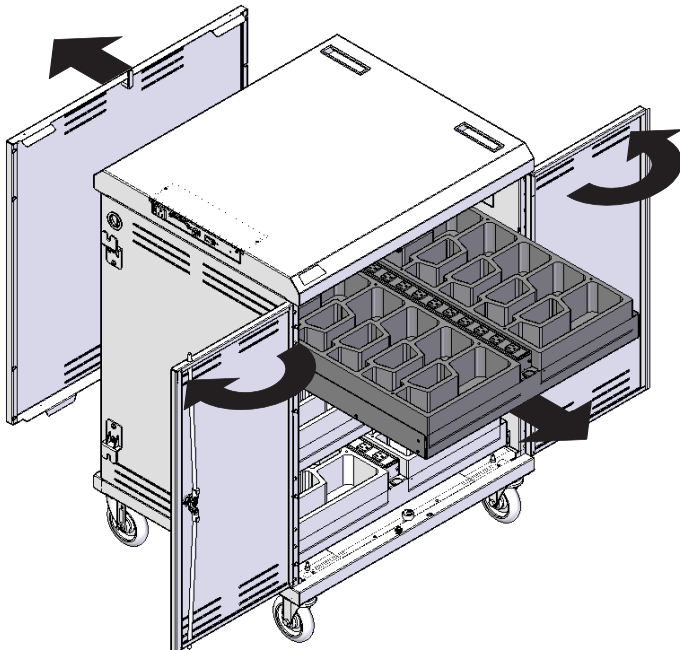

2 Remove power strip

1. Remove the (2) screws securing the power strip.
2. Push the power strip away from the front edge of the drawer to release it from the front drawer tab. (The drawer will need to flex slightly to release the tab.)
3. Unhook power strip from rear drawer tab and lift out.

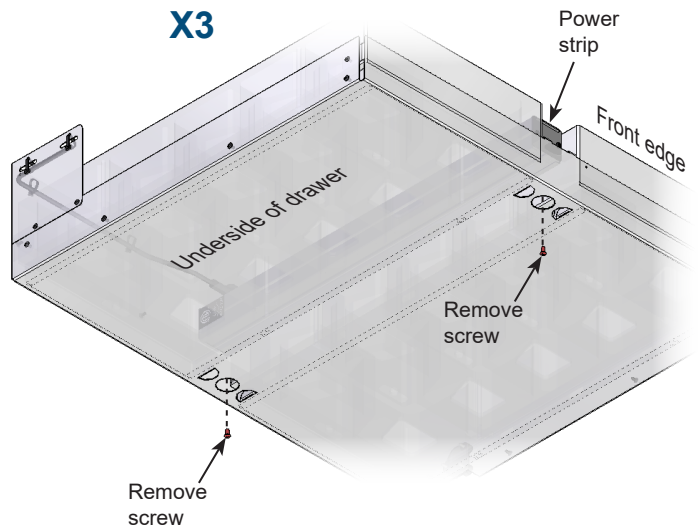

3 Install adapter bracket

1. Place adapter bracket into place as shown and align the mounting holes.
2. Attach the bracket to the drawer with (6) #8 x 3/8" PHSM screws.

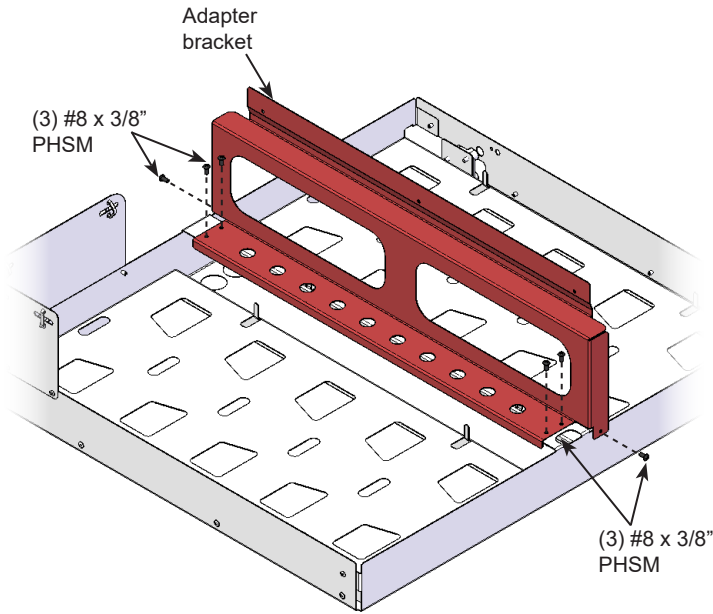

Note: Universal foam padding not shown for clarity

4 Attach power strip

1. Attach the previously removed power strip to the bracket with (3) #8 x 3/8" PHSM screws. Note the power strip is rotated 90° in the new position.
2. Plug in power cord.

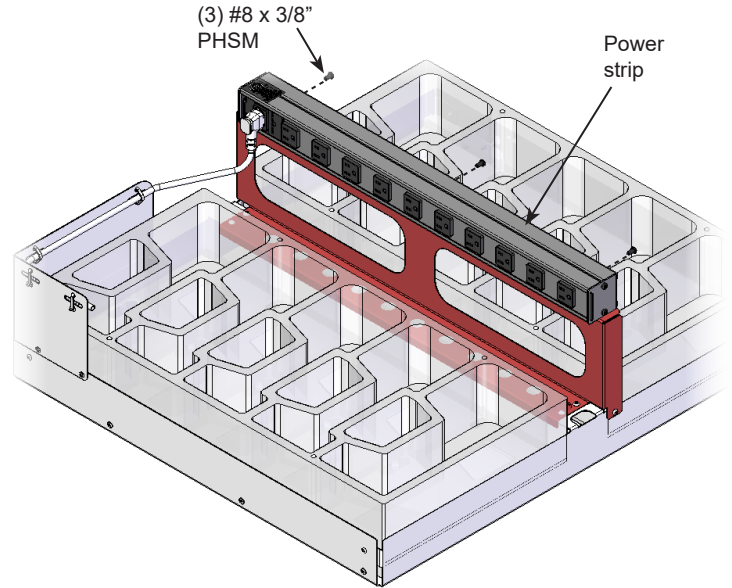

Note: Repeat above assembly steps on all 3 drawers to complete installation.