

EDIT

KONA

High-quality Tools for Post Production Professionals



Because it matters.

AJA[®]
VIDEO SYSTEMS

KONA

Solid performance and powerful features.
Unparalleled reliability. Built for video professionals
by video professionals.

KONA Connects.

KONA capture, display and mastering solutions for SD, HD, 3G, Dual Link HD, 2K and 4K on a Mac or PC, provide the engine for your post-production process.

The working professional—whether non-linear editor, compositor, motion graphics or 3D artist—needs to connect their software with a range of hardware.

KONA cards installed in your Mac or PC bring the world to you and your creativity to the world.

Ingest from Analog or Digital sources, such as Decks and Cameras.

Display your work in action on Broadcast Monitors, Plasmas and Projectors—all the way to 4K.

Monitor your multi-track audio through your Mixers and Speakers.

Master your project to HD and SD simultaneously on Digital or Analog tapes or disks.

It's in the hardware.

Master all formats with KONA.

In a world of myriad HD standards, SD, 2K and 4K, and growing 3D stereoscopic workflows, KONA cards offer maximum connectivity like 3G/HD/SD SDI, Component, and HDMI—along with the flexibility of superior conversion capability.

Unburden your CPU.

Within supported applications, KONA's Hardware Scalar Acceleration takes a portion of codec processing load off the CPU, allowing your computer to concentrate on what you care about, more Realtime effects.

No more rendering for raster resizing. KONA's superior "always-on" 10-bit hardware-based Up/Cross/Down conversion offers you the ability to ingest to the standard of your project while displaying and mastering live simultaneously to HD and SD as your needs require.

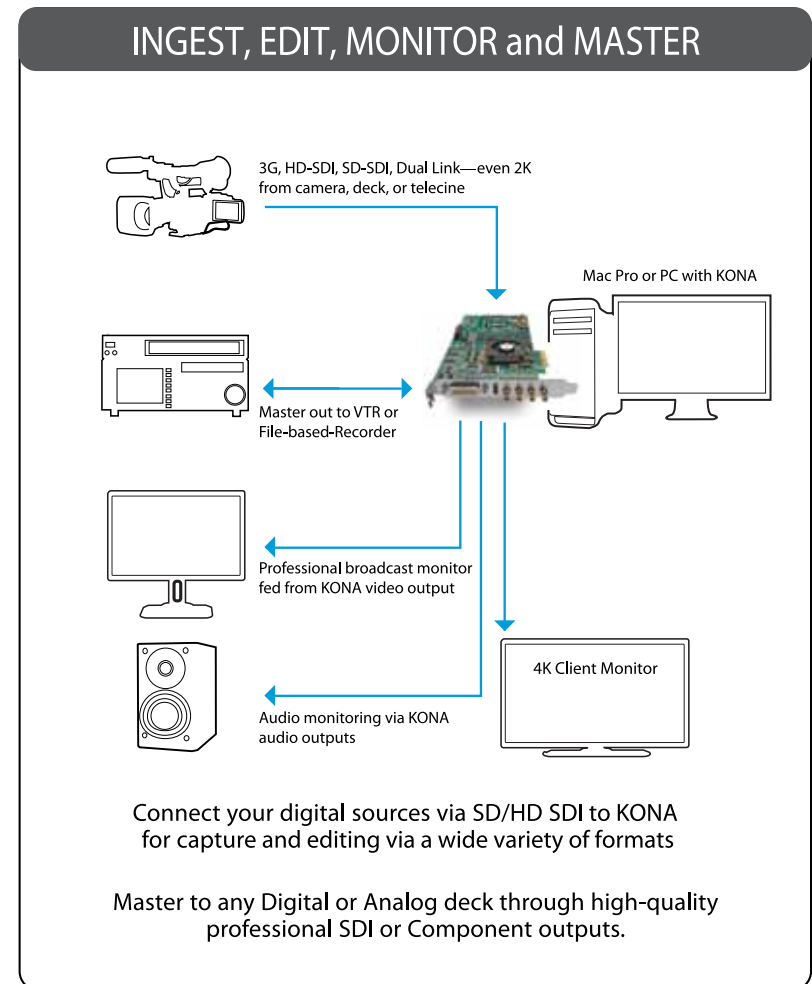

The KONA Family

KONA capture cards are available in three distinct models to meet your workflow needs. From the cost conscious KONA LHe Plus, affordable and flexible KONA LHi, to the top of the line KONA 3G with extended connectivity, AJA's reputation for Quality, Reliability and Support is evident in each.



KONA features	KONA 3G	KONA LHi	KONA LHe Plus
SD (NTSC and PAL)	yes	yes	yes
HD (720p, 1080i, 1080sf)	yes	yes	yes
2K (2048 x 1556, 2048 x 1080) Dual-Link HD, 2K HSDL, 4:4:4 RGB	yes	2K x 1080 video at 4:2:2, non-RGB	-
4K Playback (YCbCr and RGB colorspaces—rasters listed later under specifications)	yes	-	-
3G SDI	yes	yes	-
HDMI	HDMI 1.4a output	HDMI 1.3a input/output	-
HD to SD Down-conversion (10-bit, in hardware)	yes	yes	yes
SD to HD Up-conversion (10-bit, in hardware)	yes	yes	-
HD to HD Cross-conversion (1080 to/from 720, 10-bit, in hardware)	yes	yes	-
12-bit Analog Video (component, composite, and Y/C)	output SD/HD	input/output SD/HD	input/output SD/HD
10-bit SDI Digital Video (BNC)	input/output SD/HD/3G	input/output SD/HD/3G	input/output SD/HD
HD Video+Key	yes	-	-
Analog Audio (balanced XLR)	-	input/output 2-channel	input/output 2-channel
AES Digital Audio	8-ch I/O w/cable, 16-ch I/O w/K3G-Box	input/output 2-channel	input/output 2-channel
Embedded SDI Audio (via BNC)	input/output 16-channel	input/output 8-channel	input/output 8-channel
Professional Genlock	yes	yes	yes
LTC Input/Output	yes	LTC input (shared with reference BNC)	-
RS-422 Machine Control	yes	yes	yes
1RU Breakout Box (optional)	yes	yes	yes
3-year AJA Warranty with Advanced Exchange	yes, included	yes, included	yes, included
Capture DPX, Cineon, and DVCPRO HD	Mac/PC	Mac/PC	Mac/PC
Capture TGA, TIF, BMP, YUV, AVI (PC only) and QuickTime	Mac/PC	Mac/PC	Mac/PC
DVCPRO HD hardware scaling acceleration	Mac/PC	Mac/PC	Mac/PC
HDV hardware scaling acceleration	Mac/PC	Mac/PC	Mac/PC
Dynamic RTExtreme hardware scaling acceleration	Mac	Mac	Mac

KONA for Mac Software



AJA KONA for Mac drivers are optimized for use on OS X, with applications and advanced AJA hardware capabilities controlled easily at-a-glance in the application you're using. KONA for Mac software integrates within the native environment where used—whether Apple Final Cut Pro, Adobe Creative Suite, Autodesk Smoke for Mac, or a wide array of other Mac applications.

Within Apple Final Cut Pro X, KONA offers:

- The new Final Cut Pro X is supported by KONA models with AJA KONA X Beta drivers. Stay tuned to www.aja.com for evolving support for this important new platform.



Within Apple Final Cut Pro 7, KONA offers:

- Easy Setups for instant configuration of your workflow in unison with KONA hardware.
- Advanced hardware configuration from the AJA Control Panel can be accessed without leaving your application by simply holding down the command key and clicking into the UI.
- HDV codec hardware acceleration. The KONA hardware allows instantaneous realtime playback for both monitoring and recording.
- DVCPRO HD codec hardware acceleration. KONA's precision scaling hardware is used during capture and playback of video to and from the DVCPRO HD codec, freeing up valuable RT processing power.
- Dynamic RT Extreme video scaling support. Dynamic RT Extreme video scaling is offloaded in realtime to KONA as the "Playback Video Quality" dynamically adjusts.

Within Adobe Creative Suite

- Advanced AJA Plug-ins support offering control of KONA using familiar controls and appearance within Adobe CS applications including Adobe Premiere Pro, Photoshop, and After Effects.
- Photoshop broadcast video output to broadcast monitors.
- Realtime RAM preview monitoring from within After Effects.
- Save software rendering time with hardware-based KONA Up/Cross/Down Conversion.
- Native capture support for file per frame formats such as DPX, Cineon, TIFF, TGA and BMP.



Within Autodesk Smoke® for Mac

Autodesk® Smoke® for Mac OS® X software supports the AJA KONA 3G for capture, display, and output, from SD to 2K in stereoscopic 3D or mono projects.



All Mac Applications benefit

The KONA Desktop feature allows broadcast design elements to be viewed with the proper aspect ratio and color depth on a broadcast monitor via the KONA card. KONA Desktop is available on the entire range of KONA cards, supporting Adobe After Effects, Photoshop, Apple Motion, Autodesk Smoke for Mac and more.

Powerful AJA utilities, Easy Setups, and plug-ins round out the Mac environment providing support for all popular Mac application workflows.



KONA for PC Software

KONA for PC software allows Windows to access the hardware power of your KONA within major editing and graphics applications. Other software vendors have also provided integrated support for KONA in their own PC applications through direct collaboration with AJA.

Choose the right KONA card to playback HD/SD or SD-only video and audio data from disk—even 2K—in any format you choose, including DPX, Cineon, TGA, TIFF, BMP, AVI and QuickTime. You can playback and master material, at a variety of frame rates, on a high-resolution wide-screen monitor or digital projector. Custom AJA software allows full control over your playback parameters are clearly laid out, including provisions for choosing a user-specified LUT.

Supplied AJA plug-ins integrate your KONA card into a variety of graphics/visual-effects software applications to make operations even easier to use. Using AJA plug-ins, sophisticated features appear as if they were native to the software application user interfaces. Directly supported applications include:

- Adobe Premiere® Pro
- Adobe After Effects®
- Adobe Photoshop®
- Sony Vegas
- Eyeon Fusion®



This huge feature set makes KONA an invaluable tool for film and video professionals, for virtually any PC workflow.

AJA Control Room for Mac and PC

KONA software for Mac and PC includes a stand-alone powerful capture, conversion, playback, and output application—AJA Control Room™—that includes full VTR machine control with access to any and all KONA supported file formats and video standards, presented in a very cool and easy-to-use interface. Files captured from AJA Control Room can be imported into virtually any software package that supports these file formats, such as compositing programs, 3D animation programs, audio editing programs and much more. Exported files from your applications can be seamlessly played out to the video and audio equipment of your choice. A separate Control Panel supplies powerful at-a-glance configuration and control.

AJA Control Room has great desktop preview features allowing you to preview your files full screen on your desktop display, creating an alternative for frame by frame viewing when no additional monitor is available. When you're ready and you want to lay off to tape, an Output mode allows you to edit to tape using a wide variety of VTRs.



AJA Control Room™ for Capture, Preview, and Output to Tape (Mac and PC)

It's in the software

AJA uniquely offers not only the driver software support, optimized platform compatibility and plug-ins you expect for leading editing and graphics applications like Apple Final Cut Pro on the Mac or Adobe Creative Suite on a Mac or PC, but also a range of additional standalone software applications that extend your power and capability.

AJA Control Room for Mac and Windows



All KONA cards ship with AJA Control Room™, an all-inclusive application for configuration, video/audio ingest, conversion, as well as capture, playback and mastering to tape—all within a single easy-to-use application. Users can configure their video/audio I/O via a separate Control Panel which can be launched from AJA Control Room.

Capture to a wide variety of audio and video formats using the Capture mode of the AJA Control Room application. The straightforward UI makes capturing video from traditional VTRs—or from a live camera feed—easy.

A Playback mode lets users output their files from the wide variety of AJA audio/video connectivity found on KONA products. Connect to monitors and projects and use the simple playback tools for screenings and evaluations.

Finally, an Output mode allows users to perform an edit to tape using a wide variety of VTRs.



AJA DataCalc (DataRate Calculator)

Calculate your storage needs before digitizing even begins and keep your team on track.



AJA System Test

Tune your system to the same high standards that developers do for the best performance.



AJA QTToDPXTranslator and AJA DPXToQTTTranslator

Take a 2K or HD 10-bit RGB QuickTime movie captured with your KONA 3G and translate it to file-per-frame DPX or accomplish the opposite. Work in realtime with DPX source files within Final Cut Studio. Only AJA makes it possible.

It's the Compatibility

Visual artists have a range of software applications and platforms they prefer and need to work with. No other manufacturer can match the breadth of application support and needs of the working professional. Pick your application of choice and KONA connects it to your world.

Software Compatibility	KONA 3G	KONA LHi	KONA LHe Plus
Apple Final Cut Pro 7*	Mac	Mac	Mac
Apple Color	Mac	Mac	Mac
Apple Motion	Mac	Mac	Mac
Apple Soundtrack	Mac	Mac	Mac
Apple Logic	Mac	Mac	Mac
Adobe Premiere Pro	Mac/PC	Mac/PC	Mac/PC
Adobe After Effects	Mac/PC	Mac/PC	Mac/PC
Adobe Photoshop	Mac/PC	Mac/PC	Mac/PC
MacCaption/Caption Maker	Mac/PC	Mac/PC	Mac/PC
AJA TV	Mac	Mac	Mac
AJA VTR Xchange	Mac	Mac	Mac
AJA Machina	PC	PC	PC
AJA Data Rate Calculator	Mac/PC	Mac/PC	Mac/PC
AJA System Test	Mac/PC	Mac/PC	Mac/PC
Autodesk Smoke On Mac	Mac	—	—
Autodesk Combustion	PC	PC	PC
Drastic Media NXS	PC	PC	PC
Sony Vegas	PC	PC	PC
Eyeon Fusion 64 bit	PC	PC	PC
CineForm Neo HD	Mac/PC	Mac/PC	Mac/PC
CineForm Neo 3D	Mac/PC	Mac/PC	—
CineForm Neo 4K	Mac/PC	Mac/PC	—
The Foundry Nuke	Mac/PC	Mac/PC	Mac/PC
Media 100	Mac	Mac	Mac
Softron	Mac	Mac	Mac
Gallery	Mac	Mac	Mac
Building4Media	Mac	Mac	Mac
Bug.tv	Mac	Mac	Mac
ToolsOnAir	Mac	Mac	Mac

* At the time of publishing, Final Cut Pro X is supported by KONA beta drivers

Cross-Platform Power

When looking for a cross-platform hardware solution, KONA is an excellent fit. KONA can be used interchangeably in either Mac OSX or Windows; with the new AJA Control Room software, KONA will even run on Linux. KONA allows users the freedom to use applications on different platforms, or collaborate with users on opposite platforms and pass assets between each other without having to render each time. KONA supports QuickTime ingest and playback on both OSX and Windows, allowing seamless and elegant file interchange between operating systems.

KONA^{3G}

Power. Performance. Price.
Multi-format Digital I/O



KONA 3G has the unparalleled features top of the line video professionals expect from AJA Desktop solutions.

KONA 3G features 10-bit Uncompressed video I/O, 4K playout, the newest HDMI 1.4a support for 3D workflows, 16-channel SDI embedded audio I/O, and up to 16-channel AES digital audio I/O (8 with breakout cable or 16 with optional K3G-Box). Add to that realtime hardware-based up/down/cross conversion for efficiently working with a wide variety of SD and HD, 3G, dual-link HD, even 2K formats, a hardware downstream keyer for compositing graphics without rendering, and so much more.

3D Stereoscopic flexibility

KONA 3G offers you the most affordable and simplest path through 3D Stereoscopic workflows. Through SDI, you can output Discrete Left and Right Eye feeds with a simple Stereo button choice in the AJA Control Panel. In addition, all the muxed feeds for SDI stereo monitoring are accessible through tight integration with CineForm's stereo codecs in Apple FCP and Adobe Premiere Pro timelines for Side by Side and Top Bottom.

Through HDMI 1.4a, you can utilize more affordable 3D monitors for Side by Side and Top Bottom needs.

Broadcast-quality conversions

KONA 3G features full 10-bit, broadcast-quality, motion-adaptive SD to HD up-conversion, HD to HD cross-conversion, HD to SD down-conversion, and automatic HD/SD 12-bit component analog output. Since all conversion functionality on the KONA 3G is hardware-based, it's available all the time on ingest or playback.

Uniquely, the KONA 3G can cross-convert 720p 23.98 to 1080PsF 23.98. Cross-conversion is particularly valuable in today's multi-format HD post environment where producing pristine 720p or 1080i signals at-will helps streamline dailies and deliverables.

Internal SD/HD hardware downstream keyer

The AJA KONA 3G features a powerful hardware downstream keyer that can place graphic files with an alpha channel over the video being input to the board—or a selectable color matte, or the contents of the card's framebuffer (ex: AJA TV/Apple Final Cut Pro). The downstream keyer can also key a QuickTime video clip that has an alpha channel by playing it in realtime, via the supplied AJA TV application, over live video coming into the card.

Connectivity

For SDI video, the card features two 3G/HD/SD-SDI inputs and two outputs—or for 4K playout all four SDI connectors can be used for output, HDMI 1.4a monitoring output, LTC input and output, one connection for Genlock input, and configurable 3x BNC HD/SD analog video output.

Also included is a 9-pin connector for RS-422 machine control. If you're using a Digital Betacam, DVCPRO50, HDCAM, DVCPRO HD, D5, or HDCAM SR VTR—or any other professional device—you'll have the proper connections.

Dual link HD support

KONA 3G supports Dual Link 4:4:4 HD-SDI, with full bandwidth 4:4:4 RGB at 10-bits for 1080i, 1080p, 1080PsF and 720p formats. KONA 3G can also convert between 4:4:4 and 4:2:2 formats for single link HD-SDI monitoring and output.

2K support

As the most capable 2K card for the Mac, you can use KONA 3G to ingest from 3G or HSDL (high speed data link) equipped sources and record at full frame rate or record simultaneous 2K DPX files and 2K QuickTime reference movies using the AJA VTR Xchange application. You can also work with existing 2K material, like sequential DPX or Cineon files, by using AJA's DPXToQT Translator application to create QuickTime files for a wide variety of applications. RED Epic and ARRI Alexa workflows are eased by KONA 3G, with true realtime 2K playback and LUT support.

On a PC, KONA 3G can connect to a 2K telecine saving time and steps by directly creating 2K DPX, QuickTime, Cineon, AVI, TGA, TIFF or BMP files. Users can capture directly into the format they need and move files immediately into their editing/compositing environment of choice. These same files can be played out at 2K via 3G or High Speed Data Link (HSDL), offering further synergy with other 2K products already in use in the market.

KONA 3G also allows 2K files to be viewed with a user selected crop function on HD 1080PsF supported video monitors. This functionality helps lower the price barrier for viewing 2K material.

4K playout

Leading the way for quality 4K monitoring, KONA 3G offers 4K playback in both YCbCr and RGB. When 4K playout is selected, the four SDI connectors are remapped as outputs for driving four quadrants of a 4K display. A large number of 4K formats are supported for this emerging workflow.

KONA^{3G}

Audio

Tie the KONA 3G to a digital audio mixer or DAW output with 8-channel 24-bit 48kHz or 96kHz AES audio via BNC connections on the supplied breakout cable—or get the optional K3G-Box to output an even larger 16-channels of AES audio.

KONA 3G's high-quality input sample-rate conversion on AES inputs eliminates the need for audio source synchronization.

For multi-channel audio mastering, 16-channel SDI embedded 24-bit 48kHz audio provides the power you need to integrate into any audio environment.

Extend your Connectivity with K3G-Box for KONA 3G

The optional K3G-Box simplifies connectivity in professional post-production environments by offering a 19-inch, 1RU rack-mountable breakout box that attaches to the KONA 3G via an included multi-pin cable and two cables supplied with the KONA 3G. Additional K3G-Box functionality over the standard breakout cable comes in the form of 8 additional AES audio channels, 2-channel RCA analog audio monitoring jacks, and looping BNC Genlock reference connectors.



KONA 3G breakout cables (supplied)

KONA 3G breakout cable (supplied)

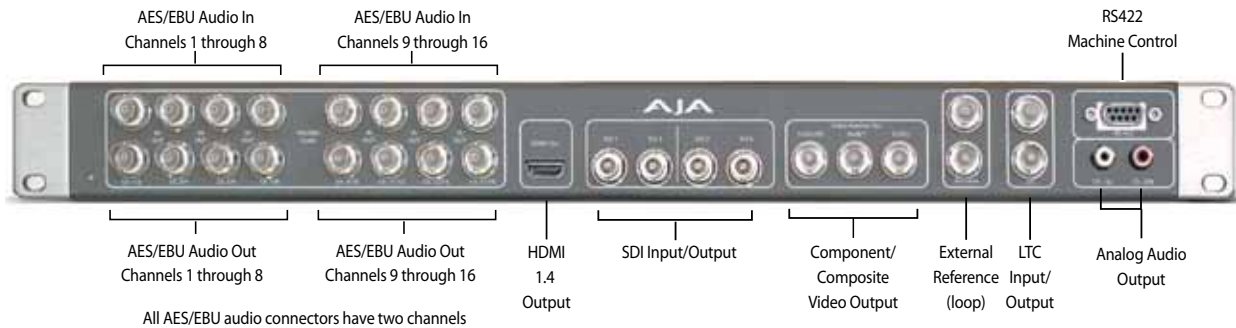
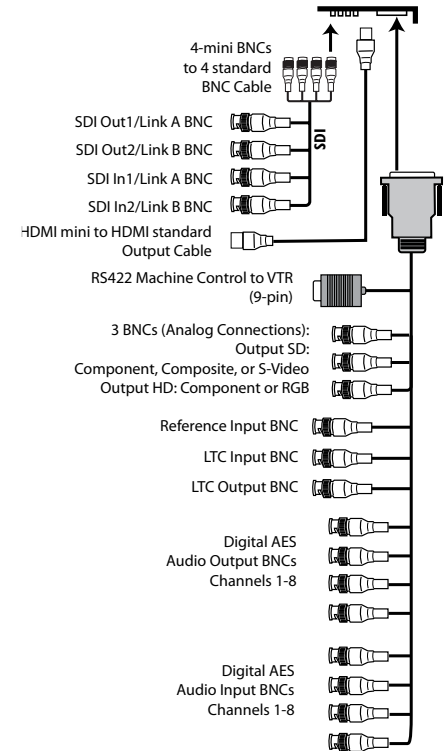

K3G-Box for KONA 3G (Optional)

KONA^{LHi}

The Most Flexible Card for Analog and Digital Standard and High Definition Workflows



The AJA KONA LHi bridges the gap between legacy analog devices and the latest 3G SDI and HDMI enabled products providing editing, monitoring and mastering of professional quality video in an affordable, powerful, easy to use product.

Connectivity

If your post-production facility works with a wide variety of formats, frame rates and audio/video sources, the AJA KONA LHi provides the connectivity you need.

Connect everything from an HDMI enabled camera to an HD-SDI VTR to KONA LHi. Connecting to any of your legacy analog video signals is also possible through configurable component, composite, or s-video. Via an Input PassThrough mode, you can even configure the card to act as a converter within your computer.

KONA LHi offers a full host of no-compromise features: 10-bit or 8-bit uncompressed video, 2-channel AES digital audio and 8-channel SDI embedded digital audio, analog composite or s-video or SD/HD component video I/O, 2-channel balanced analog audio I/O, and broadcast-quality hardware-based up/down/cross-conversion for flexible SD and HD post production.

KONA LHi's HDMI 1.3a support allows you to feed a "deep color" monitor with quality 10-bit video, banishing video banding and preserving your gradients and rich color palate.

Broadcast-quality conversions

Like the AJA KONA 3G, the KONA LHi features full 10-bit, broadcast-quality, motion-adaptive SD to HD up-conversion, HD to HD crossconversion, HD to SD down-conversion, and automatic HD/SD 12-bit component analog output. Since KONA LHi's conversions are hardware-based, they are available all the time - during ingest or playback. Outputs can be configured independently allowing you to have simultaneous HD and SD output—or two different types of HD: 720 or 1080—output at the same time via cross-conversion.

Extend your Connectivity with KLHi-Box

The optional KLHi-Box provides all the standard features of a cable for 1RU rack mounted I/O convenience and added connectivity in the form of additional BNC digital AES/EBU connectors and RCA audio monitoring jacks.

KONA LHi breakout cable (supplied)

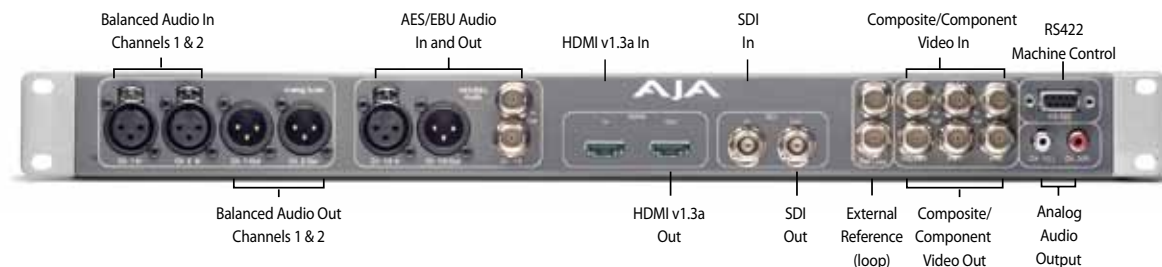
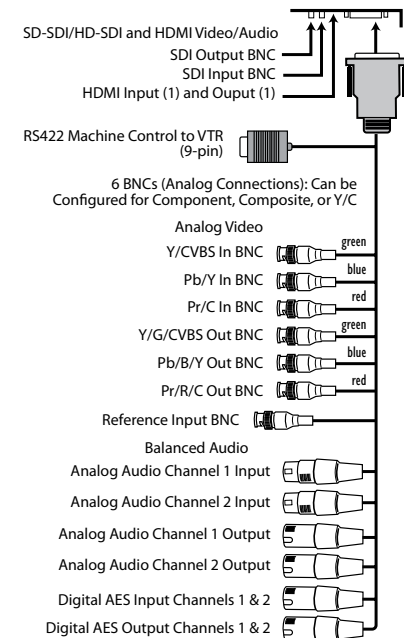

KLHi-BOX for KONA LHi (Optional)

KONA LHe Plus

Analog and Digital capture card for SD and HD with a Downconverter



KONA LHe Plus offers a full host of professional no-compromise features: 10-bit or 8-bit uncompressed video, 2-channel AES digital audio and 8-channel SDI embedded digital audio, analog composite or s-video or SD/HD component video I/O, 2-channel balanced analog audio I/O, and broadcast quality hardware down-conversion from HD to SD.

For SDI video, the KONA LHe Plus features one input and two outputs and can be configured independently for HD or SD. It offers Genlock input, and three BNCs which may be configured for analog video input and output (HD or SD). Also included is a 9-pin connector for RS-422 machine control. Because the KONA LHe Plus supports analog component HD input and output, devices with analog HD output, such as HDV decks and even game consoles, can be connected for a variety of workflows.

KONA LHe Plus features full 10-bit, broadcast-quality, motion-adaptive HD to SD down-conversion, and HD/SD 12-bit component analog output. Since conversion is hardware-based, it's available all the time - during ingest or playback.

Extend your Connectivity with KL-BOX-LH

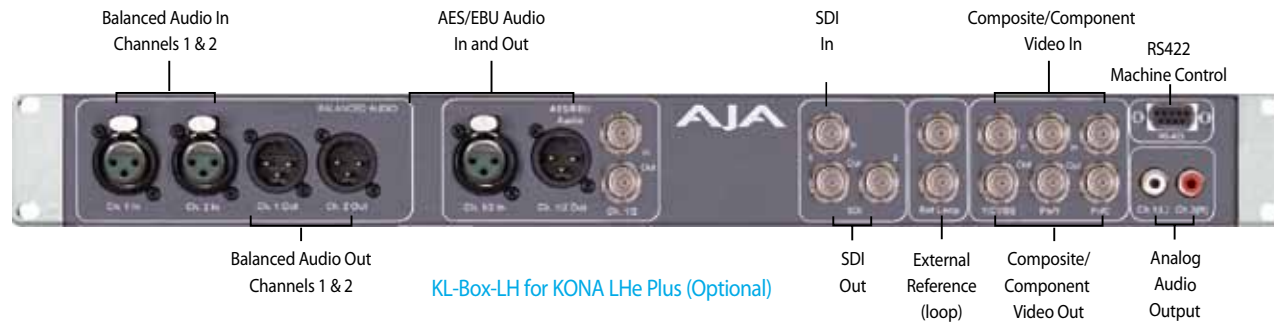

KL-Box-LH for KONA LHe Plus (Optional)

KONA LHe Plus breakout cable (supplied)

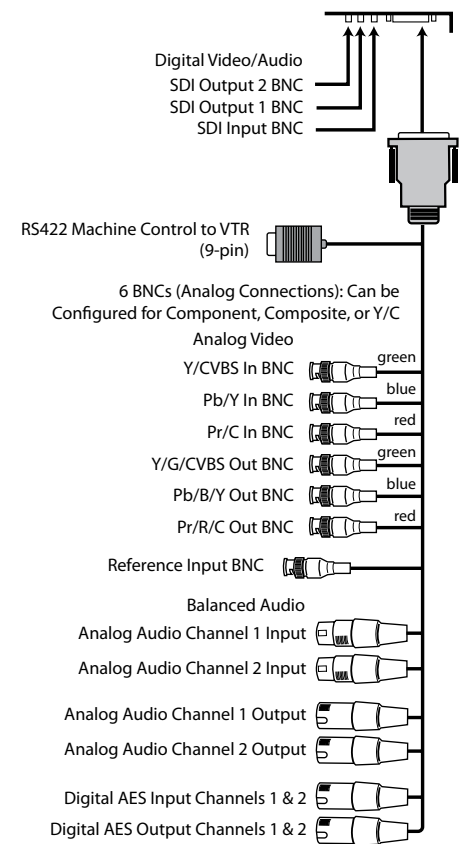

Specifications

KONA 3G Specifications

Video Inputs

Dual-rate (SD or HD)
 3G SD and HD-SDI, SMPTE-259/292/296/424, 10-bits
 Single Link 4:2:2
 Dual-link HD 4:4:4
 2K HSDL (High Speed Data Link) 4:4:4
 1D LUT Support (Mac and PC)

Video Formats

480i 29.97
 525i 23.98 (intermediate format only)
 525i 29.97
 625i 25
 720P 23.98 (intermediate format only)*

720p 24 *

720p 25 *

720p 29.97*

720p 30 *

720P 50

720P 59.94

720P 60

1080i 25

1080i 29.97

1080i 30

1080PsF 23.98

1080PsF 24

1080PsF 25

1080PsF 29.97

1080PsF 30

1080p 23.98

1080P 24

1080P 25

1080P 29.97

1080P 30

1080P 50

1080P 59.94

1080P 60

2048 x 1080P 23.98

2048 x 1080P 24

2048 x 1080PsF 23.98

2048 x 1080PsF 24

2048 x 1556p 15

2048 x 1556PsF 14.98

2048 x 1556PsF 15

2048 x 1556psf 23.98

2048 x 1556PsF 24

Video Output

Digital:

3G SD and HD-SDI, SMPTE-259/292/296/424
 Dual-link HD 4:4:4 and 2K HSDL 4:4:4
 4K playback via 4 SDI, YCbCr and RGB
 HDMI v1.4, 30/36 bits/pixel, RGB or YUV, 2.25Gbps

Analog:

SD and HD Output, 12-bits, BNC

HD: YPbPr, RGB

SD: YPbPr, RGB (component mode) or Composite +

Y/C (composite mode with simultaneous Y/C)

4K Playout

Video Formats

3840x2160P 24

3840x2160P 23.98

3840x2160P 25

4096x2160P 24

4096x2160P 23.98

4096x2160P 25

3840x2160PsF 24

3840x2160PsF 23.98

4096x2160PsF 25

4096x2160PsF 24

4096x2160PsF 23.98

4096x2160PsF 25

Downstream Keyer:

Will output graphics with alpha channel over video, matte or framebuffer, or framebuffer content over incoming video or matte

Audio

24-bit SDI embedded audio,

16 channel, 48kHz

24-bit AES audio, 8 channel w/breakout cable or 16

channel with optional K3G-Box, 96kHz or 48kHz

24- or 16-bit capable

Up-Conversion

Hardware 10-bit

Anamorphic: full-screen

Pillar box 4:3: results in a 4:3 image in center of screen

with black sidebars

Zoom 14:9: results in a 4:3 image zoomed slightly to fill a

14:9 image with black side bars

Zoom Letterbox: results in image zoomed to fill full

screen

Zoom Wide: results in a combination of zoom and

horizontal stretch to fill a 16:9 screen; this setting can

introduce a small aspect ratio change

Down-Conversion

Hardware 10-bit

Anamorphic: full-screen

Letterbox: image is reduced with black top and bottom

added to image area with the aspect ratio preserved

Crop: image is cropped to fit new screen size

Cross-Conversion

Hardware 10-bit

1080i to 720P

720P to 1080i

720P to 1080PsF

SD to SD Aspect Ratio Conversion

Letterbox: This transforms SD anamorphic material to a

letterboxed image.

H Crop: Will produce a horizontally stretched effect on the

image; transforms anamorphic SD to full frame

SD Pillarbox: Will produce an image in the center of the

screen with black borders on the left and right sides

and an anamorphized image in the center

V Crop: Will transform SD letterbox material to an

anamorphic image.

Reference Input

Analog Color Black (1V) or Composite Sync (2 or 4V)

Non terminating, Looping, 75 ohm on K3G-Box,

terminated on supplied breakout cable

LTC

Input and Output, 2 BNCs

Machine Control

RS-422, Sony 9-pin protocol

KONA LHi Specifications

Video Input

Digital:
 3G SD and HD-SDI, SMPTE-259/292/296/424, 10-bits
 HDMI v1.3

Analog:

Composite/S-Video (Y/C):
 NTSC, NTSCJ, PAL 12-bit A/D, 2x oversampling

3 line adaptive comb filter decoding

SD Component:

SMPTE/EBU N10, Betacam 525 line,

Betacam 525J, RGB

12-bit A/D, 2x oversampling

HD Component:

YPbPr

12-bit A/D

1D LUT Support (PC)

Video Formats

525i 29.97

625i 25

720p 23.98 *

720p 24 *

720p 25 *

720p 29.97 *

720p 30 *

720p 50

720p 59.94

720p 60

1080i 25

1080i 29.97

1080i 30

1080PsF 23.98

1080PsF 24

1080PsF 25

1080PsF 29.97

1080PsF 30

1080P 23.98

1080P 24

1080P 25

1080P 29.97

1080P 30

1080P 50

1080P 59.94

1080P 60

Video Output

Digital:

3G SD and HD-SDI, SMPTE-259/292/296/424

HDMI v1.3, 30/36 bits/pixel, RGB or YUV, 2.25Gbps, SD,

HD, 1080p50/60

Analog:

Composite/S-Video (Y/C):

NTSC, NTSCJ, PAL

12-bit D/A, 8x oversampling

SD Component:

SMPTE/EBU N10, Betacam 525 line,

Betacam 525J, RGB

12-bit D/A, 8x oversampling

HD Component:

YPbPr, RGB

12-bit D/A, 2x oversampling

Audio

Digital:

24-bit SDI embedded audio,

8 channel, 48kHz

24-bit AES audio, 2 channel, 48kHz

16-bit capable

Analog:

24-bit A/D and D/A, 2 channel balanced

XLR, 48kHz

+24dbu Full Scale Digital

+/- 0.2db 20 to 20kHz frequency response

Up-Conversion

Hardware 10-bit

Anamorphic: full-screen

Pillar box 4:3: results in a 4:3 image in

center of screen with black sidebars

Zoom 14:9: results in a 4:3 image zoomed slightly to fill a

14:9 image with black side bars

Zoom Letterbox: results in image zoomed to fill full

screen

Zoom Wide: results in a combination of zoom and

horizontal stretch to fill a 16:9 screen; this setting can

introduce a small aspect ratio change

Down-Conversion

Hardware 10-bit

Anamorphic: full-screen

Letterbox: image is reduced with black top and bottom

added to image area with the aspect ratio preserved

Crop: image is cropped to fit new screen size

Cross-Conversion

Hardware 10-bit

1080i to 720P

720P to 1080i

720P to 1080PsF

SD to SD Aspect Ratio Conversion

Letterbox: This transforms SD anamorphic material to a

letterboxed image.

H Crop: Will produce a horizontally stretched effect on the

image; transforms anamorphic SD to full frame

SD Pillarbox: Will produce an image in the center of the

screen with black borders on the left and right sides

and an anamorphized image in the center

V Crop: Will transform SD letterbox material to an

anamorphic image.

Reference Input

Analog Color Black (1V) or Composite Sync (2 or 4V) Non

terminating, Looping, 75 ohm on KLHi-Box, terminated

on supplied breakout cable, BNC assignable as LTC input

or Reference Input

Machine Control

RS-422, Sony 9-pin protocol

KONA LHe Plus Specifications

Video Input

Digital:
 SD and HD-SDI, SMPTE-259/292/296, 10-bits

Analog:

Composite/S-Video (Y/C):
 NTSC, NTSCJ, PAL

12-bit A/D, 2x oversampling

3 line adaptive comb filter decoding

SD Component:

SMPTE/EBU N10, Betacam 525 line,

Betacam 525J, RGB

12-bit A/D, 2x oversampling

HD Component:

YPbPr

12-bit A/D

Video Formats

525i 29.97

625i 25

720p 23.98 *

720p 24 *

720p 25 *

720p 29.97 *

720p 30 *720p 50

720p 59.94

720p 60

1080i 25

1080i 29.97

1080i 30

1080PsF 23.98

1080PsF 24

1080p 24

1080p 25

1080p 29.97

1080p 30

Video Output

Digital:

SD-SDI, SMPTE, 259M, 10-bits, BNC

HD-SDI SMPTE, 292/296, 10-bits, BNC

Analog:

Incredible 3 Year Warranty

AJA Video warrants that KONA products will be free from defects in materials and workmanship for a period of three years from the date of purchase.

About AJA Video Systems, Inc.

Since 1993, AJA Video has been a leading manufacturer of video interface and conversion solutions, bringing high-quality, cost-effective digital video products to the professional broadcast and post-production markets. AJA offers the Io and KONA desktop video products, Ki Pro family of recorders, miniature stand-alone converters, and a complete line of rack mount interface and conversion cards and frames. With a headquarters and design center located in Grass Valley, California, AJA Video offers its products through an extensive sales channel of dealers and systems integrators around the world. For further information, please see our website at www.aja.com

B e c a u s e i t m a t t e r s .



AJA Video Systems Inc.
Grass Valley, California

www.aja.com • sales@aja.com • support@aja.com