

Digital 4K Video Camera Recorder

PXW-Z100

Operating Guide

Before operating the unit, please read this manual thoroughly and retain it for future reference.

XDCM[™] **XQD**[™] **XAVC**

4K **HDMI**[™] **InfoLITHIUM**[™] **L**
HIGH-DEFINITION MULTIMEDIA INTERFACE SERIES

Table of Contents

Overview

Location and Function of Parts	5
On-Screen Indications	12
LCD/viewfinder screen	12

Preparations

Power Supply	14
Charging the battery pack	14
Setting the Clock	16
Attaching Devices	16
Attaching the supplied microphone	16
Attaching the lens hood with lens cover	17
Adjusting the LCD screen and viewfinder	17
Using XQD Memory Cards	18
About XQD memory cards	18
Inserting an XQD memory card	18
Removing an XQD memory card	18
Selecting the memory card slot to be used for recording	19
Formatting an XQD memory card	19
Checking the remaining time available for recording	19
Using a USB Wireless LAN Module	20
Attaching the IFU-WLM3	20
Making a Wi-Fi connection	20
Using the Wi-Fi remote commander	21
Using a UTILITY SD card	24
Usable SD Cards	24
Inserting an SD Card	24
Removing an SD memory card	24
Formatting an SD Memory Card	24
Checking the Remaining Time	24

Recording

Basic Operation Procedure	25
Changing Basic Settings	28
Recording format	28
Adjusting the image brightness	28
Adjusting to natural color (White balance)	29
Audio setup	31
Time data	32
Useful Functions	33
Assignable buttons	33
Slow & Quick Motion	33

Thumbnail Screens

Thumbnail Screens	35
Configuration of the screen	35
Playing Clips	36
Playing the selected and subsequent clips in sequence	36
Clip Operations	36
Operations of the thumbnail menu	36
Displaying the detailed information of a clip	37
Deleting clips	38
Changing information on the thumbnail screen	38

Settings

Setup Menu Operations	39
Setup Menu List	40
Camera menu	40
Paint menu	41
Audio menu	43
Video menu	44
LCD/VF menu	44
TC/UB menu	47
Recording menu	47
Media menu	48
File menu	48
System menu	49
Thumbnail menu	51

External Devices Connection

Connecting External Monitors and Recording Devices	52
Operating Clips with a Computer	53
Connecting with a USB cable	53

Appendices

Important Notes on Operation	54
Recording time of movies	54
Using your camcorder abroad	56
Formats and Limitations of Outputs	61
Video formats and output signals	61
Error/Warning Indications	64
Error indications	64
Warning indications	64
Licenses	66
On accessing software to which the GPL/LGPL applies	66
Open software licenses	66
Specifications	66
Package configuration	68
Index	70

Overview

Location and Function of Parts

For functions and usage, see the pages in parentheses.

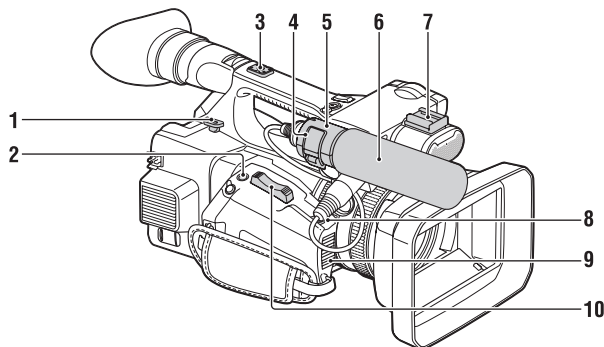

- 1. Hook for shoulder strap (8)
- 2. ASSIGN 7/FOCUS MAGNIFIER button (33)
- 3. Accessory shoe mount
- 4. Microphone fixing clamber (16)
- 5. Microphone holder (16)
- 6. Microphone (16)

- 7. Accessory shoe
- 8. IRIS PUSH AUTO button
- 9. Air inlet

Notes

- Areas around the exhaust vents may become hot.
- Do not cover the exhaust vents.

- 10. Power zoom lever (25)

To mount the accessory shoe

Mount the accessory shoe on the accessory shoe mount as illustrated.

Accessory shoe plate

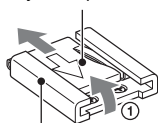

Accessory shoe

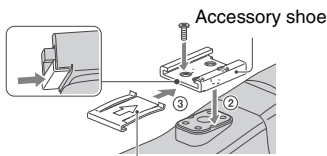

Accessory shoe plate

1. Lift the edge of the accessory shoe plate and pull it in the direction opposite to that of the arrow on the accessory shoe plate and remove it from the accessory shoe.
2. Place the accessory shoe as its protrusions matches recesses of the accessory shoe mount, then fix it to the mount with four screws.
3. Insert the accessory shoe plate in the direction of the arrow on the plate surface until the end of the plate engages the end of the shoe.

To remove the accessory shoe

Remove the shoe plate in the same way as step 1 of “To mount the accessory shoe.” Loosen the 4 screws and remove the accessory shoe from the accessory shoe mount.

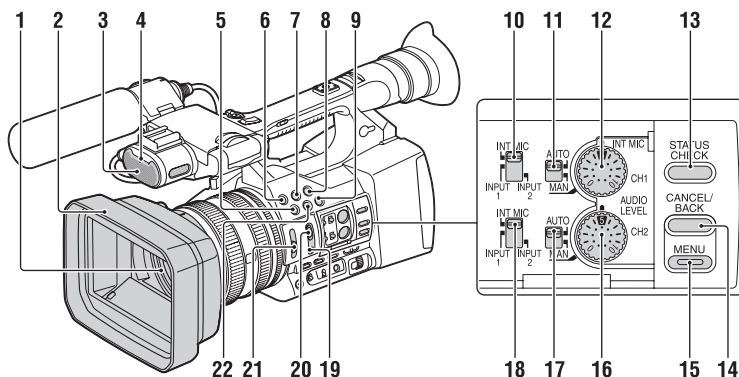

1. Lens (17)
2. Lens hood with lens cover (17)
3. Internal microphone (31)
4. Front recording lamp (49)
The recording lamp flashes if the remaining capacity of recording media or battery is low.
5. ASSIGN 4/ZEBRA button
6. ASSIGN 1 button
7. ASSIGN 2 button*
8. ASSIGN 3 button
9. ASSIGN 6/THUMBNAIL button
10. CH1 (INT MIC/INPUT1/INPUT2) switch
11. AUTO/MAN (CH1) switch (32)
12. AUDIO LEVEL(CH1) dial (32)
13. STATUS CHECK button (9)
14. CANCEL/BACK button (39)
15. MENU button** (39)
16. AUDIO LEVEL(CH2) dial (32)
17. AUTO/MAN (CH2) switch (32)
18. CH2 (INT MIC/INPUT1/INPUT2) switch (32)
19. PUSH AUTO button (26)
20. FOCUS switch (26)
21. ND FILTER switch (29)
22. ASSIGN 5/PEAKING button*

* The ASSIGN 5/PEAKING button and the ASSIGN 2 button have raised tactile dots for your convenience in locating the button.

** MENU button has a raised tactile bar for your convenience in locating the button.

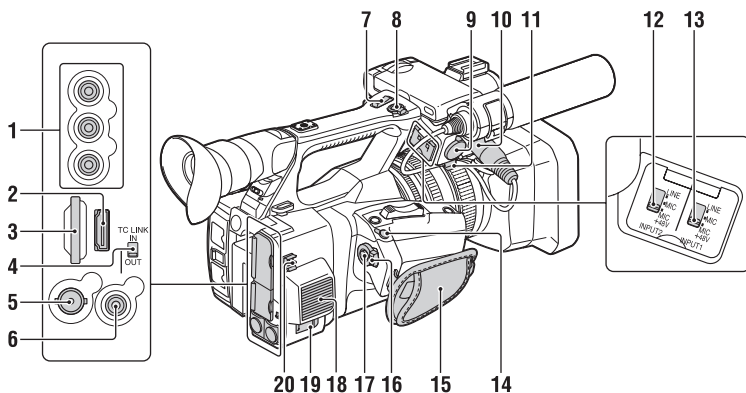



1. **AUDIO OUT connectors/VIDEO OUT connector (52, 63)**
2. **HDMI OUT connector (52)**
3. **UTILITY SD slot**
(Used for storing and loading the settings (File function), and to be supported by a future upgrade (software update).)
4. **TC LINK IN/OUT switch (32)**
5. **SDI OUT connector (52)**
6. **TC LINK connector**
7. **Handle zoom lever (25)**
8. **START/STOP button**
When the lever is set to the HOLD position, the START/STOP button is not operable.
9. **INPUT2 connector**
10. **INPUT1 connector (16)**
11. **Cable holder (16)**
Provided for securing a microphone cable, etc.
12. **INPUT2 switch (31)**
13. **INPUT1 switch (31)**
14. **REMOTE connector**
The REMOTE connector is used for controlling start/stop of recording, etc., on the video device and peripherals connected to it.
15. **Grip belt**
16. **POWER switch (25)**
17. **Record button (25)**
18. **Air outlet**
19. **DC IN connector (15)**
Do not cover the exhaust vents.
20. **Cable holder**
Provided for securing a DC cable, etc.

Notes

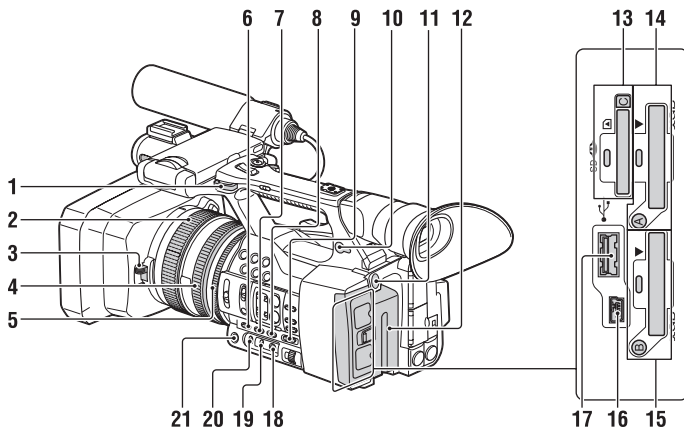
- Areas around the exhaust vents may become hot.



- 1. Hook for shoulder strap
- 2. Focus ring (26)
- 3. Lens cover lever (17)
- 4. Zoom ring (26)
- 5. Iris ring (28)
- 6. GAIN button (28)
- 7. WHT BAL button* (30)
- 8. SHUTTER SPEED button (29)
- 9. AUTO/MANUAL switch (28)
- 10.  (headphones) connector
For stereo mini-jack headphones
- 11. BATT RELEASE button (14)
- 12. Battery pack (14)
- 13. “Memory Stick” media/SD card C slot/
access lamp
(To be supported by future upgrade.)
- 14. XQD memory card A slot/select button/
access lamp (19)
- 15. XQD memory card B slot/select button/
access lamp (19)
- 16. USB connector (mini-B type) (53)
- 17.  USB connector (A type)
(To be supported by future upgrade.)
- 18.  (One push) button (29)
- 19. White balance memory switch (29)
- 20. Gain switch (28)
- 21. IRIS button* (28)

To attach a shoulder strap

Attach a shoulder strap (sold separately) to the hooks for a shoulder strap.

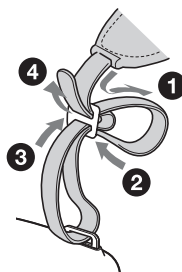

* WHT BAL and IRIS buttons have raised tactile dots for your convenience in locating the buttons.

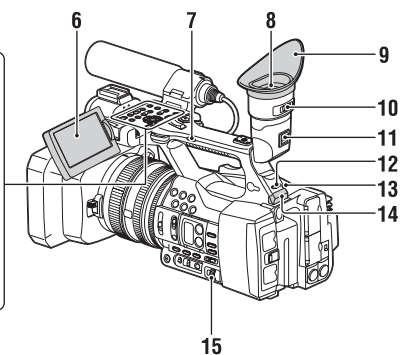
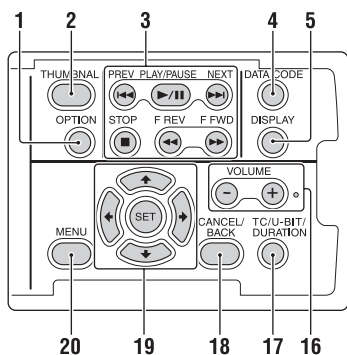

1. **OPTION button (36)**
2. **THUMBAL button (35)**
3. **Playback control buttons (PREV, PLAY/ PAUSE*, NEXT, STOP, F REV, F FWD) (27)**
4. **DATA CODE button**
(To be supported by future upgrade.)
5. **DISPLAY button (12)**
6. **LCD screen (17)**
7. **Handle zoom switch (25)**
8. **Viewfinder (18)**
9. **Large eyecup**
10. **Viewfinder lens adjustment lever (18)**
11. **Viewfinder release lever (59)**
12. **HEADPHONE MONITOR switch (32)**
13. **Rear recording lamp (49)**
14. **USB wireless LAN module retracting part (20)**
Connecting the supplied IFU-WLM3 USB wireless LAN module (supplied) allows communication with wireless LAN devices.
15. **SEL/SET dial buttons (39)**
16. **VOLUME buttons***
17. **TC/U-BIT/DURATION button**
(To switch between the timecode and recording time display on the LCD screen. The user bit will be supported by a future upgrade.)
18. **CANCEL/BACK button (39)**
19. **↕/↔/↔/SET buttons (39)**

20. MENU button (39)

* VOLUME+ button and PLAY/PAUSE button have raised tactile dots for your convenience in locating the buttons.

Bottom

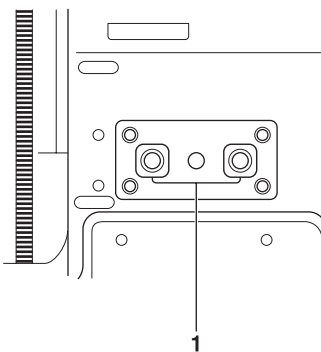

1. Tripod receptacle (1/4 inch)

This is a 1/4-20UNC screw compatible. Attach a tripod (sold separately) to the tripod receptacle using a tripod screw (sold separately: the length of the screw must be less than 5.5 mm (7/32 in.)).

Status screen

To display a status screen

- Press the STATUS CHECK button.

To switch status screens

- Turn the SEL/SET dial.

To hide the status screen

- Press the STATUS CHECK button.

Camera status screen

Displays the electronic shutter settings or the status of the lens.

Gain<H>	Setting value of Gain <H> level
Gain<M>	Setting value of Gain <M> level
Gain<L>	Setting value of Gain <L> level
Preset White	Preset value of white balance
Gamma	Gamma category and curve
AE Level	Setting value of AE level
AE Speed	Setting value of AE control speed
AGC Limit	Setting value of the maximum gain of AGC
A.SHT Limit	Fastest shutter speed of the auto shutter function

Audio status screen

Displays the input settings for each channel, audio level meter, and wind filter setting.

CH 1 level meter	Level meter for CH 1
CH 1 Source	Input source for CH 1
CH 1 Ref. / Sens.	Sensitivity of the internal microphone input to CH 1, or the reference level of audio input
CH 1 Wind Filter	Setting status of the wind filter for the microphone input to CH 1
CH 2 level meter	Level meter for CH 2
CH 2 Source	Input source for CH 2
CH 2 Ref. / Sens.	Sensitivity of the internal microphone input to CH 2, or the reference level of audio input
CH 2 Wind Filter	Setting status of the wind filter for the microphone input to CH 2
Audio Format	Audio format setting
Headphone Out	Headphone output setting

System status screen

Displays the video signal settings.

Country	Setting status of the region, NTSC region or PAL region
Rec Format	Recording format that is recorded on the XQD memory card
Picture Size	Picture size that is recorded on the XQD memory card

Frame Rate	Frame rate that is recorded on the XQD memory card
Rec Function	Special recording that is set to on, and its setting value

Video output status screen

Displays the SDI, HDMI, and video output settings.

SDI	Output picture size Output On/Off
HDMI	Output picture size Output On/Off
Video	Output picture size

Assignable button status screen

Displays the function that is assigned to each ASSIGN button.

1	Function that is assigned to the Assign 1 button
2	Function that is assigned to the Assign 2 button
3	Function that is assigned to the Assign 3 button
4	Function that is assigned to the Assign 4 button
5	Function that is assigned to the Assign 5 button
6	Function that is assigned to the Assign 6 button
7	Function that is assigned to the Assign 7 button

Media status screen

Displays the remaining space, available recording time, and estimated service life of the recording media (XQD memory card A/XQD memory card B).

Media information of Media A	Media icon displayed when recording media is inserted in the slot A
Protect information of Media A	Protect icon displayed when recording media inserted in the slot A is write-protected

Notes

- You cannot protect the XQD memory card on the camcorder.

Remaining meter of Media A	Remaining capacity of the recording media inserted in the slot A, expressed with a bar indicator
Remaining capacity of Media A	Remaining capacity of the recording media inserted in the slot A, expressed in GB

Media information of Media B	Media icon displayed when recording media is inserted in the slot B
Protect information of Media B	Protect icon displayed when recording media inserted in the slot B is write-protected
Remaining meter of Media B	Remaining capacity of the recording media inserted in the slot B, expressed with a bar indicator
Remaining capacity of Media B	Remaining capacity of the recording media inserted in the slot B, expressed in GB
Media information of the UTILITY SD card	Media icon displayed when recording media is inserted in the UTILITY SD slot
Protect information of the UTILITY SD card	Protect icon displayed when the UTILITY SD slot is write-protected
Remaining meter of the UTILITY SD card	Remaining capacity of the recording media inserted in the UTILITY SD slot, expressed by a bar indicator
Remaining capacity of the UTILITY SD card	Remaining capacity of the recording media inserted in the UTILITY SD slot, expressed in GB

On-Screen Indications

LCD/viewfinder screen

While recording, standing by to record, or playback, the statuses and settings of this unit are superimposed on the LCD/viewfinder screen.

The statuses and settings of this unit can be turned on/off using the DISPLAY button.

The statuses and settings of this unit can be independently turned on/off (*page 46*).

Information displayed on the screen while recording

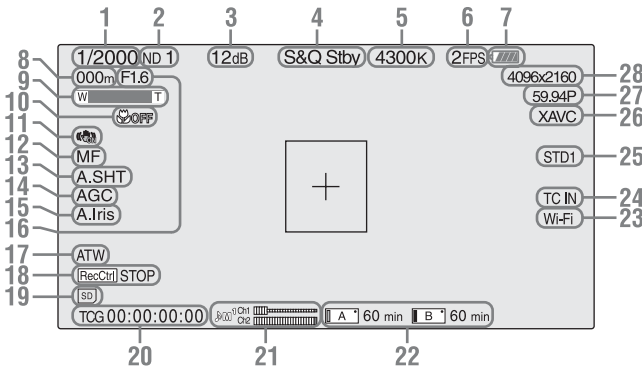

1. Shutter mode/shutter speed indication

2. ND filter indication (*page 29*)

3. Gain indication (*page 28*)

4. Special recording/operation status indication

● Rec	Recording in progress
Stby	Standby for recording
● S&Q Rec	Slow & Quick Motion recording in progress
S&Q Stby	Standby for Slow & Quick Motion recording

5. Color temperature indication (*page 29*)

6. S&Q motion frame rate indication (*page 47*)

7. Battery remaining indication (*page 57*)

8. Focus position indication

Displays focus position.

9. Zoom position indication

Displays zoom position in the range of 0 (wide position) to 99 (tele position)

10. Focus macro indication

11. SteadyShot indication

12. Focus mode indication

13. Auto shutter indication

14. AGC indication

15. Auto iris indication

16. Iris position indication

Displays iris position.

17. White balance mode indication (*page 29*)

ATW	Automatic mode
PWB	Preset mode
Memory A	Memory A mode
Memory B	Memory B mode
☀	Preset mode (indoor)
☀	Preset mode (outdoor)

18. Rec Control status of SDI output/HDMI output indication (*page 48*)

19. UTILITY SD slot media status indication

20. Time data indication (*page 32*)

21. Audio level meter

22. A/B slot media status/remaining space indication (page 19)

When the left side of the icon is orange, recording is possible.

When the green lamp on the upper right of the icon lights, playback is possible.

23. Wi-Fi connection status indication (page 20)

Displays the status when the Wi-Fi function is on.

24. TC IN connection status indication (page 47)

Displays the status when the timecode is input from an external device.

25. Gamma indication (page 42)

Displays the gamma setting value.

26. Recording format (codec) indication (page 28)

Displays the format that is recorded on an XQD memory card.

27. System frequency and scan method indication

28. Recording format (picture size) indication (page 28)

Displays the picture size that is recorded on an XQD memory card.

Information displayed on the playback screen

The following information is superimposed on the playback picture.

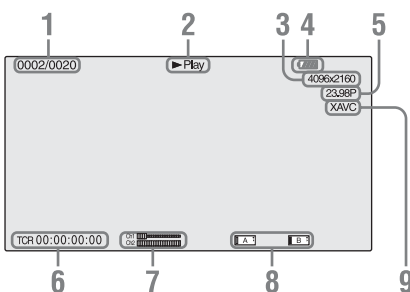

1. Clip no./total number of clips
2. Playback mode
3. Playback format (picture size)
4. Battery remaining
5. Playback format (frame rate)

6. Time data

The time data is displayed when the unit status/settings are displayed by pressing the DISPLAY button, and “Timecode” in “Display On/Off” of the LCD/VF menu is set to “On.”

7. Audio levels

The audio levels for the recording are displayed.

8. Media

A  mark appears to the left if the memory card is write-protected.

9. Playback format (codec)

Charging the battery pack

You can charge the “InfoLITHIUM” battery pack (L series) with the supplied Charger.

Notes

- You can use a large capacity battery pack, NP-F970 (supplied), with your camcorder. You cannot use NP-F570/F770 (sold separately).

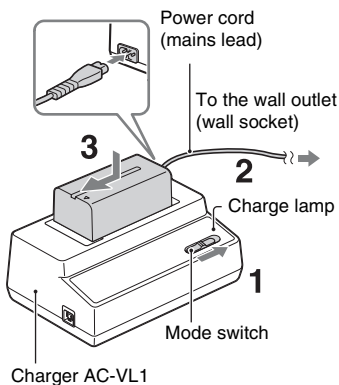

Notes

- You cannot use the AC-VL1 to connect the camcorder to an outside power source. When you connect the camcorder to a wall outlet (wall socket), use the supplied AC Adaptor.

- Set the mode switch to CHARGE.**
- Connect the power cord (mains lead) to the Charger and the wall outlet (wall socket).**
- Place the battery pack in the slot of the Charger, press it down, and slide it in the direction of the arrow.**
The charge lamp turns on and charging starts.

After charging the battery

The charge lamp turns off (normal charge). If you continue charging 1 more hour after the charge lamp turns off, you can use the battery a little longer (full charge).

Remove the battery pack from the Charger when the charge is completed.

Attaching the battery pack

Press the battery pack against the back of your camcorder and slide it down.

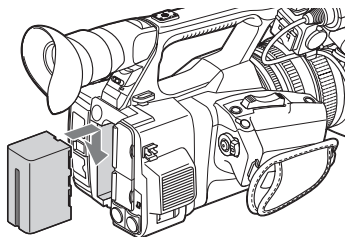

Removing the battery pack

Slide the POWER switch to OFF. Push the BATT RELEASE (battery release) button and remove the battery pack.

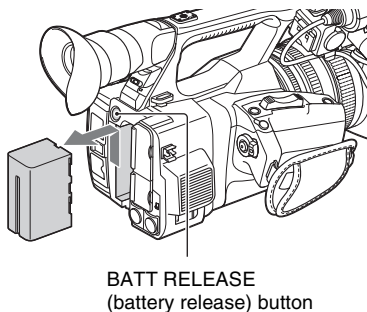

Notes

- Settings of the menu or settings adjusted using the AUTO/MANUAL switch can be saved when the POWER switch is set to OFF. Remove the battery pack after the display on the LCD/viewfinder screen has completely disappeared. Otherwise, changed settings may not be saved.
- If you remove the battery pack or AC Adaptor with the POWER switch ON, you cannot turn the camcorder on even though you attach the battery pack or AC Adaptor again. Slide the POWER switch to OFF temporarily, then to ON.

Storing the battery pack

If the battery pack is not in use for a while, run down the battery and store it. See *page 57* for details on storage of the battery pack.

Charging time

Approximate time (minute) required when you charge a fully discharged battery pack.

Battery pack	Normal charge time	Full charge time
NP-F970	365	425

Notes

- You cannot use the NP-F570/NP-F770 battery pack with your camcorder.

On the battery pack

- Before changing the battery pack, slide the POWER switch to OFF.

Using a wall outlet (wall socket) as a power source

You can use the AC Adaptor to obtain AC power.

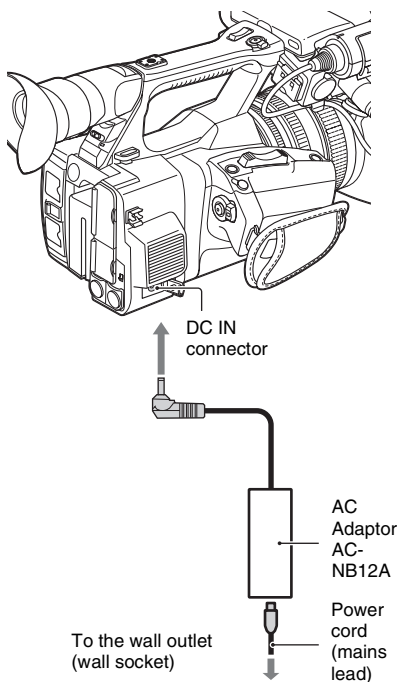

1. Connect the power cord (mains lead) to the AC Adaptor.
2. Connect the AC Adaptor to the DC IN jack of the camcorder.
3. Connect the power cord (mains lead) to the wall outlet (wall socket).

On the AC Adaptor

- Use the nearby wall outlet (wall socket) when using the AC Adaptor. Disconnect the AC Adaptor from the wall outlet (wall socket) immediately if any malfunction occurs while using your camcorder.
- Do not use the AC Adaptor placed in a narrow space, such as between a wall and furniture.
- Do not short-circuit the plug of the AC Adaptor with any metallic objects. This may cause a malfunction.
- Even if your camcorder is turned off, AC power (house current) is still supplied to it while connected to the wall outlet (wall socket) via the AC Adaptor.
- You cannot charge the camcorder by connecting it to the AC Adaptor.

Setting the Clock

When you turn the camcorder on for the first time after purchasing or the backup battery has completely discharged, the Initial Setting display appears on the viewfinder screen and LCD screen. Set the date and time of the built-in clock, using this display.

Time Zone

The value shows the time difference from UTC (Coordinated Universal Time). Change the setting if needed.

Setting the time and date

Clock starts after you turn the SEL/SET dial (page 9) to select the items or value, then press the SEL/SET dial to set them.

After the setting display disappears, “Clock Set” (page 50) in the System menu can be used to set “Time Zone” and date/time.

Notes

- If the clock setting is cleared because the backup battery fully discharged when no power was supplied (no battery pack and no DC IN connection), the Initial Setting display will be displayed when you next turn the camcorder on.
- While the Initial Setting display is shown, no other operation, except turning the power off, is permitted until you finish the setting for this display.

Attaching Devices

Attaching the supplied microphone

When you use the supplied microphone (ECM-XM1) for recording sound, do the following steps.

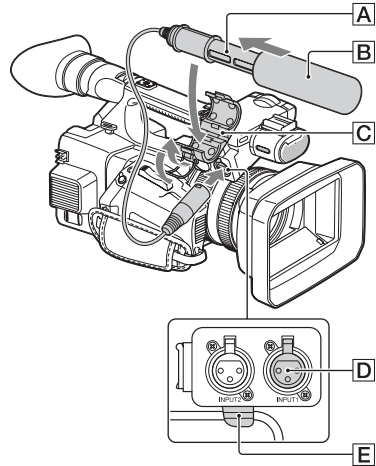

- 1 Attach the wind screen **B** to the supplied microphone **A**.
- 2 Place the microphone **A** in the microphone holder **C** with the model name facing upward, close the cover, and shut the clamper.
- 3 Connect the plug of the microphone to the INPUT1 connector **D**.
- 4 Put the microphone cable into the cable holder **E**.

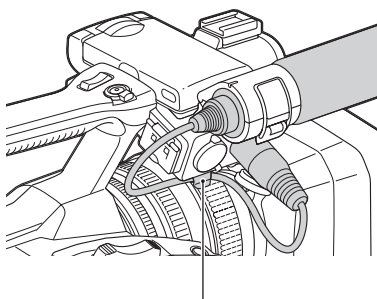

Hook the cable in the outer cable holder.

Attaching the lens hood with lens cover

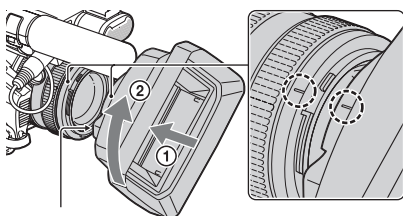

PUSH (lens hood release) button

Align the marks on the lens hood to those on the camcorder, and turn the lens hood in the direction of the arrow ② until it is locked.

Opening or closing the shutter of the lens hood with lens cover

Move the lens cover lever to OPEN to open the lens cover, and move the lever to CLOSE to close the lens cover.

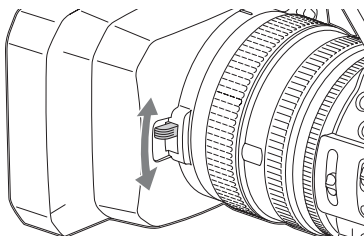

Removing the lens hood with lens cover

Turn the lens hood in the opposite direction to the arrow ② in the illustration while pressing the PUSH (lens hood release) button.

Notes

- Remove the lens hood with lens cover when you attach/detach a ϕ 72mm polarized filter or protective filter.

Adjusting the LCD screen and viewfinder

LCD screen

Open the LCD screen 180 degrees (①), then rotate it to the best angle to record or play back (②).

① Open 180 degrees.

② 90 degrees (max.)

② 180 degrees (max.)

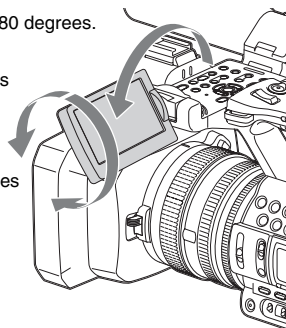

- Images are displayed as mirror images on the LCD screen, but are recorded as normal images.
- You can switch the brightness of the backlight of the LCD screen with “LCD Backlight” of “LCD Setting” in the LCD/VF menu (page 44).

Viewfinder

Viewfinder lens adjustment lever
Move it until the picture becomes clear.

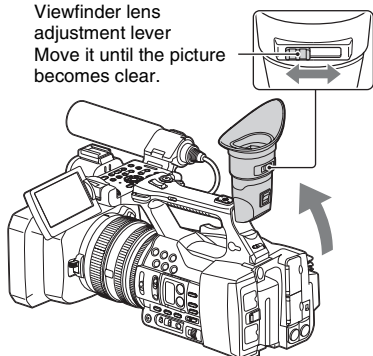

Notes

- You may see primary colors shimmering in the viewfinder when you move your line of sight. This is not a malfunction. The shimmering colors will not be recorded on the recording media.

You can switch the brightness of the viewfinder backlight with “VF Backlight” of “VF Setting” in the LCD/VF menu (*page 44*).

Using XQD Memory Cards

This camcorder records audio and video on XQD memory cards inserted in the card slots.

About XQD memory cards

Use the following Sony XQD memory cards.

XQD memory card S series (R/W: 180MB/s*)

* Use an XQD memory card with a description of Read / Write 180 MB/s.

You cannot use other XQD memory cards.

Operations are not guaranteed with other memory cards.

For details on using XQD memory cards and usage-related precautions, refer to the instruction manual for the XQD memory card.

Inserting an XQD memory card

- Open the cover of the card slot block.**
- Insert the XQD memory card until it clicks into place with the XQD label facing to the left.**

The access lamp (*page 8*) lights in red then changes to green once the memory card is ready for use.

- Close the cover.**

Notes

- If you insert a memory card into the slot in the wrong direction, the memory card, the memory card slot, or image data may be damaged.

Removing an XQD memory card

Open the cover of the card slot block, remove the XQD memory card by pressing the XQD memory card once lightly.

Notes

- Data integrity is not guaranteed if the power is turned off or a memory card is removed while it is being accessed. Data on the card may be destroyed. Be sure that its access lamp is lit in green or off when you turn off the power or remove a memory card.
- An XQD memory card removed from the camcorder after recording ended may be hot. This is not a malfunction.

Selecting the memory card slot to be used for recording

Press the A or B button of the memory card slot where the memory card you want to record on is inserted. The lamp of the selected slot lights up in green.

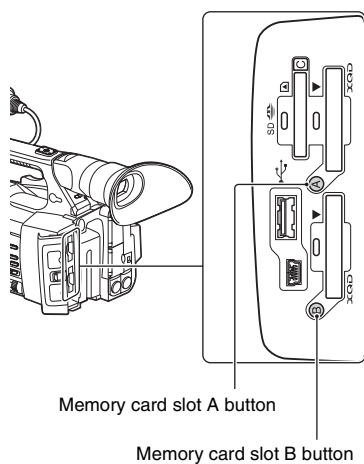
**Notes**

- You can only select a slot that already has a memory card inserted.
 - While movies are being recorded on the memory card, you cannot switch the slot even if you press the memory card slot A/B buttons.
-
- When only one slot has a memory card inserted, the slot that has the memory card is selected automatically.
 - If the memory card is fully recorded during recording, the camcorder continues recording automatically on the memory card inserted in the other slot.

Formatting an XQD memory card

If an XQD memory card is not formatted, or was formatted with another system, the message “Media Needs to be Formatted” is displayed on the LCD/viewfinder screen.

Format the card as follows.

Using “Format Media” (page 48) in the Media menu, specify “Media(A)” (slot A) or “Media(B)” (slot B) then select “Execute.” On a confirmation message, select “Execute” again.

The in-progress message and status bar are displayed, and the access lamp lights in red. When formatting is complete, a completion message is displayed. Press the SEL/SET dial to hide the message.

If formatting fails

A write-protected XQD memory card or memory card that cannot be used with this camcorder will not be formatted.

As a warning message is displayed, replace the card with an appropriate XQD memory card, according to the instructions in the message.

Notes

- All the data, including recorded pictures and setup files, are erased when a memory card is formatted.

Checking the remaining time available for recording

While recording (or standing by to record), you can check the remaining space for the XQD memory cards loaded in the card slots on the A/B slot media status/remaining space indication of the LCD screen/viewfinder screen (page 12). The available time for recording with the current video format (recording bit rate) is calculated according to the remaining space of each card and displayed in time units of minutes.

Notes

- A  icon appears if the memory card is write-protected.

Replacing an XQD memory card

- If the available time on two cards in total becomes less than 5 minutes, the warning message “Media Near Full” is displayed, the recording lamp flashes, and a beep sound is output to the headphones to warn you. Replace the cards with those that have sufficient space.
- If you continue recording until the total remaining time reaches zero, the message changes to “Media Full,” and recording stops.

Notes

- Up to approximately 600 clips can be recorded on one XQD memory card.
If the number of recorded clips reaches the limit, the remaining time indication becomes “0,” and the message “Media Full” is displayed.

Using a USB Wireless LAN Module

You can make the Wi-Fi connection between the camcorder and a device such as a smartphone, tablet, etc., by attaching the supplied IFU-WLM3 USB wireless LAN module.

Notes

- You cannot use a USB wireless LAN module other than the IFU-WLM3.

Making a Wi-Fi connection between a device and the camcorder enables you to do the following.

- Record and playback the camcorder
- Display the current status of the camcorder
- Switch between the recording settings and system settings
- Operate the assignable buttons of the camcorder
- Operate the iris, focus and zoom

Attaching the IFU-WLM3

- 1 **Open the cover of the USB wireless LAN module retracting part** (*page 9*).
- 2 **Insert the IFU-WLM3 to the USB connector.**
- 3 **Close the cover.**

Notes

- The IFU-WLM3 cannot be removed easily once attached. Use with the IFU-WLM3 attached.

Making a Wi-Fi connection

Notes

- Only one Wi-Fi device can be connected at a time.

Making a network setting

Change the “Basic Authentication” settings (*page 50*) of the System menu as required.

Item	Setting
User Name	User name for log-in (factory default setting: “admin”)
Password	Password for log-in (factory default setting: model name “pxw-z100”)

For details about the menu settings and entering a character string, see “Setup Menu Operations” (page 39).

Making a connection

- 1 Set “Wi-Fi” in “Wi-Fi” (page 50) of the System menu to “Enable.”
- 2 Make a Wi-Fi connection by inputting the SSID and Password onto the device, or by using the Wi-Fi direct connection function.
You can check the SSID and password of the camcorder on “SSID & Password” in “Wi-Fi” (page 50) of the System menu. When using the Wi-Fi direct connection function, proceed to the following step.
- 3 Select “Execute” for “Wi-Fi Direct Connection” in “Wi-Fi” of the System menu.

The setup menu disappears, and the connection wait message for the Wi-Fi direct connection function appears.

Using the Push-Button method

When you perform the Push-Button method on the device, the message for connection permission appears on the connection wait screen. Select “Execute.”

Using the PIN code method

When you perform the PIN code method on the device, the device name and PIN code appears on the connection wait screen. Complete the connecting process by inputting the PIN code to the device.

Using the Wi-Fi remote commander

When a Wi-Fi connection is established between a device such as smartphone, tablet, etc., and the camcorder, the Wi-Fi remote commander appears on the device screen and the device can be used as a remote commander.

You can start/stop recording and adjust the recording settings with a Wi-Fi connected device. This function is useful for setting the camcorder in a remote place, such as the top of a crane, etc.

Wi-Fi remote commander displays

Smartphone

Main screen

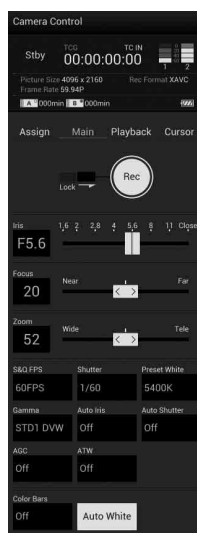

- Recording settings indication: S&Q FPS, Shutter, Preset White, Gamma, Auto Iris, Auto Shutter, AGC, ATW, Color Bars, Auto White

Playback screen

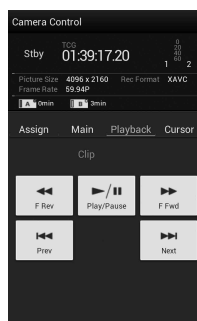

- Status indication
- Playback operation button: F Rev, Play/Pause, F Fwd, Prev, Stop, Next

Cursor screen

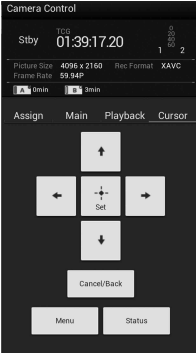

- Status indication
- Cursor operation button, menu/status indication:
Up, Left, Set, Right, Down, Cancel/Back, Menu, Status

Assign screen

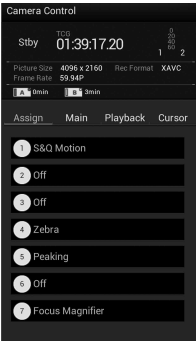

- Status indication
- Assignable button indication:
Assignable buttons 1 to 7

Tablet

Main screen

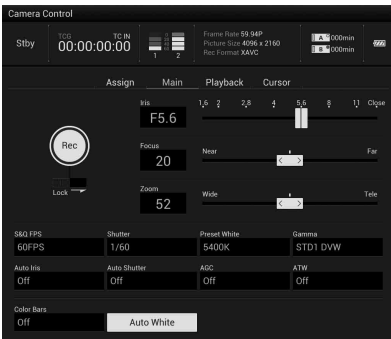

- Assignable button indication:
Assignable buttons 1 to 7
- Recording settings indication:
S&Q FPS, Shutter, Preset White, Gamma, Auto Iris, Auto Shutter, AGC, ATW, Color Bars, Auto White

Playback screen



- Status indication
- Assignable button indication
- Playback operation button:
F Rev, Play/Pause, F Fwd, Prev, Stop, Next

Cursor screen

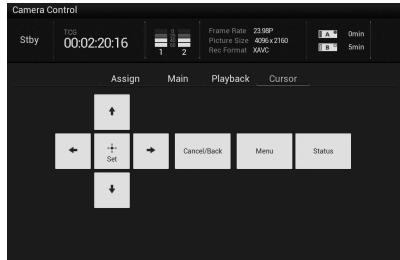

- Status indication
- Assignable button indication:
- Cursor operation button, menu/status indication:
Up, Left, Set, Right, Down, Cancel/Back, Menu, Status

Assign screen

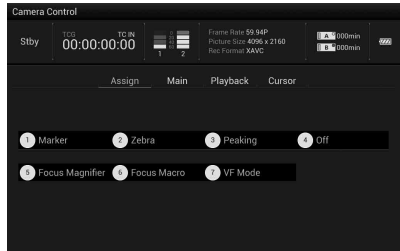

- Assignable button indication:
Assignable buttons 1 to 7

Displaying the Wi-Fi remote commander

The display size of the Wi-Fi remote commander changes according to the device screen size automatically.

1 Make a Wi-Fi connection between the device and camcorder (page 20).

2 Launch the browser and input `http://<camcorder's IP address>` (“System menu” > “Wi-Fi” > “IP Address”)/`rm.html` in the address bar.

Example: When the IP address is 10.0.0.1, input `http://10.0.0.1/rm.html` in the address bar.

3 Input the user name and password (“System menu” > “Basic Authentication” > “User Name” or “Password”) on the browser.

When completing the connection, the display of the Wi-Fi remote commander appears on the device.

Operate the Wi-Fi remote commander by following the display.

The REC button becomes unavailable when the Lock switch is dragged to the right.

Notes

- Depending on the device, the Wi-Fi remote commander may not appear properly on the device's screen even though you input `http://<camcorder's IP address>/rm.html` in the address bar. In this case, input “rms.html” for a smartphone or “rmt.html” for a tablet instead of “rm.html” at the end of the address to display the Wi-Fi remote commander properly.
- The Wi-Fi remote commander on the device's screen may no longer match the actual status of the camcorder in the following cases. When this happens, refresh the browser on the device.
 - when the camcorder is restarted while the Wi-Fi connection is established
 - when the camcorder is controlled directly while the Wi-Fi connection is established
 - when the device is reconnected
 - when you operate forward/backward on the device's browser.
- If the Wi-Fi signal is poor, the Wi-Fi remote commander may not work properly.

Compatible devices

The following devices, using the specified versions or higher, can be used as Wi-Fi remote commanders.

Device	OS	Browser
Smartphone	Android 4.0/4.1/4.2	Chrome V26
	iOS 5	Safari 5
	iOS 6	Safari 6
Tablet	Android 4.0/4.1/4.2	Chrome V26
	iOS 5	Safari 5
	iOS 6	Safari 6

Using a UTILITY SD card

You can store the setting value file of the camera on an SD card (optional). The stored file can be loaded from the SD card.

Usable SD Cards

SDHC memory card* (Speed Class: 4 to 10, UHS is not compatible, Capacity: 2 GB to 32 GB)
SD memory card* (File system: FAT 16, Capacity: up to 2 GB)

* Indicated as “SD card” in these Operating Instructions.

Inserting an SD Card

- 1 **Open the cover of the UTILITY SD/HDMI (page 7).**
- 2 **Insert the UTILITY SD memory card into the slot with the UTILITY SD label facing right.**
 The access lamp (page 8) lights in red then turns off when the memory card is ready for use.
- 3 **Close the cover.**

Removing an SD memory card

Open the cover of the card slot block, remove the SD card by pressing the SD card once lightly.

Notes

- Data integrity is not guaranteed if the power is turned off or a memory card is removed while it is being accessed. Data on the card may be destroyed. Be sure that its access lamp is off before you turn off the power or remove a memory card.
- Make sure that the card does not pop out when inserting or removing it.

Formatting an SD Memory Card

When you use an SD memory card with this camcorder, it must be formatted using the format function of this camcorder.

It is also necessary to format an SD memory card if a caution message is displayed when you mount it.

Using “Format Media” (page 48) in the Media menu, specify “SD card” then select “Execute.” On a confirmation message, select “Execute” again.

The in-progress message and status bar are displayed, and the access lamp lights in red. When formatting is complete, a completion message is displayed. Press the SEL/SET dial to hide the message.

Notes

- All the data are erased when a memory card is formatted, and the data cannot be restored.

Checking the Remaining Time

The remaining time can be checked on the media status screen (page 10).

Notes

- A  icon appears if the memory card is write-protected.

To use media formatted with this camcorder in the slots of other devices

Make a backup of the media, then format it using the other device.

Basic Operation Procedure

Basic recording can be performed with the following procedures.

- 1 Make sure that the necessary devices are attached to the camcorder and power is supplied to them.**
- 2 Load the memory card(s).**
If you load two cards, recording is continued by automatically switching to the second card when the first card becomes full.
- 3 Open the shutter of the lens hood with lens cover.**
- 4 Slide the POWER switch to ON while pressing the green button.**
The recording screen is displayed on the LCD/viewfinder screen.
- 5 Press the record button (page 7).**
The recording lamp lights and recording begins.
- 6 To stop recording, press the record button again.**
Recording stops and the camcorder enters STBY (recording standby) mode.

Adjusting the zoom

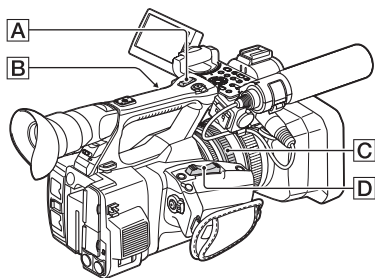

To use the power zoom lever

Move the power zoom lever **[D]** slightly for a slower zoom. Move it further for a faster zoom.

Wide view: (Wide angle)

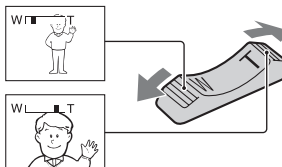

Close view: (Telephoto)

- The minimum distance required between your camcorder and the subject for focus is about 1 cm (about 13/32 in.) for wide angle and about 80 cm (about 2 5/8 feet) for telephoto.
- The focus may not be adjusted at certain zoom positions if the subject is within 80 cm (about 2 5/8 feet) from your camcorder.
- When “Focus Macro” in “Focus” of Camera menu is set to “Off,” you cannot focus on a subject within 80 cm (about 2 5/8 feet) regardless of the zoom position (page 40).
- Be sure to keep your finger on the power zoom lever **[D]**. If you move your finger off the power zoom lever **[D]**, the operation sound of the power zoom lever **[D]** may also be recorded.
- You can change the zoom speed of the power zoom lever **[D]** or the handle zoom lever **[A]** on “Setting” in “Speed Zoom” of the Camera menu (page 41).

To use the handle zoom

- Set the handle zoom switch **[B]** to VAR or FIX.
 - When you set the handle zoom switch **[B]** to VAR, you can zoom in or out at variable speed.
 - When you set the handle zoom switch **[B]** to FIX, you can zoom in or out at fixed speed, as set in “Setting” in “Handle Zoom” of the Camera menu (page 41).
- Press the handle zoom lever **[A]** to zoom in or out.

Notes

- You cannot use the handle zoom lever **A** when the handle zoom switch **B** is set to OFF.
- You cannot change the zoom speed of the power zoom lever **D** with the handle zoom switch **B**.

Using the zoom ring

You can zoom at the desired speed by turning the zoom ring **C**. Fine adjustment is also possible.

Notes

- Turn the zoom ring **C** at a moderate speed. If you turn it too fast, the zoom speed may lag behind the zoom ring rotation speed, or the operation sound of the zoom may also be recorded.

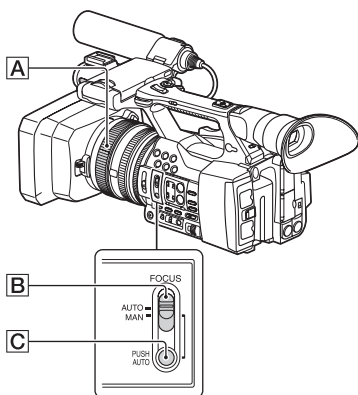
Adjusting the focus manually

You can adjust the focus manually for different recording conditions.

Use this function in the following cases.

- To record a subject behind a window covered with raindrops.
- To record horizontal stripes.
- To record a subject with little contrast between the subject and its background.
- When you want to focus on a subject in the background.

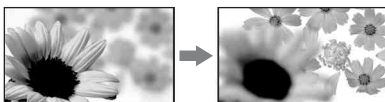

- To record a stationary subject using a tripod.

1 During recording or standby, set the FOCUS switch **B to MAN.**

The focus mode indication changes to “MF.”

2 Rotate the focus ring **A and adjust the focus.**

For focusing manually

- It is easier to focus on the subject when you use the zoom function. Move the power zoom lever towards T (telephoto) and adjust the focus, then, towards W (wide angle) to adjust the zoom for recording.
- When you want to record a close-up image of a subject, move the power zoom lever towards W (wide angle) to fully magnify the image, then adjust the focus.

To restore automatic adjustment

Set the FOCUS switch **B** to AUTO.

The focus mode indication changes to “AF” and the automatic focus adjustment is restored.

To use automatic focus temporarily (Push auto focus)

Record the subject while pressing and holding the PUSH AUTO button **C**.

If you release the button, the setting returns to manual focusing.

Use this function to shift the focus on one subject to another. The scenes will shift smoothly.

- The focal distance information (for when it is dark and hard to adjust the focus) appears for about 3 seconds in the following cases. (It will not be displayed correctly if you are using a conversion lens (sold separately)).

—When you rotate the focus ring while “MF” is displayed on the screen

To use the expanded focus (Expanded focus)

In the default setting, “Focus Magnifier” is assigned to the ASSIGN 7 button (*page 33*). Press the ASSIGN 7 button.

The focus magnifier screen appears and the center of the screen is magnified by about 2.0 times. It will be easier to confirm the focus setting during manual focusing. The screen returns to the original size when you press the button again.

Notes

- Even though the image appears expanded on the screen, the recorded image is not expanded.

Playing a recorded clip

You can play the recorded clip while the camcorder is in standby mode.

- 1 Insert the XQD memory card.**
- 2 Press the PLAY/PAUSE button of the playback control buttons.**
- 3 Search for the desired clip by pressing PREV or NEXT button.**
- 4 Press the PLAY/PAUSE button.**
The playback image appears on the viewfinder.

Playback operation is performed as follows.

PLAY/PAUSE button: Pauses playback. To resume playback, press this button again.

F FWD button/F REV button: Plays fast. To return to normal playback, press the PLAY/PAUSE button.

STOP button: Stops playback or recording.

Monitoring audio

In normal playback mode, you can monitor the recorded audio signals through the connected headphones.

You can select audio channel to be monitored and adjust the sound volume with “Audio Output” (page 43) in the Audio menu.

Cueing Up

To start playback from the top of the clip

Press the PREV button or NEXT button of the playback control buttons (page 9). You can cue to the top of a desired clip by pressing either button repeatedly.

Switching the XQD memory cards

When two memory cards are loaded, press the select button (page 8) to switch memory cards.

Notes

- You cannot switch XQD memory cards during playback.
Continuous playback of cards in slots A and B is not possible.

Clip (recording data)

When you stop recording, video, audio and subsidiary data from the start to end of the recording are recorded as a single clip on an XQD memory card.

Clip name

For each clip recorded with this camcorder, a clip name is automatically generated as “Clip” + a four-digit number.

The number is automatically incremented.

Maximum duration of a clip

The maximum clip length is 13 hours.

The maximum continuous recording time for a movie is approximately 13 hours. If recording time reaches approximately 13 hours, the recording will stop.

Changing Basic Settings

You can make changes to the settings based on the intended usage of the recorded video or recording conditions.

Recording format

Selectable format depends on the setting of the region where the camcorder is used (Country). To change the format, use “Video Format” in “Rec Format” (page 49) of the System menu.

Adjusting the image brightness

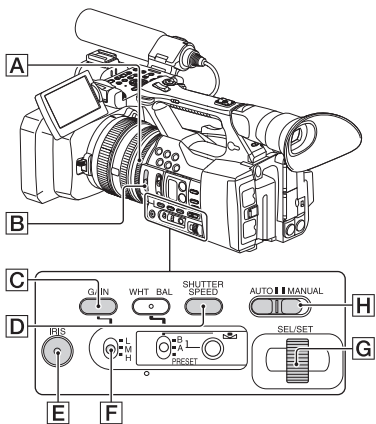

You can adjust the image brightness by adjusting the iris, gain or shutter speed, or by reducing the light volume with the ND FILTER switch [B].

Adjusting the iris

You can manually adjust the iris to control the volume of the light entering the lens. By adjusting the iris, you can change or close (CLOSE) the aperture of the lens, which is expressed as an F value between F1.6 and F11. The volume of the light increases the more that you open the aperture (decreasing F value). The volume of the light decreases the more that you close the aperture (increasing F value). The current F value appears on the screen.

1. During recording or standby, set the AUTO/MANUAL switch [H] to MANUAL.
 2. When the iris is automatically adjusted, press the IRIS button [E].
The iris value appears. When the iris value is automatically adjusted, “A.Iris” is displayed.
 3. Adjust the iris with the iris ring [A].
- The F value becomes close to F3.4 as the zoom position changes from W to T even when you open the aperture by setting the F value lower than F3.4, such as F1.6.
 - The range of focus, an important effect of the aperture, is called the depth of field. The depth of field gets shallower as the aperture is opened, and deeper as the aperture is closed. Use the aperture creatively to obtain the desired effect in your photography.
 - This is handy for making the background blurred or sharp.

To adjust the iris automatically

Press the IRIS button [E], or set the AUTO/MANUAL switch [H] to AUTO.

“A.Iris” is displayed next to the iris value.

Notes

- When you set the AUTO/MANUAL switch [H] to AUTO, other manually adjusted items (gain, shutter speed, white balance) also become automatic.

Adjusting the gain

You can adjust the gain manually when you do not want to use the AGC (automatic gain control).

1. During recording or standby, set the AUTO/MANUAL switch [H] to MANUAL.
2. When the gain is automatically adjusted, press the GAIN button [C].
“AGC” is displayed.
3. Set the gain switch [F] to H, M or L. The gain value set for the selected gain switch position appears on the screen. You can set the gain value for H/M/L from “Gain” of the Camera menu (page 40).

To adjust the gain automatically

Press the GAIN button [C], or set the AUTO/MANUAL switch [H] to AUTO.

The gain value disappears. “AGC” is displayed next to the gain value.

Notes

- When you set AUTO/MANUAL switch **[H]** to AUTO, other manually adjusted items (iris, shutter speed, white balance) also become automatic.

Adjusting the shutter speed

You can manually adjust and fix the shutter speed. You can make a moving subject look still or emphasize the movement of a moving subject by adjusting the shutter speed.

1. During recording or standby, set the AUTO/MANUAL switch **[H]** to MANUAL.
2. Press the SHUTTER SPEED button **[D]** to display the Shutter Value.
3. Change the Shutter Value displayed on the screen by turning the SEL/SET dial **[G]**.

You can adjust the shutter speed in a range of 1/4 second through 1/9000 second (NTSC Area) and 1/3 second through 1/9000 second (PAL Area).

The set Shutter Value appears on the screen. For example, “1/100” appears on the screen when you set the shutter speed to 1/100 second. The larger the denominator value on the screen, the faster the shutter speed.

4. Press the SEL/SET dial **[G]** to lock the Shutter Value.

To readjust the shutter speed, do steps 2 to 4.

- The shutter speed range that can be set depends on the frame rate.
- It is difficult to focus automatically at a lower shutter speed. Manual focusing with your camcorder attached to a tripod is recommended.
- When recording under fluorescent lamps, sodium lamps, or mercury lamps, the picture may flicker or change colors, or may have horizontal bands of noise. You may be able to improve the situation by adjusting the shutter speed.

To adjust the shutter speed automatically

Press the SHUTTER SPEED button **[D]** twice, or set the AUTO/MANUAL switch **[H]** to AUTO. The Shutter Value disappears. When the shutter speed is automatically adjusted, “A.SHT” is displayed.

Notes

- When you set the AUTO/MANUAL switch **[H]** to AUTO, other manually adjusted items (iris, gain, white balance) also become automatic.

Adjusting the volume of light (ND filter)

You can record the subject clearly by using the ND FILTER switch **[B]** when the recording environment is too bright.

OFF: ND filter is not used.

- 1: Reduce the amount of light to 1/4.
- 2: Reduce the amount of light to 1/16.
- 3: Reduce the amount of light to 1/64.

While the iris is automatically adjusted, the “Video Level Warning” is displayed.

If ND OFF flashes, set the ND FILTER switch to OFF. The ND filter icon will disappear from the screen.

Notes

- If you change the ND FILTER switch **[B]** during recording, the movie and sound may be distorted.
- When adjusting the iris manually, the “Video Level Warning” is not displayed even if the light volume should be adjusted with the ND FILTER switch.

While recording a bright subject, diffraction may occur if you close the aperture further down, resulting in a fuzzy focus (this is a common phenomenon with video cameras). The ND FILTER switch **[B]** suppresses this phenomenon and gives better recording results.

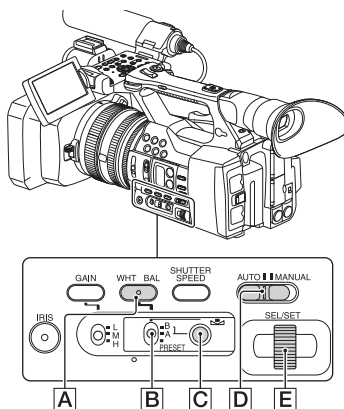
Adjusting to natural color (White balance)

You can adjust and fix the white balance according to the lighting conditions of recording environment.

You can store white balance values in memory A (☀️ A) and memory B (☀️ B), respectively.

Unless a white balance is readjusted, values will remain even after the power has been turned off. When you select PRESET, “Outdoor,” “Indoor” or “Color Temp.” is set, according to which one you previously selected with “Preset White” in “White” of the Paint menu.

1 During recording or standby, set the AUTO/MANUAL switch **[D]** to MANUAL.

2 Press the WHT BAL button **[A]**.

3 Set the white balance memory switch **[B]** to any one of PRESET/A/B.

Select A or B for recording with the white balance setting stored in memory A or B.

Indicator	Shooting conditions
☀️ A (Memory A)	<ul style="list-style-type: none"> White balance values adjusted for light sources can be stored in memory A and memory B.
☀️ B (Memory B)	<ul style="list-style-type: none"> Follow the steps in “To save the adjusted white balance value in memory A or B” (page 30).
☀️ Outdoor	<ul style="list-style-type: none"> Recording neon signs or fireworks Recording sunset/sunrise, just after sunset or just before sunrise Under daylight color fluorescent lamps
☀️ Indoor	<ul style="list-style-type: none"> Under the lighting conditions that change in many ways, such as a party hall Under strong light, such as in a photography studio Under sodium lamps or mercury lamps
Color temperature (“Color Temp.”)	<ul style="list-style-type: none"> Color temperature can be set between 2300K and 15000K (the default setting is 3200K).

- You can change the color temperature. Set “Color Temp.” in “Preset White” in “White” of the Paint menu, and the white balance memory switch **[B]** to PRESET, then press the **[M]** (one push) button **[C]**. Turn the SEL/SET dial **[E]** until the desired temperature appears on the screen, then press the dial to set the temperature. You can also set the color temperature by pressing the WHT BAL button **[A]** + **[M]** (one push) button **[C]**.

To save the adjusted white balance value in memory A or B

- Set the white balance memory switch to A (☀️ A) or B (☀️ B) in step 3 of “Adjusting to natural color (White balance).”
- Capture a white subject, such as white paper, full-screen in the same lighting condition as the one in which the subject is.
- Press the **[M]** (one push) button **[C]**. ☀️ A or ☀️ B starts flashing rapidly. It will stay on when the white balance adjustment is completed and the adjusted value is stored in ☀️ A or ☀️ B.

Notes

- It may take a long time to adjust the white balance, depending on the recording conditions. If you want to perform a different operation before completing the adjustment, set the white balance memory switch **[B]** to another position to temporarily suspend white balance adjustment.

To adjust the white balance automatically

Press the WHT BAL button **[A]** or set the AUTO/MANUAL switch **[D]** to AUTO.

Notes

- When you set the AUTO/MANUAL switch **[D]** to AUTO, other manually adjusted items (iris, gain, and shutter speed) also become automatic.

Audio setup

The following connectors, switches and dials allow you to set the sound to be recorded. See page 16 on connecting the microphones.

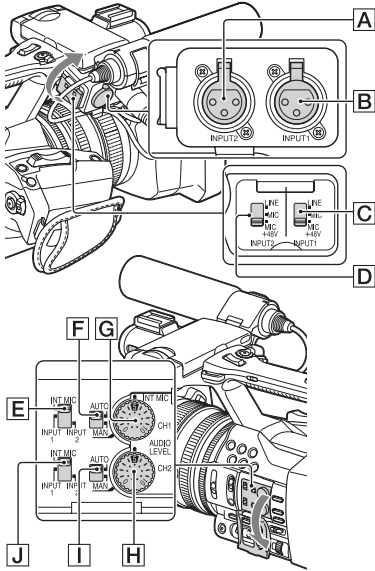

External audio input jacks and switches

INPUT 1 jack **B**

INPUT 2 jack **A**

INPUT 1 switch **C**

INPUT 2 switch **D**

Audio source switches

CH1 (INT MIC/INPUT 1/INPUT 2) switch **E**

CH2 (INT MIC/INPUT 1/INPUT 2) switch **J**

Audio level controls

CH1 (AUTO/MAN) switch **F**

CH2 (AUTO/MAN) switch **I**

AUDIO LEVEL (CH1) dial **G**

AUDIO LEVEL (CH2) dial **H**

Using the internal microphone

The sound will be recorded in stereo when using the internal microphone.

Set the CH1 (INT MIC/INPUT 1/INPUT 2) and CH2 (INT MIC/INPUT 1/INPUT 2) switches to INT MIC.

- If the recording level is low, set “INT MIC Sensitivity” in “Audio Input” of the Audio menu to “High” (page 43).
- To reduce wind roar, set “INT MIC Wind Filter” in “Audio Input” of the Audio menu to “On” (page 43).

Recording sound via the supplied microphone

The sound will be recorded in monaural.

1. Attach the supplied microphone (page 16) and connect it to the INPUT 1 jack **B**.
2. Set the CH1 (INT MIC/INPUT 1/INPUT 2) **E** and CH2 (INT MIC/INPUT 1/INPUT 2) **J** switches to INPUT 1.
The same sound will be recorded on both CH1 and CH2.
3. Set the INPUT 1 switch **C** to MIC+48V.

Recording sound from an external audio device

To use an external audio device, or a microphone other than the supplied microphone, change the following settings.

1. Select the input source.
Set the INPUT 1/INPUT 2 switches according to the devices connected to the INPUT 1/INPUT 2 jacks.

Audio devices	Switch position
External audio device (mixer, etc.)	LINE
Dynamic microphones or microphones with a built-in battery	MIC
+48V powering (Phantom powering) microphone	MIC+48V

- If you connect a device that does not support +48V phantom power, malfunction may result from setting this switch to MIC+48V. Check before connecting the device.
 - When there is no audio device connected to an INPUT jack, set the INPUT switch of that jack to LINE to prevent noise.
2. Set the input level of the microphone.

- Set the input level of the microphone by “INPUT1 Reference/INPUT2 Reference” in “Audio Input” of the Audio menu (page 43). Adjust according to the sensitivity of the microphone.
3. Select the channel you want to record. Using the CH1/CH2 switches, select the source to be recorded on each channel.

When the CH1 switch is set to INT MIC

Input source and recorded channel	CH2 switch setting
-----------------------------------	--------------------

INT MIC (L)	→ CH1	
INT MIC (R)	→ CH2	

INT MIC (mono)	→ CH1	
INPUT 1	→ CH2	

INT MIC (mono)	→ CH1	
INPUT 2	→ CH2	

When the CH1 switch is set to INPUT 1

Input source and recorded channel	CH2 switch setting
-----------------------------------	--------------------

INPUT 1	→ CH1	
INT MIC (mono)	→ CH2	

INPUT 1	→ CH1 → CH2	

INPUT 1	→ CH1	
INPUT 2	→ CH2	

- When the CH1 switch is set to INPUT 2, the INPUT 2 source is recorded to CH1.
- When you use a stereo microphone (2 XLR plugs), connect the L (left) channel plug to the INPUT 1 jack, and the R (right) channel plug to the INPUT 2 jack. Set the CH1 switch to INPUT 1, and the CH2 switch to INPUT 2.

Adjusting the volume

When both the CH1/CH2 switches are set to INT MIC, left and right channels are linked to the CH1 switch and dial.

1. Set the AUTO/MAN switch (F or I) of the channel to be adjusted to MAN. M_2 appears on the LCD screen.
2. During recording or standby, turn the AUDIO LEVEL dial (G or H) of the channel to be adjusted.

To restore automatic adjustment

Set the AUTO/MAN switch (F or I) of the manually adjusted channel to AUTO.

Setting the headphone sound

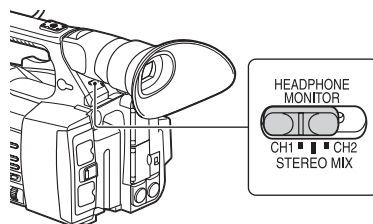

You can select the channel by setting the switch to CH1 or CH2, to output from the headphone. See “Headphone Out” in “Audio Output” of Audio menu on the sound at STEREO MIX (page 43).

Time data

Setting the Timecode

Specify the timecode to be recorded with “Timecode” in the TC/UB menu (page 47).

Synchronizing the timecode of your camcorder with that of another unit

Set the unit that supplies the timecode to a mode in which the timecode output keeps advancing (Free Run mode).

- 1 Set “Timecode” in the TC/UB menu as follows:

Mode: Preset
Run: Free Run

2 Confirm that the TC LINK IN/OUT switch (page 7) is set to IN, then supply the reference time code.

The built-in timecode generator of your camcorder locks to the reference timecode, and the message “TC IN” is displayed on the screen. Even if the reference timecode from the external device is disconnected, the external lock will be kept.

Notes

- If the frequency of the reference time code and the frame frequency are not the same, a lock cannot be acquired, and the camcorder will not operate properly. In such a case, the timecode will not be correctly locked to the external timecode.
- When the reference timecode is supplied, set the camcorder to standby.
- When the connection is removed, the timecode advance may shift some frames per hour with respect to the reference timecode.

To release the external timecode synchronization

Change the “Timecode” setting in the TC/UB menu.

External synchronization is also released when you start recording in a special recording mode.

Synchronizing the timecode of another unit with that of your camcorder

1 Set “Timecode” in the TC/UB menu as follows:

Mode: Preset

Run: Free Run

2 Confirm that the TC LINK IN/OUT switch (page 7) is set to OUT, then supply the reference timecode to another unit.

Notes

- When you set the frame rate of the recording format to 23.98P and the HDMI output setting to 1920×1080i or 720×480i, the timecode output of your camcorder is with the frame rate of 30 fps. If you want to output with the frame rate of 24 fps, change the settings of the HDMI output.

Useful Functions

Assignable buttons

The camcorder has seven assignable buttons (pages 5, 6) to which you can assign various functions for convenience.

Changing functions

Use “Assignable Button” (page 49) in the System menu.

The assigned functions can be viewed on the assignable button status screen (page 10).

Default assigned functions

Button 1	Off
Button 2	Off
Button 3	Off
Button 4	Zebra
Button 5	Peaking
Button 6	Off
Button 7	Focus Magnifier

Assignable functions

- Off
- Marker (page 45)
- Zebra (page 45)
- Peaking (page 44)
- Focus Magnifier (page 26)
- Focus Macro (page 40)
- VF Mode (page 49)
- Auto Exposure Level (page 40)
- SteadyShot (page 40)
- Color Bars (page 40)
- Rec Lamp[F] (page 49)
- Rec Lamp[R] (page 49)
- S&Q Motion (page 47)
- Thumbnail (page 51)

Slow & Quick Motion

When the video format (page 28) is set to the following setting, you can set the recording frame rate and playback frame rate to different values.
XAVC 1920 × 1080 29.97P/25P/23.98P

Shutter Value

If you change to Slow & Quick Motion mode when the Shutter Value is set to a time slower

than the one on the table below, the Shutter Value is changed to the value on the table automatically.

Frame rate	Shutter Value
23.98P	1/24
29.97P	1/30
25P	1/25
50P	1/50
59.94P	1/60

Notes

- Slow & Quick Motion mode cannot be used while recording, playing, or displaying thumbnail.
- Audio cannot be recorded while in the Slow & Quick Motion mode.

Thumbnail Screens

Thumbnail Screens

When you press the THUMBNAIL button (*page 9*), clips recorded on the XQD memory card are displayed as thumbnails on the screen.

You can start playback from the clip selected on the thumbnail screen. The playback picture can be seen on the LCD/viewfinder screen and external monitors.

Press the THUMBNAIL button to exit the thumbnail screen and return to the recording screen.

Configuration of the screen

Information for the clip selected with the cursor are displayed at the bottom of the screen.

The icon of the current XQD memory card is highlighted, shading the nonselected one. (If the card is write-protected, a lock icon is displayed to the right.)

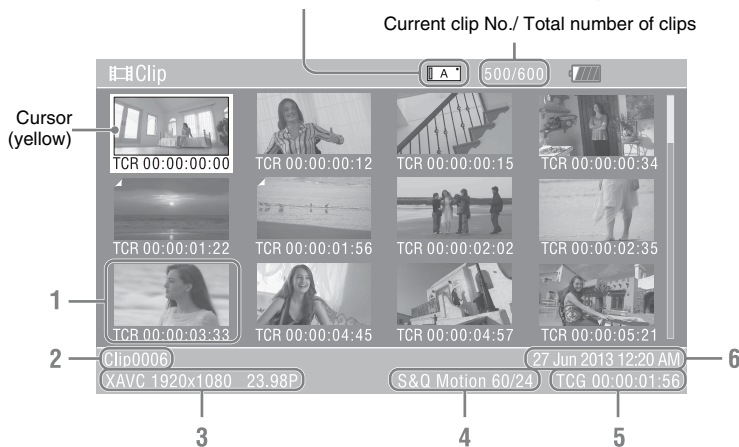

1. Thumbnail

The thumbnail image for each clip is an index frame from the clip. When recording, the first frame of a clip is automatically set as the index frame.

Below each thumbnail, the clip/frame information is displayed. You can change the displayed item on “Thumbnail Caption” in “Customize View” (*page 36*) of the thumbnail menu.

2. Clip name

The clip name of the selected clip is displayed.

3. Recording video format

The file format of the selected clip is displayed.

4. Special recording information

If the selected clip was recorded in a special recording mode, the mode is displayed. Clips recorded in Slow & Quick Motion display the frame rate to the right.

5. Duration of the clip

6. Creation date and time

Playing Clips

Playing the selected and subsequent clips in sequence

- 1 Turn the SEL/SET dial (*page 9*) to move the cursor to the thumbnail image of the clip with which you wish to start playback.
- 2 Press the SEL/SET dial.
Playback starts from the beginning of the selected clip.

Notes

- The playback picture may be momentarily distorted or frozen between clips. You cannot operate the camcorder during this condition.
- When you select a clip on the thumbnail screen and start playback, the playback picture at the beginning of the clip may be distorted. To start playback without distortion, pause playback once after starting it, press the PREV button of the playback control buttons to return to the top of the clip, then restart playback.

Clip Operations

On the thumbnail screen, you can operate the clips or confirm the subsidiary data for clips using the thumbnail menu. The thumbnail menu appears when you press the OPTION button (*page 9*) on the thumbnail screen.

Operations of the thumbnail menu

Turn the SEL/SET dial (*page 9*) to select a menu item, then press the SEL/SET dial. Pressing the CANCEL/BACK button (*page 9*) restores to the previous condition. Pressing the OPTION button while the thumbnail menu is displayed turns the thumbnail menu off.

Notes

- When the XQD memory card is write-protected, some operations are unavailable.
- There may be items that cannot be selected, depending on the status when the menu is displayed.

Clip operation menu

Display Clip Properties

Displays the detailed information of a clip screen (*page 37*).

Delete Clip

Select Clip: Deletes the selected clip (*page 38*).

Delete All Clips

Select Clip: Deletes all clips (*page 51*).

Customize View

Thumbnail Caption: Changes the items that are displayed under the thumbnail image. (*page 38*)

Displaying the detailed information of a clip

Select "Display Clip Properties" from the thumbnail menu.

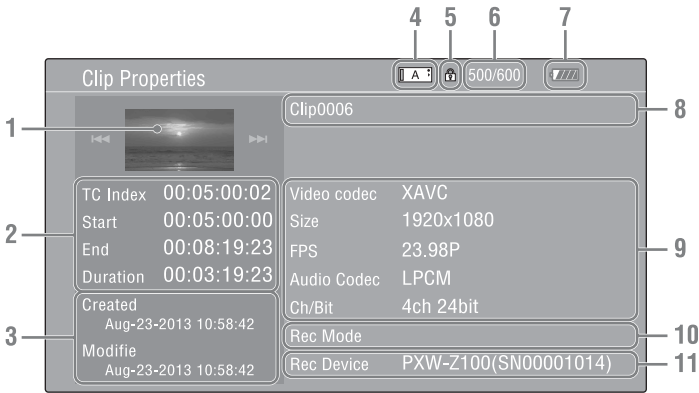

1. Image of the current clip

2. Timecode

TC Index: Timecode of the displayed frame
Start: Timecode at the recording starting point
End: Timecode at the recording ending point
Duration: Duration of the clip

3. Date of recording/modifying

4. Currently selected memory card

5. Media protect icon

6. Clip number/Total number of clips

7. Battery icon

8. Clip name

9. Recording format

Video Codec: Video codec
Size: Picture size
FPS: Frame rate/bit-rate
Audio Codec: Audio codec
Ch/Bit: Number of the recorded audio channel/
audio recording bit

10. Special recording information

11. Recording device name

Deleting clips

You can delete clips from the XQD memory card. Select “Select Clip” from “Delete Clip” on the thumbnail menu.

You can select multiple clips to be deleted. Press the OPTION button (*page 9*) after selecting the clip to be deleted.

Changing information on the thumbnail screen

You can change information of the clip/frame that is displayed under thumbnail.

Select the displayed item from “Thumbnail Caption” in “Customize View” on the thumbnail menu.

Date Time: Creation date or modified time

Time Code: Timecode

Duration: Duration

Sequential Number: Thumbnail number

Settings

Setup Menu Operations

The Setup menu allowing you to perform various settings that are needed for recording and playing, appears on the LCD/viewfinder screen by pressing the MENU button. (You can display the Setup menu on the external video monitor.)

Menu controls

MENU button (page 9)

To turn the menu mode to use the setup menus on/off.

SEL/SET dial (page 9)

When you turn the dial, the cursor moves up or down, permitting you to select menu items or setting values.

Press the SEL/SET dial to select the highlighted item.

CANCEL/BACK button (page 9)

To return to the previous menu. An uncompleted change is canceled.

▲/▼/◀/▶ SET button

When you press the ▲/▼/◀/▶ buttons, the cursor moves in the corresponding direction, permitting you to select menu items or setting values.

Press the SET button to enter the highlighted item.

Notes

- In Focus Magnifier mode (page 26), the setup menu cannot be used.

Setting the Setup menus

Turn the SEL/SET dial to set the cursor to the item of the menu you wish to set, then press the SEL/SET dial to select that item.

- The menu item selection area can show 9 lines at maximum. When all the selectable items cannot be displayed at one time, you can scroll the display up or down by moving the cursor.
- For items having a wide range of available values (example: -99 to +99), the available value area is not displayed. The current setting is highlighted instead, indicating that the setting is ready for change.
- When you select “Execute” for an execution item, the corresponding function is executed.

- When you select an item that you must confirm before execution, the menu display temporarily disappears, and a confirmation message is displayed. Follow the instructions of the message, and specify whether to execute or cancel.

Entering a character string

When you select an item for which a character string, such as a filename, is to be specified, the character input screen appears.



1 Select character type by turning the SEL/SET dial, then press the SEL/SET dial to enter.

ABC: Uppercase alphabetical
abc: Lowercase alphabetical
123: Numerical
!#\$: Special

2 Select a character from the selected character type.

The cursor moves to the next column.
Space: Inputs space on the position of the cursor.
◀/▶: Moves the cursor.
BS: Deletes a character on the left of the cursor.

3 Select “Done” after inputting characters.

The input characters are entered and the character input screen disappears.

Setup Menu List

The functions and available settings of menus are listed below.

The default settings set at the factory are shown in bold face (example: **18dB**).

Camera menu

Camera		
Menu items	Sub items and setting values	Contents
Gain Setting for the gain	Gain<H> 0dB / 3dB / 6dB / 9dB / 12dB / 15dB / 18dB / 21dB	Sets the preset value <H> of the gain.
	Gain<M> 0dB / 3dB / 6dB / 9dB / 12dB / 15dB / 18dB / 21dB	Sets the preset value <M> of the gain.
	Gain<L> 0dB / 3dB / 6dB / 9dB / 12dB / 15dB / 18dB / 21dB	Sets the preset value <L> of the gain.
Auto Exposure Setting for the total level control system	Level -2.0 / -1.75 / -1.5 / -1.25 / -1.0 / -0.75 / -0.5 / -0.25 / 0 / +0.25 / +0.5 / +0.75 / +1.0 / +1.25 / +1.5 / +1.75 / +2.0	Sets the TLCS level.
	Speed -99 to +99 (±0)	Sets the control speed of the TLCS.
	AGC Limit 3dB / 6dB / 9dB / 12dB / 15dB / 18dB / 21dB / 24dB	Sets the maximum gain of the AGC function.
	A.SHT Limit Off / 1/100 / 1/150 / 1/200 / 1/250	Sets the fastest shutter speed for the auto shutter function.
Focus Setting for the focus	Focus Macro On / Off	Sets whether to include the macro area in the moving range of the focus position.
Color Bars Setting for the color bars	Setting On / Off	Turns the color bars on/off.
	Type ARIB / SMPTE / 75% / 100%	Selects the type of color bar.
Flicker Reduce Setting for the flicker correction	Mode Auto / On / Off	Sets the flicker correction mode.
	Frequency 50Hz / 60Hz	Sets the power frequency of lights that cause the flicker.
SteadyShot Setting for the SteadyShot function	Setting On / Off	Turns on/off the SteadyShot function.
	SteadyShot Type Hard / Standard / Soft / Wide Conversion	Selects the SteadyShot type.

Camera		
Menu items	Sub items and setting values	Contents
Handle Zoom Setting for the handle zoom speed	Setting 1 to 8 (3)	Sets the handle zoom speed. (This setting is available only when the handle zoom switch is set to "FIX.")
	Speed Zoom Setting for the fast zoom function	Setting On / Off

Paint menu

Paint		
Menu items	Sub items and setting values	Contents
White Setting for white balance	Preset White Outdoor / Indoor / Color Temp.	Selects the type to be used as the preset.
	Color Temp. <Preset> 2300K to 15000K (3200K)	Displays and sets the color temperature of white balance that is stored in the white memory.
	Shockless White Off / 1 / 2 / 3	Sets the speed of change in white balance when the white balance mode is switched. Off: Changes instantly. 1 to 3: Select a larger number to change the white balance more slowly through interpolation.
	ATW Speed 1 / 2 / 3 / 4 / 5	Sets the reaction speed when in ATW mode. 1: Fastest reaction speed
Offset White Setting for the offset white balance	Setting On / Off	Turns on/off "Offset White" that is for the auto white balance (one push) and ATW function.
	Offset<A> -99 to +99 (±0)	Adjusts the volume of the offset white for the white memory (A).
	Offset -99 to +99 (±0)	Adjusts the volume of the offset white for the white memory (B).
	Offset<ATW> -99 to +99 (±0)	Adjusts the volume of the offset white for the ATW.
Black Setting for the black	Setting On / Off	Turns on/off the black correction.
	Master Black -99 to +99 (±0)	Sets the master black level.
	R Black -99 to +99 (±0)	Sets the R black level.
	B Black -99 to +99 (±0)	Sets the B black level.

Paint		
Menu items	Sub items and setting values	Contents
Gamma Adjusting the gamma compensation	Gamma Category STD / CINE	Select from among “STD” (standard gamma), “CINE.”
	Gamma Select	Selects the gamma table that is used for the gamma compensation. When “Gamma Category” is set to “STD” STD1 DVW / STD2 ×4.5 / STD3 ×3.5 / STD4 240M / STD5 R709 / STD6 ×5.0 When “Gamma Category” is set to “CINE” Cinematone1 / Cinematone2
Knee Adjusting the knee compensation	Setting On / Off	Turns the knee compensation function on/off. (This setting is available only when “Gamma Category” in “Gamma” is set to “STD.”)
	Auto Knee On / Off	Turns on/off the auto knee function.
	Point 75% to 109% (90%)	Sets the knee point.
	Slope -99 to +99 (±0)	Sets the knee slope.
Detail Setting for the detail adjusting	Manual Setting On / Off	Turns the detail adjusting function on/off.
	Level -99 to +99 (±0)	Adjusts the detail level.
	H/V Ratio -99 to +99 (±0)	Adjusts the ratio between the H detail level and V detail level.
	Crispensing -99 to +99 (±0)	Adjusts the crispensing level.
	White Limit -99 to +99 (±0)	Adjusts the white detail limiter.
	Black Limit -99 to +99 (±0)	Adjusts the black detail limiter.
Skin Detail Adjusting the skin detail compensation	Setting On / Off	Turns the skin detail compensation function on/off.
	Area Detection Execute/Cancel	Detects the color for the skin detail compensation. Execute: Executes this function.
	Area Indication On / Off	Turns on/off the function that displays the zebra pattern in the target area for the skin detail compensation.
	Level -99 to +99 (±0)	Adjusts the skin detail level.
	Saturation -99 to +99 (±0)	Adjusts the color (saturation) level for the skin detail compensation.
	Hue 0 to 359	Adjusts the color hue for the skin detail compensation.
	Width 0 to 90 (40)	Adjusts the width of the color hue for the skin detail compensation.

Paint		
Menu items	Sub items and setting values	Contents
Matrix Setting for the Matrix correction	Setting On / Off	Turns the matrix correction function on/off.
	Preset Matrix On / Off	Turns the preset matrix function on/off.
	Preset Select Standard / High Saturation / FL Light / Cinema	Selects the preset matrix.
	User Matrix On / Off	Turns the user matrix correction function on/off.
	Level -99 to +99 (± 0)	Adjusts the color saturation for the entire picture area.
	Phase -99 to +99 (± 0)	Adjusts the color phase for the entire picture area.

Audio menu

Audio		
Menu items	Sub items and setting values	Contents
Audio Input Setting for audio inputs	INPUT1 Reference -60dB / -50dB / -40dB	Selects the reference input level for when the INPUT1 switch is set to MIC.
	INPUT2 Reference -60dB / -50dB / -40dB	Selects the reference input level for when the INPUT2 switch is set to MIC.
	INT MIC Sensitivity Normal / High	Selects the sensitivity of the internal microphone.
	INPUT1 Wind Filter On / Off	Turns on/off the wind filter for CH1.
	INPUT2 Wind Filter On / Off	Turns on/off the wind filter for CH2.
	INT MIC Wind Filter On / Off	Turns on/off the wind filter for the internal stereo microphone.
	Limiter Mode On / Off	Turns the limiter on/off when a loud signal is input while setting audio input level manually.
	AGC Mode Mono / Stereo	Selects the cross-channel linkage of the AGC.
	1KHz Tone On / Off	Turn the 1-kHz reference tone signal on/off.
	Audio Output Setting for audio outputs	Headphone Out Mono / Stereo

Video menu

Video		
Menu items	Sub items and setting values	Contents
Output On/Off Setting for the video output	SDI On / Off	Turns the SDI output on/off.
	HDMI On / Off	Turns the HDMI output on/off.
Output Format Setting for the output format • Limitations of output formats (page 61)	SDI 2048×1080P / 1920×1080P / 1920×1080i / 1280×720P / 720×486i / 720×576i	Sets the resolution of the SDI output. SET: Execute this function.
	HDMI 4096×2160P / 3840×2160P / 1920×1080P / 1920×1080i / 720×480P / 720×576P	Sets the resolution of the HDMI output. SET: Execute this function.
	VIDEO	Displays the resolution and scan method. (Display only)
	SDI On / Off	Selects whether to add the menu or status on the SDI output signal.
Output Display Setting for the output signal	HDMI On / Off	Selects whether to add the menu or status on the HDMI output signal.
	VIDEO On / Off	Selects whether to add the menu or status on the video output signal.

LCD/VF menu

LCD/VF		
Menu items	Sub items and setting values	Contents
LCD Setting Setting for the LCD screen	Color -99 to +99 (±0)	Adjusts the color saturation of the LCD screen.
	Brightness -99 to +99 (±0)	Adjusts the brightness of the LCD screen.
	LCD Backlight Normal / Bright	Adjusts the backlight level of the LCD screen.
VF Setting Setting for the viewfinder	VF Backlight Normal / Bright	Adjusts the brightness of pictures on the viewfinder.
	Color Mode Color / B&W	Selects the display mode of the viewfinder while E-E display/recording.
	Power Mode Auto / On	Sets the lighting mode according to the LCD screen. Auto: Lights when the LCD is closed or inverted. On: Always lights
Peaking Setting for the peaking function	Setting On / Off	Turns the peaking function on/off.
	Color White / Red / Yellow / Blue	Selects the signal color of the color peaking.
	Color Peaking Level 0 to 99 (50)	Sets the color peaking level.

LCD/VF		
Menu items	Sub items and setting values	Contents
Marker Setting for the marker indications	Setting On / Off	Turn all marker indications on the viewfinder on/off.
	Center Marker On / Off	Turns on/off the center marker.
	Safety Zone On / Off	Turns the safety zone marker on/off.
	Safety Area 80% / 90% / 92.5% / 95%	Selects the size (ratio to the entire screen) of the safety zone marker.
	Aspect Marker On / Off	Turns on/off the aspect marker.
	Aspect Select 4:3 / 13:9 / 14:9 / 15:9 / 16:9	Select the ratio of the aspect marker.
	Guide Frame On / Off	Turns on/off the guide frame display.
Zebra Setting for the zebra pattern	Setting On / Off	Turns the zebra function on/off.
	Zebra Select 1 / 2 / Both	Select the zebra pattern(s) (Zebra 1, Zebra 2, or both of Zebra 1 and Zebra 2) to be displayed.
	Zebra1 Level 50% to 107% (70%)	Sets the display level of zebra 1.
	Zebra1 Aperture Level 1% to 20% (10%)	Sets the aperture level of zebra 1.
	Zebra2 Level 52% to 109% (100%)	Sets the display level of zebra 2.

Menu items	Sub items and setting values	Contents
Display On/Off Selecting the items to be displayed	Shutter Setting On / Off	Selects the item to be displayed on the LCD screen or the viewfinder.
	ND Filter Position On / Off	
	Gain Setting On / Off	
	Play Status On / Off	
	Color Temp. On / Off	
	Frame Rate On / Off	
	Battery Remain On / Off	
	Timecode On / Off	
	Audio Manual On / Off	
	Audio Level Meter On / Off	
	Media Status On / Off	
	Focus Position Meter / Feet / Off	
	Iris Position On / Off	
	Zoom Position Number / Bar / Off	
	Focus Macro On / Off	
	SteadyShot On / Off	
	Focus Mode On / Off	
	Auto Shutter On / Off	
	AGC On / Off	
	Auto Iris On / Off	
	AE Mode On / Off	
	White Balance Mode On / Off	
	SDI/HDMI Rec Control On / Off	

LCD/VF		
Menu items	Sub items and setting values	Contents
	Rec Format	
	On / Off	
	Gamma	
	On / Off	
	TC IN	
	On / Off	
	Audio Format	
	On / Off	
	Wi-Fi Condition	
	On / Off	
	Video Level Warning	
	On / Off	
	Clip Number	
	On / Off	

TC/UB menu

TC/UB		
Menu items	Sub items and setting values	Contents
Timecode Setting the timecode	Mode	Selects the timecode mode.
	Preset / Regen	Preset: To start the timecode from the specified value Regen (regeneration): To start the timecode by continuing the timecode of the previous clip.
	Run	Rec Run: To advance the timecode during recording only. Free Run: The timecode keeps advancing regardless of the state of recording.
	Rec Run / Free Run	
	Setting	Sets the timecode to a desired value. SET: Sets the value.
	Reset	Resets the timecode to 00:00:00:00.
	Execute / Cancel	Execute: Execute this function.
	TC Format	Selects the timecode format.
	DF / NDF	DF: Drop frame NDF: Non drop frame

Recording menu

Recording		
Menu items	Sub items and setting values	Contents
S&Q Motion Setting the Slow & Quick motion mode	Setting	Turns the Slow & Quick motion mode on/off.
	On / Off	
	Frame Rate	Sets the frame rate during shooting with the Slow & Quick motion function when S&Q setting is "On."
	NTSC Area: 1P, 2P, 4P, 8P, 15P, 30P, 60P	
	PAL Area: 1P, 2P, 3P, 6P, 12P, 25P, 50P	

Recording

Menu items	Sub items and setting values	Contents
SDI/HDMI Rec Control Setting the SDI/HDMI recording control function	Setting On / Off	Turns on/off this function that controls recording/stop recording of the external device by the SDI/HDMI output signal.

Media menu

This menu is not available when the media is not loaded.

Media

Menu items	Sub items and setting values	Contents
Format Media Formatting a memory	Media(A) Execute / Cancel	Formats the XQD memory card in the slot A. Execute: Executes format.
	Media(B) Execute / Cancel	Formats the XQD memory card in the slot B. Execute: Executes format.
	SD card Execute / Cancel	Formats the UTILITY SD card Execute: Executes format.

File menu

File

Menu items	Sub items and setting values	Contents
All File Setting for the All file	Load SD Card Execute / Cancel	Loads the All file. Execute: Executes this function.
	Save SD card Execute / Cancel	Stores the All file. Execute: Executes this function.

System menu

System			
Menu items	Sub items and setting values	Contents	
Rec Format Setting the recording format	Video Format	Sets the recording format.	
	NTSC Area:	SET: Execute this function.	
	4096×2160 59.94P		
	4096×2160 29.97P		
	4096×2160 23.98P		
	3840×2160 59.94P		
	3840×2160 29.97P		
	3840×2160 23.98P		
	1920×1080 59.94P		
	1920×1080 29.97P		
	1920×1080 23.98P		
	PAL Area:		
	4096×2160 50P		
	4096×2160 25P		
3840×2160 50P			
3840×2160 25P			
1920×1080 50P			
1920×1080 25P			
Assignable Button Assigning functions to the assignable buttons	<1> to <7>	Assign a function to the assignable buttons.	
	Off / Marker / Zebra / Peaking / Focus Magnifier / Focus Macro / VF Mode / Auto Exposure Level / SteadyShot / Color Bars / Rec Lamp[F] / Rec Lamp[R] / S&Q Motion / Thumbnail	Marker: Turns the marker on/off. Zebra: Turns the zebra function on/off. Peaking: Turns the peaking function on/off. Focus Magnifier: Turns the focus magnifier function on/off. Focus Macro: Turns the focus macro function on/off. VF Mode: Switches between color and mono display on the viewfinder. Auto Exposure Level: Turns the auto exposure level function on/off. SteadyShot: Turns the SteadyShot function on/off. Color Bars: Turns the color bars display on/off. Rec Lamp[F]: Turns the front recording lamp on/off. Rec Lamp[R]: Turns the rear recording lamp on/off. S&Q Motion: Turns the Slow & Quick motion function on/off. Thumbnail: Turns the thumbnail display on/off.	
	Rec Lamp[F]	Turns the front recording lamp on/off.	
	On / Off		
	Rec Lamp[R]	Turns the rear recording lamp on/off.	
	On / Off		
	Rec Lamp Setting for the recording lamp	Rec Lamp[F]	Turns the front recording lamp on/off.
		Rec Lamp[R]	Turns the rear recording lamp on/off.
	Language Setting the language	Select	Sets the language to be displayed. SET: Execute this function.

System		
Menu items	Sub items and setting values	Contents
Clock Set Setting the built-in clock	Time Zone UTC -12:00 Kwajalein to UTC +14:00	Sets the time-zone difference from UTC in steps of 30 minutes.
	Date Mode YYMMDD / MMDDYY / DDDMMYY	Selects the display mode of the date. YYMMDD: In sequence of year, month, day MMDDYY: In sequence of month, day, year DDMMYY: In sequence of day, month, year
	12H/24H 12H / 24H	Selects the display mode of time. 12H: 12-hour mode 24H: 24-hour mode
	Date	Sets the current date. SET: Sets the date.
	Time	Sets the current time. SET: Sets the time.
	Country Setting the region	NTSC/PAL Area
Hours Meter Displaying the hours meter	Hours(System)	Displays the non-resettable accumulated time of use.
	Hours(Reset)	Displays the resettable accumulated time of use.
	Reset Execute / Cancel	Resets the "Hours(Reset)" value to 0. Execute: Execute resetting.
Basic Authentication Setting basic authentication of the network	User Name (admin)	Sets a desired user name (1 to 16 alphanumeric characters). SET: Sets the user name.
	Password (pxw-z100)	Sets the password (1 to 16 alphanumeric characters). SET: Execute this function.
Wi-Fi Setting for Wi-Fi connection and respective display items	Wi-Fi Enable / Disable	Selects whether to enable the Wi-Fi connection or not.
	SSID & Password	Displays the SSID and password.
	Wi-Fi Direct Connection Execute / Cancel	Starts processing the connection by Wi-Fi Direct. Execute: Executes this function.
	Client	Displays the connected client device (device name or Mac address).
	IP Address 10.0.0.1	Displays the IP address of the camcorder.
	Subnet Mask 255.255.0.0	Displays the subnet mask of the camcorder.
	MAC Address	Displays the MAC address of the Wi-Fi module of the camcorder.
	Regenerate Password Execute / Cancel	Regenerates the password. Execute: Executes this function.
	All Reset Resetting to the factory status	Reset Execute / Cancel
Version Showing the version of this camcorder	Number Vx.xx	Displays the current software version of the camcorder.
	Version Up Execute / Cancel	Upgrades the camcorder*. Execute: Executes. * Upgrade is the function for updating the software of the camcorder.

Thumbnail menu

Thumbnail

Menu items	Sub items and setting values	Contents
Display Clip Properties Displaying the detailed information screen of a clip		Opens the detailed information screen of the clip.
Delete Clip Deleting a clip	Execute / Cancel	Deletes a selected clip (one or more clips should be selected). Execute: Executes this function.
Delete All Clips Deleting all clips	Execute / Cancel	Deletes all clips. Execute: Executes this function.
Customize View Displaying the still image thumbnail screen	Thumbnail Caption Date Time / Time Code / Duration / Sequential Number	Changes the items that are displayed directly under thumbnails.

Connecting External Monitors and Recording Devices

To display recording/playback pictures on an external monitor, select the output signal and use an appropriate cable for the monitor to be connected.

An output signal from the camcorder can be recorded when a recording device is connected. The same status information and menus can be displayed on the external monitor as those on the viewfinder screen.

According to the signal fed to the monitor, set “Output Display” (page 44) in the Video menu to “On.”

SDI OUT connector (BNC type)

Set the on/off setting of the output, and output format in the Video menu (page 44).

Use a commercially available 75-ohm coaxial cable for connection.

To start synchronized recording on an external device

With SDI signal output selected, synchronized recording is possible by feeding a REC trigger signal to an external recording device connected via the SDI OUT connector. To enable synchronized recording, set “SDI/HDMI Rec Control” (page 48) in the Recording menu to “On.”

Notes

- When a connected external device does not correspond to a REC trigger signal, the device cannot be operated.

HDMI OUT connector (Type A connector)

Set the on/off setting of the output, and output format in the Video menu (page 44).

Use a supplied HDMI cable for connection.

When you use a commercially available HDMI cable, use a high speed HDMI cable.

VIDEO OUT connector (Pin connector)

Use the supplied A/V connecting cable for connection.

For details, see “Video formats and output signals” (page 61).

Operating Clips with a Computer

Connecting with a USB cable

To use an XQD card reader (sold separately)

When you connect the MRW-E80 XQD card reader (sold separately) using a USB cable, the memory card in the slot is acknowledged as an extended drive by the computer.

When two memory cards are mounted in this camcorder, they are acknowledged as two independent extended drives by the computer.

Notes

- The MRW-E80 does not work on the bus power from the computer. Supply the operating power independently.

To use mass storage mode of the camcorder

1 Set the power switch to ON to turn on the camcorder.

A message prompting you to confirm that you wish to enable the USB connection is displayed on the LCD/viewfinder screen.

Notes

- This message will not be displayed while another confirmation message or in-progress message (e.g., for formatting or restoring of an XQD memory card) is shown on the screen. It appears when formatting or restoration has completed. The message is also not displayed while the screen for the detailed information of a clip is shown on the screen. It appears when an operation on the screen for the detailed information of a clip is completed or you return to the thumbnail screen.

2 Select “Execute” by turning the SEL/SET dial.

3 With Windows, check that the memory card is displayed as a removable disk in My Computer.

With Macintosh, check that a “NO NAME” or “Untitled” folder was created on the desktop. (The Macintosh folder name can be changed.)

Notes

- The following operations must be avoided when the access lamp is lit in red.
 - Turning the power off or disconnecting the power cord (main lead)
 - Removing the XQD memory card
 - Disconnecting the USB cable
- When removing an XQD memory card from a Macintosh, do not select “Card Power Off” from the XQD memory card icon displayed on the menu bar.
- Operation is not guaranteed with all computers.

Using a nonlinear editing system

For a nonlinear editing system, an editing software that corresponds to the recording formats used with this camcorder (sold separately) is required.

Store the clips to be edited on the HDD of your computer in advance, using the dedicated application software.

Important Notes on Operation

Recording time of movies

Estimated duration of recording and playback

Recording time

Approximate time available when you use a fully charged battery pack.

(unit: minute)

	Continuous recording time		Typical recording time	
	4K	HD	4K	HD
LCD screen	160 (30P)	145 (60P)	75 (30P)	65 (60P)
	165 (25P)	155 (50P)	75 (25P)	70 (50P)
Viewfinder	165 (30P)	150 (60P)	80 (30P)	70 (60P)
	170 (25P)	160 (50P)	80 (25P)	75 (50P)

Notes

- Using ECM-XM1 (supplied)
- Typical recording time shows the time when you repeat recording start/stop, zooming, and so on.
- Times measured when using the camcorder at 25 °C (77 °F) (10 °C to 30 °C (50 °F to 86 °F) is recommended).
- The recording and playback time will be shorter when you use your camcorder in low temperatures.
- The recording and playback time will be shorter depending on the conditions under which you use your camcorder.

Playing time

Approximate time available when you use a fully charged battery pack.

(unit: minute)

	4K	HD
LCD screen	210 (30P)	210 (60P)
	220 (25P)	215 (50P)
Viewfinder	220 (30P)	220 (60P)
	230 (25P)	225 (50P)

Estimated recording time of movies

(unit: minute)

Format	Resolution	Frame rate	Bit-rate (approx.)	Recording time 32GB (approx.)	Recording time 64GB (approx.)
XAVC [4K] Intra 422 10bit	4096×2160 3840×2160	59.94P	600Mbps	5	10
		50P	500Mbps	7	15
		29.97P	300Mbps	10	20
		25P	250Mbps	10	25
		23.98P	240Mbps	10	30
XAVC [HD] Intra 422 10bit	1920×1080	59.94P	223Mbps	15	30
		50P	223Mbps	15	30
		29.97P	112Mbps	25	60
		25P	112Mbps	30	60
		23.98P	89Mbps	30	75

Notes

- Available recording time may vary depending on the recording conditions, subject conditions, etc.
-

- You can record movies to a maximum of 660 scenes in total.
- The maximum continuous recording time of movies is approximately 13 hours.
- Your camcorder uses the VBR (Variable Bit Rate) format to automatically adjust image quality to suit the recording scene. This technology causes fluctuations in the recording time of the media. Movies containing quickly moving and complex images are recorded at a higher bit-rate, and this reduces the overall recording time.

Using your camcorder abroad

Power supply

You can use your camcorder in any country/region using the AC Adaptor or Charger supplied with your camcorder within the AC 100 V to 240 V, 50 Hz/60 Hz range.

Viewing on TV

Before recording a movie with your camcorder for viewing on a TV, set “NTSC/PAL Area” in “Country” of System menu to the appropriate TV system for the country/region in which you intended to view the movie. The following shows which countries and regions require “NTSC Area” or “PAL Area” setting.

NTSC Area:

Bahama Islands, Bolivia, Canada, Central America, Chile, Colombia, Ecuador, Guyana, Jamaica, Japan, Korea, Mexico, Peru, Surinam, Taiwan, the Philippines, the U.S.A., Venezuela, etc.

PAL Area:

Argentina, Australia, Austria, Belgium, Brazil, Bulgaria, China, Czech Republic, Denmark, Finland, France, Germany, Guiana, Holland, Hong Kong, Hungary, Iran, Iraq, Italy, Kuwait, Malaysia, Monaco, New Zealand, Norway, Paraguay, Poland, Portugal, Russia, Singapore, Slovak Republic, Spain, Sweden, Switzerland, Thailand, Ukraine, United Kingdom, Uruguay, etc.

Simple setting of the clock by time difference

When you are abroad, set “Time Zone” of “Clock Set” in the System menu (*page 50*).

Use and Storage

Do not subject the unit to severe shock

The internal mechanism may be damaged or the body warped.

Do not cover the unit while operating

Putting a cloth, for example, over the unit can cause excessive internal heat build-up.

After use

Always set the power switch to OFF.

Before storing the unit for a long period

Remove the battery pack.

Do not leave the camcorder with the lenses facing the sun

Direct sunlight can enter through the lenses, be focused in the camcorder, and cause fire.

Shipping

- Remove the memory cards before transporting the unit.
- If sending the unit by truck, ship, air or other transportation service, pack it in the shipping carton of the unit.

Care of the unit

If the body of the unit is dirty, clean it with a soft, dry cloth. In extreme cases, use a cloth steeped in a little neutral detergent, then wipe dry. Do not use organic solvents such as alcohol or thinner, as these may cause discoloration or other damage to the finish of the unit.

About the “InfoLITHIUM” battery pack

Your camcorder operates only with an “InfoLITHIUM” L series battery pack of a large capacity, NP-F970 (supplied).

You cannot use NP-F570/F770 (sold separately).

“InfoLITHIUM” L series battery packs have the  mark.

What is an “InfoLITHIUM” battery pack?

An “InfoLITHIUM” battery pack is a lithium-ion battery pack that has functions for communicating information related to operating conditions between your camcorder, the supplied AC Adaptor or Charger.

To charge the battery pack

- Be sure to charge the battery pack before you start using your camcorder.







To use the battery pack effectively

- Battery pack performance decreases when the ambient temperature is 10 °C (50 °F) or below, and the length of time you can use the battery pack becomes shorter. In that case, do one of the following to use the battery pack for a longer time.
 - Put the battery pack in a pocket to warm it up, and install it in your camcorder right before you start taking shots.

- Be sure to set the POWER switch to OFF when not recording or playing back on your camcorder. The battery pack is also consumed when your camcorder is in recording standby or playback pause.
- Have spare battery packs ready for 2 or 3 times the expected recording time, and make trial recordings before making the actual recording.
- Do not expose the battery pack to water. The battery pack is not water resistant.

About the remaining battery indicator

- Check the level with the following indicators displayed on the LCD screen.

Battery remaining indicator	Detected voltage
	7.4 –
	7.2 – 7.3
	7.0 – 7.1
	6.8 – 6.9
	6.6 – 6.7
	– 6.5

- The displayed level may not be correct under certain circumstances.
- When the power goes off even though the remaining battery time indicator indicates that the battery pack has enough power to operate, charge the battery pack fully again. Remaining battery time will be indicated correctly. Note, however, that the battery indication will not be restored if it is used in high temperatures for a long time, or if left in a fully charged state, or when the battery pack is frequently used. Use the remaining battery time indication as a rough guide only.

About storage of the battery pack

- If the battery pack is not used for a long time, fully charge the battery pack and use it up on your camcorder once a year to maintain proper function. To store the battery pack, remove it from your camcorder and put it in a dry, cool place.
- To discharge the battery pack on your camcorder completely, leave your camcorder in recording standby until the power goes off (*page 12*).

About battery life

- Battery capacity decreases over time and through repeated use. If decreased usage time between charges becomes significant, it is probably time to replace it with a new one.
- Each battery's life is governed by storage, operating and environmental conditions.

About charging the battery pack

- Use the Charger (supplied) to charge the designated batteries only. If you charge other types of batteries, those batteries may leak, heat up, burst, or give an electric shock, resulting in burns or injury.
- Remove the charged battery from the Charger.
- The charge lamp of the supplied Charger flashes in 2 patterns as follows:
Fast-flashing... Turns on and off rapidly at about 0.15-second intervals.
Slow-flashing... Turns on and off alternately for about 1.5 seconds, and turns off completely for about 1.5 seconds. The lamp repeats this sequence.
- If the charge lamp is fast-flashing, remove the battery that is being charged, and then reattach the same battery again firmly. If the charge lamp continues fast-flashing, the cause could be that the battery is damaged, or the battery is not a designated type. Check the battery to confirm whether it is a designated type or not. If it is a designated type, remove the battery first, and then attach a brand-new battery or another known-to-be-good battery to see if the Charger is working correctly. If the Charger is working correctly, the cause could be that the battery is damaged.
- If the charge lamp is slow-flashing, the Charger is in standby mode and charging is suspended. When the ambient temperature is out of the appropriate temperature range for charging, the Charger suspends charging automatically and enters standby mode. When the ambient temperature returns to an appropriate temperature, the Charger restarts charging and the charge lamp lights up. We recommend charging the battery pack in an ambient temperature of from 10 °C to 30 °C (50 °F to 86 °F).

About handling of your camcorder

On use and care

- Do not use or store the camcorder and accessories in the following locations.
 - Anywhere extremely hot or cold. Never leave them exposed to temperatures above 60 °C (140 °F), such as under direct sunlight, near heaters or in a car parked in the sun. They may malfunction or become deformed.
 - Near strong magnetic fields or mechanical vibration. The camcorder may malfunction.
 - Near strong radio waves or radiation. The camcorder may not be able to record properly.
 - Near AM receivers and video equipment. Noise may occur.
 - On a sandy beach or anywhere dusty. If sand or dust gets in your camcorder, it may malfunction. Sometimes this malfunction cannot be repaired.
 - Near windows or outdoors, where the LCD screen, the viewfinder, or the lens may be exposed to direct sunlight. This damages the inside of the viewfinder or the LCD screen.
 - Anywhere very humid.
- Operate your camcorder on DC 7.2 V (battery pack) or DC 8.4 V (AC Adaptor).
- For DC or AC operation, use the accessories recommended in these operating instructions.
- Do not let your camcorder get wet, for example, from rain or sea water. If your camcorder gets wet, it may malfunction. Sometimes this malfunction cannot be repaired.
- If any solid object or liquid gets inside the casing, unplug your camcorder and have it checked by a Sony dealer before operating it any further.
- Avoid rough handling, disassembling, modifying, physical shock, or impact such as hammering, dropping or stepping on the product. Be particularly careful of the lens.
- Do not use a deformed or damaged battery pack.
- Keep the POWER switch setting to OFF when you are not using your camcorder.
- Do not wrap your camcorder with a towel, for example, and operate it. Doing so might cause heat to build up inside.
- When disconnecting the power cord (mains lead), pull it by the plug and not the lead.

- Do not damage the power cord (mains lead) such as by placing anything heavy on it.
- Keep metal contacts clean.
- Keep the Wireless Remote Commander and button-type battery out of children's reach. If the battery is accidentally swallowed, consult a doctor immediately.
- If the battery electrolytic liquid has leaked,
 - consult your local authorized Sony service facility.
 - wash off any liquid that may have contacted your skin.
 - if any liquid gets in your eyes, wash with plenty of water and consult a doctor.

When not using your camcorder for a long time

- Turn on the camcorder and record and play back images about once a month to keep it in an optimum state for a long time.
- Use up the battery pack completely before storing it.

Moisture condensation

If your camcorder is brought directly from a cold place to a warm place, moisture may condense inside your camcorder and cause a malfunction of your camcorder.

If moisture condensation has occurred

Leave your camcorder for about 1 hour without turning it on.

Note on moisture condensation

Moisture may condense when you bring your camcorder from a cold place into a warm place (or vice versa) or when you use your camcorder in a humid place as shown below.

- When you bring your camcorder from a ski slope into a place warmed up by a heating device.
- When you bring your camcorder from an air conditioned car or room into a hot place outside.
- When you use your camcorder after a squall or a shower.
- When you use your camcorder in a hot and humid place.

How to avoid moisture condensation

When you bring your camcorder from a cold place into a warm place, put your camcorder in a plastic bag and seal it tightly. Remove the bag when the air temperature inside the plastic bag has reached the ambient temperature (after about 1 hour).

LCD screen

- Do not exert excessive pressure on the LCD screen, as it may cause damage.
- If your camcorder is used in a cold place, a residual image may appear on the LCD screen. This is not a malfunction.
- While using your camcorder, the back of the LCD screen may heat up. This is not a malfunction.

To clean the LCD screen

The surface of the LCD screen is coated. If you scratch the surface, the coating may be come off. Mind the following points when cleaning and handling it.

- If hand grease or hand cream remains on the screen, the coating comes off more easily. Wipe it early.
- The coating may be scratched if you wipe the screen with a tissue, etc.
- Remove the dust or sand with a blower, etc. before wiping the dirt.
- Use a soft cloth (a cloth for glasses, etc.) gently to clean the dirt.

On handling the casing

- If the casing is soiled, clean the camcorder body with a soft cloth lightly moistened with water, and then wipe the casing with a dry soft cloth.
- Avoid the following to avoid damage to the finish.
 - Using chemicals such as thinner, benzine, alcohol, chemical cloths, repellent, insecticide and sunscreen.
 - Handling with above substances on your hands.
 - Leaving the casing in contact with rubber or vinyl objects for a long period of time.

About care and storage of the lens

- Wipe the surface of the lens clean with a soft cloth in the following instances:
 - When there are fingerprints on the lens surface.
 - In hot or humid locations
 - When the lens is exposed to salty air such as at the seaside.
- Store in a well-ventilated location subject to little dirt or dust.
- To prevent mold, periodically clean the lens as described above.

On charging the pre-installed rechargeable battery

Your camcorder has a pre-installed rechargeable battery to retain the date, time, and other settings even when the POWER switch is set to OFF. The pre-installed rechargeable battery is always charged while your camcorder is connected to the wall outlet (wall socket) via the AC Adaptor or while the battery pack is attached. The rechargeable battery will be fully discharged in about **3 months** if you do not use your camcorder at all without the AC Adaptor connected or the battery pack attached. Use your camcorder after charging the pre-installed rechargeable battery.

However, even if the pre-installed rechargeable battery is not charged, the camcorder operation will not be affected as long as you are not recording the date.

Removing dust from inside the viewfinder

1 Remove the eye piece of the viewfinder.

Slide down the viewfinder release lever and hold it at the position (①), then lift the eye piece of the viewfinder as indicated with the arrow in the illustration (②).

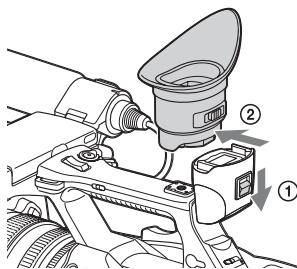

2 Remove dust inside the eye piece and viewfinder with a blower.

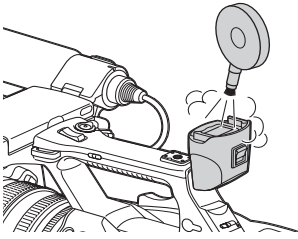

To prevent electromagnetic interference from portable telephones, wireless devices, etc.

The use of portable telephones, wireless devices, etc., near this unit can result in malfunctions and interference with audio and video signals. It is recommended that such equipment near this unit is powered off.

About the LCD screen

- Do not leave the LCD screen facing direct sunlight, as this may damage the LCD screen.
- Do not press/swipe the LCD screen forcefully, or leave objects on the LCD screen, as it may cause a malfunction, such as picture irregularity, etc.
- The LCD screen may become warm in use. This is not a malfunction.

About the stuck pixels

The LCD screen fitted to this unit is manufactured with high precision technology, giving a functioning pixel ratio of at least 99.99%. Thus a very small proportion of pixels may be “stuck”, either always off (black), always on (red, green, or blue), or flashing. In addition, over a long period of use, because of the physical characteristics of the liquid crystal display, such “stuck” pixels may appear spontaneously. These problems are not a malfunction, and will not be recorded on recording media.

Note on the display

- Pictures on the LCD screen and viewfinder screen may be distorted by the following operations:
 - Changing the video format
 - Starting playback from the Thumbnail screen
 - Reversing the LCD screen
- When you change the eye direction in the viewfinder, you may see primary colors red, green, and blue, but this is not a defect of the camcorder. These primary colors are not recorded on any recording media.

Fragmentation

If pictures cannot be recorded/reproduced properly, try formatting the recording medium. While repeating picture recording/playback with a certain recording medium for an extended period, files in the medium may be fragmented, disabling proper recording/storage. In such a case, make a backup of clips in the medium then perform formatting of the medium using “Format Media” (page 48) in the Media menu.

Formats and Limitations of Outputs

Video formats and output signals

Output formats for the SDI OUT connector

Region setting	Recording format setting	SDI output setting	Output signal/ Conversion method
“NTSC/PAL Area” in “Country” of System menu	“Video Format” in “Rec Format” of System menu	“SDI” in “Output Format” of Video menu	Output signal
NTSC Area	4096×2160 59.94P	2048×1080P	2048×1080 59.94P
		1920×1080P	1920×1080 59.94P
		1920×1080i	1920×1080 59.94i
	4096×2160 29.97P	2048×1080P	2048×1080 29.97P
		1920×1080P	1920×1080 29.97PsF
		1920×1080i	1920×1080 29.97PsF
	4096×2160 23.98P	2048×1080P	2048×1080 23.98P
		1920×1080P	1920×1080 23.98P
		1920×1080i	1920×1080 23.98PsF
	3840×2160 59.94P	1920×1080P	1920×1080 59.94P
		1920×1080i	1920×1080 59.94i
	3840×2160 29.97P	1920×1080P	1920×1080 29.97PsF
		1920×1080i	1920×1080 29.97PsF
	3840×2160 23.98P	1920×1080P	1920×1080 23.98P
		1920×1080i	1920×1080 23.98PsF
	1920×1080 59.94P	1920×1080P	1920×1080 59.94P
		1920×1080i	1920×1080 59.94i
	1920×1080 29.97P	1920×1080P	1920×1080 29.97PsF
		1920×1080i	1920×1080 29.97PsF
	1920×1080 23.98P	1920×1080P	1920×1080 23.98P
1920×1080i		1920×1080 23.98PsF	
PAL Area	4096×2160 50P	2048×1080P	2048×1080 50P
		1920×1080P	1920×1080 50P
		1920×1080i	1920×1080 50i
	4096×2160 25P	2048×1080P	2048×1080 25P
		1920×1080P	1920×1080 25PsF
		1920×1080i	1920×1080 25PsF
	3840×2160 50P	1920×1080P	1920×1080 50P
		1920×1080i	1920×1080 50i
	3840×2160 25P	1920×1080P	1920×1080 25PsF
		1920×1080i	1920×1080 25PsF
	1920×1080 50P	1920×1080P	1920×1080 50P
		1920×1080i	1920×1080 50i
1920×1080 25P	1920×1080P	1920×1080 25PsF	
	1920×1080i	1920×1080 25PsF	

Notes

- If you set “HDMI” in “Output Format” of the Video menu to “4096x2160P” or “3840x2160P,” signals cannot be output from the SDI OUT connector.

Output formats from the HDMI OUT connector

Region setting	Recording format setting	HDMI output setting	Output signal/ Conversion method
“NTSC/PAL Area” in “Country” of System menu	“Video Format” in “Rec Format” of System menu	“HDMI” in “Output Format” of Video menu	Output signal
NTSC Area	4096x2160 59.94P	4096x2160P	4096x2160 59.94P*
		3840x2160P	3840x2160 59.94P*
		1920x1080P	1920x1080 59.94P
		1920x1080i	1920x1080 59.94i
		720x480P	720x480 59.94P
	3840x2160 59.94P	3840x2160P	3840x2160 29.97P
		1920x1080P	1920x1080 59.94i
		1920x1080i	1920x1080 59.94i
		720x480P	720x480 59.94P
	4096x2160 23.98P	4096x2160P	4096x2160 23.98P
		3840x2160P	3840x2160 23.98P
		1920x1080P	1920x1080 23.98P
		1920x1080i	1920x1080 59.94i
		720x480P	720x480 59.94P
	3840x2160 59.94P	3840x2160P	3840x2160 59.94P*
		1920x1080P	1920x1080 59.94P
		1920x1080i	1920x1080 59.94i
		720x480P	720x480 59.94P
	3840x2160 29.97P	3840x2160P	3840x2160 29.97P
		1920x1080P	1920x1080 59.94i
		1920x1080i	1920x1080 59.94i
		720x480P	720x480 59.94P
	3840x2160 23.98P	3840x2160P	3840x2160 23.98P
		1920x1080P	1920x1080 23.98P
		1920x1080i	1920x1080 59.94i
		720x480P	720x480 59.94P
	1920x1080 59.94P	1920x1080P	1920x1080 59.94P
		1920x1080i	1920x1080 59.94i
720x480P		720x480 59.94P	
1920x1080 29.97P	1920x1080P	1920x1080 59.94i	
	1920x1080i	1920x1080 59.94i	
	720x480P	720x480 59.94P	
1920x1080 23.98P	1920x1080P	1920x1080 23.98P	
	1920x1080i	1920x1080 59.94i	
	720x480P	720x480 59.94P	

Region setting	Recording format setting	HDMI output setting	Output signal/ Conversion method
“NTSC/PAL Area” in “Country” of System menu	“Video Format” in “Rec Format” of System menu	“HDMI” in “Output Format” of Video menu	Output signal
PAL Area	4096×2160 50P	4096×2160P	4096×2160 50P*
		3840×2160P	3840×2160 50P*
		1920×1080P	1920×1080 50P
		1920×1080i	1920×1080 50i
		720×576P	720×576 50P
	3840×2160 25P	3840×2160P	3840×2160 25P
		1920×1080P	1920×1080 50i
		1920×1080i	1920×1080 50i
		720×576P	720×576 50P
	3840×2160 50P	3840×2160P	3840×2160 50P*
		1920×1080P	1920×1080 50P
		1920×1080i	1920×1080 50i
		720×576P	720×576 50P
	3840×2160 25P	3840×2160P	3840×2160 25P
		1920×1080P	1920×1080 50i
		1920×1080i	1920×1080 50i
		720×576P	720×576 50P
	1920×1080 50P	1920×1080P	1920×1080 50P
		1920×1080i	1920×1080 50i
		720×576P	720×576 50P
	1920×1080 25P	1920×1080P	1920×1080 50i
		1920×1080i	1920×1080 50i
		720×576P	720×576 50P

* Compatible with the Sony transmission system.

You can connect the camcorder to a Sony 4K television, or a 4K monitor.

Picture resolution is Y:Cb:Cr=4:2:0.

Output formats from the VIDEO OUT connector

Signals to the VIDEO OUT connector cannot be output when “HDMI” in “Output Format” of the Video menu is set to “3840×2160P.”

Video output signal

Setting for the region where the camcorder is used	VIDEO output
“NTSC/PAL Area” in “Country” of System menu	
NTSC Area	720×486 59.94i
PAL Area	720×576 50i

Notes

- If you set both “HDMI” and “SDI” in “Output On/Off” of the Video menu to “On,” signals cannot be output from the VIDEO OUT connector.
- If you set “HDMI” in “Output Format” of the Video menu to “4096×2160P” or “3840×2160P,” signals cannot be output from the VIDEO OUT connector.
- If the recording format of a playback clip is smaller than that set in “SDI” or “HDMI” in “Output Format” of the Video menu, video signals are not output from the SDI or HDMI connector respectively.

Error/Warning Indications

The camcorder informs you of situations where warning, caution, or an operation check is required, through messages on the LCD/viewfinder screen, the recording lamp, and a buzzer. The buzzer is output to the headphones connected via the headphone connector.

Error indications

The camcorder stops operation after the following indications.

Error indication on LCD/viewfinder	Buzzer	Recording lamp	Cause and measures
C:04:□□			The battery pack is not an "InfoLITHIUM" battery pack. Use an "InfoLITHIUM" battery pack (<i>page 56</i>).
C:06:□□			The battery pack temperature is high. Change the battery pack or place it in a cool place.
C:32:□□			Remove the power source. Reconnect it and operate your camcorder again.
E:20:□□/E:40:□□/ E:41:□□/E:50:□□/ E:51:□□/E:61:□□/ E:62:□□/E:92:□□/ E:94:□□/E:95:□□			Perform the following steps. 1 Check the list, and inspect your camcorder. 2 Disconnect the power source, attach the power source again after about 1 minute, and turn the camcorder on. 3 Contact your Sony dealer or local authorized Sony service facility.

Warning indications

When one of the following indications is generated, follow the message to resolve the problem.

Warning indication on LCD/viewfinder	Buzzer	Recording lamp	Cause and measures
Media Near Full	Intermittent	Flashing	Free space on the XQD memory card has become insufficient. Replace it with another at the earliest opportunity.
Media Full	Continuous	Rapidly flashing	No space is left on the XQD memory card. Recording, clip copying and clip division cannot be performed. Replace it with another.
Battery Near End	Intermittent	Flashing	The battery power will be discharged soon. Charge the battery pack at the earliest opportunity.
Battery End	Continuous	Rapidly flashing	The battery pack is discharged. Recording cannot be performed. Stop operation and change the battery pack.
Battery Temperature High Turn Power Off			The temperature of the battery pack has risen above a safe operation limit. The camcorder turns off automatically.
Temperature High	Intermittent	Flashing	The internal temperature has risen above a safe operation limit. Suspend operation, turn off the power, and wait until the temperature falls.
Battery Error Please Change Battery			An error was detected with the battery pack. Replace the battery pack with a normal one.

Warning indication on LCD/viewfinder	Buzzer	Recording lamp	Cause and measures
Unknown Media(A)* Please Change			A partitioned memory card or one that contains recorded clips exceeding the number permitted with this camcorder is loaded. This card cannot be used with this camcorder. Remove it and load a compatible card.
Media Error Media(A) Needs to be Restored*			An error occurred with the memory card. The card requires restoration. Remove the card, load it again, and restore it.
Media Error Cannot Record to Media(A)*			Recording cannot be done, because the memory card is defective. Because playback may be possible, it is recommended to replace it with another card after copying the clips, as required.
Media Error Cannot Use Media(A)*			Neither recording nor playback can be done, because the memory card is defective. It cannot be operated with this camcorder. Replace it with another card.
Will Switch Slots Soon			This is an advanced notice that the camcorder will switch from the current memory card to the other memory card for continuous recording.
Cannot Use Media(A)* Unsupported File System			A card of a different file system or an unformatted card was inserted. It cannot be used with this camcorder. Replace it or format it with this camcorder.
Media Error Playback Halted			An error occurred in reading data from the memory card, and playback cannot be continued. If this frequently occurs, change the memory card after copying the clips, as required.
Media(A) Error*			Recording cannot be done, because an error occurred with the memory card. If this frequently occurs, change the memory card.
Media Reached Rewriting Limit Change Media(A)*			The memory card comes to the end of its service life. Make a backup copy and replace the card with another one as soon as possible. Recording/playback may not be performed properly if you continue to use the card. <i>For details, refer to the operating instructions of the memory card.</i>
Cannot Use Media(A)* Unsupported File System			A memory card with different file system is inserted. Replace the card, format it with the camcorder.
Battery Temperature High	Intermittent	Flashing	The temperature of the battery pack is rising. Turn off the power and replace the battery pack with another one or wait until the temperature falls.

* “Media(B)” for the card in slot B.

Licenses

On accessing software to which the GPL/LGPL applies

This product uses software to which the GPL/LGPL applies. This informs you that you have a right to have access to, modify, and redistribute source code for these software programs under the conditions of the GPL/LGPL.

The source code is provided on the internet. Use the following URL and follow the download instructions.

<http://www.sony.net/Products/Linux/common/search.html>

We would prefer that you do not contact us about the contents of the source code.

For the content of these licenses, see "License1.pdf" in the "License" folder of the supplied CD-ROM.

Adobe Reader must be installed on your computer to view PDF files.

If Adobe Reader is not installed on your computer, you can download it by accessing the following URL.

<http://get.adobe.com/reader/>

Open software licenses

On the basis of license contracts between Sony and the software copyright holders, this product uses open software.

To meet the requirements of the software copyright holders, Sony is obligated to inform you of the content of these licenses.

For the content of these licenses, see "License1.pdf" in the "License" folder of the supplied CD-ROM.

Specifications

System

Video signal

4K image quality (3840×2160/4096×2160):
UHDTV

HD image quality: HDTV

Video recording system

4K image quality (3840×2160/4096×2160):
MXF AVC/H.264 XAVC ver.1.0 compatible
HD image quality: MXF AVC/H.264 XAVC
ver.1.0 compatible

Audio recording system

Linear PCM 8ch (2ch recording/playback)
48kHz 24bit

Recording media

XQD memory card

Image device

7.82 mm (1/2.3 type) CMOS sensor
Gross: Approx. 18 900 000 pixels
Effective (movie, 16:9): Approx. 8 300 000
pixels
Effective (movie, 17:9): Approx. 8 800 000
pixels

Lens

G Lens
20 × (Optical)
Focal length
f=4.1 mm - 82.0 mm (3/16 in. - 3 1/4 in.)
When converted to a 35 mm still camera
31.5 mm - 630 mm (1 1/4 in. - 24 7/8 in.)
(16:9)
30.0 mm - 600 mm (1 3/16 in. - 23 5/8 in.)
(17:9)
F1.6 - F3.4
Filter diameter: 72 mm (2 7/8 in.)

Color temperature

"Indoor" (3 200K)
"Outdoor" (5 600K)
"Color Temp." (2 300K - 15 000K)

Minimum illumination

60P (NTSC Area):
4 lx (lux) (Fixed Shutter Speed 1/30, manual
gain (27 dB), auto iris (F1.6))
50P (PAL Area):
3 lx (lux) (Fixed Shutter Speed 1/25, manual
gain (27 dB), auto iris (F1.6))

Input/Output connectors**VIDEO OUT connector**

Pin connector
1 V_{p-p}, 75 Ω (ohms) unbalanced, sync negative

AUDIO OUT connectors

Pin connectors
-10 dBu (at load impedance 47 kΩ (kilohms)), Output impedance with less than 2.2 kΩ (kilohms)
(0 dBu = 0.775 V_{rms})

HDMI OUT connector

HDMI connector (Type A)

SDI OUT connector

BNC connector

🎧 (headphones) connector

Stereo-minijack (Ø 3.5 mm)

INPUT1/INPUT2 connectors

XLR 3-pin, female,
MIC: -50 dBu: 3 kΩ (kilohms)
LINE: +4 dBu: 10 kΩ (kilohms)
(0 dBu = 0.775 V_{rms})

USB connector

Mass-storage: mini-B
Host: Type A

Remote connector

Stereo mini-minijack (Ø 2.5 mm)

TC LINK connector

Pin connector

LCD screen**Picture**

8.8 cm (3.5 type, aspect ratio 16:9)

Total dot number

1 229 000 (854 × 480 × 3 [RGB])

Viewfinder**Picture**

0.45 type, aspect ratio 16:9

Total dot number

Approx. 1 226 880

General**Power requirements**

DC 7.2 V (battery pack)
DC 12 V 2.5 A (AC Adaptor)

Average power consumption

During camera recording using the microphone (ECM-XM1) and LCD with normal brightness

NTSC Area:

4K: 15.2 W (29.97P, 300Mbps)
HD: 16.7 W (59.94P, 223Mbps)

PAL Area:

4K: 14.5 W (25P, 250Mbps)
HD: 15.9 W (50P, 223Mbps)

Operating temperature

0 °C to 40 °C (32 °F to 104 °F)

Storage temperature

-20 °C to +60 °C (-4 °F to +140 °F)

Dimensions (approx.)

Camcorder body only (including the projecting parts):
189 mm × 193 mm × 362 mm
(7 1/2 in. × 7 5/8 in. × 14 3/8 in.) (w/h/d)
When recording (including the projecting parts):
189 mm × 193 mm × 449 mm
(7 1/2 in. × 7 5/8 in. × 17 3/4 in.) (w/h/d)
(With the accessories (battery pack (NP-F970), microphone (ECM-XM1), accessory shoe kit, large eyecup) attached.)

Mass (approx.)

Camcorder body only:
2 460 g (87 oz)
When recording:
2 910 g (103 oz) (With the accessories (battery pack (NP-F970), microphone (ECM-XM1), accessory shoe kit, large eyecup) attached.)

AC Adaptor AC-NB12A**Power requirements**

AC 100 V - 240 V, 50 Hz/60 Hz

Current consumption

0.65 A - 0.35 A

Power consumption

30 W

Output voltage

DC 12 V*

Operating temperature

0 °C to 45 °C (32 °F to 113 °F)

Storage temperature

-20 °C to +60 °C (-4 °F to +140 °F)

Dimensions (approx.)

49.5 mm × 28 mm × 99.5 mm
(1 31/32 in. × 1 1/8 in. × 3 15/16 in.) (w/h/d)
excluding the projecting parts

Mass (approx.)

200 g (7.1 oz) excluding the power cord (mains lead)

* See the label on the AC Adaptor for other specifications.

Charger AC-VL1

Power requirements

AC 100 V - 240 V, 50 Hz/60 Hz

Current consumption

0.35 A - 0.18 A

Power consumption

22 W

Output voltage

DC 8.4 V*

Operating temperature

0 °C to 40 °C (32 °F to 104 °F)

Storage temperature

-20 °C to +60 °C (-4 °F to +140 °F)

Dimensions (approx.)

136 mm × 51 mm × 90 mm
(5 3/8 in. × 2 1/8 in. × 3 5/8 in.) (w/h/d)
excluding the projecting parts

Mass (approx.)

270 g (9.6 oz) excluding the power cord
(mains lead)

* See the label on the Charger for other specifications.

Rechargeable battery pack NP-F970

Maximum output voltage

DC 8.4 V

Output voltage

DC 7.2 V

Maximum charge voltage

DC 8.4 V

Maximum charge current

3.0 A

Capacity

Typical: 47.5 Wh (6 600 mAh)
Minimum: 45 Wh (6 300 mAh)

Type

Li-ion

Design and specifications are subject to change without notice.

- Manufactured under license from Dolby Laboratories.

Package configuration

Charger (1) (AC-VL1)

Rechargeable battery pack NP-F970 (1)

AC Adaptor (1) (AC-NB12A)

Power cord (mains lead) (2)

A/V connecting cable (1)

HDMI cable (1)

USB cable (1)

Lens hood (1)

Large eyecup (1)

Accessory shoe kit (accessory shoe (1), accessory shoe plate (1), screws (4))

Wind screen (1)

Microphone (1) (ECM-XM1)

USB wireless LAN module IFU-WLM3 (1)

CD-ROM “Manuals for Digital 4K Video

Camera Recorder” (1)

Operating Guide (2)

Software Downloads

When the unit is used with a PC connection, download device drivers, plug-ins, and application software, where applicable, from the Sony Professional products web site.

Sony Professional products web site homepage:

U.S.A. <http://pro.sony.com>

Canada <http://www.sonybiz.ca>

Latin America <http://sonypro-latin.com>

Europe, Middle East and Africa
<http://www.pro.sony.eu>

Japan <http://www.sonybsc.com>

Asia Pacific <http://pro.sony-asia.com>

Korea <http://bp.sony.co.kr>

China <http://pro.sony.com.cn>

Although the data regarding recorded materials are stored over multiple files and folders, you can easily handle the clips without considering its data and directory structure, by using the dedicated application software.

Notes

- If you perform operations, such as copy, on clips on the XQD memory card by using the Explorer (Windows) or Finder (Macintosh), the subsidiary data contained by the clips may not be maintained.

Design and specifications are subject to change without notice.

On trademarks

- “XDCAM” is a trademark of Sony Corporation.
- “XAVC” and **XAVC** are trademarks of Sony Corporation.
- XQD, and **XQD** are trademarks of Sony Corporation.
- “InfoLITHIUM” is a trademark of Sony Corporation.

- Microsoft, Windows, Windows Vista, and Windows Media are trademarks or registered trademarks of U.S. Microsoft Corporation in the U.S. and other countries.
- Mac and Mac OS are registered trademarks of Apple Inc. in the U.S. and other countries.
- HDMI, HDMI logo, and High-Definition Multimedia Interface are registered trademarks of HDMI Licensing LLC in the United States and other countries.
- Intel, Intel Core, and Pentium are trademarks or registered trademarks of Intel Corporation or its subsidiaries in the United States and other countries.
- Adobe, the Adobe logo, and Adobe Acrobat are either registered trademarks or trademarks of Adobe Systems Incorporated in the United States and/or other countries.

All other product names mentioned herein may be the trademarks or registered trademarks of their respective companies. Furthermore, ™ and “®” are not mentioned in each case in this manual.

Index

A

AC Adaptor 15
Accessory shoe 5
Accessory shoe mount 5
Accessory shoe plate 5
All File 48
All Reset 50
Assignable Button 33, 49
Audio 27
Audio Input 43
Audio menu 43
Audio Output 43
Auto Exposure 40
AUTO/MANUAL switch 28

B

Basic Authentication 50
Black 41

C

Camera menu 40
Charging time 15
Clip 27, 36, 53
Clip name 27
Clock 16
Clock Set 50
Color Bars 40
Country 50
Cueing up 27
Customize View 51

D

Delete All Clips 51
Delete Clip 51
Detail 42
Display Clip Properties 37
Display On/Off 46

E

Error Indications 64
Expanded focus 26
External Monitor 52

F

File menu 48
Flicker Reduce 40
Focus 26, 40
Focus ring 26
FOCUS switch 26
Format 19
Format Media 48

G

Gain 28, 40
GAIN button 28
Gain switch 28
Gamma 42

H

Handle Zoom 41
Handle zoom 25
Handle zoom lever 25
Handle zoom switch 25
HDMI OUT connector 52, 62
Headphones connector 8
Hook for shoulder strap 8
Hours Meter 50

I

Indoor 30
“InfoLITHIUM” battery pack 56
INPUT1 connector 16
IRIS button 28
Iris ring 28

K

Knee 42

L

Language 49
LCD screen 12, 17
LCD Setting 44
LCD/VF Menu 44
Lens 59
Lens cover lever 17
Lens hood with lens cover 17

M

Marker 45
Matrix 43

Media Full 20
Media menu 48
Media Near Full 20
MENU button 39
MIC+48V 31
Moisture condensation 58
MRW-E80 53

N

ND filter 29
Nonlinear editing 53

O

Offset White 41
One push button 30
OPTION button 36
Outdoor 30
Output Display 44
Output Format 44
Output signal 61

P

Paint menu 41
Peaking 44
Power cord (mains lead) 14
Power zoom lever 25
Pre-installed rechargeable battery 59
PUSH (lens hood release) button 17
PUSH AUTO button 26
Push auto focus 26

R

Rec Format 49
Rec Lamp 49
Record button 25
Recording menu 47

S

S&Q Motion 47
SDI OUT connector 52, 61
SDI/HDMI Rec Control 48
SEL/SET dial 39
Setup menu 39, 40
Shoulder strap 8
Shutter speed 29
SHUTTER SPEED button 29
Skin Detail 42
Slow & Quick Motion 33

Speed Zoom 41
SteadyShot 40
System menu 49

T

TC/UB menu 47
Telephoto 25
Thumbnail menu 36
Thumbnail screen 35
Time and date 16
Time Data 32
Time Zone 16
Timecode 32, 47

U

USB cable 53
USB wireless LAN module 20
Using your camcorder abroad 56
UTC 16

V

Version 50
VF Setting 44
Video format 61
Video menu 44
VIDEO OUT connector 52, 63
Viewfinder 12, 18
Viewfinder lens adjustment lever 18
Viewfinder release lever 59

W

Wall outlet (wall socket) 15
Warning Indications 64
White 41
White balance 29
White balance memory switch 30
WHT BAL button 29
Wide angle 25
Wi-Fi 50
Wi-Fi remote commander 21

X

XQD Memory Cards 18

Z

Zebra 45
Zoom 25
Zoom ring 26

<http://www.sony.net/>

Printed in China



4484009110