

# Instruction manual

PILOTFLY **C45**

Handheld 3-Axes Stabilizer for Premium Compact Cameras



Pilotfly Technology Co. LTD. ■ Jiafeng S. Rd. No.118,2F-2 ■ Zhubei City, Hsinchu County 30271 ■ Taiwan  
Pilotfly GmbH ■ Wendelsteinstr.12 ■ 86163 Augsburg ■ Deutschland

# Imprint

Version IM\_100.CCF.20170512-EN C45

English, 1<sup>st</sup> Edition, 05.2017



© Pilotfly

## Copyright

This document is protected by copyright. All rights, including those of the whole or partial photo-mechanical reproduction, duplication and spreading (e. g., by means of data processing, to data carriers and data network works) as well as content and technical changes, are left in the course of constant product improvements.

## Dear customer,

We thank you for your confidence and wish you a lot of joy and success with your new Pilotfly product. You have decided in favor of a high-quality product with that. The C45 is a revolutionary and genius gimbal. The Pilotfly C45 is a breakthrough on gimbal technology and the worlds first compact gimbal with direct view to the camera display. The C45 is a gimbal for premium compact cameras like the Sony RX100V, Panasonic LX10, LX100 or similar. Compact, powerful and extraordinary in the design. It is built on groundbreaking ideas.

Even if you are familiar with handling electronic equipments, please read the instruction manual, because it is an important component of this product. It contains important notes for the safety, the use and the disposal. Familiarize yourself with all hints to the use and the safety items before you use the product. Follow the notes and tips, so that you can use your new product optimally. Only use the product as described and for the indicated fields of application.

### IMPORTANT

AFTER YOU HAVE READ THE INSTRUCTION MANUAL, KEEP IT TOGETHER WITH THE PRODUCT FOR A LATER LOOKING UP. IN CASE YOU GIVE THE PRODUCT TO ANY THIRD PARTY, HAND OVER IT TOGETHER WITH ALL DOCUMENTS!

Nevertheless, if you should have problems with your product, please address your enquiry to [pilotflyteam@gmail.com](mailto:pilotflyteam@gmail.com) (Taiwan) or [info@pilotfly.de](mailto:info@pilotfly.de) (Germany). We help you along willingly promptly and give you information about the next steps.

#### Service Adresse Taiwan

Pilotfly Technology Co. LTD.  
Jiafeng South Rd. No.118, 2F-2  
Zhubei City, Hsinchu County 30271  
Taiwan

Email: [yanherlin@gmail.com](mailto:yanherlin@gmail.com)

#### Service Address Germany

Pilotfly GmbH  
Wendelsteinstr.12  
86163 Augsburg  
Deutschland

Email: [marcus.oswald@pilotfly.de](mailto:marcus.oswald@pilotfly.de)

## Trademark Proof

© Bluetooth SIG, Inc. Bluetooth SIG, Inc. All rights reserved. Bluetooth ® is a registered trademark of Bluetooth SIG, Inc. (Special Interest Group), USA.

© Google Inc. All rights reserved. The Google logo, Google, Android™ and Google Play are registered brands of Google Inc.

© Microsoft Corporation all rights reserved. Microsoft and Windows are registered trademarks of Microsoft Corporation in the United States and/or other countries.

© Apple Computer Inc. All rights reserved. Macintosh and OSs are registered trademarks of Apple Computer Inc. in the United States and/or other countries.

© Linux Torvalds all rights reserved. Linux is a registered trademark of Linus Torvalds.

All other products and brand names which are mentioned in this manual or in the other documentations to your Pilotfly product are trademarks or registered trademarks of the respective entitled persons.

# Product Overview

## Components

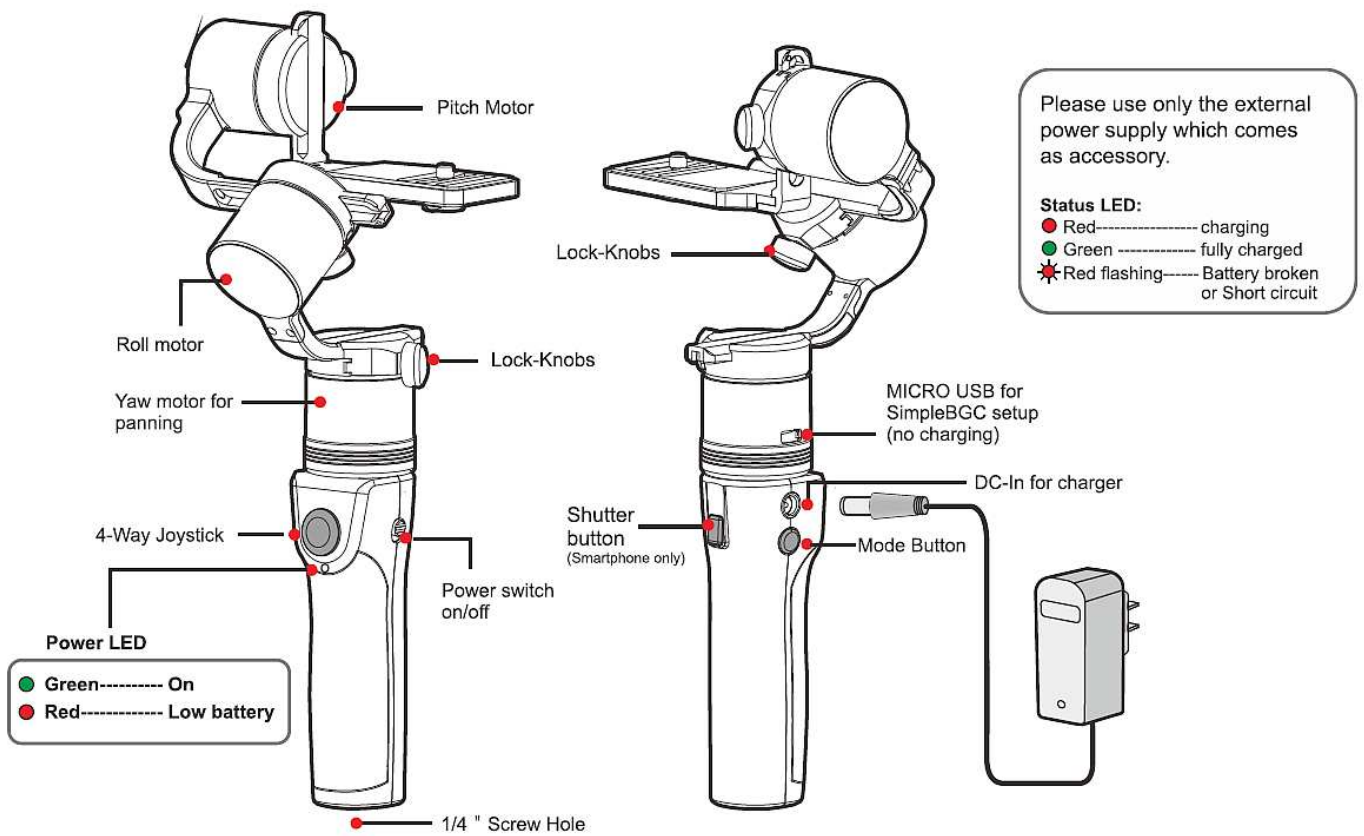

# Product Overview

## Function keys and LED displays

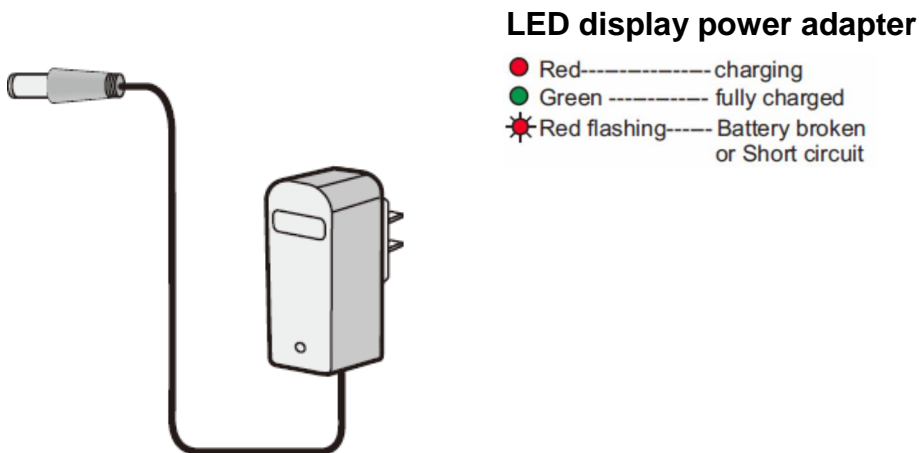
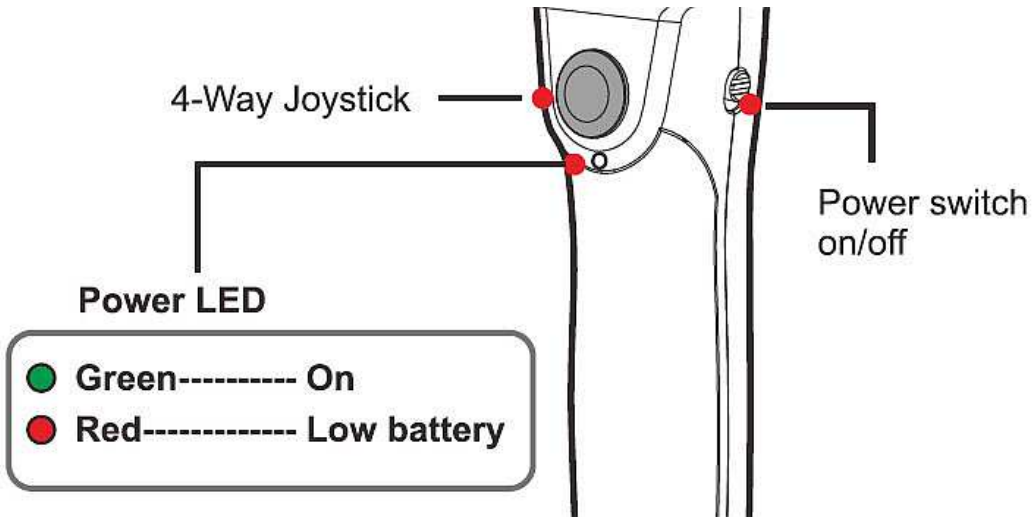

# Product Overview

---

## “Mode” button

The respective operating mode of your Pilotfly Gimbal can be set using the mode button. The mode button can be assigned different profiles using the SimpleBGC software GUI.

A profile is respectively a set of predefined settings such as, for example, different provisions for the following mode, the rotation speed of the individual axes, the initial alignment of the axes, time lapse settings, axis acceleration, control parameters tuned to your camera weight for optimal vibration reduction, parameters for smooth operation, etc.). You can optimize these settings according to your own preferences using the SimpleBGC 32 Bit software GUI ► 5. *Software use for PC/MAC* or also using the applicable SimpleBGC Apps for Android or iOS.

In the table you can see the pre-set assignment and a description of the settings stored as profile respectively:

Key sequence	Function		Description
1 x tap	Follow mode	Follow mode	<b>Profile 1</b> - Camera follows the movements.
2 x tap	Lock mode of pitch & roll axis	Lock mode	<b>Profile 2</b> - Camera remains in the horizon and only yaw follows the target.
3 x tap	Lock mode of all 3 axes	Head mode	<b>Profile 3</b> - All three axes are locked. Camera is kept in the adjusted position.
4 x tap	Rotates yaw axis 180°	Selfie mode	<b>Profile 4</b> – Rotates on Yaw-axis 180 degrees, for <i>selfie</i> recording.
5 x tap	Starting point „zero position“	Home position	<b>Home Position</b> - Camera returns to "zero position" into the starting point.
Press and hold 3 seconds	Activates the Gyro-calibration	Gyro-calibration	<b>Calibrate Gyro</b> - Avoid any movements and vibrations during the calibration.
	Invert	Invert mode	Turn the grip in the way that it is over the camera. The new position is recognized automatically. All other above mentioned modes can also be selected in the inverted condition.

# Product Overview

---

## Acoustic signals - Buzzer

Action / Event	Sound sequence
Power on	Initialization sound sequence during system boot up and initialisation
Initialization in process	Be~Bi~Li~Bi~Li
Calibrating	Dn~Dn~Dn~Dn~Dn~Dn
Low battery	Continuous cricket sound

Use the SimpleBGC 32 Bit Software GUI to change the volume of the buzzer or to deactivate the buzzer ▶▶ [5.9 Extended settings for advanced users – View Level „Advanced“](#) ▶▶ [5.12 Buzzer and LED settings](#).

## Scope of delivery



- 1 x Pilotfly C45 gimbal
- 1 x Backpack
- 1 x Universal power adapter 16,8 V  
1000 mA / 100 V ~ 240 V
- 1 x Quick Start Guide
- 1 x Warranty card

# Product Overview

---

## Technical data

Technology	32 bit Alexmos with Triple-MCU technology	
Communication interface	Integrated Bluetooth Version 4.0 / 2402 MHz to 2480 MHz Max. transmitting power 2,5 mW/ Range ca. 10 m	
Operating system	Windows, MAC OSX, LINUX and App Android, iOS	
Number of IMU sensors	Integrated Triple-MCUs with 2 IMU sensors	
Power supply:		
Integrated battery	4S Li-Po 14.8V / 600 mAh	
Battery endurance	ca. 6 hours	
Voltage range	14 V ...16,8 V / 0,11 ... 0,8 A	
Charger – Power adapter	AC 100 ~ 240 V 0,5 A 50 Hz/60 Hz; Modell: FY1681000 Output. DC 16,8 V / 1,0 A	
Movement range	YAW	360°
	ROLL	Left 90°, Right 90°
	PITCH	Top 90°, Down 90°
	Accuracy	min. $\pm 0,01^\circ$ max. $\pm 0,04^\circ$
Unladen weight	ca.498 g (including battery)	
Max. additional load (Motor load)	800 g	
Dimensions	270 x 130 x 110 mm	
Operating conditions	Temperature: -10 °C to max. +40 °C Humidity: 20 - 75 %	
Special features	<ul style="list-style-type: none"><li>▪ Shutter button (only works with Smartphone via Bluetooth connection)</li><li>▪ Supported temperature accelerometer calibration</li><li>▪ 5 user-configurable modes of system operation with a toggle button</li><li>▪ Pitch and YAW angle can be controlled by 4-way-joystick</li><li>▪ Adaptive PID-algorithm for preventing vibrations in big angles</li><li>▪ "ACC low-pass filter" to improve the stability</li><li>▪ Low-voltage protection for integrated battery</li></ul>	

# Table of contents

---

<b>1. IMPORTANT SAFETY INSTRUCTIONS</b>	<b>11</b>
1.1 MEANING OF THE SYMBOLS USED IN THIS INSTRUCTION MANUAL	11
1.2 INTENDED USE	12
1.3 POSSIBLE DANGERS FOR CERTAIN PERSON GROUPS	12
1.4 PERSONAL RIGHT AT THE PICTURE OF ONE'S OWN	12
1.5 THE USE AT CERATIN PLACES AND ENVIRONMENTAL CONDITIONS	13
1.6 POWER SUPPLY AND OPERATING CONDITIONS	14
1.7 PRECAUTIONS AT HANDLING WITH LI-PO ACCUMULATORS	15
1.8 SAFE DISPOSAL	16
<b>2. SETUP AND OPERATING</b>	<b>17</b>
2.1 UNPACKING	17
2.2 FIRST STEPS	18
2.3 ASSEMBLING AND ADJUSTMENT OF THE CAMERA	19
2.4 SWITCH ON AND BASIC OPERATING	21
2.5 FINE-TUNING USING THE SIMPLEBGC GUI SOFTWARE	22
<b>3. MAKING A BLUETOOTH CONNECTION</b>	<b>23</b>
<b>4. SOFTWARE INSTALLATION</b>	<b>24</b>
4.1 INSTALLATION ON WINDOWS	24
4.2 INSTALLATION ON LINUX	24
4.3 INSTALLATION ON MAC OS	25
4.4 INSTALLATION OF THE ANDROID APP	26
<b>5. USING THE SOFTWARE PC/MAC - OVERVIEW</b>	<b>28</b>
5.1 OVERVIEW OF THE SIMPLEBGC SOFTWARE GUI	28
5.2 CONNECTING THE GIMBAL WITH THE SIMPLEBGC SOFTWARE GUI	29
5.3 SAVING AND LOADING PROFILES ONTO THE COMPUTER	30
5.4 WRITING AND READING PROFILES ONTO/FROM THE GIMBAL	30
5.5 MAKING A BACKUP WITH THE BACKUP MANAGER	31
5.6 CALIBRATING THE GYROMETER	32
5.7 CALIBRATING THE ACCELEROMETER	33
5.8 BASIC SETTINGS FOR BEGINNERS – VIEW LEVEL “BASIC”	34
5.8.1 RC-Settings (Remote control, Joystick settings)	34
5.8.2 Follow-Mode	35
5.8.3 Service (Assigning the Mode-button, Startup behavior)	37
5.8.4 Firmware Upgrade	37
5.9 EXTENDED SETTINGS FOR ADVANCED USERS – VIEW LEVEL “ADVANCED”	38
5.9.1 RC-Settings (Remote control, Joystick settings)	38
5.9.2 Follow-Mode	38
5.9.3 Service (Assigning the Mode-button, Startup behavior)	39
5.9.4 Firmware Upgrade	39
5.9.5 Stabilization (Reducing vibrations)	40

# Table of contents

---

5.9.6	Monitoring (Real-Time view of the sensors - raw data)	40
5.9.7	Hardware (Calibration of the gyrometer and accelerometer)	40
5.9.8	Adjustable Variables	40
5.9.9	Scripting	40
5.10	FINE-TUNING BY ADJUSTING THE PID SETTINGS – ADVANCED	41
5.10.1	Manually optimising the PID control settings	41
5.10.2	Automatically optimize the PID control settings	44
5.11	USING THE TIME LAPSE SETTINGS – ADVANCED	46
5.12	BUZZER AND LED SETTINGS – ADVANCED	48
5.13	USING THE DIGITAL FILTER (REDUCING RESONANCE) - EXPERT	49
5.13.1	Notch filter – Reduce vibrations on certain frequencies	49
5.13.2	Low-pass filter – Reduce high-frequency vibrations	50
<b>6.</b>	<b>USING THE ANDROID APP</b>	<b>52</b>
6.1	GIMBAL SETTINGS	52
6.2	MISC SETTINGS	53
6.3	RC SETTINGS	54
6.4	FOLLOW MODE	55
6.5	MONITORING	55
6.6	CONTROL	56
6.7	SETTINGS	57
<b>7.</b>	<b>FAILURE / REPAIR</b>	<b>58</b>
<b>8.</b>	<b>MAINTENANCE AND CARE</b>	<b>60</b>
<b>9.</b>	<b>PUT OUT OF OPERATION, STORAGE, TRANSPORT</b>	<b>60</b>
<b>10.</b>	<b>SERVICE</b>	<b>61</b>
<b>11.</b>	<b>EU DECLARATION OF CONFORMITY (DOC)</b>	<b>62</b>

# 1. Important Safety Instructions

---

Please read these safety instructions attentively before you take your Pilofly product into operation to avoid damages to the product and prevent possible injuries. Keep these safety instructions available for all persons who will use this product.

## 1.1 Meaning of the symbols used in this instruction manual

Warning notices are mentioned in the following chapters in the context in which a danger can appear. They are highlighted especially in the following chapters. The safety instructions within this chapter 1 are generally important and therefore aren't highlighted separately.



**Danger**

Endangering with a **high risk** degree which can mean **danger to life or a heavy injury** in the consequence, if it isn't avoided.



**Warning**

Endangering with a **middle risk** degree which can mean **danger to life or a heavy injury** in the consequence, if it isn't avoided.



**Caution**

Endangering with a low **risk degree** which can mean **minor or moderate injury** in the consequence, if it isn't avoided.



**Caution**

Danger of **damage to property** or **environmental damage**.



**Tip**

Highlights tips and information for you.

# Important Safety Instructions

---

## 1.2 Intended use

This product is provided exclusively for video recordings in the private use. It isn't provided for commercial or industrial use. The delivered power adapter is intended exclusively for the use with the Pilotfly Gimbal. Every other use isn't as designated. Prior condition for the use as designated is the attention of the notes of this instruction manual. Any liability on the part of the manufacturer for damages which result from a use which is not as designated or caused by unauthorized modifications is excluded. Also use only the accessories specified by the manufacturer.

Please pay attention to the local regulations and laws of the country in which you use the Pilotfly Gimbal.

## 1.3 Possible dangers for certain person groups

This device is not designated for the use by children and certain other person groups with restricted physical, sensory or intellectual abilities or lack of experience and/or lack of knowledge. Children and person groups cannot recognize always possible dangers correctly. Therefore pay attention, that ...

- children older than 14 years and above mentioned person groups **ONLY** use the device if they have been supervised by you or a safety responsible person or if they were introduced respectively, but **NEVER** unattended.
- children do not play with or clean or open the device unattendedly. You keep away packing foils! There is danger of suffocation.
- you consider possible dangers for children when you lay the cable, e.g. strangling.

## 1.4 Personal right at the picture of one's own

Pay attention to the restrictions of copyright with regard to filming persons especially at public events, such as exhibitions, stage productions, celebrations, or similar. Even if the photos are for personal use only. The consent of the parents has to be sought especially from minors before capturing a photo. Pay attention to the legal regulations of the country in which you use the device to avoid legal consequences.

# Important Safety Instructions

---

## 1.5 The use at certain places and environmental conditions

For a safe use of your Pilotfly C45 you have to pay attention, that ...

- you use the device only at places which are suitable also for your camera. Implicitly follow the instructions within the instruction manual of the camera which you use with the Gimbal.
- you follow the instructions of restrictions or embargoes for accumulator operated equipment at explosive places. Tank areas and areas where the air is containing chemicals or fine particles, e. g. grain, powdered metal. Explosive areas aren't always identified explicitly.
- you could be distracted when using the device in the current road traffic. This can lead to an accident and you endanger the health of others and yours and you have to expect legal consequences. Therefore use the device at a stationary vehicle. Always notice the legal regulations of the country where you use the device.
- you operate the device only within the permitted environmental temperature range. Details see at ► *Technical data*.
- you do not expose the device to any strong temperature fluctuations. Atmospheric humidity can condense and lead to electrical short circuits.
- you do not expose the device to any direct heat sources, such as heaters, or direct solar radiation. Otherwise it can overheat and be damaged irreparably.
- you avoid the contact with aggressive liquids.
- you avoid the contact with splashing and dripping water.
- you never dive it under water or other liquids.

# Important Safety Instructions

---

## 1.6 Power supply and operating conditions

For a safe use of your Pilotfly C45 pay attention, that ...

- you make sure that the specified voltage data on the rating label are fitting to the specification of the power socket.
- you never grasp the power adapter with wet hands. If you want to pull the power adapter out of the power socket, you always pull directly at the power adapter. Never pull at the cable, it could be damaged. Furthermore, never transport the device at the cable.
- the cable is not modified, jammed, folded, charged by heavy objects, crossed over by vehicle, comes into touch with heat sources or sharp edges. In addition, it mustn't become a stumbling trap.
- you regularly check the device, the accessories and the cables for damages. If you should notice damages, you may not continue to use the device any more. For repairs send it only to the ► *Pilotfly-Service*.
- you immediately switch off the device, if you notice smoke, unusual noises or smells. Do not continue using it any more before a check was performed by an expert. Send it only to the ► *Pilotfly-Service*.
- you switch the device off and you unplug the power adapter from the power socket before you clean or service it.
- you always pull the power adapter out of the power socket at a thunderstorm. At a thunderstorm the equipment which is attached at the power grid can be damaged.
- you do not touch the device during a thunderstorm. Touching metal parts during a thunderstorm can cause an electric shock.
- you use the power adapter only indoors and dry surroundings.
- you do not cover the power adapter to avoid a damage by not allowed temperature rise.
- the power socket is near by the connected device, so that you easily have access to separate the device from the power grid in case of failure.

# Important Safety Instructions

---

## 1.7 Precautions at handling with Li-Po accumulators

Li-Po accumulators require special handling. Improper handling can shorten the life time or lead to fire or explosions, bleeding or overheating. Pay attention, that ...

- you only use the power adapter which is contained in the scope of delivery for charging the accumulator of the Pilotfly C45. Generally, for charging Li-Po accumulators only use battery chargers with a Li-Po charging program and balancer. Charge the accumulator only supervised on a fire-proof pad.
- you replace the accumulator only by an identical or equivalent type.
- you pull the power adapter out of the power socket after finished the charging process.
- you do not throw an accumulator into open fire nor submit heat to it.
- you do not open, do not disassemble and do not deform accumulators.
- you do not drop or push accumulators.
- you do not transport or store accumulators together with objects made of metal, such as paper clips or hairpins. There is a short circuit if the poles of an accumulator come into touch with metal objects. Therefore, use fire protection bags for the storage e.g. protective covers like Lipo-Bags, Lipo-Safety Bags. These are fire-resistant and protect against open fire. In the case of a fire use CO<sub>2</sub>, powder or foam extinguishers. Do not use water. For storage and for the transportation use the same means.
- you do not charge accumulators next to inflammable media.
- during longer non-utilization you store the device within the delivered carrier bag at a cool and dry place. Best at environmental temperatures from +15°C to +25°C. Avoid places with extreme temperatures.
- you absolutely keep the accumulators away from children. The cells look like "chewing gum" or "chocolate" in the packing and can be swallowed. In case a cell has been swallowed immediately call a doctor to help. Due to the poisonous substances within the accumulators, there is serious danger! Keep the accumulators in a way that unauthorized persons have no access, especially not children and animals.
- accumulators getting hot when charging. Never touch hot accumulators! Otherwise there is the danger of burnings!
- you do not exchange accumulators in potentially explosive surroundings. Spark blow arising from it can cause an explosion!

# Important Safety Instructions

---

## 1.8 Safe disposal



Endangering health and environment by accumulators and batteries!

In the European Economic Area this symbol indicates that consumers are required by law to return all waste batteries to either a store or another collection point for waste batteries. Waste batteries should never be placed in the household garbage, or anywhere in the environment. This is indicated by the symbol comprising a crossed-out wheeled bin that appears on batteries and/or battery packaging. In the interest of facilitating waste battery collection, manufacturers of portable batteries have established a joint collection.

Retailers are required by law to take back waste batteries free of charge. In Germany, collection boxes in which consumers can deposit waste portable batteries are available at all stores that sell portable batteries, e.g. supermarket, discounter, drugstore or construction market. Some municipalities take waste batteries back, e.g. via vehicles that make regular collections of hazardous waste, or recycling centres.

The legal limit for mercury within button cells is 2 percent (20 grams per kilogram) of mercury, while the limit for all other types of batteries is 0.005 percent (5 milligrams per kilogram). Portable-battery cadmium content is limited to 0.002 percent (20 milligrams per kilogram). Batteries used for cordless power tools, emergency or alarm systems emergency lighting, and medical devices are exempt from this limit.

For batteries whose mercury, cadmium or lead content exceeds specific limit values, this fact must be indicated on the battery or packaging, below the symbol of the crossed-out whelled bin.

Please take care e. g. by taping the individual connection poles that the batteries to be disposed of are unloaded and the connection poles are protected from short circuits.



Potential negative consequences to the environment and human health!

In the European Economic Area this symbol indicates that this product shall not be treated as household waste. Instead it has to be taken to an applicable collection point for the recycling of electrical and electronic equipment. By ensuring this product is disposed of correctly, you will help prevent potential negative consequences to the environment and human health, which could otherwise be caused by inappropriate waste handling of this product.



In the European Economic Area this symbol indicates that you should dispose the packing materials environmentally sensible according to the local regulations.

## 2. Setup and operating

---

### 2.1 Unpacking



#### **Danger**

**Serious danger!** Keep packing foils away from children. There is danger of suffocation.



#### **Danger**

**Serious danger!** Absolutely keep accumulators from children away. If a child swallowed a cell immediately call a doctor to help. Keep the accumulators in a way that no unauthorized persons have access, especially children and animals.



#### **Caution**

**Environmental damage!** In principle send the device in the original packing so that it doesn't take damage. Therefore, keep the packing. Packing materials which is no more required dispose of environmentally sensible according to the local regulations.



#### **Tip**

**Tip!** Watch our video on YouTube to get a quick overview about unpacking and first steps how to install and use the gimbal:

<https://www.youtube.com/watch?v=zdNS9fiZtCQ>

1. Open the transport box very carefully to prevent a possible damage to the product. This can happen if a knife is used for opening with a long blade.
2. Your Pilotfly product is in its own carrier bag. Unpack it and all its accessories.
3. Please check the completeness and integrity of the scope of delivery.
4. Contact us immediately ► *Pilotfly-Service*, if parts should be missing or are defect.

# Setup and operating

## 2.2 First steps - charge the accumulator



### Warning

**Injury danger!** Check the device and the cable before every use. A damaged device may not be used.



### Warning

**Injury danger!** Do not take the device in operation in explosive surroundings! Follow the safety instructions to this ► *1.5 The use at certain places and environmental conditions.*



### Tip

**Function!** Before the first use, charge the accumulator that the device works optimally.



### Warning

**Injury danger!** Never grasp the power adapter with wet hands.



### Caution

**Property damage!** Use only the delivered power adapter for charging.



### Caution

**Property damage!** Before plugging the power adapter in to the power socket, make sure that the electrical data indicated on the rating label agree with the specification of your power socket. Follow the safety instructions ► *1.6 Power supply and operating conditions.*



### Caution

**Property damage!** Always unplug the power adapter only directly. Never pull at the cable, it could be damaged.



1

1. Put the power adapter into the fitting power socket. Connect the connecting plug with the charge jack.
2. The LED of the power adaptor shines red.
3. The LED of the power adaptor shines green when the charging process is completed. After the completed charging process pull the power adapter out of the power socket again.

# Set up and operating

## 2.3 Assembling and adjustment of the camera



### Warning

**Injury danger!** Implicitly follow the safety instructions and warning notices within the instruction manual of your camera!



### Caution

**Property damage!** Implicitly do not unscrew the locking screw of the roll axis completely. Otherwise, the camera with L-arm to the pitch motor will drop down and the wiring which is arranged behind will be damaged.



### Tip

**Function!** Make sure that both, the camera and the Gimbal remain switched off during the assembly and adjustment.



### Tip

**Tip!** Watch our video on YouTube how to install and balance the camera: <https://www.youtube.com/watch?v=SAkNv1WpnXE>

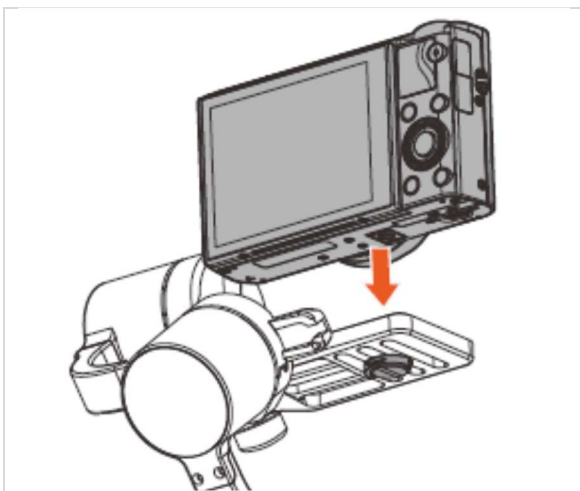

2

1. Remove the objective lid and make sure that the battery is fully charged and the memory card is installed in the camera before you attach the camera to the Gimbal.
2. **Mount camera on the plate.** Ensure that the camera is as close as possible to the pitch motor. The screw can be removed and placed into the other slot if necessary.

# Setup and operating

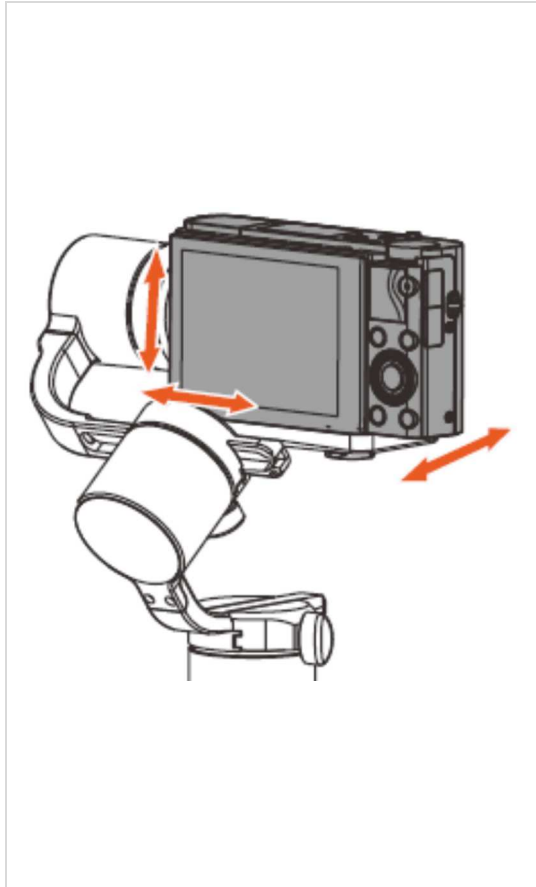

3

3. Hold the Gimbal vertical, ideally supported on a table.
4. **Balancing the pitch axis.** Bend the camera approx. 90 ° forwards or backwards. Loosen the locking screw of the Pitch axis a little bit and push the L-arm in its guidance forwards or backwards, until the camera keeps the position independent again.
5. Tighten the locking screw again.
6. **Balancing the roll axis.** Align the camera forwards looking again. Now the camera should keep independently its position and may not tip forwards or backwards any more. Perhaps, you must correct a little bit. Loosen the locking screw of the roll axis a little bit and push the L-arm in its guidance on to the left or on to the right, until the camera keeps the position independent. **Implicitly do not unscrew the locking screw of the roll axis completely!**
7. Tighten the locking screw again.

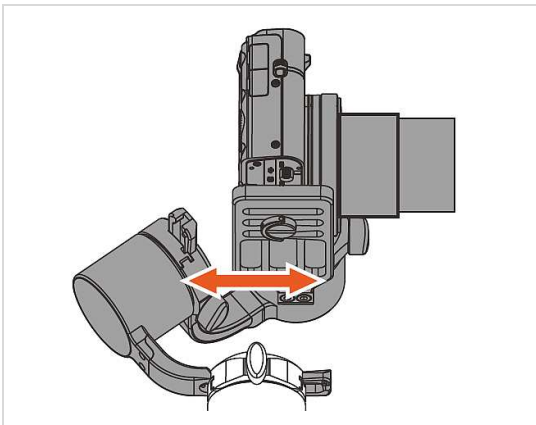

4

8. **Balancing the yaw axis.** Incline the device by approx. 45° to the left or to the right. The yaw axis must keep its position now. If the axis turns, you must proceed balancing the axis.
9. Loosen the locking screw of the yaw axis and move the L-arm forwards or backwards. Find the position where the yaw axis independently keeps its position inspite of holding the Gimbal tilted.
10. Tighten the locking screw again.



## Tip

**Function!** After all, check the tight fixation of all screws well so that the adjusted balance remains unchanged. Only if the camera is already well balanced you will have an optimal stabilization result with reduce load on to the motors. Furthermore, the battery life will be increased.

# Setup and operating

## 2.4 Switch on and basic operating



### Warning

**Injury danger!** Before you switch on the device, please read the instruction manual completely and get familiar with all use and safety instructions. Follow the notes and tips so that you can use the device optimally.



### Tip

**Function!** During processing a programmed script, the joy-stick is locked.

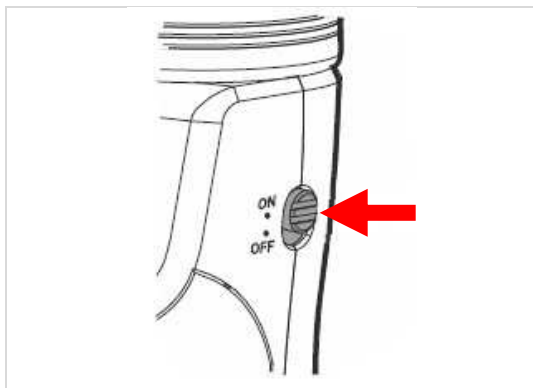

5

1. **Power On / Off.** Hold the device with an assembled camera upright and slide the switch into the "ON" position. The device will be initialized and you hear a sound sequence. The LED display shines green.
2. After switching on, the device is in the follow mode. The device is ready to use.

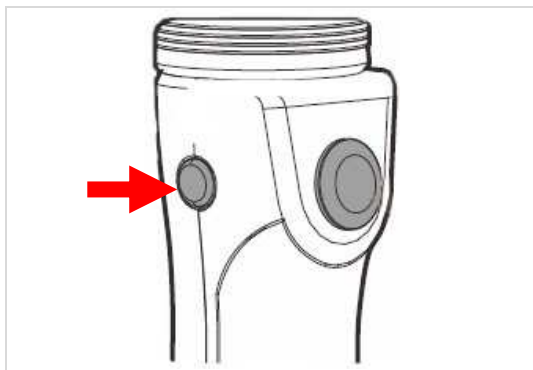

6

3. **Using the "Mode"-key button.** Set the desired operating mode or function with the "Mode"-key button ▶ *Product overview* ▶ "Mode"-key button.

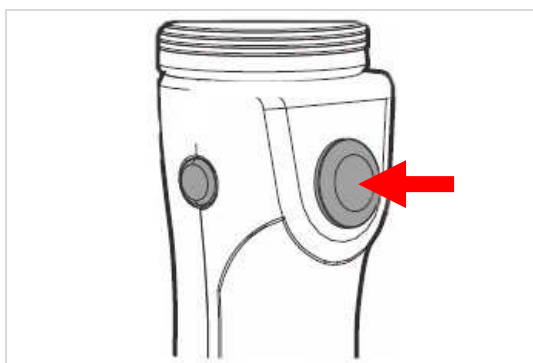

7

4. **Using the joystick.** Use the joystick to pan and tilt the camera.

# Setup and operating

---

## 2.5 Fine-tuning using the SimpleBGC GUI software



Tip

**Function!** Create the best possible stabilisation effect by using the SimpleBGC software ▶ *5. Software user surface (GUI)*. As every camera has a different weight, the settings for the **PID controller and the motor output** can be individually set and optimized. You can only achieve the best results with regard to stability when using the optimal fine settings.

### 1. PID control settings for all 3 axes

**P** – describes the **reaction strength** to disruptions. The higher the set value the stronger the compensation of disruptive influences. Test your selected thresholds by moving the Gimbal in line with your planned application, which axis starts vibrating in which position. If you still observe vibrations, you have to adjust the P value and the D value mutually ▶ *5. Software user surface (GUI)* ▶ *5.10 Fine-tuning by adjusting the PID settings – ADVANCED (for very light or heavy cameras)*

**I** – The I value determines the **speed of movement** of the respective axis, if you control the device using the joystick or using the RC commandos and the SimpleBGC software. In the case of low values you get a slow and uniform movement of the respective axis. Increase the value for more rapid movements. Please note that rapid movements can be more vulnerable to faults.

**D** – The D value reduces the **reaction speed**. This value dampens the low-frequency vibrations. A D value that is too high causes high-frequency vibrations in particular when the IMU sensor is stimulated by external vibrations.

### 2. Adjusting the motor output to the camera weight ▶ *5. Software user surface (GUI)*

You can adjust the necessary supply voltage for the respective motor to the weight of your camera. The setting range for the voltage values is 0-255, 255 corresponding to the maximum battery voltage. If the values set are too low, the respective motor does not have enough power to move the corresponding axis in connection with your camera and to stabilize it sufficiently. Set the lowest value, which can guarantee a sufficient holding torque and solid stabilization without the casing becoming hot.



Caution

**Damage to property!** Voltage that is set too high for the motor output causes a strong heating of the motor. High temperatures above 80°C lead to motor damage. Handle the settings carefully and considerately!

### 3. Making a Bluetooth connection

---



Tip

**Legal hint!** All Pilotfly products are equipped with an active Bluetooth to be able to make a wireless connection with the device and control this via remote control. Probably there are restrictions at certain places for the use of a Bluetooth-capable and wireless equipment. Please, if you aren't sure whether you may use a wireless device in certain surroundings (e. g. airplane or hospital), ask the responsible persons before you switch on the device and activate Bluetooth with that.



Tip

**Function!** Bluetooth and Wireless LAN equipment work in the same frequency domain and can disturb themselves under each other.



Tip

**Function!** Note that not coupled equipment only can be found if their visibility is switched on.

1. Open the Bluetooth settings at your PC, MAC or android smartphone, and look for a new bluetooth device while your Pilotfly device is switched on.
2. Follow the instructions on the display.

**Make a connection (Pairing).** Please, on request of a password enter the following password **1234**.

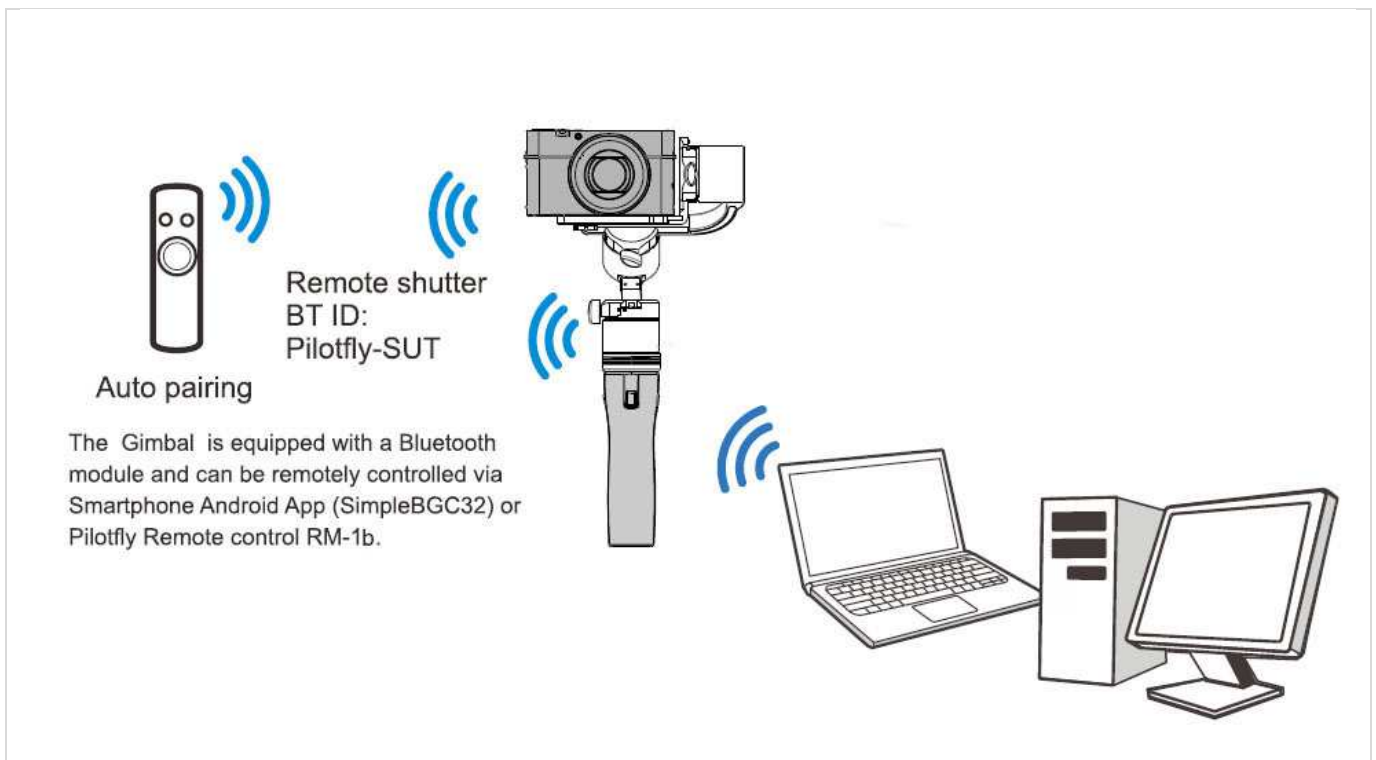

## 4. Software Installation

---

All Pilotfly products use the **Alexmos Chip** and therefore can be used with the **SimpleBGC** software which is provided by **Basecam Electronics**. The software can be installed on different operating systems, such as Windows, OSs, Linux and Android App.



### Tip

**Compatibility problems!** The most actual driver version (6.7.4) for Windows can lead to problems with the connecting or data communication. This is to be seen in a raised reaction of the SimpleBGC software. If this should be the case, please download and install the driver version 6.7.2.

### 4.1 Installation on Windows

1. Go to our website [www.pilotfly.de](http://www.pilotfly.de) or [www.pilotfly.com.tw](http://www.pilotfly.com.tw) on to the support page.
2. Download the most current version of the SimpleBGC software there.
3. Download the most current version of the "CP2102 USBtoUART" driver there.
4. Install the driver CP2102 USBtoUART.
5. Extract the SimpleBGC Software and start the Software with **SimpleBGC\_GUI.exe**

### 4.2 Installation on Linux

1. Go to our website [www.pilotfly.de](http://www.pilotfly.de) or [www.pilotfly.com.tw](http://www.pilotfly.com.tw) on to the support page.
2. Download the most current version of the SimpleBGC software there.
3. Extract the SimpleBGC Software and start the Software with **run.sh**

# Software Installation

## 4.3 Installation on MAC OS

1. Go to our website [www.pilotfly.de](http://www.pilotfly.de) or [www.pilotfly.com.tw](http://www.pilotfly.com.tw) on to the support page.
2. Download the most current version of the SimpleBGC software there.
3. Download the most current version of the "CP2102 USBtoUART" driver there.
4. Ensure, that you have installed Java Run Time.
5. Install the driver CP2102 USBtoUART.



### Tip

**Function!** The software SimpleBGC of Basecam Electronics uses a virtual COM interface. Thus, you must create lock file before, that the software works under OSs. Proceed very attentively as follows for it especially if you are less experienced:

- Start the terminal under „Utilities“:



- Create a folder „/var/lock“ with the following command:  
**sudo mkdir /var/lock**
  - Password-Request by MAC OS. Enter your Log-In password and confirm by pressing **Enter**.
  - Change the release of the prepared folder with the following order: **sudo chmod 777 /var/lock**
  - Either allow your system to run non-signed applications by setting this in System Preferences > Security & Privacy > General > Allow Applications downloaded from: **Anywhere**; Or you can allow just this one app to run by answering **Open** when prompted by the system dialog.
6. Extract the SimpleBGC Software
  7. Enter the command "chmod+u+x" into the terminal followed by a blank (Space) and the path to the file "stm32ld\_mac" in the folder "bin" within the application folder (use drag&drop to copy the entire path and to paste into the terminal). Confirm by pressing Enter to execute the command.
  8. Start the Software with **SimpleBGC\_GUI.jar**
  9. Select **/dev/tty.SLAB\_USBtoUART**  
In the connection drop down menu and press **Connect**.



# Software Installation

## 4.4 Installation of the Android App



### Tip

**Function!** A new version of the Android App is available soon. You can still use the Android application by downgrading the firmware of your Gimbal to version 2.56b9.

Function! Implicitly make a backup of the entire Gimbal settings and save your profiles on a computer before you change the firmware of your Gimbal. Existing data will be deleted ▶▶5. Using the Software PC/MAC ▶▶5.3 Saving and loading profiles onto the computer and chapter ▶▶5.5 Making a backup with the backup manager.

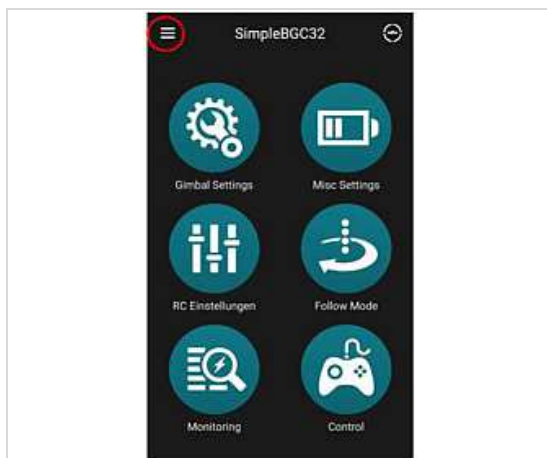

A

1. Go to the Google Play Store and download the SimpleBGC App there.
2. Ensure that Pilotfly product is paired with your Android Smartphone or Tablet ▶▶3. Making a bluetooth connection.
3. Start the SimpleBGC32 Android App and connect to the paired device by extract the menu left corner.

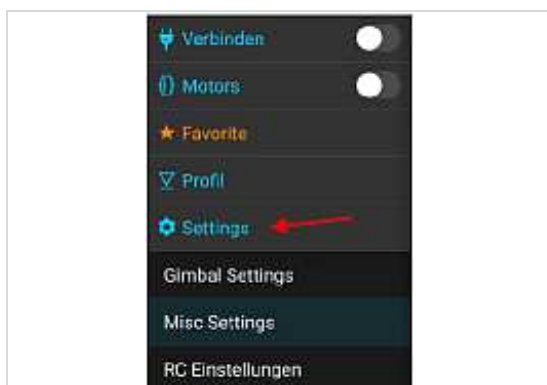

B

4. Then press on „Settings“.

# Software Installation

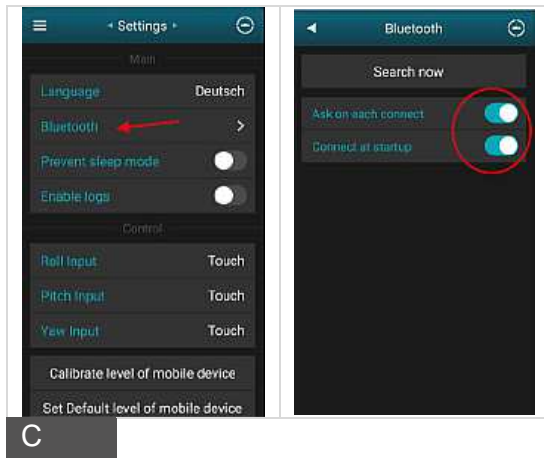

5. Then press on „Bluetooth“ and search for new devices. Enable „Ask on each connect“ and „Connect at startup“.

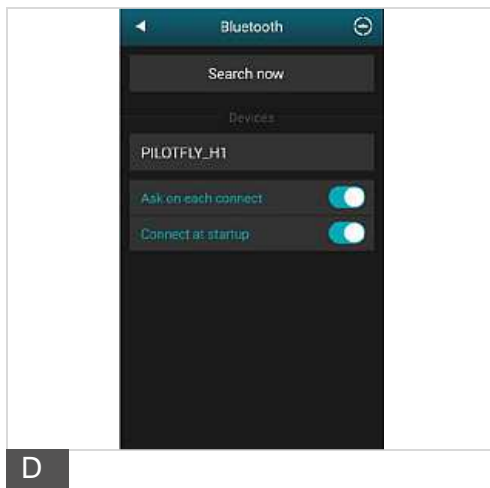

6. The Bluetooth window should show you detected devices as shown.

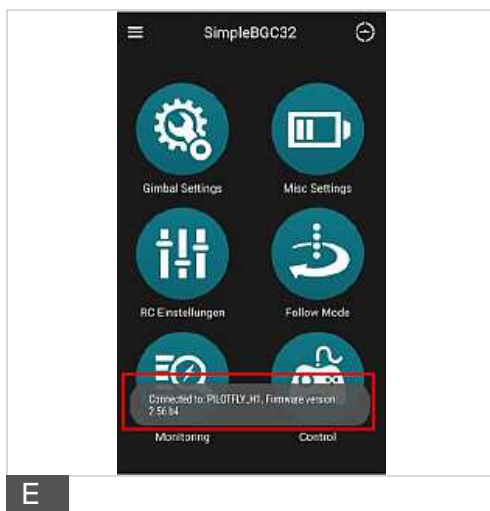

7. Close the application and start it again while the Pilotfly device is powered on.
8. While starting the application the App tries to connect with the Pilotfly device and will show a Pop-up window with information of proper connection and current firmware version.
9. Now the application is ready to use with your Pilotfly device.

## 5. Using the Software PC/MAC - Overview



**Tip**

**Function!** Connect the device via USB cable or Bluetooth ▶ 3. *Making a bluetooth connection* with a PC or MAC to optimize the stabilization settings or to upgrade the firmware.



**Tip**

**Function!** Implicitly make a backup copy of your profiles before you make changes or upgrade the firmware. Additionally, make a backup of the complete Gimbal configuration by using the backup manager.



**Tip**

**Function!** Make sure that the software version (indicated on top in the SimpleBGC GUI window frame) corresponds at least to the firmware version of the connected Gimbal (indicated in the window below the check box "BLE").



**Caution**

**Property damage!** Don't make any changes in the register "ENCODERS" in the view (View level) "EXPERT" or "DEVELOPER".

### 5.1 Overview of the SimpleBGC software GUI



- RC-Settings
- Follow Mode
- Service
- Firmware Upgrade

- Stabilization
- Hardware
- Monitoring
- Scripting
- Adjustable Variables
- RC-Settings
- Follow Mode
- Service
- Firmware Upgrade

# Using the Software PC/MAC – Connecting

The surface is separated into different functional blocks. Under the main menu point "View" you choose the desired configuration depth (View level). Depending on your user abilities you can set to display more or less functional blocks for various settings. For beginners, we recommend the view "BASIC". If you are already a little bit familiar with the functionality of your Gimbal and the software, you can use the view "ADVANCED" for advanced users. For the use of the extended functionalities in the views "EXPERT" and "DEVELOPER" please refer to the respective current version of the instruction manual of the SimpleBGC software. Note that the use happens on your own risk. Pay attention to the safety hints.

## 5.2 Connecting the Gimbal with the SimpleBGC Software GUI

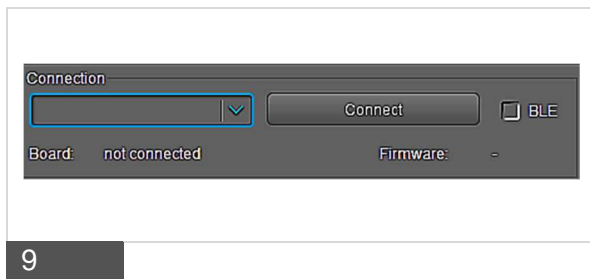

### 1. **USB-cable-connection.**

Connect the device with a Micro-USB cable. Choose the COM interface in the drop-down menu and press the button "Connect". Observe the connection status shown in the lower area of the window.

### 2. **Bluetooth-connection.** (Optional)

Alternatively connect the device via Bluetooth. Mark the check box "BLE", choose the COM interface in the drop-down menu and press the button "Connect".

The connection status is shown on the lower area of the window. At a successful connection, all preinstalled profiles are downloaded from the device. The settings of the current profile are displayed.

# Using the Software PC/MAC – Profiles

## 5.3 Saving and loading profiles onto the computer

A profile corresponds to a set of predefined settings, as for example different default settings for the follow mode, the rotation speed of the single axes, the orientation of the axes when switching on, time-lapse settings, axis acceleration, control parameters respectively adapted on your camera weight for the optimum reduction of vibrations, parameters for jerk-free operating, etc.).

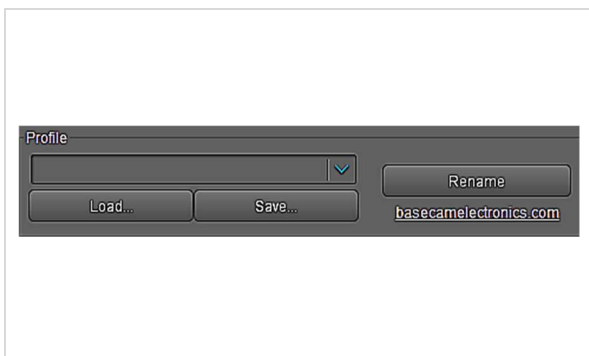

10

1. **Save a profile onto the computer.**  
Store the current profile by pressing the button "Save". You can rename the profile by pressing the "Rename"- button.
2. **Open profile from computer.** Press the button "Load" to open and load the settings of a stored profile. The settings of the loaded profile are displayed.



Tip

**Function!** Over the „File“ menu you are able to load and save all profile files at the same time by pressing „Load profile(s) from a file...“ and „Save all profiles to a file...“. Settings with related to the hardware and sensor adjustment as well as their configuration stay the same for all profiles.

## 5.4 Writing and reading profiles onto/from the Gimbal



11

1. **Upload a profile to the device.**  
Upload the current profile to your device by pressing the button "WRITE". Only the current displayed profile will be transferred!
2. **Download a profile from the device.**  
Download all profiles from the device by pressing the button "READ". The current profile is displayed.



Tip

**Function!** With the successful connecting of your Gimbal with the SimpleBGC software GUI all profiles within the device are read out. Implicitly save your profiles before you change any settings and write them onto your Gimbal ▶▶ 5.3 Saving and loading profiles.

# Using the Software PC/MAC – Backup manager

## 5.5 Making a backup with the backup manager

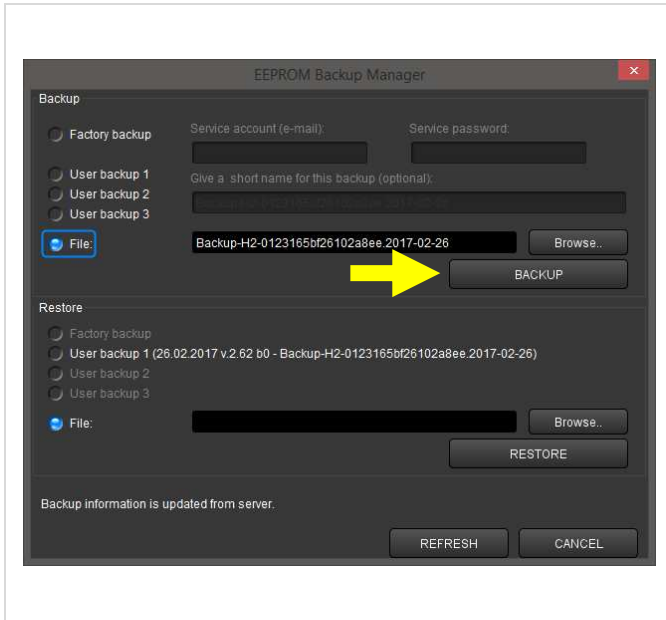

12

1. **Making a backup in a file on your computer.** Define a name for your backup file and save your backup as a file on your computer or other data storage of your choice. By pressing "Browse" you define the target folder. Press the button "Backup" to confirm the saving of your backup file.
2. **Making a backup onto our server.** You can save up to three backup files onto our server. Select the number of your choice (User backup 1-3) and define a name for your backup file. Press the button „Backup“, to save the backup file onto our server. Herewith you have access to your backups everywhere when you are conected with the internet.

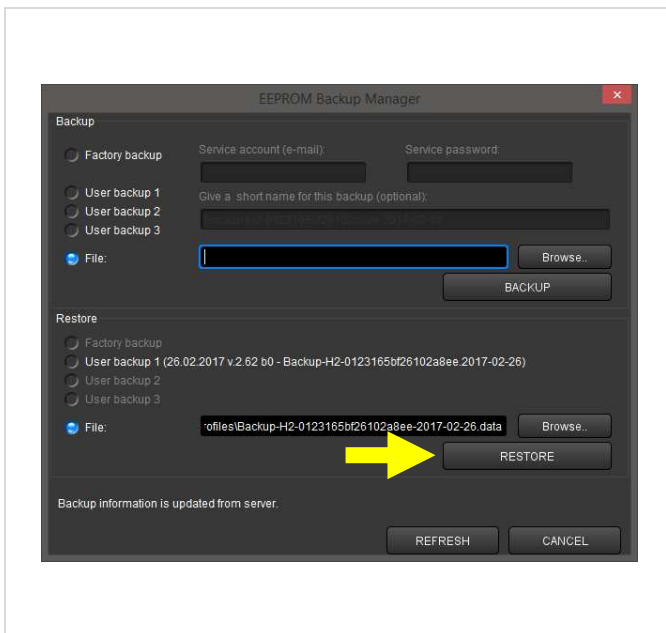

13

1. **Restore a backup from a file on your computer.** Press the “Browse” button and select your backup file on your computer or other data storage. Then press the button „RESTORE“. The backup will be restored.
2. **Restore a backup from a file on our server.** Select the wanted backup file (User backup 1-3) and press the button „RESTORE“. The backup will be restored. Furthermore, you can see the option “factory backup”. For all delivered Gimbals since Januar 2017, we have already made a backup-file of the factory presettings for you.

You must have a functioning internet connection.

# Using the Software PC/MAC - Gyrometer

## 5.6 Calibrating the Gyrometer



Tip

**Function!** Implicitly make a backup copy of your profiles before you make changes or upgrade the firmware. Additionally, make a backup of the complete Gimbal configuration by using the backup manager.



Tip

**Tip!** Watch our video on YouTube how to calibrate the gyro- and accelerometer: <https://www.youtube.com/watch?v=IxpdtzvizoQ>

A calibration of the Gyrometer is necessary for the exact determination of the orientation of the camera in the Pilotfly-Gimbal. Though the sensors are calibrated before delivery, however, sometimes you must perform a calibration of the Gyrometer. The Gyrometer measures the rotations of your camera in the Gimbal. With the software, a calibration is possible as shown below.

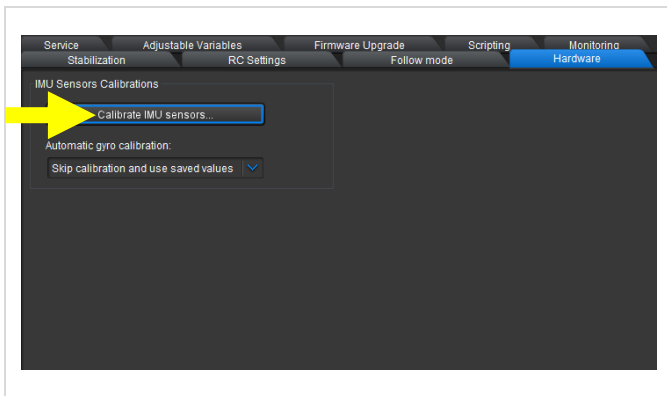

14

1. Press the button „Calibrate IMU sensors“ within the register tab „Hardware“.
2. Take care, that the Gimbal stands stable and without any vibrations. The orientation of the camera isn't important.
3. The display of the Gyroscope should be ideally within the green range.

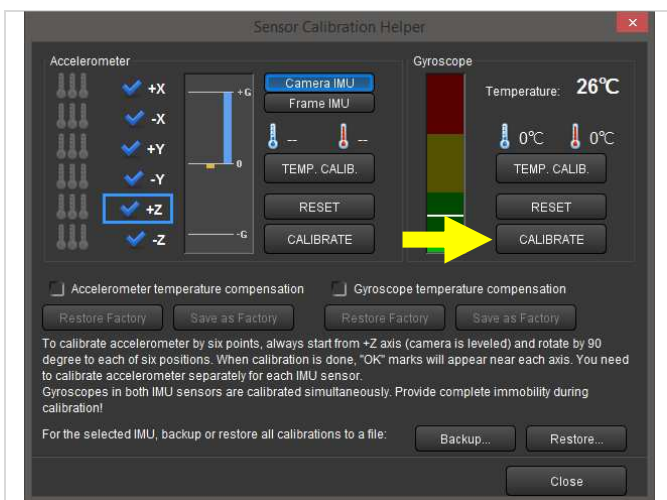

15

4. Press the button „RESET“ and then the button „CALIBRATE“ within the function block „Gyroscope“ as shown in figure 21.
5. During the calibrating process you can hear an acoustic signal and you see a beam display to 100% in the window.
6. The calibrating process needs a few seconds. The beam display disappears after reaching the 100 % and the acoustic signal is finished if the Gyrometer is final calibrated.

# Using the Software PC/MAC - Accelerometer

## 5.7 Calibrating the Accelerometer

A calibration of the acceleration sensors is necessary for the exact determination of a position change of the camera. Though the sensors are calibrated before delivery, however, in rare cases you must carry out a calibration of the acceleration sensors. These measure linear movements of your camera in the Pilotfly-Gimbal. With the software, a calibration is possible as shown below. You need to carry out only a simple calibration of the +Z axis. A calibration of all six axes is not necessary.

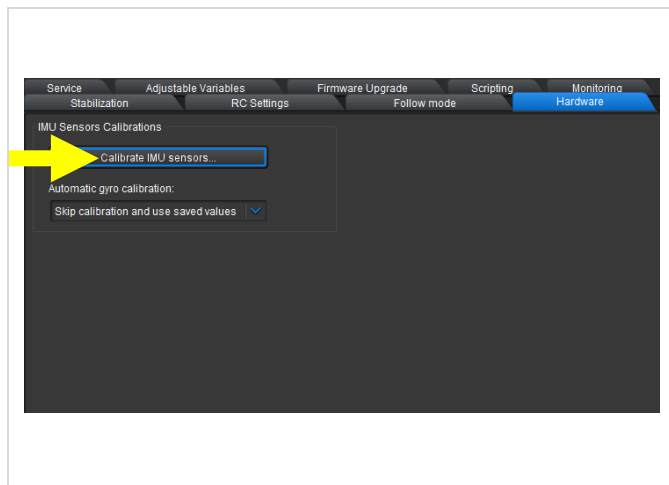

16

1. Press the button „Calibrate IMU sensors“ within the register tab „Hardware“.
2. The orientation of the camera is now very important. Align the camera in the Gimbal absolutely horizontally (e.g. by putting it on a flat surface). If your camera supports an integrated water level bubble, use it to check the horizontal orientation.
3. Take care, that the Gimbal stands stable and without any vibrations.

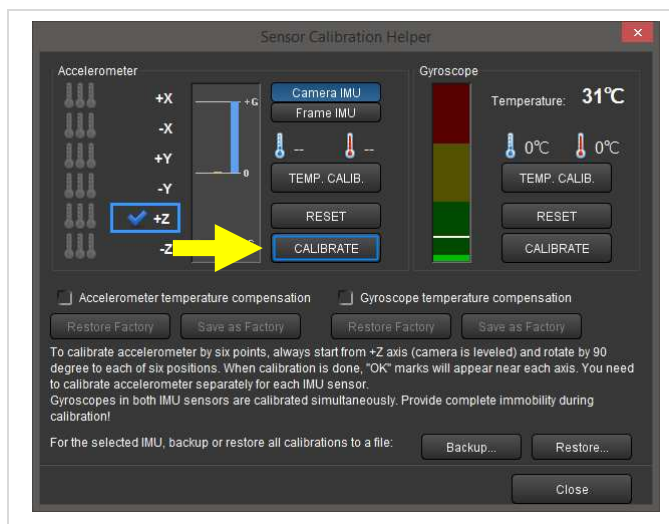

17

4. Press the button „RESET“ and then the button „CALIBRATE“ within the function block „Accelerometer“ as shown in figure 23.
5. During the calibrating process you can hear an acoustic signal and you see a beam display to 100% in the window.
6. The calibrating process needs a few seconds. The beam display disappears after reaching the 100 % and the acoustic signal is finished if the Gyrometer is final calibrated.
7. After a successful calibration, a hook appears before the **Z-axis**.

# Using the Software PC/MAC - BASIC

## 5.8 Basic settings for beginners – View level “BASIC”



### Caution

**Property damage!** The software SimpleBGC offers many versatile possibilities. These extended functions found at view level “**EXPERT**” and “**DEVELOPER**” are not within the context of this introduction manual. For the use of this extended functionality we refer you to the software user manual SimpleBGC 32bit 3-Axis. The performing of functions which aren't described to your Pilotfly product within the context of this instruction manual happens on your own responsibility. We don't assume any liability for damages resulting from it!

The view level "BASIC" is suitable for beginners. Here you have access to the basic features of your Pilotfly Gimbal to reach an optimized stabilisation of your camera:

### 5.8.1 RC-Settings (Remote control, Joystick settings)

The control of your Gimbal via remote control or joystick is reached by means of RC (Remote Control) signals:

**Angle Mode** – The RC stick will control the camera angle directly. The full RC range will cause a camera to go from min to max angles, as specified at Min. Angle and Max. Angle.

**Speed Mode** – As long as you operate the joystick the respective axis will move with the set speed (speed 0 ... 255). (Default setting for Pilotfly Gimbals: activated)

**INVERSE** – Set this checkbox to reverse direction of rotation relative to stick movement.

**LPF** – Reaction speed (Low Pass Filtering 0...16) for joystick commands. The higher the value is, the smoother the reaction is to stick commands. But the reaction speed will be increased.

**Initial Angle** – With selected speed mode the set angle is the angle directly after switching on or after performing a move to zero position. (Home-Move 5 x pressing the Mode-button ▶ *Product overview – Mode-button*).

**Do not update initial angle** – Set this option to not update the initial angles in the EEPROM after executing "Set tilt angles by hands" menu command or other commands. If not set, system will start with the new initial angles next time. (Default setting for Pilotfly Gimbals: activated)

**Limit Accelerations** – The lesser the value is the smoother the camera rotation under control is. „0“ deactivates the limitation completely.

**ROLL, PITCH, YAW RC Sub-Trim** – Correction for transmitter inaccuracy central point trimming. Central point here is PWM 1500 (blue beam display within the RC register tab). It's better to trim it in the transmitter. But in case of it is not possible (when using joystick, for example), you can use AUTO function in the GUI. Just place stick in neutral position, and press AUTO button. Actual data becomes new center point. Press WRITE button to apply settings.

Blue beam display: Central point is PWM 1500

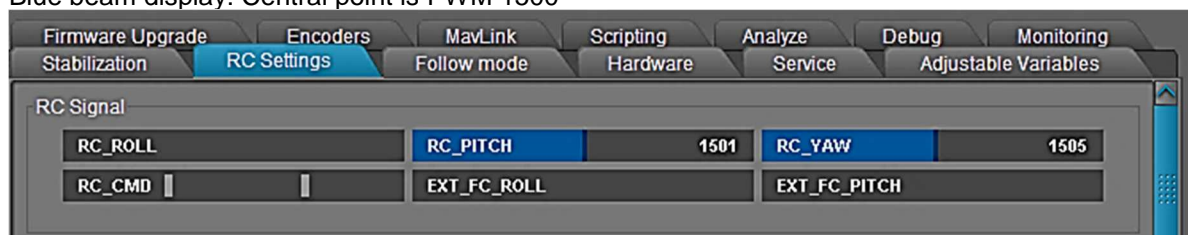

# Using the Software PC/MAC - BASIC

## RC-Settings (Joystick settings) - Continued

**Deadband around center** – Set a dead zone around the neutral centre of the remote control or the joystick to eliminate accidentally drifting by shaking or RC inaccuracies.

**Expo curve** – Function provided only with selected speed mode. Higher values slow down movements around the neutral position of the remote control what allows a more exact manual positioning for small movements. Nevertheless, big movement segments become more inexact.



### Tip

**Tip!** Watch our video on YouTube how to setup the RC-settings:  
[https://www.youtube.com/watch?v=y\\_-kQxFqcPk](https://www.youtube.com/watch?v=y_-kQxFqcPk)



### Caution

**Function!** The software SimpleBGC offers further possibilities, which are however not necessary for the use and the adjustment of the Pilotfly Gimbals. Thus, these functions are not described within the context of this introduction manual. For the use of this extended functionality we refer you to the user manual of the SimpleBGC 32bit 3-Axis software, which you can download in its newest version from our web side [www.pilotfly.de](http://www.pilotfly.de). The performing of functions which aren't described to your Pilotfly product within the context of this instruction manual happens on your own responsibility. Pay attention to the safety hints.

## 5.8.2 Follow-Mode

The follow mode is a special mode with which the camera follows the movements of the Gimbal. We already have set for you the most useful modes of operation for the follow mode in the profiles from 1 to 4, which you can adjust directly over the Mode-button by quick choice ►►Product overview – Mode button.

Here you can set further settings for the follow mode:

**Disabled** – The roll-axis and the pitch-axis are locked. The additional locking of the yaw-axis and completely deactivating of the follow mode, you can decide by marking the check box "Follow Yaw".

**Follow Yaw** – Deactivate this check box to lock the yaw-axis. Together with the setting "Disabled" all three axes are locked and the follow mode is deactivated completely. The camera keeps its orientation independently of the orientation of the Gimbal.

**Follow Flight Controller** – The camera can follow additional signals of an external control. Because this option is not needed for the standard use and additional settings under the View level "Advanced" would be necessary, we refer you to the software user manual SimpleBGC 32bit 3-Axis.

**Temporarily disable follow mode** – Mark this check box if you want to deactivate the follow mode temporarily (< 5s) as long as you press the Mode-button. Then the camera keeps its orientation independently of the orientation of the Gimbal.

# Using the Software PC/MAC - BASIC

## Follow-Mode - Continued

**Follow Frame** – Here you can set additional criteria, when the roll-axis should be unlocked and should follow the orientation of the Gimbal. Namely as a function of the orientation of the pitch.

**Follow ROLL start,deg** – Set the angle (in degrees) of the camera pitching up or down, where the roll axis enters follow mode. Below this angle, roll is in lock mode.

**Follow ROLL mix,deg** – Set the range (in degrees) of the camera pitching, where the roll axis is gradually switched from the 'lock' mode to 'follow' mode.

Anmerkung:

1. The setting Follow ROLL start,deg = 90° and Follow ROLL mix,deg = 0° (90,0) deactivates the follow mode of the roll axis completely.
2. The setting Follow ROLL start,deg = 0° and Follow ROLL mix,deg = 0° (0,0) activates the follow mode of the roll-axis independently of the pitch.

**Deadband** – This setting reduces smaller jerking up to the set angle, for example, if the Gimbal is hand carried. This function is only provided with enabled speed mode.

**Expo curve** – The greater this value is, the more softly and more slowly the movements are in the narrower area of the starting point. But the movements become quicker with increasing angles and the positioning will be exponentially more imprecise.

**Speed** – Here you can set the rotation speed of the single axes in the follow mode.

**LPF** – Over this Low Pass Filter you can reduce jerking at quick movements. The higher the value, the smoother will be the movements. In fact, the adjusting requires some practise, so that no undesirable oscillations occur.



**Tip**

**Function!** For high speed values above 50 it's strongly recommended to set "LPF" parameter greater than 3, "Expo curve" parameter greater than 50, and "Dead-band" parameter greater than 3-5 degrees. Otherwise, wrong system operation is possible, like vibrations and jerks under follow control, and overshoot of target.



**Tip**

**Function!** It's recommended to not set the "LPF" parameter below 2.

# Using the Software PC/MAC - BASIC

## 5.8.3 Service (Assigning the Mode-button, Startup behavior)

You can make different adaptations for your Gimbal and save your respective setting as a profile ► [5.3 Saving and loadin profiles on a computer](#) or directly transfer to your Gimbal ► [5.4 Writing and reading profiles onto/from the Gimbal](#).

Here under the service settings you can assign stored profiles to the Mode-button for a quick access.

Our default assignment you will find under ► [Product overview – Mode button](#).

**Menu button** – Setup which profile you would like to call in which way by pressing the Mode-button, for example, by pressing 1 x to 5 x or keeping pressed.

**Startup Behavior** – Here you can choose additional options, which the Gimbal shall do during or directly after switchin on:

**Center YAW axis relative to frame** (Only provided with encoders)

**Remember last used file**

**Search and move motors to home position** – Mark the respective axis ROLL, PITCH, YAW, which shall move to the defined start position directly after switching on the Gimbal. As default setting we move all three axes to ist defined start position.

## 5.8.4 Firmware Upgrade

Within this register tab you find i.a. the serial number of your device. The actual firmware version is displayed. Press the button "CHECK" whether there is already a newer firmware version for your device.

1. Make sure that you have connected your device with the computer over USB cable and not over Bluetooth.
2. Press the button "Upgrade" to update the firmware version.
3. During the upgrade process the connection will be interrupted, nevertheless, the upgrade is continued.
4. Finally restart the SimpleBGC software.
5. Connect your device with the SimpleBGC software once more.

Now the new firmware version is displayed.



**Tip**

**Function!** Implicitly make a backup of the entire Gimbal settings and save your profiles on a computer before you change the firmware of your Gimbal. Existing data will be deleted ► [5. Using the Software PC/MAC](#) ► [5.3 Saving and loading profiles onto the computer](#) and chapter ► [5.5 Making a backup with the backup manager](#).



**Caution**

**Property damage!** Never remove the USB cable during a firmware upgrade, because the mainboard will be damaged and you cannot connect the gimbal to the software anymore.

# Using the Software PC/MAC - ADVANCED

## 5.9 Extended settings for advanced users – View level “ADVANCED”



### Caution

**Function!** The software SimpleBGC offers further possibilities, which are however not necessary for the use and the adjustment of the Pilotfly Gimbals. Thus, these functions are not described within the context of this introduction manual. For the use of this extended functionality we refer you to the software user manual SimpleBGC 32bit 3-Axis. The performing of functions which aren't described to your Pilotfly product within the context of this instruction manual happens on your own responsibility. Pay attention to the safety hints.

This view level "ADVANCED" is suitable for advanced users. Here you have access to the features which were already described under "BASIC" and additional possibilities for an even finer optimisation of your Pilotfly Gimbal.

### 5.9.1 RC-Settings (Remote control, Joystick settings)

You will find the same settings as described at the basic settings ▶ 5.8.1 *RC-Settings (Remote control, Joystick settings)* and additionally the following extended settings:

**Input Configuration, Spektrum data and bind mode, Analog joystick auto-detection, Mix signal from FC\_ROLL, FC\_PITCH inputs, PWM Bypass**

### 5.9.2 Follow-Mode

You will find the same settings as described at the basic settings ▶ 5.8.2 *Follow-Mode* and additionally the following extended settings:

**Use Frame IMU, if possible, Apply offset correction when axis is not following, Follow rate inside deadband, ROLL, PITCH, YAW Offset, ROLL, PITCH, YAW EXT.FC GAINS**

# Using the Software PC/MAC - ADVANCED

## 5.9.3 Service (Assigning the Mode-button, Startup behavior)

You will find the same settings as described at the basic settings ▶ 5.8.3 *Service* and additionally the following extended settings:

### Working positions –

- **Frame upside-down auto detection** – if enabled, the controller detects startup in the upsidedown mode: if you switch Gimbal ON when frame is turned over by ROLL axes, but camera is not, - system enters upside-down mode automatically. If option is disabled, you have to enter this mode manually by the menu command.
- **Briefcase mode auto- detection** – it's useful in the “Follow” mode, when you turn frame by 90 degree over any axes, and do not want for camera to follow the frame. Converting to briefcase position is very simple – just hold camera and rotate frame by 90 degree. Also, it will be automatically detected at startup, if you have the “Follow” mode enabled by default.
- **Upside-down PITCH auto-rotate** – when the frame is turned upside-down over PITCH motor, camera will be rotated by 180 degrees to track new position of the frame. Be sure that PITCH angle is not limited in the RC tab, to allow camera to make this movement.
- **Set to normal position on profile switch** – normally, camera does not move when you switch to a different profile, but keeps it position. You can enable this option in any profile, to move camera to a neutral position, when switching to this profile.

### Time-lapse-parameters – ▶ 5.14 *Using time lapse settings - ADVANCED*

- **Time-lapse time, sec.** – Enter here the duration for the movements in the timelapse function.
- **Acceleration in and out time, %** – Here you can set how fast the movements should be accelerated or slow down when starting and stopping the movement.
- **Frame angles are fixed – apply gyro drift correction** – Enable the Drift-correction by marking this check box.

### Misc. settings –

- **Emergency stop** – enable this option to immediately stop motors if problems are detected, like I2C-errors, over-temperature, short circuit, etc.  
**Restart system after a delay, ms** – Enter the delay time until the system shall restart.

### Buzzer and LED – ▶ 5.12 *BUZZER and LED settings - ADVANCED*

In this functional block you can activate the Beep tone for the given functions or deactivate it or set its volume.

## 5.9.4 Firmware Upgrade

All settings are as described at ▶ 5.8.4 *Firmware Upgrade*. There are no extended options for advanced users.

# Using the Software PC/MAC - ADVANCED

## 5.9.5 Stabilization (Reducing vibrations)

If you feel vibrations by using the Gimbal in combination with your camera, you can optimize and stabilize your system by means of the PID-parameter settings ▶ 5.13 *Fine-tuning by adjusting the PID settings – ADVANCED*

## 5.9.6 Monitoring (Real-Time view of the sensors - raw data)

Use the monitoring of each sensor raw-data stream to detect even the finest irregularities of your device. Optimize and stabilize your system by means of the PID-parameter settings ▶ 5.13 *Fine-tuning by adjusting the PID settings – ADVANCED*

## 5.9.7 Hardware (Calibration of the gyrometer and accelerometer)

Within this register tab you can calibrate your system:

- ▶ 5.6 *Calibrating the gyrometer*
- ▶ 5.7 *Calibrating the accelerometer*

Furthermore, you can choose whether with every switching on of your Gimbal a gyroscope calibration should be automatically performed.

**Automatic gyro calibration** – Our default setting: “Skip calibration and use saved values”

## 5.9.8 Adjustable Variables

Please don't change any settings in this tab for the correct use of your Pilotfly Gimbal.

**Use on your own risk.**

## 5.9.9 Scripting

Please don't change any settings in this tab for the correct use of your Pilotfly Gimbal.

**Use on your own risk.**

# Using the Software PC/MAC – PID control

## 5.10 Fine-tuning by adjusting the PID settings – ADVANCED

In this chapter, we will show you how to optimally set the Gimbal to your camera weight by adjusting the PID control parameter.



### Note

**Tip!** We have saved the optimal PID settings for several standard cameras in a database.

<https://drive.google.com/drive/folders/0B9o3W--165qzbnJVMmpQMethbVk>

### 5.10.1 Manually optimising the PID control settings

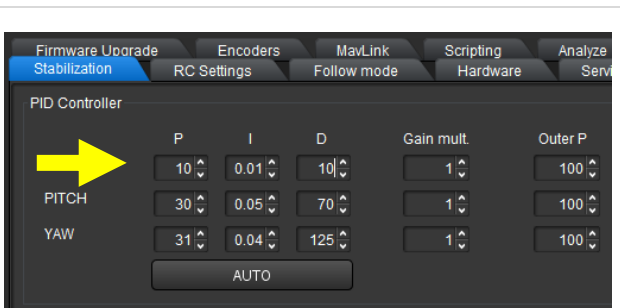

1. **Manually optimize the PID control settings.** Before you start ensure that the Gimbal is stable. For general information on mechanisms of the PID parameter read ▶ 2.5 Fine-tuning using the SimpleBGC software
2. Select the setting **Gain = 1** (direct multiplier for the P and D value) and the value for **Outer P = 100** (speed of angle correction, standard setting Outer P = 100) for all three axes.
3. Optimize the settings as described, only for one axis at a time. When one has been aligned, you can begin with the next.
4. Set the respective axis to **P=10, I=0.01** and **D=10** at the beginning of the values.
5. In the monitoring register you can see how stable your system is. The result after successful fine-tuning can be seen in the adjacent illustration and below that an example of when the system is not yet working stably.

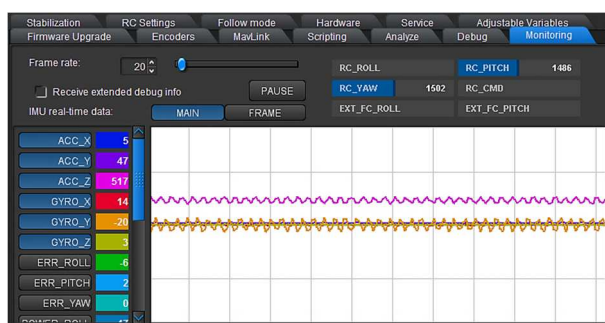
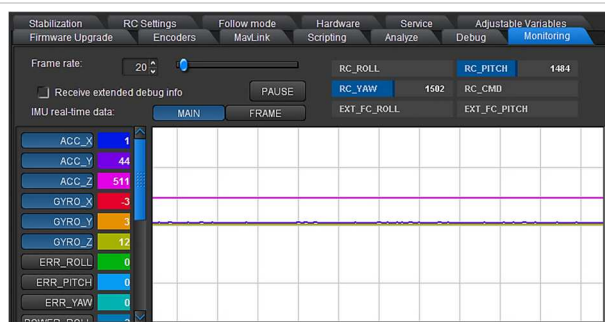

# Using the Software PC/MAC – PID control

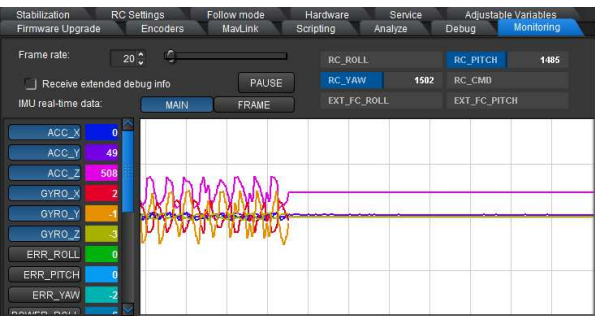
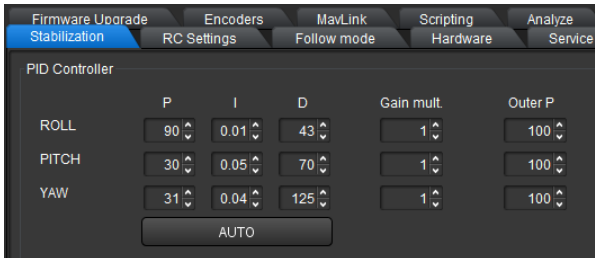
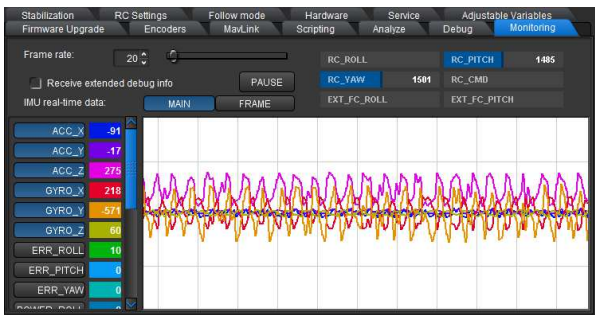
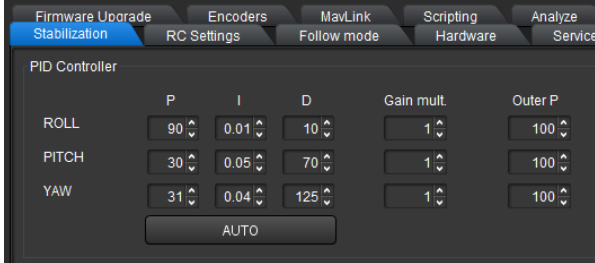

- Gradually increase the P value on the axis to be set. As soon as the axis begins to swing independently (see adjacent illustration of “monitoring”), leave the P value for the moment and increase the D value until the axis no longer swings by itself. Tap lightly on the axis and test whether the axis begins to swing as a result of external stimulus. If yes, increase the D value a little. When you no longer feel or see vibrations, test your result again via the monitoring. To see the finest vibrations, you can zoom in on the diagram in the dialogue window using the slider.
- Repeat step 2 until you can no longer reduce the natural vibrations by increasing the D value. If the D value is too high, it will at some stage during the setting process cause high-frequency vibrations. These can be easily felt and heard. You have now determined the maximum values for P and D.
- Reduce both values again slightly, until you can sense no more wobbling and no vibrations.
- You can now increase the I value gradually. As soon as you determine low-frequency vibrations, reduce the value again, until you can no longer determine vibrations.
- Repeat the steps for the other axes respectively.

# Using the Software PC/MAC – PID control

---

10. After you have optimally set the PID parameter for all axes in a static state, move the Gimbal in all directions, as in later real use. If you can still determine vibrations due to the mutual interaction of the three axes in certain positions, reduce the PID values slightly for the axis that is still disruptive.

Certain resonance vibrations, which can be caused by the interaction between your camera and the mechanical structure of the Gimbal, cannot be reduced as necessary by setting the PID control parameter. Read up under ► 5.13 Use of digital filters (reduce vibrations) - EXPERT



## Note

**Tip!** In the view level “DEVELOPER” it is possible to temporarily disable the axis motors, on which you could not conduct a PID fine-tune, to ensure that they do not irritate with additional vibrations during the process. But ensure that you do not alter other settings in the view level “DEVELOPER”. Note the assigned motor designation before you disable it so that you can then assign it correctly again and reactivate it later.



## Note

**Tip!** Find out which axis is causing the most vibrations. To do this go to the register card “Monitoring” on the user surface (GUI). First select “Receive extended debug info” by marking the check box, so the parameters **FREQ\_ERR** und **RMS\_ERR** can be seen. With **FREQ\_ERR** you will find the interfering frequency. With **RMS\_ERR** you can find out easily the axis, which causes the interfering frequency.



## Note

**Function!** During the adjustment hold the device vertically and in a stable position in your hand, preferably supported by a solid surface (table surface, tripod, etc.).



## Note

**Function!** Before you begin the automatic fine-tuning process with the PID control parameter, ensure that the camera is balanced, the gyrometer and accelerometer are calibrated and the PID gain multiplier is set for all 3 axes to the standard 1.0. The Gimbal has to be completely still and free of vibrations (e.g. tripod), camera horizontally aligned and there should be sufficient freedom of movement that every axis can turn approx. 20-30°.

# Using the Software PC/MAC – PID control

## 5.10.2 Automatically optimize the PID control settings

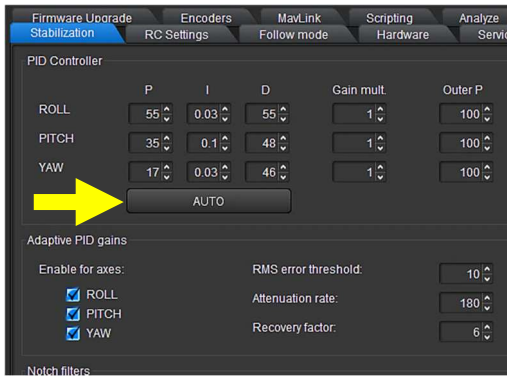

20

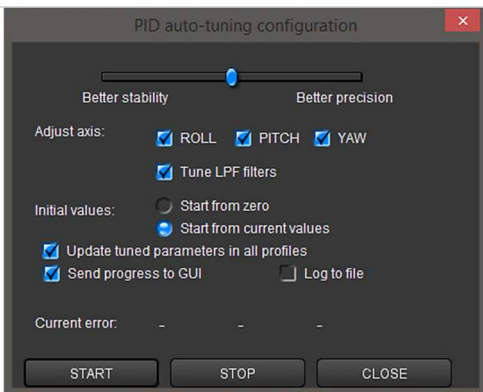

21

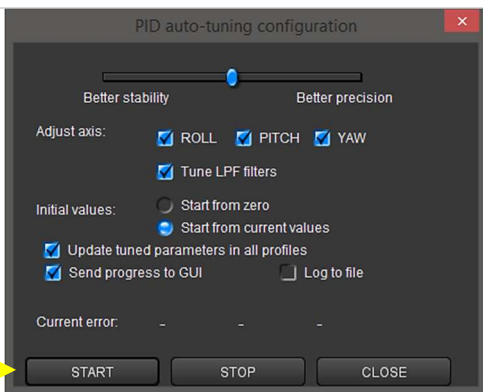

22

11. **Automatically optimize the PID control settings.** Before you start ensure that the Gimbal is stable. For general information on mechanisms of the PID parameter read ▶ 2.5 *Fine-tuning using the SimpleBGC software*

12. Select the setting **Gain = 1** (direct multiplier for the P and D value) and the value for **Outer P = 100** (speed of angle correction, standard setting Outer P = 100) for all three axes.

13. Press the **“AUTO”** button in the function block PID controller in the register “stabilisation”.

14. Mark the axis for which you would like to automatically adjust the PID Settings in the appearing dialogue. You can conduct the process simultaneously for all three axes.

15. Stipulate the priority of your setting using the slider. It will differentiate between an improved quality of stability or a higher level of precision.

16. Mark the box “Tune LPF filters” (possible from Firmware 2.60), to significantly improve the quality of stability for high-frequency resonances in the system.

17. Mark “Start from current values”, so the fine-tuning process starts at the current setting and not from zero!

# Using the Software PC/MAC – PID control

---

18. Mark the remaining check boxes as shown in the adjacent illustration. You can also have the data entered into a log file during the process. This is called “auto\_pid\_log.csv”.
19. Press the “Start” button to begin the automatic fine-tuning process with the PID control parameter.

The process takes approx. **1 minute**.

Certain resonance vibrations, which can be caused by the interaction between your camera and the mechanical structure of the Gimbal, cannot be reduced as necessary by setting the PID control parameter. Read up under ► *5.13 Use of digital filters (Reduce vibrations) - EXPERT*



## Note

**Function!** When you use the Gimbal in an area with extreme temperature differences a calibration of the temperature sensors can be conducted. Generally this will not be necessary. If it is, we would like to refer you to the respective current edition of the instruction manual for SimpleBGC software. Use at your own risk. Observe the safety information.



## Note

**Function!** During the automatic fine-tuning process the control unit sends a command for the camera to rotate on a small angle to find the optimal system data for error minimization. The current error value is shown in the dialogue window. The error value should get consistently smaller during the automatic fine-tuning process. The process is completed when the error can no longer be reduced. You can also cancel the process by pressing the “STOP” button. The current optimized values are saved and displayed. The process is interrupted in an emergency when the system is not stable due to automatically set values. In this case you should press the mode button on the Gimbal to start the system again and to repeat the automatic fine-tuning process from the beginning.



## Note

**Tip!** When you conduct the PID fine-tuning process for the first time, disable the check box “Update tuned parameters in all profiles”. If the automatic settings do not lead to the desired result, not all profiles become unusable. You can produce your profile again via the downloading function from a previously created safeguard.

# Using the Software PC/MAC – Time lapse

## 5.11 Using the time lapse settings – ADVANCED

Your Pilotfly Gimbal supports a time lapse function. You should determine an end point and a starting point for the scenes you wish to capture. The Gimbal then moves the camera at a speed set by you from the starting position to the end point.

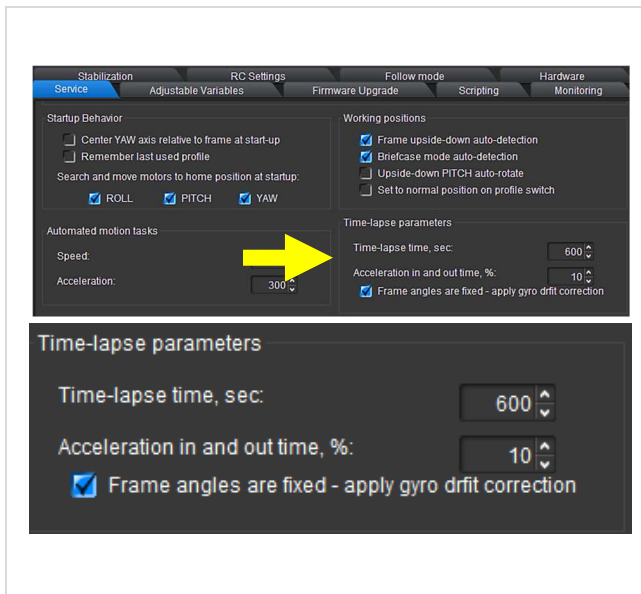

23

1. Select the register “service” and go to the function block “Time lapse parameters”.
2. Enter the time period in seconds, in which the camera should be moved from the starting position to the end point into the “Time lapse time,sec”.
3. You can also determine and select an acceleration value in %, whether you would like to use a gyro drift correction.
4. Save these settings individually for each as a profile.

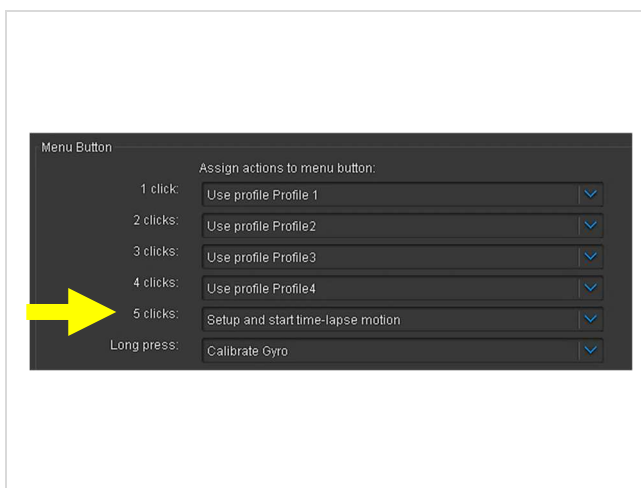

24

5. Stay in the “service” register, load this profile and assign the mode button on your Gimbal, for example as shown in the adjacent illustration, pressing 5x “Setup and start time-lapse motion”. Remark: We recommend to assign this function with “5 clicks”, so that you have the profiles 1 to 4 for different settings of time-lapse time.
6. Press the “WRITE” button, to transfer the settings to your Gimbal.

## Using the Software PC/MAC – Time lapse



25

7. To use the time-lapse function, first select the time duration by pressing the mode button for the profile number 1 to 4, which you have determined yourself for the respective time-lapse time.
8. Now determine the end position **2** for the camera. To do this turn the camera to the last scene you wish to capture.
9. Now activate the time-lapse function by pressing the mode button 5 times.

An acoustic signal will sound for approx. 10 seconds.

10. Within these 10 seconds determine the starting point **1** for the camera. To do this, turn the camera with the joystick or by hand to the first scene you wish to capture.
11. After 10 seconds has elapsed the acoustic signal stops and the time-lapse function starts automatically.

The camera now moves slowly in the time period determined by you from the starting point to the end position.

# Using the Software PC/MAC – Buzzer

## 5.12 BUZZER and LED settings – ADVANCED

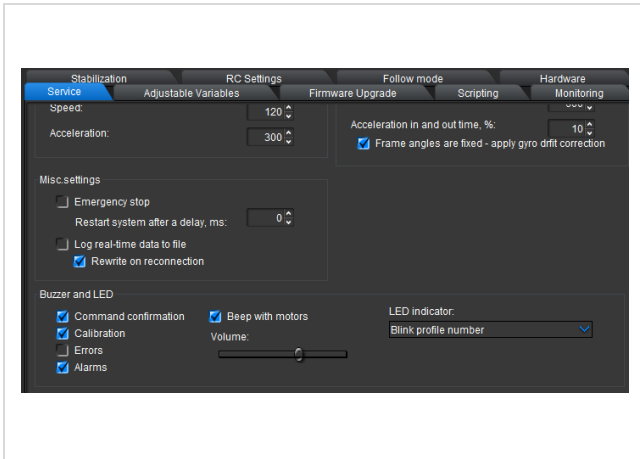

1. Select the register "Service" and go to the functional block „Buzzer and LED“.
2. Here you can set, when the Buzzer should give an acoustic signal and if the Buzzer shall be deactivated completely. Therefore, deactivate the respective check boxes.
3. Press the button "WRITE" to transfer the settings onto your Gimbal.

# Using the Software PC/MAC – Digital Filter

## 5.13 Using the digital filter (reducing resonance) - EXPERT



### Warning

**Risk of injury!** Before you switch on the device, please read the instruction manual in full and familiarize yourself with all operational and safety notes. Follow the information and tips, so you can use the device to its full potential.



### Caution

**Property damage!** Do not change any settings of which you are unsure!

### 5.13.1 Notch filter – Reduce vibrations on certain frequencies

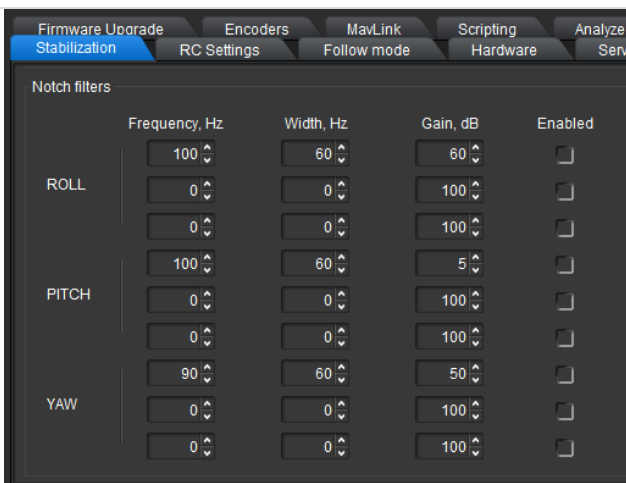

#### Notch Filters:

Under certain conditions the system, which consists of your camera and the Gimbal, can display resonance vibrations, which cannot be reduced using the PID control parameter due to the mechanical structure.

In this function block you can improve the quality of stability further using one or several notch filters, in particular when the system only displays resonance at certain frequencies. You therefore have to attempt to find the applicable frequency.

You can control the effect of the notch filter with the amplifier parameter "Gain,dB". You attain the maximum effect at the setting 100. To compensate for only slight resonances, set the parameter at values lower than 50.

# Using the Software PC/MAC – Digital Filter

## 5.13.2 Low-pass filter – Reduce high-frequency vibrations

Low-pass filters				
	Feedback signal LPF cut-off frequency, Hz	Enabled	D-term LPF cut-off frequency, Hz	Enabled
ROLL	60	<input type="checkbox"/>	90	<input checked="" type="checkbox"/>
PITCH	60	<input checked="" type="checkbox"/>	150	<input checked="" type="checkbox"/>
YAW	60	<input checked="" type="checkbox"/>	60	<input checked="" type="checkbox"/>

**Low pass filters:** In particular when you are using a heavy camera, it can be necessary to dampen any emerging resonances with a low-pass filter.

As the D factor favours the PID control resonances in connection with heavy cameras at high frequencies, a low-pass filter can dampen the amplification of high frequencies and as such improve the stability of the system.

However, a disadvantage is a resulting negative phase delay, which adversely effects the PID stability.

Therefore, it is somewhat complicated to configure this filter and its use is not always justified.

# Using the Software PC/MAC – Digital Filter

---



## Note

### Example for the setting of a notch filter:

*Assuming that the behaviour of the Pilofly C45 with camera is stable, but if the camera is inclined to approx. 60° downwards, strong vibrations occur.*

1. Firstly find out which axis is causing the most vibrations. To do this go to the register card “Monitoring” on the user surface (GUI) and switch on the following graphics: **RMS\_ERR\_R (ROLL-Axis)**, **RMS\_ERR\_P (PITCH-Axis)**, **RMS\_ERR\_Y (YAW-Axis)**. First select “Receive extended debug info” by marking the check box so these parameters can be seen.
2. Tip the camera slowly to the angle where the vibrations begin. The axis at which the vibrations increase the strongest is the primary responsible axis. In this example it is the parameter **RMS\_ERR\_P**, therefore the pitch axis.
3. While you let the Gimbal vibrate further unaltered in this position, observe the frequency display and check other parameters in the same register card: **FREQ\_P**. This displays the main frequency of the vibration (in our case for example 100).
4. Now enter the values for the first notch filter on the pitch axis in the register card “Stabilization”: Frequency 100, width 10, gain: 80 and activate the filter using the check box “enabled”.
5. Transfer the parameter for your Pilofly Gimbal by pressing on the “WRITE” button.
6. Now attempt to provoke the vibrations again. You can now see for example that the vibration at 100 Hz has been reduced significantly but is still there at 105 Hz. Repeat the procedure while changing the frequency parameter to the value 105. You can now see that the vibration has shifted to 95Hz. Therefore reset the frequency to the value 100 and increase the filter range to the value 20. The vibration should now have disappeared completely at the resonance frequency. Set the range as narrow as possible. If the range is too broad it can cause a lower efficiency in PID controlling.
7. After the resonance has been eliminated you can continue the increase of the PID amplification using the parameters P and D. The second resonance now occurs, for example at 140 Hz, when you tilt the camera upwards. Repeat the procedure from step 1 to 6 and enter the parameters for the second notch filter on the pitch axis.

## 6. Using the Android App



### Tip

**Function!** A new version of the Android App is available soon. You can still use the Android application by downgrading the firmware of your Gimbal to version 2.56b9.

Implicitly make a backup of the entire Gimbal settings and save your profiles on a computer before you change the firmware of your Gimbal. Existing data will be deleted ▶▶ 5. *Using the Software PC/MAC* ▶▶ 5.3 *Saving and loading profiles onto the computer* and chapter ▶▶ 5.5 *Making a backup with the backup manager*.



### Warning

**Injury danger!** Before you change any settings, please read the instruction manual completely and get familiar with all use and safety instructions. Follow the notes and tips so that you can use the device optimally.



### Caution

**Property damage!** Do not change any setting if you are not aware of it.



### Tip

**Function!** Although you are able to „RESET“ your Gimbal. **Please do not use the „RESET“ Function otherwise you will delete your default profiles which has been individually set by Pilotfly.**

Please make a backup of each profile and save it to your computer before you change any settings. ▶ 5. *Using the Software PC/MAC*



### Tip

**Legal hint!** Pilotfly is license holder and partner of Basecam electronics and is using their products and software, but is not responsible for any software bug or malfunction of the provided software itself.

### 6.1 Gimbal settings

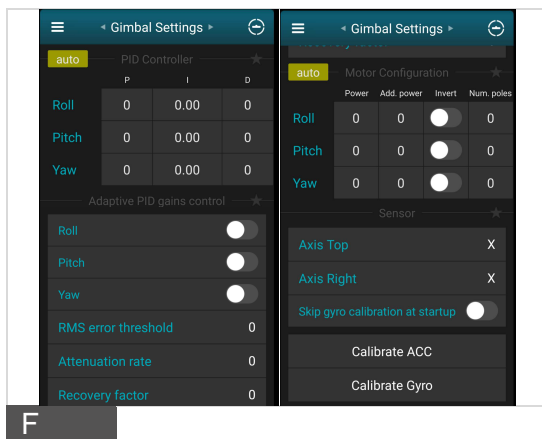

1. Set your PID values and Motor power values  
▶▶ 2.5 *Fine adjustment with help of the Software SimpleBGC*

# Using the Android App

## 6.2 Misc settings

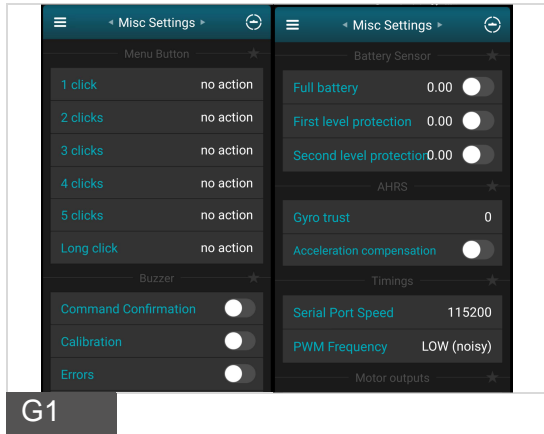

2. In the Misc Settings you are able to change the command of the 4-way-joysticks, change sound commands e.g. for errors or other system hints.

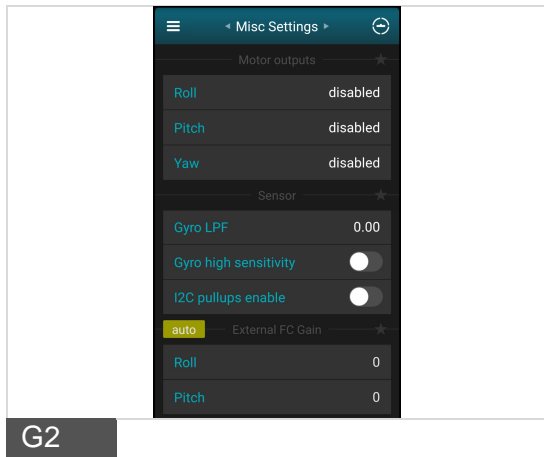

# Using the Android App

## 6.3 RC settings

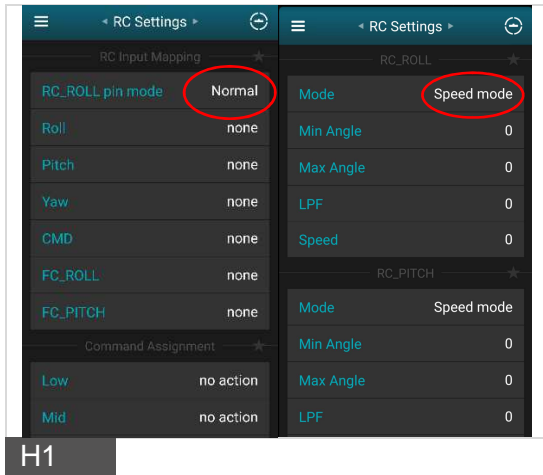

3. In this area you are able to change the settings of the joystick, change speed and angel of moving area.

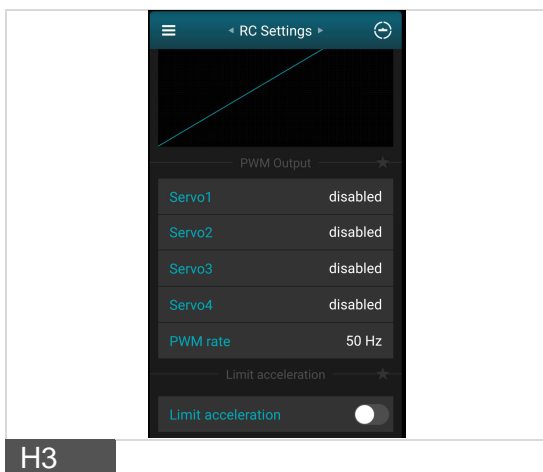
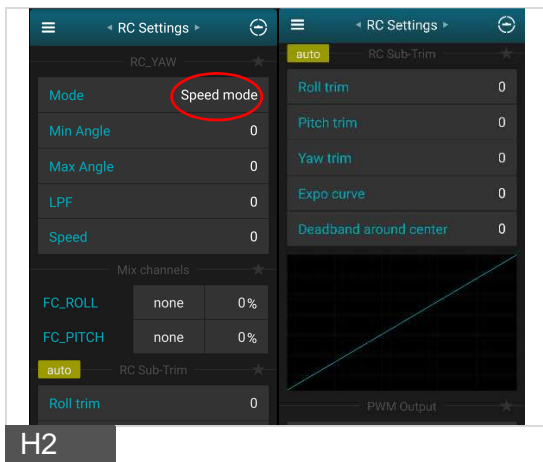

# Using the Android App



## Tip

**Function!** If you are experiencing any malfunction like that you are unable to control the axes, please ensure that all RC Mode for each axis is set to „Speed Mode“ instead of „Angle Mode“.

## 6.4 Follow mode

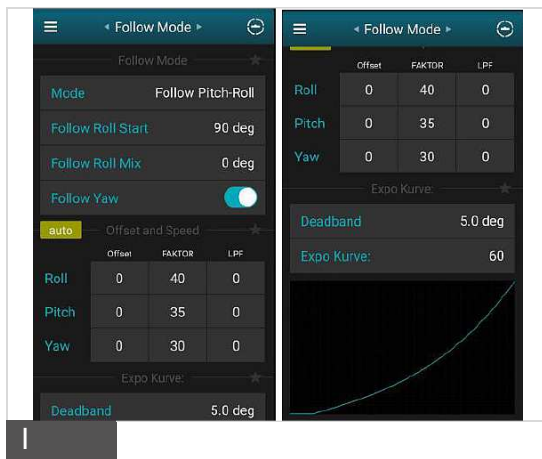

4. The Follow Mode is a special control mode that makes the camera to „follow“ the movements. You are able to change the settings to follow an individual axes or change the speed of the movement (Factor).

## 6.5 Monitoring

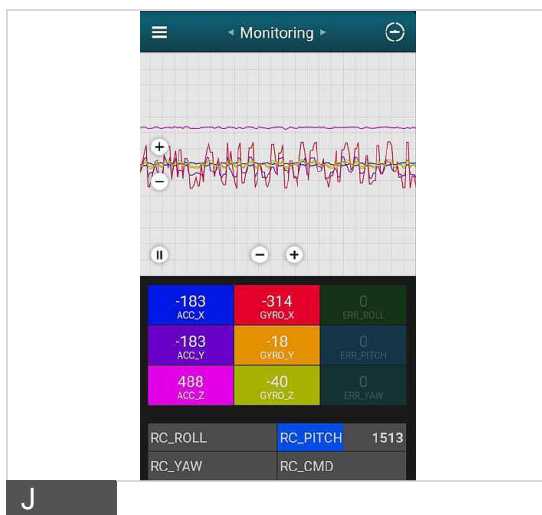

5. In this tab you can see the raw sensor data stream, logical RC input levels and some debug information. The monitor helps you to recognize in a easy and fast way which motor/axis is vibrating.

# Using the Android App

## 6.6 Control

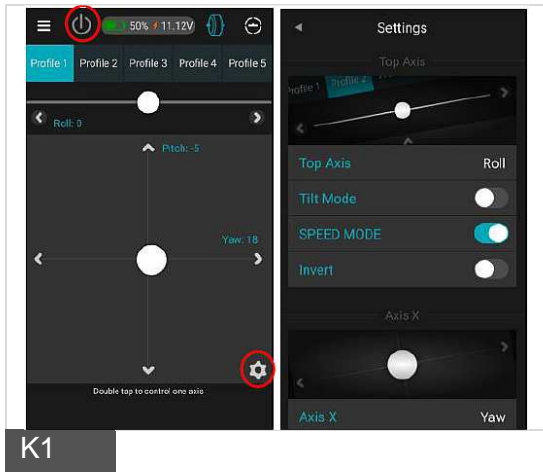

6. The control panel enables you to control each axis while moving the white cursor. In the sub menu „Settings“  you are able to set which axis you want to control on the touch panel or by moving the smartphone (Tilt mode). The touch panel is generally locked and needs to be activated first by pressing the On/Off button on the upper left corner.

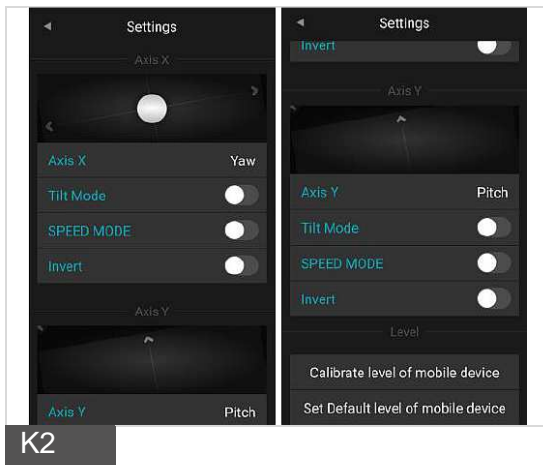

# Using the Android App

---

## 6.7 Settings



Tip

**Function!** Although you are able to „RESET“ your Gimbal. **Please do not use the „RESET“ Function otherwise you will delete your default profiles which has been individually set by Pilotfly.**

Please make a backup of each profile and save it to your computer before you change any settings. ▶ 5. *Using the Software PC/MAC*

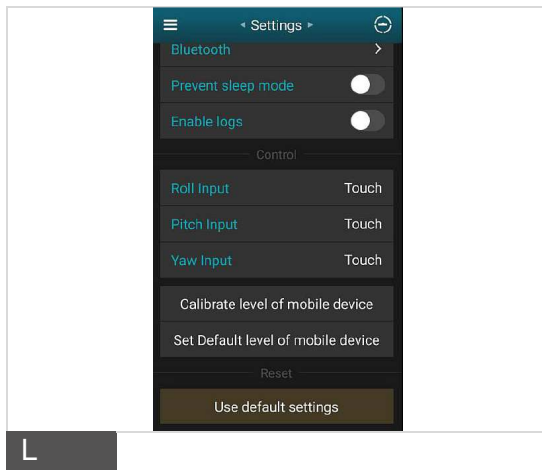

7. In the “Settings” menu you are able to set general settings.

## 7. Failure / Repair

Before you contact the service hotline ► *Pilotfly-Service*, please check by using the following table whether you can solve the problem by yourself.



### Warning

**Injury danger!** Do not carry out any repairs at the device by yourself. Let the repairs at the device or at the cable only carried out by us ► *Pilotfly-Service*. Extensive dangers for the user can arise from improper repairs.

Roll motor is not horizontal levelled	Please make a Gyro & ACC calibration described in the user manual. Watch the video: <a href="https://youtu.be/lxpdztvizoQ">https://youtu.be/lxpdztvizoQ</a>
The system starts vibrating while moving the Gimbal 90° forward (brief case position)	Figure out which motor is causing the vibrations, in this case it is most likely caused by the Pitch motor. If so decrease the D-value of the Pitch slightly or change Motor power value of Pitch.
Pitch motor is suddenly missing steps while moving up or down.	Ensure proper balancing of the camera. Increase motor power of Pitch motor.
System starts vibrating while moving	Figure out which motor is causing the vibrations, and decrease the D-value of the related axes or change Motor power value of related axes.
System is slightly drifting on the yaw axis.	Poor Gyro calibration of Frame IMU. Frame IMU needs to be re-calibrated. <b>Note:</b> Frame IMU must be calibrated via SimpleBGC Software installed on your PC, MAC or Android App ( <a href="#">SimpleBGC32</a> )
While moving forward (brief case position) roll axis keeps not straight and is moving slightly to left or right.	Poor ACC & Gyro calibration of Camera IMU. Please make a Gyro & ACC calibration described in the user manual. Watch the video: <a href="https://youtu.be/lxpdztvizoQ">https://youtu.be/lxpdztvizoQ</a>
Where can I find the serial number of my Gimbal	You can see the serial number in the register "Firmware Upgrade" of the SimpleBGC software.
The Gimbal shows vibrations at the preset	Vibrations can be eliminated with the help of the PID-parametres or the filter setting in the SimpleBGC software.

# Failure / Repair

<p>System is flatter in each direction.</p>	<p>Wrong motor setup. Hold the Gimbal steady and start "Auto" for the Motors in the Basic Tab of SimpleBGC GUI. Ensure that all motor poles are set to "14".</p> <p>After that perform a calibration for Camera and Frame IMU sensors. Video: <a href="https://youtu.be/lxpdztvizoQ">https://youtu.be/lxpdztvizoQ</a></p>
<p>System starts beeping continuously.</p>	<p>Check battery level. Battery might be exhausted. Charge battery or connect the external battery.</p>
<p>System starts beeping and battery is fully charged.</p>	<p>Check battery level in the SimpleBGC GUI on the right bottom corner.</p> <p>Battery calibration might be necessary. Please follow the instruction for <a href="#">battery calibration</a>.</p>
<p>Roll and pitch not in level even after ACC &amp; Gyro calibration</p>	<p>Verify in the RC –Tab of the SimpleBGC GUI the "Initial angle" of each axes. Initial angle need to be set to "0".</p> <p><b>Note:</b> Operations like "Set tilt angles by hands", "Swap RC Roll-Yaw" or "Swap RC Pitch – Roll" will save their angles to this field, too.</p>
<p>The Gimbal cannot be connected over Bluetooth with the SimpleBGC 32 bit Software GUI</p>	<p>Set the the View level on "ADVANCED". Now you will find the option "Configure bluetooth" at the board settings .</p> <p>There you can see the Bluetooth settings for the Bluetooth module.</p> <p>The preset command is "AT". Press the button "SEND". If the answer is OK / OK the cause of the error is not with the Gimbal, but in all probability with the transmitter. Check possible errors with the help of the transmitter-sided instructions for use.</p>
<p>The yaw-axis isn't centered at the start position</p>	<p>Perform an OFFSET-calibration. Center the yaw-axis manually or by means of the joystick. Set the view level to "EXPERT". In the register tab "Encoders" press the button "CALIB. OFFSET".</p> <p>Watch the video:  <a href="https://www.youtube.com/watch?list=PL5Inulln_ZKcWR_SpY-QbBoMWPPuOcXLk&amp;v=XSjvjdD6cto">https://www.youtube.com/watch?list=PL5Inulln_ZKcWR_SpY-QbBoMWPPuOcXLk&amp;v=XSjvjdD6cto</a></p>

## 8. Maintenance and care

---

The device is maintenance-free. In case of a reduction of the accumulator performance you can order a replacement at our service ► *Pilotfly-Service*. Follow especially the safety instructions ► *1. 7 Precautions at handling with Li-Po accumulators!*

Clean the device with a dry antistatic cloth.



### Warning

**Injury danger!** Switch off the device and unplug the plug from the power socket before you clean it.



### Caution

**Property damage!** Never use aggressive cleaning or abrasives.

## 9. Put out of operation, Storage, Transport

---

If you put the device out of operation temporarily, unplug the plug from the power socket and pack the device and its accessories into the accompanying carrier bag.

At a longer removal from service you should charge the device from time to time as described in this instruction manual ► *2. Setup and operating/2.3 First steps*.

Store the device at a cool dry place.

# 10. Service

---

Nevertheless, if you should have problems with your product, please address your enquiry to [pilotflyteam@gmail.com](mailto:pilotflyteam@gmail.com) (Taiwan) or [info@pilotfly.de](mailto:info@pilotfly.de) (Germany). We help you along willingly promptly and give you information about the next steps.

## Service Adresse Taiwan

Pilotfly Technology Co. LTD.  
Jiafeng South Rd. No.118, 2F-2  
Zhubei City, Hsinchu County 30271  
Taiwan

Email: [yanherlin@gmail.com](mailto:yanherlin@gmail.com)

## Service Adresse Germany

Pilotfly GmbH  
Wendelsteinstr.12  
86163 Augsburg  
Deutschland

Email: [marcus.oswald@pilotfly.de](mailto:marcus.oswald@pilotfly.de)

## Further useful links:

You can download the current version of the instruction manual in the support area of our web page: [www.pilotfly.de](http://www.pilotfly.de) or [www.pilotfly.com.tw](http://www.pilotfly.com.tw).

For quick access please use our QR-codes:



Pilotfly Channel / Video tutorial

## Software and driver download:



Pilotfly C45 Folder



SIMPLEBGC GUI



USB Driver

# 11. EU declaration of conformity (DoC)

---

Hereby Pilotfly declares that the Gimbal type C45 and its accessories are in compliance with the relevant harmonisation legislation of the European Union: Directive for radio equipment **2014/53/EU**, RoHS-directive **2011/65/EU** restricting the use of hazardous substances in electrical and electronic equipment as well as ERP-directive **2009/125/EU** concerning energy related products. The full text of the EU declaration of conformity is available at the following internet address: [www.pilotfly.de](http://www.pilotfly.de) or [www.pilotfly.com.tw](http://www.pilotfly.com.tw).

# PILOTFLY C45

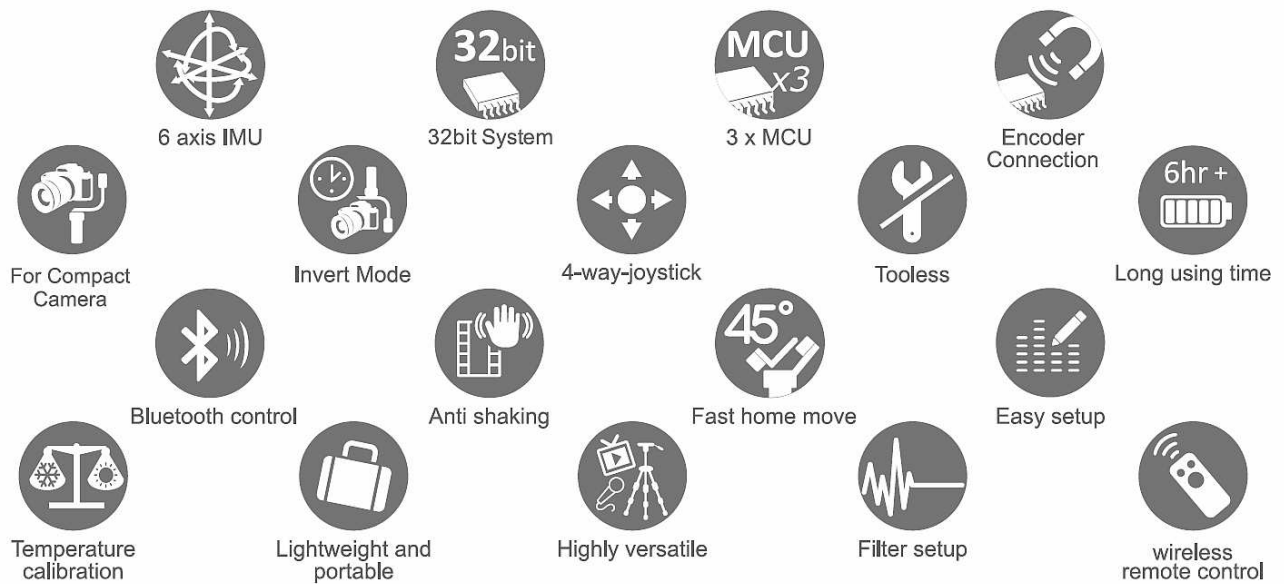

IM\_100.CCF.20170512-EN C45

## Taiwan

**Pilotfly Technology Co., Ltd.**  
2F.-2, No.118, Sec. 1, Jiafeng S. Rd.  
Zhubei City, Hsinchu County 30271  
[www.pilotfly.com.tw](http://www.pilotfly.com.tw)

## Germany

**Pilotfly GmbH**  
Wendelsteinstr.12  
86163 Augsburg  
[www.pilotfly.de](http://www.pilotfly.de)



Technical Support via E-mail:  
[info@pilotfly.de](mailto:info@pilotfly.de) , [pilotflyteam@gmail.com](mailto:pilotflyteam@gmail.com)



Welcome to **PILOTFLY** fans  
<http://www.facebook.com/Pilotflytech>