

Lily NEXT-GEN™
Camera. Drone. Reinvented™

Owner's Manual V1.0.1

For updates please visit www.lily.camera



LILY®



72





CONTENTS

Legend.....1

| | |
|--------------------------|---|
| Reading Suggestions..... | 1 |
| Downloading the App..... | 1 |

Overview.....2

| | |
|--|---|
| Introduction..... | 2 |
| Feature Highlights..... | 2 |
| LILY CAMERA NEXT-GEN DRONE App..... | 2 |
| Visual Positioning..... | 2 |
| High Definition Photo & Video Capture..... | 2 |
| Electronic Image Stabilization (EIS)..... | 2 |
| Object Tracking and Follow Me..... | 2 |
| Orbit (360°)..... | 2 |
| Intelligent Operation..... | 3 |
| One-Touch Sharing..... | 3 |
| Lily Next-Gen-At-A-Glance..... | 3 |

Features.....5

| | |
|--|----|
| On/Off Switch and Power Indicator..... | 5 |
| Drone Status Indicator..... | 5 |
| GPS Positioning..... | 5 |
| Optic Flow and Ultrasonic Positioning..... | 6 |
| Usage Conditions and Restrictions..... | 6 |
| Propellers..... | 6 |
| Battery..... | 8 |
| Camera..... | 11 |
| Signal Frequency..... | 11 |
| Micro-USB Port..... | 11 |
| Reset Button..... | 11 |
| LILY CAMERA NEXT-GEN DRONE App..... | 12 |
| App Overview..... | 12 |
| App Operation Interface..... | 12 |
| 1.Back to main interface..... | 13 |
| 2.Wi-Fi Connection Status..... | 13 |
| 3.Current Flight Distance..... | 13 |
| 4.Current Flight Height..... | 13 |
| 5.Aircraft Battery..... | 13 |
| 6.Positioning Status..... | 14 |
| 7.Status Bar..... | 14 |
| 8.App Settings..... | 14 |
| 9.Object Tracking..... | 14 |
| 10. Orbit (360°)..... | 14 |
| 11.Photo/Video Switch..... | 14 |
| 12.Shutter..... | 15 |
| 13.Camera Settings..... | 15 |
| 14. Media Library..... | 15 |
| 15. Take-off / Landing / Stop..... | 15 |
| 16. Return to Home..... | 15 |
| App Settings..... | 15 |
| Compass Calibration..... | 15 |
| Photograph Vibration..... | 15 |
| App Mute..... | 16 |
| Control Method..... | 16 |

| | |
|---|----|
| Change Wi-Fi Information..... | 16 |
| Lily FC Update..... | 16 |
| Lily OS Update..... | 16 |
| Available Storage..... | 16 |
| Personal Center Settings Quick Guide..... | 16 |
| Malfunction Report..... | 17 |
| Suggestions and Feedback..... | 17 |
| Change Password..... | 17 |
| Language..... | 17 |
| About..... | 17 |
| Media Library..... | 17 |
| Photo Thumbnails..... | 17 |
| Selecting Photos..... | 18 |
| Deleting Photos..... | 18 |
| Downloading & Browsing..... | 18 |
| Photo Sharing..... | 18 |
| Videos..... | 19 |

Flying/Shooting.....20

| | |
|--|----|
| Flight Environment Requirements..... | 20 |
| Outdoors..... | 20 |
| Indoors..... | 20 |
| Flight Restrictions..... | 20 |
| No-Fly Zones..... | 21 |
| Preflight Checklist..... | 21 |
| Calibrating the Compass..... | 21 |
| Flight Protections..... | 22 |
| Connecting Your Lily to a Mobile Device..... | 22 |
| Take-off / Landing..... | 23 |
| Flight Control..... | 23 |
| Motion Sensing..... | 23 |
| Free Sticks..... | 24 |
| Safe Sticks..... | 26 |
| Taking Photos/Video Recording..... | 26 |
| Taking Photos..... | 26 |
| Electronic Image Stabilization..... | 26 |
| Orbit (360°)..... | 27 |
| Object Tracking..... | 30 |
| Return to Home..... | 31 |

Warranty Card.....33

| | |
|---------------------------|----|
| Purchase Information..... | 33 |
| Maintenance Records..... | 33 |

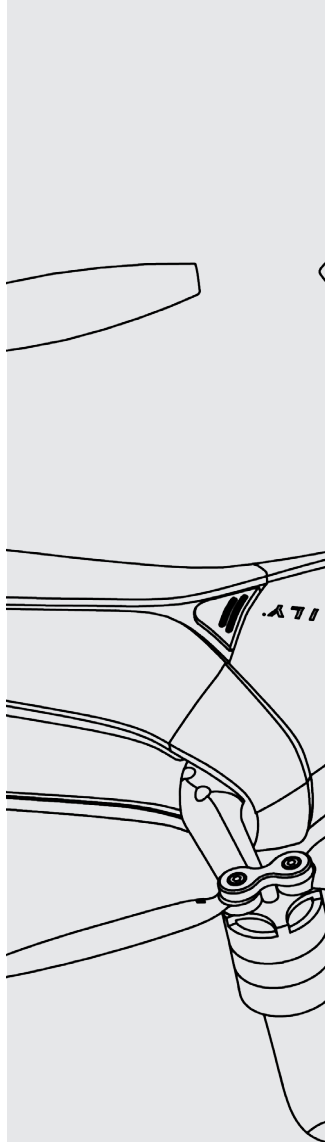

Legend

Symbols



Warning



Tips

Reading Suggestions

We have provided the following materials for Lily Next-Gen users. To learn how to get the most use out of your Lily Next-Gen, we suggest you read them in this order:

1. Battery Safety Instructions / Disclaimer
2. Quick Start Guide
3. Owner's Manual

Downloading the App

Before using this product, you need to download and install the Lily app. You can scan the following QR code, or search for Lily in the App Store or Google Play, or login and download from the Lily website.



Lily Next-Gen supports Android 4.3 and later versions, iOS 8.4 and later versions.

Overview

This section will introduce Lily's features and the names of Lily's principal components.

Introduction

Lily is a portable and easy-to-use drone for entertainment. It consists of the aircraft itself and an accompanying app.

Through using the app, you can control Lily's flight, take photos and record videos.

Feature Highlights

In order to give you a convenient and safe flying and photographing experience, Lily has several great features:

LILY CAMERA NEXT-GEN DRONE App

The app is specifically developed for Lily and is simple to use. It can be used as a remote control for flight control and for photo & video shooting.

Visual Positioning

Lily uses both optic flow and ultrasonic positioning to support flight when there is no or a weak GPS signal such as indoors. Please install the propeller guard when flying indoors.

High Definition Photo & Video Capture

Lily is equipped with a professional high-definition camera, the SONY IMX 214, 13MP. It features 4K and

1920 x 1080 video shooting.

Electronic Image Stabilization (EIS)

Lily is equipped with electronic image stabilization (EIS), which reduces or eliminates vibration in images. With EIS, photos are saved to the built-in memory with a resolution up to 2880 x 1620 at 96 dpi / 24 bit depth. Videos are stabilized at a resolution of 1920 x 1080p at 30 fps. EIS may be switched off.

Object Tracking and Follow Me

Using advanced image recognition technology, Lily can follow and record video on a moving object you've chosen.

Orbit (360°)

Automatically fly and record video around a stationary point at a specified altitude and radius.

Intelligent Operation

When flying outdoors, the LILY CAMERA NEXT-GEN DRONE app supports multiple one-touch flight operations with just one tap on the screen., such as One-Touch Takeoff, One-Touch Landing, and One-Touch Return.

One-Touch Sharing

Directly share your photos and videos with your friends on SNS.

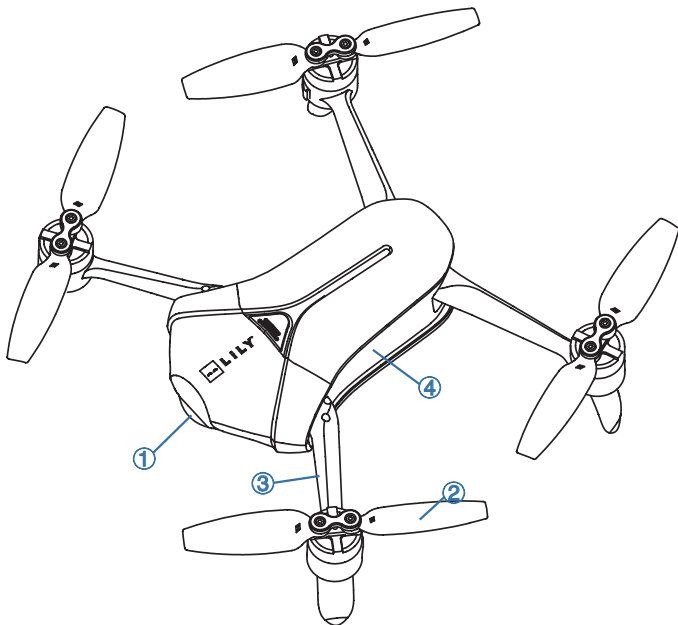

Lily Next-Gen At-a-Glance

- ① Camera
- ② Propeller
- ③ Arm
- ④ Battery compartment

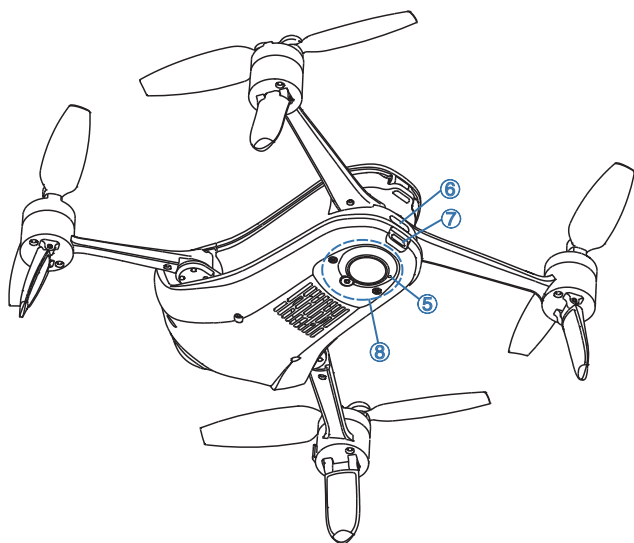

- ⑤ Reset Button
- ⑥ Power Button, Indicator Light
- ⑦ Micro USB port
- ⑧ Optic Flow and Ultrasonic Positioning Module

Features

Lily principally consists of five systems: flight, positioning, communications, power supply and the camera system. This section will explain the functions of each.

On/Off Switch and Power Indicator

The On/Off Switch has a built in Power Indicator.













Hold the On/Off Switch for 3 seconds. Wait until the Power Indicator shows solid green, then remove your finger and Lily will switch on. After a few seconds, Lily will sound, alerting you that the ESC has turned on.

After connecting to the app, the Power Indicator will flash green.

Hold the On/Off Switch for 3 seconds. Wait until the blue light of the Power Indicator goes out, then remove your finger and Lily will switch off.

Drone Status Indicator

On the tail of the aircraft, there's an RGB indicator that shows the status of Lily. The Status Indicator's colors and corresponding meanings are as follows:

| INDICATOR | COLOR | MEANING |
|---|-----------------------------|---|
| Normal Status | | |
|  | Slow Green Flashing | Normal Status |
|  | Green Double Flash | Optical Flow and Ultrasonic Positioning |
| Assistant Prompts | | |
|  | Solid Light Blue | Horizontal Compass Calibration successful |
|  | Light Blue Double Flash | Horizontal Compass Calibration not successful |
|  | Solid Blue | Vertical Compass Calibration successful |
|  | Blue Double Flash | Vertical Compass Calibration not successful |
|  | Solid Blue for 3s | Hold And Power Off |
| Warning And Abnormal Status | | |
|  | Red Double Flash | Critical Battery Warning |
|  | Slow Red Flashing | Low Battery Warning |
|  | Solid Red | No-Fly Zone Warning |
|  | Light off | GPS Failure |
|  | Red-Blue Alternate Flashing | Other Failure |

GPS Positioning

Lily uses a GPS & GLONASS dual-mode satellite positioning system. The satellite positioning system is GPS based, with GLONASS acting as a supplementary system.

During outdoor flights, Lily uses GPS positioning when the number of identified satellites ≥ 8 .

Optic Flow and Ultrasonic Positioning

Lily will use the optic flow and ultrasonic positioning during indoor flight. If the GPS signal is weak (the number of identified satellites is <8) during outdoor flight, the drone will automatically use optic flow and ultrasonic positioning as supplements.

Usage Conditions and Restrictions

The optic flow and ultrasonic positioning system are used for indoor flight. It is also used for outdoor flight if the GPS signal is weak. The operating height range for optic flow and ultrasonic positioning is 0.5-3m.

When using this positioning system, after the drone has taken off and ascended to 0.5m, it will determine if the requirements for using this system have been met. If they have not, it will initiate landing. If the requirements are not met for this system during flight, the drone will initiate landing.

Requirements for the optic flow and ultrasonic positioning system: When using this system, the area underneath the aircraft needs to have a clear textured surface.



The optic flow and ultrasonic positioning system may not work under these circumstances, so please use with caution:

- ⊙ Above highly reflective surfaces;
- ⊙ Above water or transparent objects;
- ⊙ Above people or moving objects;
- ⊙ In areas with rapidly changing/flashing lights;
- ⊙ Above very bright or very dark surfaces;
- ⊙ Above objects that easily absorb ultrasonic waves;
- ⊙ Above surfaces without clear textures or with too sparse or too dense textures;
- ⊙ During fast flight at low levels (0.5m or less)



- ⊙ Ensure that the lens of the optic flow camera is clear.
- ⊙ Because the ultrasonic positioning system may be affected by ultrasonic waves emitted by other ultrasonic equipment, please do not fly near other ultrasonic equipment, including other drones.
- ⊙ The ultrasonic sensor will emit ultrasonic waves that are inaudible to humans but may make some animals nervous. Please do not use the drone close to animals.

Propellers

Lily has 4 sets of foldable propellers. The propellers are already mounted; users need only to expand the arms before the flight. When you're done with flying, fold the arms and the blades to prevent damaging them.

The blades have either "H" or "G" on the top to indicate in which direction they spin, as shown in the following figure:

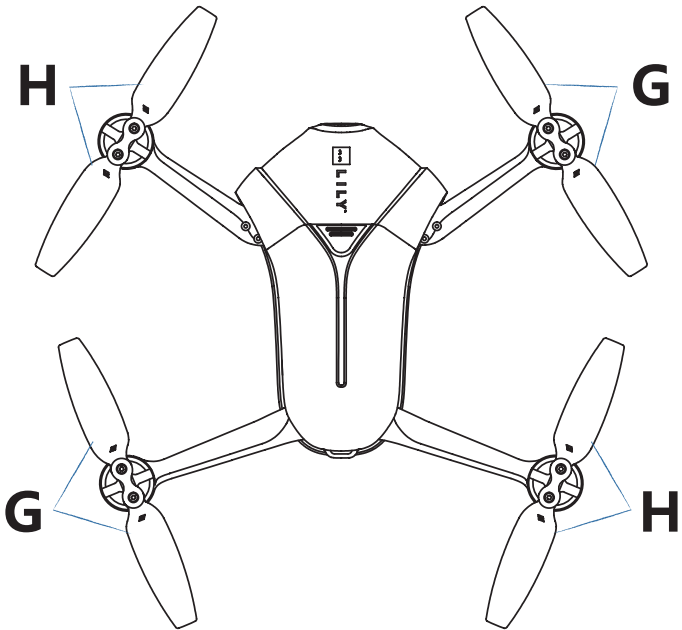

Replacing the Propellers

The propellers must be replaced with ones that spin in the same direction. Propeller blades with an "H" on top must be replaced with ones that also have an "H". Blades with a "G" on top must be replaced with ones that also have a "G", as in the above figure.

How to replace propeller blades:

Use a wrench or a screwdriver to loosen the screws, remove the old ones and mount the new ones onto the base, as shown in the following figure:

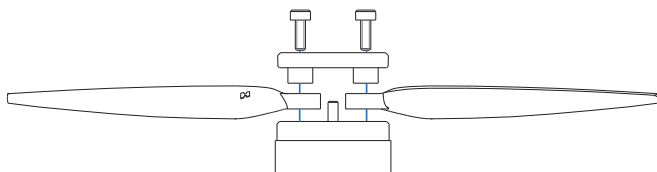

Please ensure that the propeller is tightly screwed in, to prevent the screws coming loose and the blades coming off during flight. They need to be re-tightened after every 10 hours of flight.

Battery

The battery is designed specifically for use with Lily Next-Gen. It has a rated capacity of 1650mAh and a nominal voltage of 11.4V.

Using the Battery

Please insert the battery into the battery compartment before using Lily.



- ⊙ Please don't remove the battery while the aircraft is turned on.
- ⊙ Battery overheating may affect the performance of the drone. Do not use it in hot environments (over 40°C / 104°F).
 - ⊙ If the battery leaks, emits an odor, generates heat by itself, changes shape (swells, etc.), changes color or shows any other abnormalities during use, charging or storage, please remove the battery immediately and dispose of it safely.
 - ⊙ Do not use the battery in cold environments (under 5°C / 41°F), or it may cause irreversible damage. When the temperature is low, the battery's usage time may drop. Please warm it up to 5°C or higher before plugging it into the aircraft, 20°C / 68°F or higher is better.

Charging the Battery

The battery comes with a charger, an adapter, and a USB cable .

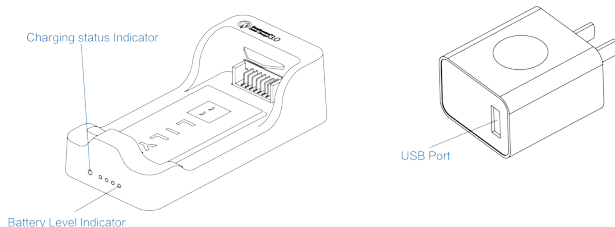

The battery charger's features include:

- ◎ Balance Charging Protection: Automatic balancing of the battery's internal cell voltage to preserve the battery;
- ◎ Overcharge Protection: Overcharging can seriously damage the battery. The battery will stop charging once it's charged to 13.05V;
- ◎ Battery Fault Testing: Stops charging if the test finds an internal battery fault, overheating and or other fault, warning you with flashing red light.

Put the battery into the battery charger, the indicator will show the current battery level and go out automatically after 5 seconds. The indicator's status and the corresponding battery level in percentage are shown as follows:

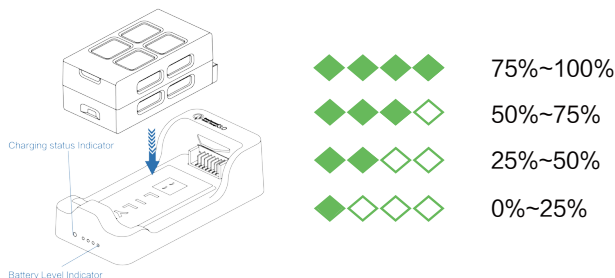

Place the battery into the battery charger. The indicator will show the current battery level and go out automatically after 5 seconds. The indicator's status and the corresponding battery level in percentage are shown.

Use the USB cable to connect the charger to the adapter. Plug the adapter into a power source to begin charging.

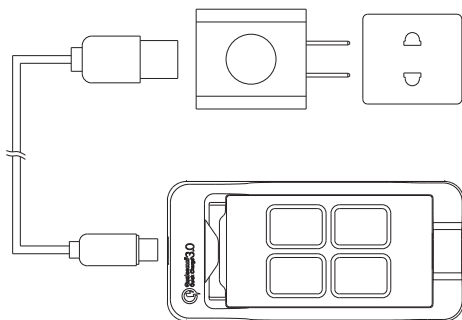

The charger uses Qualcomm Quick Charge 3.0 technology. Using it together with the accompanying adapter allows for quick charges. The Charging Status Indicator will fast flash green during the quick charge. If you don't use the provided adapter, it may perform only a slow charge instead. The Charging Status Indicator will slow flash orange during a slow charge.

If the Charging Status Indicator turns solid green, this means the battery is fully charged. Please turn off the power source and remove the battery from the charger.

The Charging Status Indicator's status and the corresponding meanings are shown as follows:

| Indicator | Color | Meaning |
|-----------|--|--------------------|
| ◇ ◇ ◇ ◇ ◇ | No Display | Not Charging |
| ◇ ◆ ◆ ◆ ◆ | Small Light Show Battery For 5 Minutes | Full Battery |
| ◆ ◆ ◆ ◆ ◆ | Solid Green(Both) | Charging Completed |
| ◆ ◆ ◆ ◆ ◇ | Fast Green Flashing | Fast Charging |
| ◆ ◆ ◆ ◆ ◇ | Slow Orange Flashing | Slow Charging |
| ◆ ◆ ◆ ◆ ◇ | Fast Red Flashing | Failure |



ⓘ We suggest you use the provided Lily battery charger devices to charge the battery. Any issues that occur due to use of other charging equipment shall be the responsibility of the user.

ⓘ Do not charge batteries in the aircraft by connecting Micro-USB to a power source. Damage by so doing is the responsibility of the user.



- ⊙ Users can use a power bank or a car charger to charge the battery. Insert the battery into the charger, and use the USB cable to connect the charger to the power bank or car charger to begin charging.
- ⊙ The adapter can only be used below 2000m above sea level.

Camera

Lily is equipped with a professional high definition camera- SONY IMX 214,13MP, that supports 4K and 1920x1080 video shooting.

Lily is equipped with electronic image stabilization (EIS), which reduces or eliminates vibration in images. With EIS, photos are saved to the built-in memory with a resolution up to 2880 x 1620 at 96 dpi / 24 bit depth. Videos are stabilized at a resolution of 1920 x 1080p at 30 fps. EIS may be switched off.

Signal Frequency

The drone uses 5.8GHz. Different versions may connect with a mobile device at different frequencies. Please check the aircraft frequency from the package.

Micro-USB Port

While Lily is turned on, use the provided USB cable to connect Lily to your computer. You can then copy your photos and videos onto your computer.



- ⊙ Lily must be turned on to be able to connect to your computer.
- ⊙ Lily's Micro-USB port can only be connected to data communication ports, do not connect it to power sources like power banks.

Reset Button

To reset the Wi-Fi, default SSID and password, hold down the Reset Button on the base of the drone for 3 seconds until the Aircraft Status Indicator finishes blue:

- SSID : LILY-NGXXXXXX.
(Labeled beside the battery compartment on the base of the aircraft, the XXXXXX is THE LAST 6 alphanumeric digits of the Wi-Fi's MAC address)
- Password : **lilydrone** (all lower case)

LILY CAMERA NEXT-GEN DRONE App

This section will cover the main sections of the LILY CAMERA NEXT-GEN DRONE app and the settings.

App Overview

LILY CAMERA NEXT-GEN DRONE is specifically developed to be used with Lily. Users can use the app as a remote controller for flight control and photo and video shooting. You can also directly share your photos and videos to social networks.

App Operation Interface

All the key status indicators and main function buttons are shown on the operation interface.

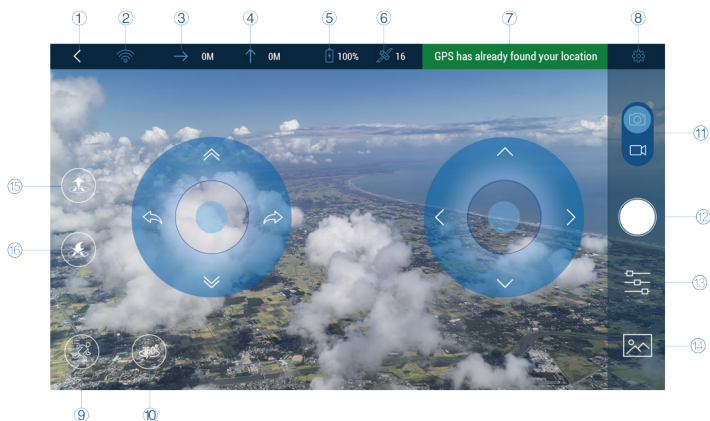

The layout is as follows:

| | |
|----------------------------|-------------------------|
| 1.Back to main interface | 9.Object Tracking |
| 2.Wi-Fi Connection Status | 10.Orbit |
| 3. Current Flight Distance | 11.Photo/Video Switch |
| 4.Current Flight Height | 12.Shutter |
| 5.Aircraft Battery | 13.Camera Setting |
| 6.Positioning Status | 14.Media Library |
| 7.Status Bar | 15.Takeoff/Landing/Stop |
| 8.APP Settings | 16.Return to Home |

Here's a brief description of these status indicators and function buttons. For more details on flight-control and camera operation, please refer to "Flight/Shooting" on page 23.

1.Back to main interface



Return back to the main interface after clicking it.

2. Wi-Fi Connection Status



Wi-Fi connected



Wi-Fi disconnected



If the Wi-Fi connection is lost during flight, Lily will return and land if the GPS positioning is being used or initiate landing if the optic flow and ultrasonic positioning are being used.

3.Current Flight Distance



The current flight distance will be displayed after the icon.

4.Current Flight Height



The current flight height will be displayed after the icon

5.Aircraft Battery



Full battery (The battery level is displayed as a percentage)



Low battery (The battery level will be displayed as a percentage)



If the battery level gets critically low during flight, Lily will initiate landing.



- A full charged battery will provide up to 18 minutes of flight time.
- Flight time depends on environmental conditions, battery condition, and how the drone is flown.
- Please plan your shooting progress according to the current battery level, and charge the battery as needed

6.Positioning Status



GPS positioning status normal (The number of acquired satellites is displayed after the icon. The number ≥ 8 means normal)



GPS positioning status abnormal (The number of acquired satellites is displayed after the icon. The number < 8 means abnormal)



Optic flow and ultrasonic positioning status normal



Optic flow and ultrasonic positioning status abnormal



If the positioning status becomes abnormal during flight, Lily will start to hover until the positioning status returns to normal or user lands it.

7.Status Bar

The status bar will display the current status information. Different levels of status will be displayed in different colors; red-abnormal status, yellow-status warning, blue-normal status. Abnormal status will be displayed by priority if there are several pieces of status information. Tap to see the fault status information.

8.App Settings



Tap to enter the app setting.

Some of the settings will need access to the Internet by using mobile data or switching to router Wi-Fi.

9.Object Tracking



Automatically follows the chosen object and records video.

10. Orbit (360°)



Automatically flies around the chosen target and records video.

11.Photo/Video Switch



Toggle to switch between the main interface and the conventional video recording interface.

12.Shutter



Tap to take photo(s)/ start a video(s)

13.Camera Settings



Tap to enter the camera settings:

Modes



Single shot: Tap to enter the single shot mode



Burst shot: Tap to enter the burst shot mode and select how many photos to Lily.

Parameters

AWB: Tap to set the white balance

EV: Tap to select the exposure value

14.Media Library



Tap to enter your media library.

15.Take-off / Landing / Stop



Tap to initiate take-off.



Tap to initiate landing.



Tap to stop during take-off / landing.

16.Return to Home



Drone automatically returns to its take-off point and lands.

App Settings Compass Calibration

LILY CAMERA NEXT-GEN DRONE will assist compass calibration. Details please refer to "Compass Calibration" on Page 21.

Photograph Vibration

It's turned off by default. When it is activated, your mobile device will vibrate after taking a photo.

App Mute

It's turned off by default. When it is activated, your mobile device will be muted when the app is used.

Control Method

It's set to "Safe Sticks" by default.

There are 3 control methods which users can select: **"Motion Sensing"**, **"Free Sticks"** and **"Safe Sticks"**.

Motion Sensing uses your mobile device's gravity sensor. It allows you to control Lily's flight by tilting your mobile device. For specifics on operation, please refer to "Motion Sensing" on page 23.

Free Sticks allows you to control Lily's flight by using virtual sticks and toggling up/down/left/right. For specifics on operation, please refer to "Free Sticks" on page 24. **You can choose between "Mode 1"(right-hand throttle) and "Mode 2" (left-hand throttle).** Safe Sticks allows you to control Lily's flight by tapping on the arrows on the four directions in the virtual sticks. For specifics on operation, please refer to "Safe Sticks" on page 26. **You can choose between "Mode 1"(right-hand throttle) and "Mode 2" (left-hand throttle).**

Change Wi-Fi Information

You can change the Wi-Fi's SSID and password. The SSID can be up to 16 characters. The password has to be between 8-20 characters long and can be made up of numbers, letters and/or special characters.

Lily FC Update

Upgrade the drone's flight control through the app.

Lily OS Update

Upgrade the drone's operating system through app.

Available Storage

Check the available storage space on Lily. Please plan your shooting according to the available storage space.

Personal Center Settings Quick Guide

Download Lily Quick Start Guide for a quick overview.

Malfunction Report

Please describe the fault information, so that we may investigate and reply back to you.

Suggestions and Feedback

Please enter your feedback to help us improve software releases for your drone as well as future product development.

Change Password

You can change your personal login password(not the drone's Wi-Fi connection password)

Language

Choose your preferred language.

About

Lily Website, User Agreement, etc.

Media Library

When opening the media library, it will go to the photo gallery by default. Tap the "Video" button at the top of the screen to switch to the video gallery.

Photo Thumbnailss

When you are connected to Lily's Wi-Fi after you take photos, the thumbnails will automatically be sent to your mobile device. The photo gallery displays thumbnails in date order. Swipe up to load more thumbnails and swipe down to load new thumbnails.

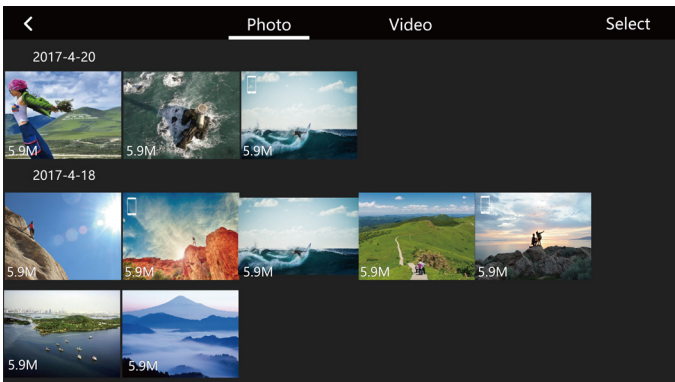

If a photo is already downloaded to your mobile device, a mobile phone icon will be added to the top right-hand corner of the thumbnail .

Selecting Photos

Tap the photo to select. To select all the photos Lily took in one day, tap the "Select All" next to the date.

Deleting Photos

After selecting photos, tap the "Delete" button in the upper right-hand corner of the screen to remove them from your media library. When you are connected to Lily's Wi-Fi, it will delete the files from Lily. When the Wi-Fi is not connected, it will not delete the files from Lily. The browsing page also has a "Delete" button, so you can delete photos directly.



When an Android device is connected to Lily's Wi-Fi, it will ask you to choose to delete from the mobile device or from Lily.
Some Android devices do not yet you undelete photos.

Downloading & Browsing

After selecting photos, tap the "Download" button at the bottom of the screen to download them to your mobile device. You can also download and browse a photo by tapping on the thumbnail. You can directly download and browse the previous/next photo by swiping left/right on the photo browsing page. Tapping on a photo will display it in full screen.



If you have an iOS device, allow access to your gallery in system settings, otherwise, you will only be able to tap the "Download" button in the top right-hand corner to download photos to your gallery. Other downloading methods will download photos into a new folder and you won't be able to download photos to your gallery.

Photo Sharing

There is a "Share" button on the browsing page, tapping it will directly share your photos to your SNS.



Sharing photos needs internet access either by mobile data or Wi-Fi.

Videos

Browsing through videos is basically the same as browsing through photos, but to download videos to your mobile device you need to tap the "Download" button on the top right-hand corner after selecting them. There will be a progress bar during the download. You can download multiple videos at the same time. You can also background download. There's a "Share" button on both the video gallery page and the playing page. You can share your videos directly with your friends on SNS.



iOS mobile device users, please allow access to your gallery in system settings, otherwise, you will only be able to download videos into a new folder and not into your gallery.

Flying/Shooting

Before flying please read Disclaimer and Battery Safety Instructions. This section will cover how to prepare your drone before flight, as well as details on flight and photo & video shooting operations.

Flight Environment Requirements



We suggest you conduct your first flight in an open outdoor area. You may turn off the novice mode after getting familiar with the flight controls.

Outdoors

1. Don't fly Lily in bad weather conditions, such as in gusts, rain, snow.
 2. When flying, always keep Lily in your line of sight. Ensure that you avoid obstacles, high voltage wires, trees and shrubbery, groups of people, bodies of water.
 3. Please fly in an open area, do not fly near buildings and keep a good distance from tall buildings, as the GPS signal may be blocked.
 4. Do not fly near complex electromagnetic environments, such as near a signal tower or base station, as the Wi-Fi signal may be blocked.
 5. Do not fly near areas with abnormal magnetic fields, as the compass may be inaccurate. Lily cannot fly near the North and South Poles.
 6. Flight height should be less than 120 meters, it shall be the responsibility of the user if flight height is over 120 meters.
 7. In areas 3000m or higher above sea level, the flight performance may be affected due to environmental conditions. Please use with caution.
- If the GPS signal is weak, Lily will use the optic flow and ultrasonic positioning. Please fulfill the requirements for the optic flow and ultrasonic positioning, see "Usage Conditions and Restrictions".

Indoors

1. During the indoor flight, Lily uses the optic flow and ultrasonic positioning. The flight area needs to be above a clear textured surface.
2. Indoor flight needs to be conducted in a well-lit area (luminosity > 15lux).
3. During fast flight at low levels (0.5m or less), the optic flow and ultrasonic positioning system may not work.

Flight Restrictions

- ⦿ Maximum ascent height under the GPS positioning: 120m.
- ⦿ Maximum ascent height under the optic flow and ultrasonic positioning: 3m.

© Maximum control distance: 120m (in open air free of interference).

No-Fly Zones

Please do not fly in areas where flying is restricted.

Many areas near airports are no-fly zones.

In no-fly zones, Lily will not be able to fly while using the GPS positioning. The Aircraft Status Indicator will be show yellow flashing. The app will alert you that you are near a no-fly zone.

Preflight Checklist

Please check the following items before flying. You can take off only if all of these items are OK:

1. Your Lily and your mobile device have enough power;
2. The drone's arms are fully expanded;
3. The propellers and other parts of the aircraft are not loose or damaged;
4. The lenses on both the optic flow camera and the front facing camera are clean..

Calibrating the Compass

Lily relies on the compass to determine its heading.

The compass is easily interfered with by other magnetic materials and electronic devices. This can lead to data inaccuracies, and unsafe flight. Also the on-site magnetic field condition also affects the accuracy of the compass. So, regular calibrations before flight help the compass to work at its best.



You're required to calibrate your compass in the following cases:

- © Before the first flight, and before the first outdoor flight;
- © If the location you are flying is quite far from the last location you flew;
- © The Aircraft Status Indicator shows fast purple flashing, indicating compass failure;
- © The Aircraft drifts severely, for example: cannot fly straight.

Expand the arms before calibrating, so as to avoid interference.

Do not calibrate your compass near large metal objects or in places with strong magnetic field interferences.

Do not calibrate your compass near large metal objects or in places with strong magnetic field interferences.

Do not place Lily close to other magnetic materials and electronic devices (such as magnets, mobile phones, tablet PC and stereo equipment).

The process of compass calibration is as follows:

1. Expand the Arms. Turn on the aircraft. Connect to the aircraft's Wi-Fi. Enter LILY CAMERA NEXT-GEN DRONE app "Settings" - "Compass Calibration", and tap on "Start".

2. Keep the aircraft horizontal (the Aircraft Status Indicator will turn solid green if it's set to the required angle). Slowly rotate it 2-3 times. During this rotation, make sure the indicator stays

solid green, which means calibration goes well. Or you will need to adjust the aircraft's angle once again. The app will automatically jump to the next step once it's done.

3. Keep the aircraft head downwards vertically (the Aircraft Status Indicator will turn solid white if it's set to the required angle). Slowly rotate it 2-3 times. During this rotation, make sure the indicator stays solid white, which means calibration goes well. Or you will need to adjust the aircraft's angle once again.

4. The app will notify you once the calibration is completed. At this point, the Aircraft Status Indicator will show the aircraft's actual status.



- ⊙ After the horizontal calibration, immediately begin the vertical calibration, don't stop midway.
- ⊙ The calibration will Lily effective immediately (no need to restart the aircraft).

Flight Protections

In order to ensure safe use and to avoid damage, we have fitted Lily with multiple flight protection measures:



- ⊙ If the battery level gets too low or a major failure occurs, Lily will immediately initiate landing.
- ⊙ If both the GPS and the optic flow and ultrasonic positioning systems are not working, Lily will start to hover until the positioning status returns to normal or user lands it. But if the battery level gets too low while hovering, Lily will initiate landing.
- ⊙ If the Wi-Fi connection is lost or the app drops out, Lily will return and land if the GPS positioning is being used, or initiate landing.
- ⊙ If the optic flow and ultrasonic positioning are being used.
- ⊙ When the app is minimized or you get a phone call, Lily will start to hover until you are back to the app. But if the battery level gets too low while hovering, Lily will initiate landing.
- ⊙ When flying indoor or outdoor where are crowds of people, please add propeller protector for aircraft.

Connecting Lily to a Mobile Device

The default SSID(Wi-Fi name) is like LILY- NGXXXXXX. Click to connect this SSID, and input the default password: lilydrone. You can change them in "App Settings".

Check that the drone is connected to Wi-Fi, that its battery level is full, and that the optic flow positioning and the GPS positioning status are normal. If so, it's ready to fly.



- ⦿ When flying, keep Lily in your line of sight. Please ensure you keep Lily a good distance away from people.
- ⦿ Take extra care not to run into people or objects during indoor flight.

Take-off / Landing

Take-off

Tap to take-off. Lily will lift off and ascend to 1.5 meters (1 m indoors).

Landing

Tap to land. The drone will descend and land.

Flight Control



- ⦿ Please fly especially carefully as you learn the drone's flight controls. Pay strict attention to flight direction, speed, and altitude. Watch for any objects that may conflict with your flight path. Follow regulations in your area for drone flight. Start with low speeds, altitudes and near distances until you are totally comfortable with flying.

Motion Sensing

Using your mobile device's accelerometer, you can control flight by tilting your mobile device. The left-hand half of the screen is the swipe zone which controls ascent/descent and direction; the right-hand half is the motion zone which controls flying forward/backward/left/right, as in the picture below:

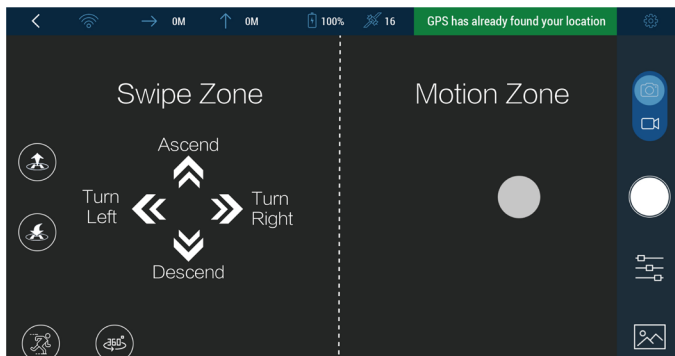

Fly forward/backward/left/right: Your mobile device tilted within 45° from horizontal, hold down on any part of the right-hand half (motion zone) of your screen, and tilt your mobile device forward/backward/left/right. Motion sensing will be activated by holding down on the screen only when the mobile device's angle from horizontal is within 45°.

Ascent/descent: Swipe the left-hand half (swipe zone) of your screen left/right. Swipe and hold to continue the movement.

Swipe the left-hand half (swipe zone) of your screen up/down. Swipe and hold to continue the movement. Turn left/right:

Free Sticks

Just like the remote controller, the free sticks method allows you to control Lily's flight by holding the virtual sticks and toggling up/down/left/right.

In Mode 1 (left-hand throttle), the left stick controls ascent/descent and direction (left-hand throttle); the right stick controls flying forward/backward/left/right, as in the picture below:

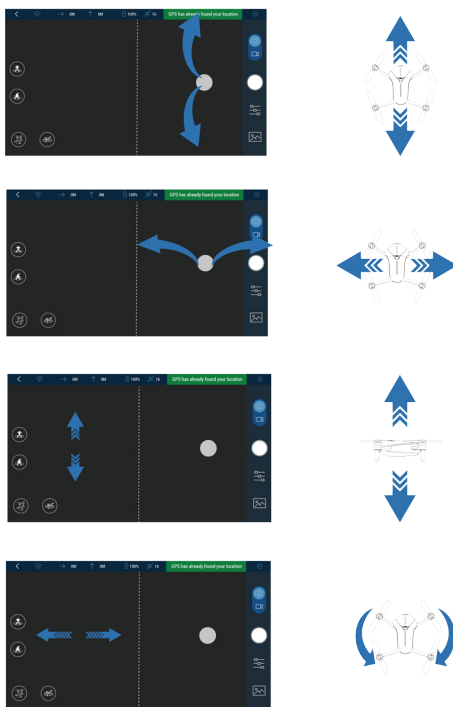

Ascent/descent: Hold down on the left stick (the dot at the center of the left circle) and toggle up and down. Toggle and hold to continue the movement.

Turn left/right: Hold down on the left stick (the dot at the center of the left circle) and toggle

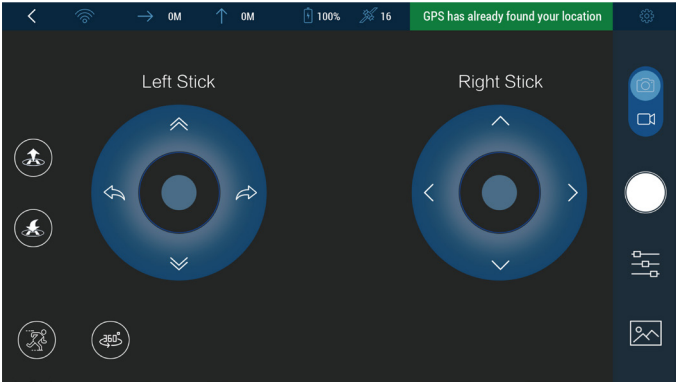

left and right. Toggle and hold to continue the movement.

Fly forward/backward/left/right: Hold down on the right stick (the dot at the center of the right circle) and toggle up/down/left/right. Toggle and hold to continue the movement.

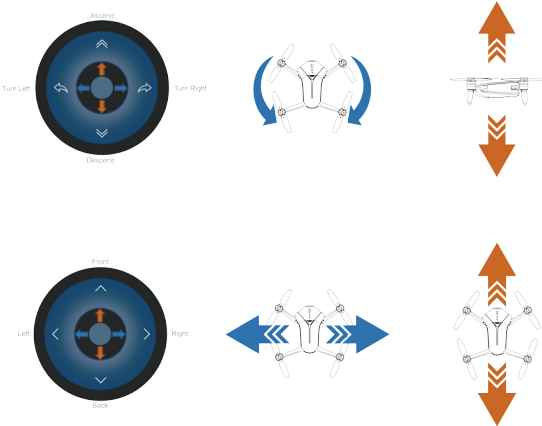



Hold down on any part of the left side of the screen, and the left stick will follow to the point where you hold down; so it is for the right stick.

Safe Sticks

Just like the remote controller, the safe sticks method allows you to control Lily's flight by tapping on the arrows on the four directions in the virtual sticks.

The operations of the safe sticks method are similar to the free sticks method. However, it uses tapping on the arrows on the four directions instead of toggling. For the details, please refer to "Free Sticks Method" on page 30.





After choosing "Safe sticks", you can choose between "Mode 1"(left-hand throttle) and "Mode 2" (right-hand throttle).

Taking Photos / Recording

Video

Taking Photos

Single shot: In the single shot mode, every time you tap the  "Shutter" button, it will take one photo.

Burst shot: In the burst shot mode, every time you tap the  "Shutter" button, it will take a series of burst shot photos.

You can take photos by using the volume buttons on your mobile device or earphones, just as you would using the  "Shutter" button.



The default mode is set to single shot. You can tap the  "Camera Settings" button to switch between the single shot mode and the burst shot mode, and select how many photos to Lily (3 photos by default) in the "Modes" menu. Please refer to "Camera Settings" on page 17.



The photo timer is off by default. You can tap the  "Photo Timer" button to activate the photo timer and select the countdown. Please refer to "Photo Timer" on page 17.

Electronic Image Stabilization

Electronic Image Stabilization (EIS) can reduce or eliminate shakiness, jitter, etc. It applies to

both the conventional video recording and the 10s auto-track short video recording. EIS is switched on by default and may be switched off before flight. How to disable EIS: Go to "Camera Settings" - "Settings" - "EIS".

Conventional Video Recording

1. Tap the Photo/Video Switch" to go to the conventional video recording interface.
2. The conventional video recording interface is as follows. Tap the  "Record" button to start recording. Tap the  "Stop Recording" button on the right-hand side of the interface to end your recording. Conventional video recording can last as long as you want. The duration will be displayed at the top of the interface.

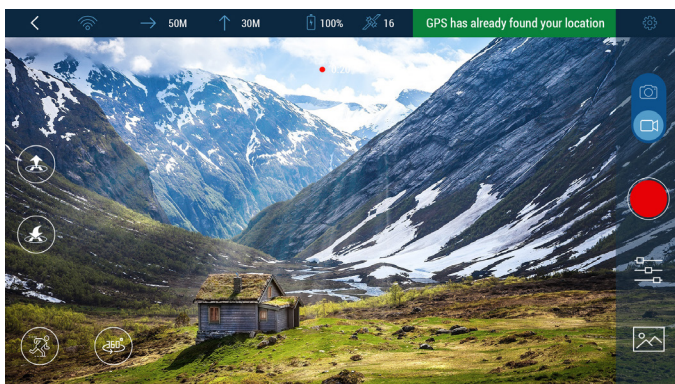

During the conventional video recording, you can use the motion sensing method, the free sticks method or the safe sticks method to control the flight.

Orbit (360°) *Only outdoors, GPS positioning*

Orbit enables the drone to automatically fly and record video around a certain point (the origin) with a user-determined altitude and radius.

When using it, first, you set the radius and the altitude to determine the orbit. Then, the aircraft flies backward and upward from the take-off point to the orbit. Finally, you specify flight along the orbit counterclockwise or clockwise. Shown as follows:

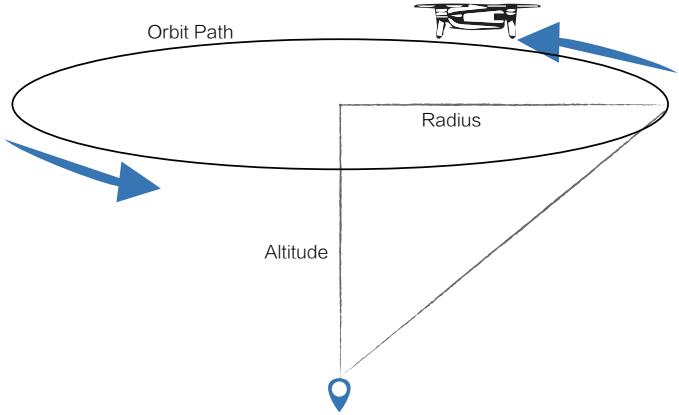

How to use it:

- 1. Fly drone to any position (the origin). Then tap the "Orbit" on the left side of the interface, and select.
- 2. In the settings interface, drag the drone icon to the blue area to set the altitude and the radius of the orbit. The horizontal axis shows the radius, and the vertical axis shows the altitude. Please make sure that there is no obstacle near the orbit

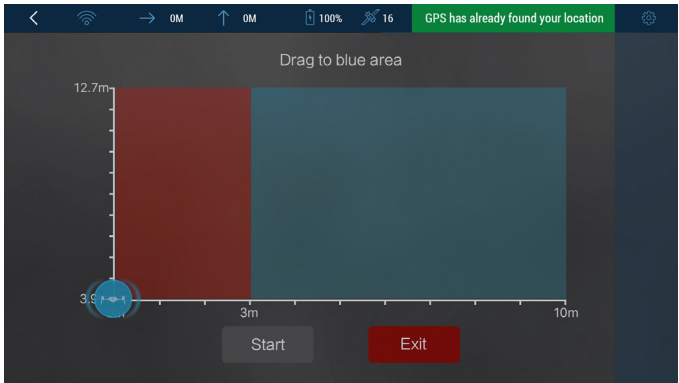

The aircraft will fly to the position where you drag it to. The radius and the altitude will be displayed on the screen as follows. After you've set the radius and the altitude, tap the "Start" button to go to the control interface.



3. In the control interface, the two round buttons respectively represent counterclockwise orbiting and clockwise orbiting. Click the left button, and the aircraft will fly counterclockwise and record video; click the right button, and the aircraft will fly clockwise. The duration will be displayed at the top of the interface.

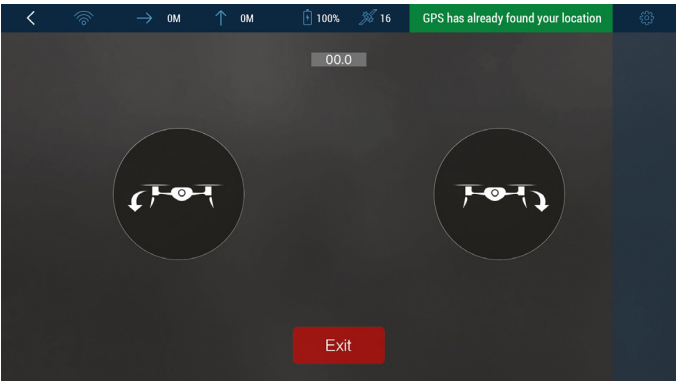



- The short video feature can be used only with outdoor GPS positioning.
- Please be careful not to fly near other objects during orbiting.

Object Tracking *Only outdoors, GPS positioning*

Object tracking enables the drone to automatically follow and record video on the moving object you've chosen.

How to use it:

1. Fly the drone to 3 meters above ground level. Then tap the bottom left-hand corner of the operation interface, and select list.
2. Draw a frame on the screen to select the object to follow. A red frame will appear. Cover the object with the red frame.



3. Tap the "Start Tracking" button in the bottom left-hand corner of the screen. The red frame will turn green, indicating the object tracking is started.

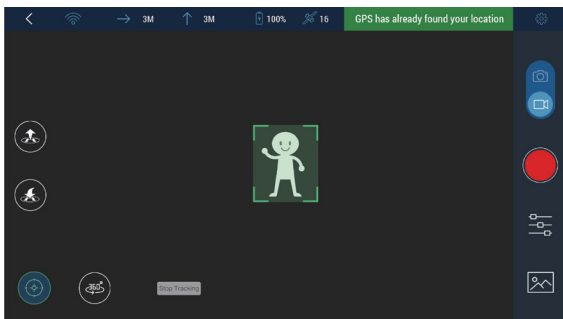

4. After you've finished tracking, tapping the "Stop Tracking" button.



- Object tracking can be used only for outdoor GPS positioning.
 - If the illumination changes drastically, or the object moves too fast, makes a sudden turn or overlaps with a similar object, the drone may lose the object.
 - In the drone loses the object it will hover awaiting your next flight command.
 - Please be careful not to collide with other objects during tracking. Tap the "Stop Tracking" button if necessary.
-

Return to Home *Only outdoors, GPS positioning*

Return to Home automatically return the drone to its take-off point and lands it. How to use it: Tap "Return to Home" in the bottom of the interface.



- Please confirm that there are no obstacles between the drone's current position and its take-off point.
 - Tap the "Stop" button, or immediately take manual control if necessary.
-



- Return to Home can be used only for outdoor GPS positioning.
-

If you require maintenance service, please contact your dealer or Lily customer service :

support@lily.camera



Warranty Card

Purchase Information

Serial No.: Purchase Date:

Dealer: Telephone:

Address:

User Name: Telephone:

Email:

Address:

Maintenance Record

| Maintenance Date | Description of Maintenance |
|------------------|----------------------------|
| | |
| | |
| | |
| | |

