

Other Uses and Add-ons:

Macro Arm (M-4): Use the M-4 module for additional versatility in flash positioning. This is especially useful in tricky situations such as shooting from a blind.

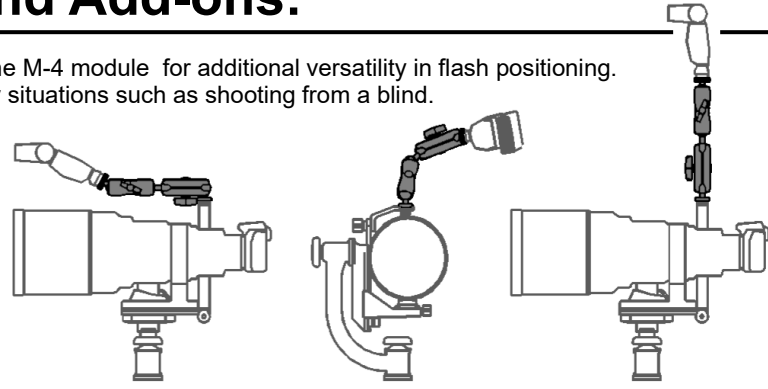

Macro Flash Bracket (F-2): The Macro Arm (M-4) can also be used to connect directly to the Quick-Release Arm (M-1). This is commonly used in macro applications or with small cameras and lenses where the upright module is not necessary.

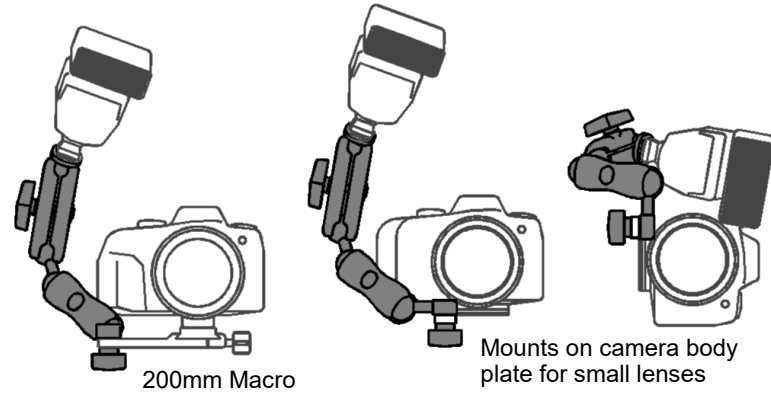

M-6 Extension Post Module: This post extends the height of your flash by up to 5" which helps reduce red eye or "steel eye" in your people or animal subjects. If you desire more extension, you can stack up to three Extension Posts to get the height you need.

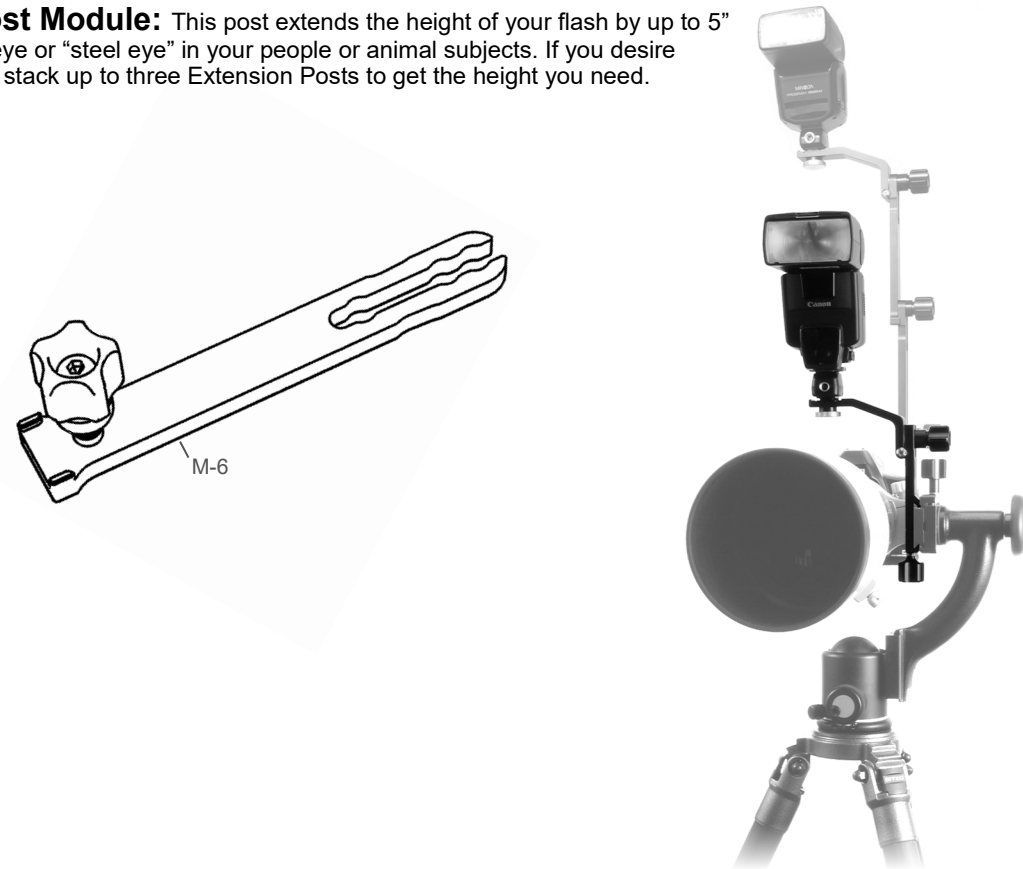

Thank you for your interest in Wimberley products. If you have any questions or comments please feel free to contact us.

F-6 Flash Bracket



Wimberley

F-6 Sidekick Flash Bracket

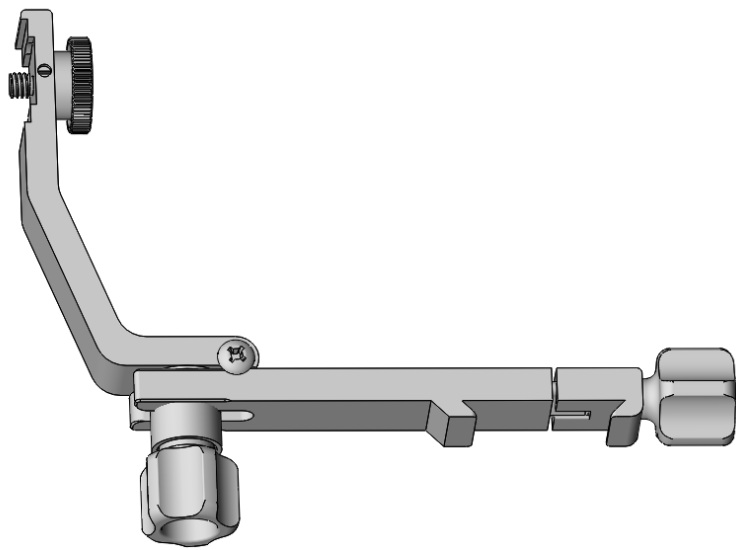

Made in USA

Package Contents:
M-1 Module: Quick-release Arm (Qty 1)
M-3 Module: Tilt Arm (Qty 1)

Dimensions (overall L x W x H): 5.7" x 1.0" x 6.7" in **Weight:** 6 oz (170g)

Wimberley, Inc. Phone: 1-434-529-8385
1750 Broadway St Toll Free: 1-888-665-2746 (USA & Canada)
Charlottesville, VA www.tripodhead.com info@tripodhead.com
22902 USA

5 Year Warranty – for details see www.tripodhead.com/warranty.cfm

Attaching the Bracket to a Lens:

The F-6 bracket attaches to your Arca-Swiss style plate using a special narrow, low-profile quick-release clamp that eliminates loose screws and the need for tools. The clamp on the bottom module (M-1) can be attached to the bottom of an Arca-Swiss style plate, or the M-1 can be flipped to attach to the top of the plate if needed. (Requires double dovetail plate)

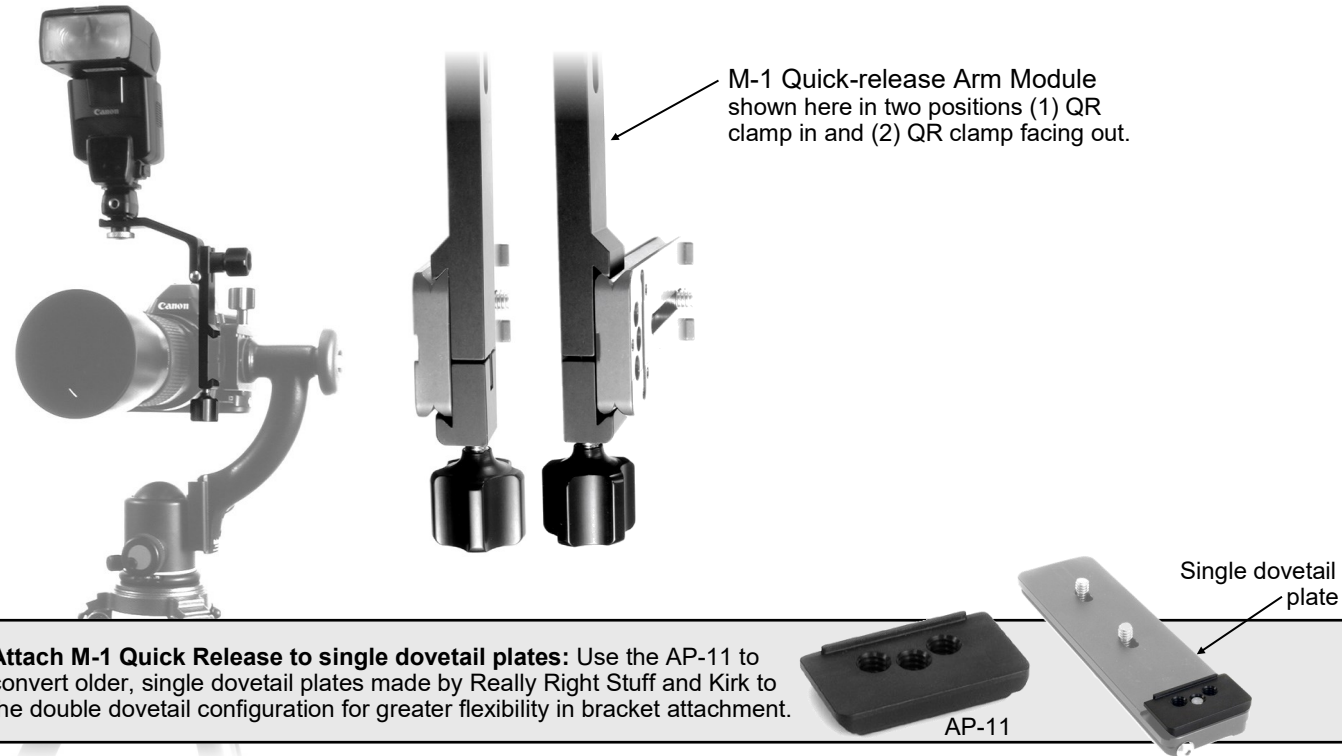

Attach M-1 Quick Release to single dovetail plates: Use the AP-11 to convert older, single dovetail plates made by Really Right Stuff and Kirk to the double dovetail configuration for greater flexibility in bracket attachment.

Attaching Your Flash Unit:

Wimberley Flash brackets have a 1/4"-20 mounting thumbscrew that attaches to an off-camera hot shoe cable or a cold shoe adapter such as the Wimberley AP-7. We do not sell flash cords. Please follow camera and flash unit recommendations when purchasing flash cords to ensure proper signal transmission.

Use the thumbscrew on the top of the M-3 Tilt Arm module to attach the shoe. Make sure the flash adapter seats snugly into the bottom notch of the Tilt Arm module. There should be no need to over-tighten.

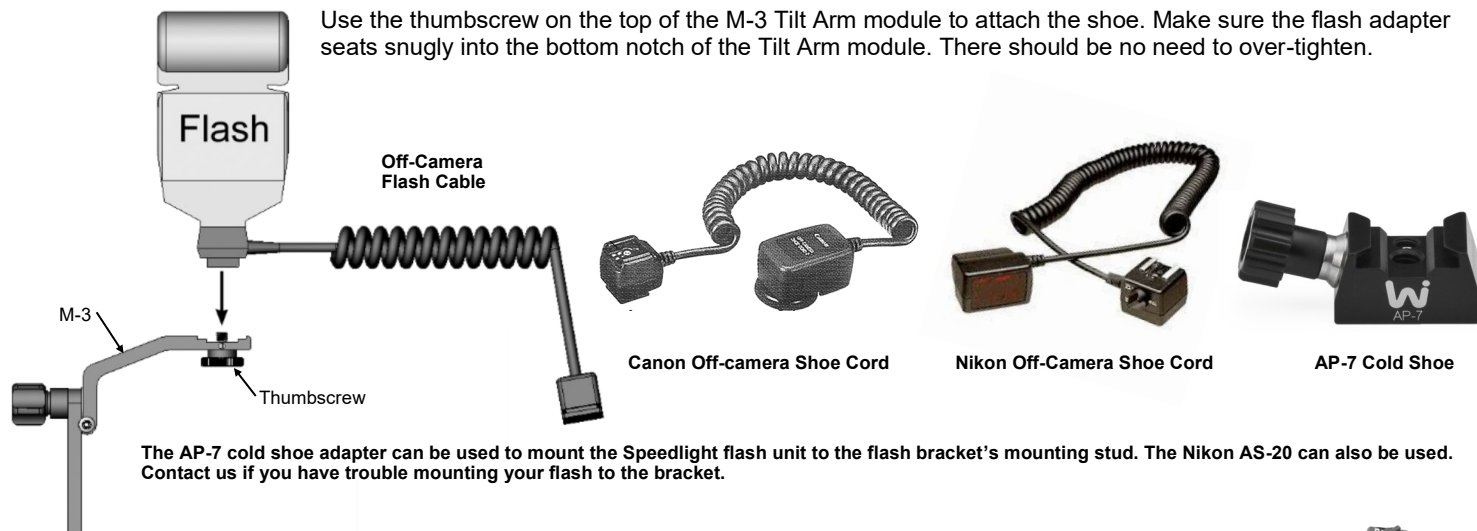

Nikon SC-29 compatibility note:

The Nikon SC-29 cord requires the use our FA-11 Flash Cord Adapter (sold separately) to attach the cord snugly to the bracket because the cord mounting foot is slightly too wide to fit properly in the slot on the flash arm.

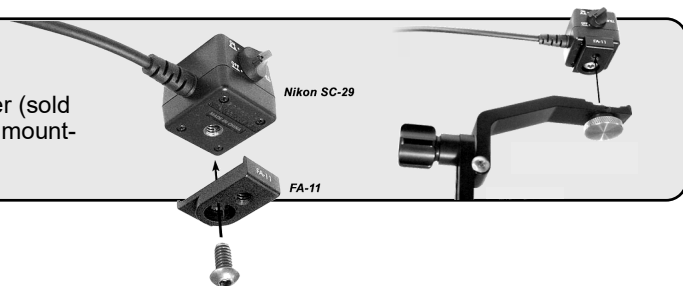

Positioning your Flash:

The Modular Flash Bracket System design allows you to easily disassemble brackets for convenient storage. It also allows you to adjust the size of the bracket to fit different sized lenses using the keyed slots of the upright module to increase or decrease the height of the flash unit. Flip the Tilt Arm upside down to lower the flash even further. When the M-3 is used flipped upside down, the thumb-screw must also be flipped. Below are some of the configurations possible.

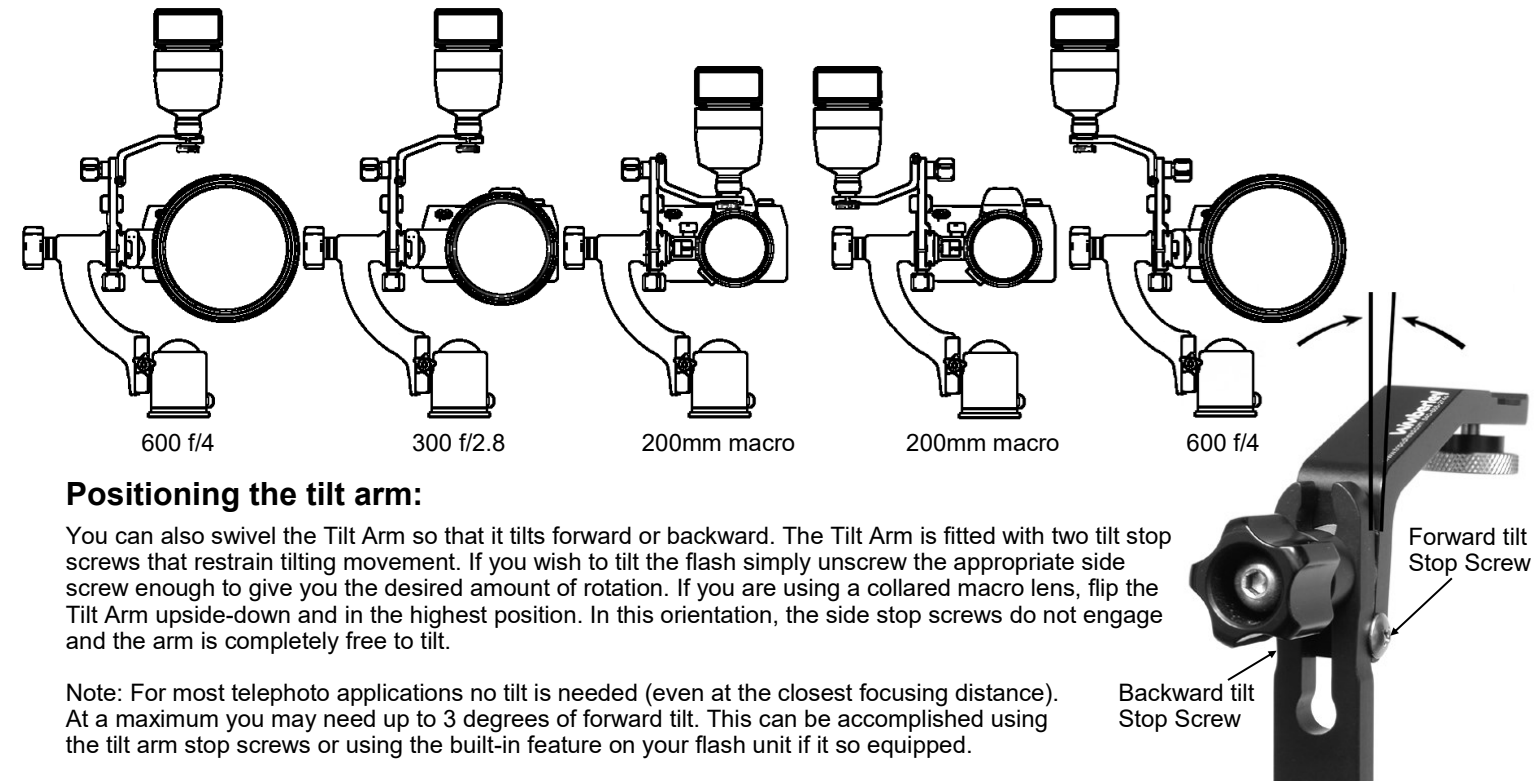

Positioning the tilt arm:

You can also swivel the Tilt Arm so that it tilts forward or backward. The Tilt Arm is fitted with two tilt stop screws that restrain tilting movement. If you wish to tilt the flash simply unscrew the appropriate side screw enough to give you the desired amount of rotation. If you are using a collared macro lens, flip the Tilt Arm upside-down and in the highest position. In this orientation, the side stop screws do not engage and the arm is completely free to tilt.

Note: For most telephoto applications no tilt is needed (even at the closest focusing distance). At a maximum you may need up to 3 degrees of forward tilt. This can be accomplished using the tilt arm stop screws or using the built-in feature on your flash unit if it so equipped.

Connecting Flash Bracket Modules:

(The figure below shows the connection between M-3 and upright module; the same principle applies for other module connections.)

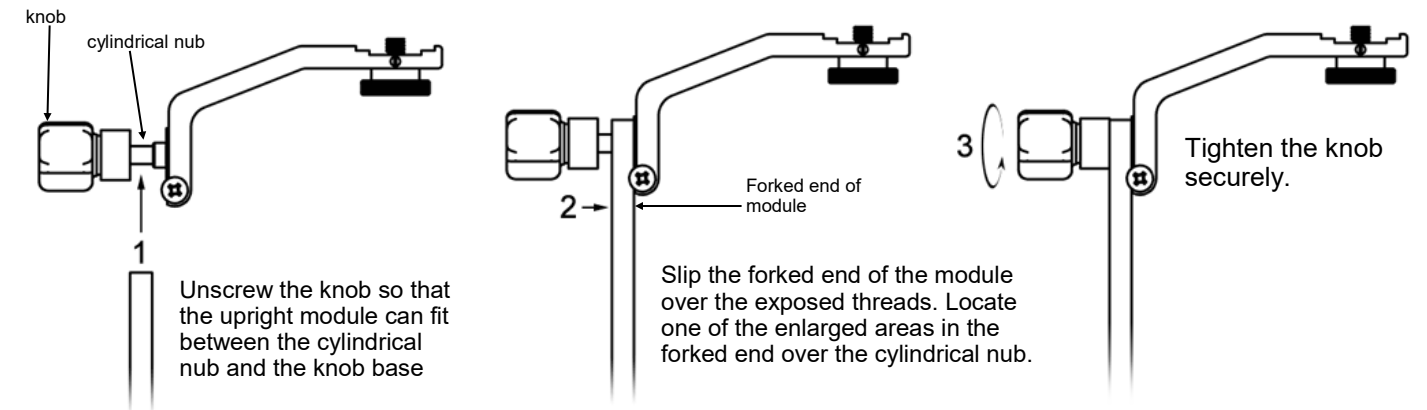

Tip: if you find the metal knobs difficult to grip, try wrapping several layers of self-fusing rubber grip tape (3M 2155) around the knob to cushion it and make it easier to grip in the field.

Feel free to contact us if you have any questions.

