

3M

mobile projector



operator's
guide

Contents

Important Notice	3
Technical Support	3
Intended Use Statement	3
Safety Information	4
Safety Labels	8
Introduction	9
Overview	9
Package Contents	10
Parts of Projector	11
Getting Started	13
Home Screen	29
Remote Control (Optional Accessory)	41
Search	43
Opening and Switching Applications	44
Transferring Files to the Projector	45
Video/VGA Pass Through	49
Gallery	55
Music	63
Video Player	71
Clock	74
Documents To Go	78
Word To Go™	86
Sheet To Go®	97
Slideshow To Go®	120
PDF to Go	130
Fun Pack	133
Cannon Ball Pro	137
Settings	138
Limited Warranty	144

Important Notice

All statements, technical information, and recommendations related to 3M's products are based on information believed to be reliable, but the accuracy or completeness is not guaranteed. Before using this product, you must evaluate it and determine if it is suitable for your intended application. You assume all risks and liability associated with such use. Any statements related to the product which are not contained in 3M's current publications, or any contrary statements contained on your purchase order shall have no force or effect unless expressly set forth in a written agreement signed by an authorized officer of 3M.

Technical Support

For technical support, call 1-866-631-1656 or email meetings@mmm.com.

Intended Use Statement

The 3M Mobile Projector MP220 is designed to operate with the 3M specified battery and 3M power adapter in normal office or home environments.

- 0°–30°C (32°–86°F)
- 10–80% RH (without condensation)
- 0–1829 m (0–6000 feet) above sea level

Continued exposure to smoke, grease, oil and other airborne contaminants can affect the operation or performance of the projector. Use of this product in adverse conditions will void the product warranty.

Safety Information

Please read, understand, and follow all safety information contained in these instructions prior to the use of this projector. Retain these instructions for future reference.

Explanation of Signal Word Consequences	
⚠ Warning:	Indicates a potentially hazardous situation, which, if not avoided, could result in death or serious injury and/or property damage.
⚠ Caution:	Indicates a potentially hazardous situation, which, if not avoided, may result in minor or moderate injury and/or property damage.
⚠ Warning:	Hazardous voltage

 **Warning**

To reduce the risk associated with hazardous voltage:

- Do not modify this product in any way. Use only 3M approved replacement components.
- Do not attempt to service this projector other than battery replacement. There are no user-serviceable parts other than the battery. Service to be performed only by a 3M authorized service provider using 3M approved system components.
- Do not use the wall power supply in a wet environment.
- Do not use with a damaged wall power supply. Replace damaged part prior to use.

To reduce the risk associated with fire and explosion:

- Do not immerse the projector or battery in any liquid or allow either to get wet.
- Use only 3M approved power supply and lithium ion battery provided.
- Do not disassemble or short circuit the battery.
- Do not dispose of the battery by incineration or fire.
- Do not operate this projector in any environment above 30°C (86°F).
- Do not expose the projector or battery to direct sunlight in a closed space such as a vehicle.
- Do not carry the battery in pockets, purses or handbags where it may contact metal objects.
- Do not place battery in contact with metal objects.
- Do not expose or store battery in direct sunlight or excessive heat (>60°C [140°F]), or in moist or caustic environments.

⚠ Warning**To reduce the risks associated with driver distraction:**

- Do not use this projector in a moving motor vehicle.

To reduce the risks associated with choking:

- Keep AV adapters and other small parts away from young children.

To reduce the risk associated with fire and explosion, battery leakage or overheating:

- Do not immerse the battery in water or allow it to get wet.
- Do not reverse the positive(+) and negative(-) terminals.
- Do not connect the battery directly to a wall outlet. Use only the 3M specified wall charger or automobile charger.
- Do not strike, throw or subject the battery to physical shock.
- Do not pierce the battery or break it open.
- Keep batteries out of the reach of children.
- Do not recharge the battery near a heat source or in extremely hot conditions.
- Do not use the battery if it gives off an odor, generates heat, or becomes discolored or deformed.
- Keep away from exposed flames if the battery leaks or emits an odor.
- Flush the eyes with water and seek medical attention if the battery leaks and battery fluid gets in the eyes.

 **Caution**

To reduce the risks associated with hearing loss:

- Be sure to read earphone manufacturer's instructions with respect to volume level.
- User is responsible to set a safe volume level.

To reduce the risk associated with environmental contamination:

- Dispose of all system components in accordance with applicable government regulations.

To reduce the risks associated with LED bright light:

- Do not stare directly into the projector lens.

To reduce the risks associated with tripping and falling:

- Position the charging cord and data cables so that they are not a tripping hazard.

SAVE THESE INSTRUCTIONS

Safety Labels

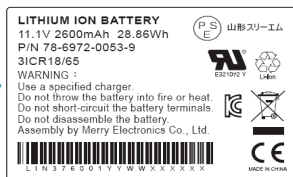
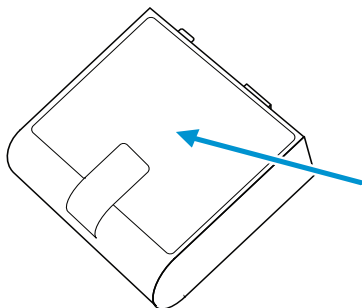

LITHIUM ION BATTERY

Model No. LIN376-001

28.86Wh (11.1V 2600mAh x 3)

P/N 78-6972-0053-9

⚠ Warning

- Use a specified charger.
- Do not throw the battery into fire or heat.
- Do not short-circuit the battery terminals.
- Do not disassemble the battery.

Charging Specification

Standard Charge	11.1V/1.3A
Cut Off Voltage	8.5V
Max Charge	12.3V/1.3A

LED Light Output

CLASS 1 LED PRODUCT	IEC60825-1 :1993+A1 :1997+A2:2001	Maximum Radiant Power: 1.693 mW
---------------------	--------------------------------------	------------------------------------

Introduction

Thank You for Choosing 3M

This product has been produced in accordance with 3M quality and safety standards to provide smooth and trouble-free use in the years to come. For optimum performance, please follow the operating instructions carefully.

Overview

Product Features

The 3M™ Mobile Projector MP220 makes it easy to project information almost anywhere you go, instantly — all with 65 lumens of brightness. It is perfect for presenting to small groups. The 3M MP220 projector includes these features:

- + Battery or plug-in for super mobility
- + 2-hour battery life ensures that it's ready when you are
- + WSVGA resolution for crisp image
- + Simple-to-use Android™ OS and user interface
- + Optical mouse, buttons
- + 2 x 0.75W speakers

Package Contents

- 1 3M MP220 Projector
- 2 Power Adapter
- 3 Outlet Adapters (4)
- 4 USB Cable
- 5 Product Warranty and Safety Guide
- 6 Quick Start Guide

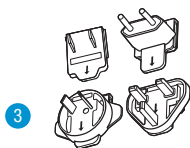
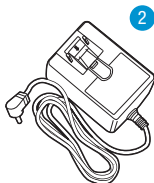
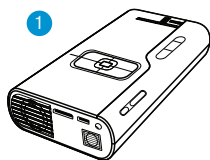

Parts of Projector

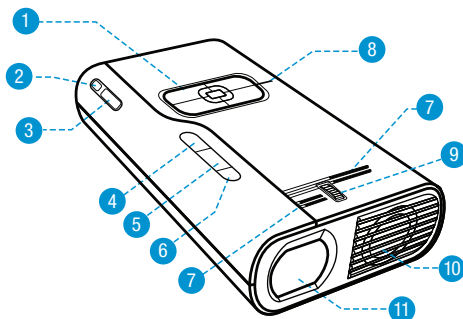

- 1 **Navigation pad** – For more information, see “Navigation Pad” on page 21
- 2 **Power On/Off** – Powers the projector on and off, or turns off the lamp.
- 3 **microSD card slot** – Accepts a 32GB or less microSD card.
- 4 **Volume down** – Turns down speaker or audio out output.
- 5 **Volume up** – Turns up speaker or audio out output.
- 6 **Infrared sensor** – Accepts commands from 3M remote control. Remote control sold separately.
- 7 **Air vents** – Do not block fans or vents while projector is operating or cooling down. This will cause projector to overheat and automatically turn off.
- 8 **Status indicator LED**
- 9 **Focus wheel** – Adjusts to sharpen image.
- 10 **Cooling fans** – Do not block fans or vents while projector is operating or cooling down. This will cause projector to overheat and automatically turn off.
- 11 **Lens**

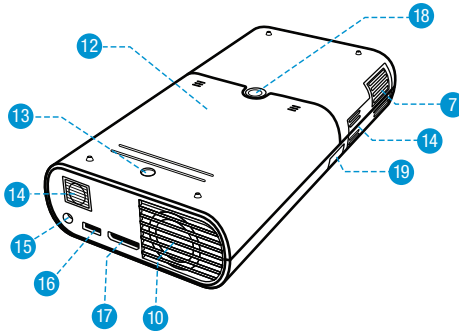

- 12 Battery compartment
- 13 Battery cover securing screw
- 14 Speakers
- 15 DC power in – Powers the projector or charges the battery using the 3M power supply.
- 16 microUSB – Transfer files back and forth from your computer to the projector. Attach a USB computer mouse, or keyboard. Access files on USB memory stick.
- 17 VGA-AV – Connect the 3M VGA or Video cable to your computer, DVD Player, or other video device and project its image. Cables sold separately.
- 18 Tripod Mount
- 19 Earphone jack – Attach earphones or computer speakers.

Getting Started

Power Adapter

The power adapter is used to charge the battery or power the projector. There are four outlet adapters to give you the flexibility to power the 3M MP220 in most countries.

When the power adapter is first shipped, it is fitted with a blank outlet adapter. This must be removed before installing an outlet adapter.

Installing an Outlet Adapter onto the Power Adapter

- 1 Press the "PUSH" button on the underside of the power adapter.
- 2 Remove the blank outlet adapter by sliding up.

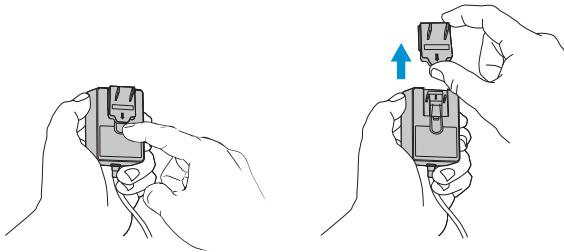

- 3 Select the outlet adapter that will plug into your wall outlet and align to the power adapter.
- 4 Slide the outlet adapter down until it clicks into place.

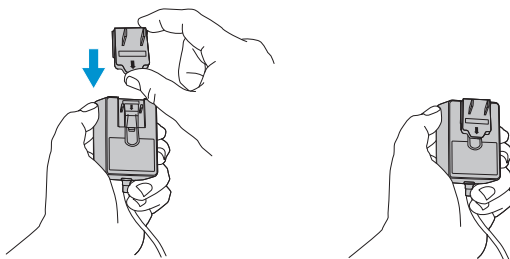

Battery

The 3M projector comes with a rechargeable battery. When the projector is shipped, there is a protective film between the battery and the battery contacts on the projector.

Battery Maintenance Tips:

- Remove the battery when the projector will not be used for one week or longer.
- Charge and discharge the battery by turning on the projector at least once a month.
- When storing the battery for more than a month, store it at 50% charge. The battery is at 50% charge when half of the battery icon is green.
- Do not store the battery when it is fully discharged. It will lose the ability to charge.

Removing the Protective Film

Remove the protective film by pulling in the direction shown below.

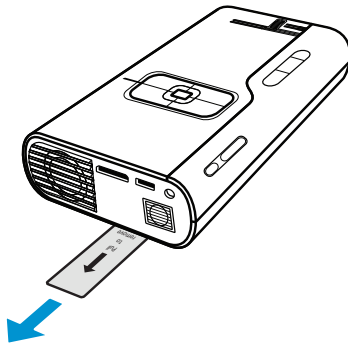

Replacing the battery

Remove the battery

- 1 Remove the screw securing the battery cover using a Phillips-head ("crosshead") screwdriver.

- 2 Slide the battery cover off.
- 3 Lift the battery out.

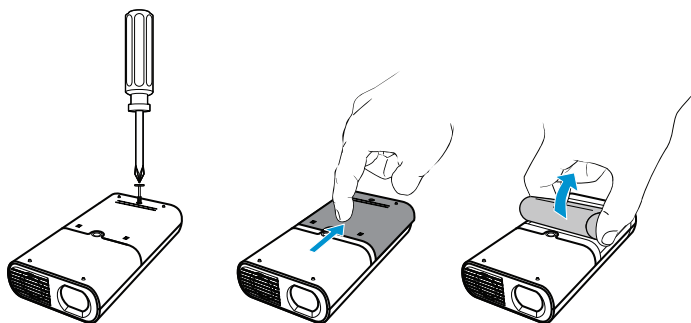

Install the battery

- 1 Orient the battery so that its contacts line up with the battery contacts inside the projector.
- 2 Place the battery into the battery compartment.
- 3 Slide the battery cover on.
- 4 Replace the battery cover securing the screw using a Phillips-head ("crosshead") screwdriver.

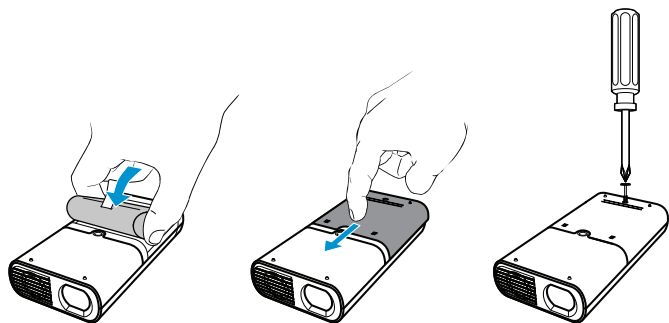

Charging the battery

The 3M MP220 rechargeable battery gives you up to two hours of battery life. When the battery needs to be charged, the status indicator LED starts flashing red. The battery should be fully charged before using the 3M MP220 projector.

Charge the battery:

- 1 Turn the projector power off.
- 2 Connect the power adapter to the projector's DC input.
- 3 Connect the other end of the power adapter to the electrical outlet.
- 4 The status indicator will change to amber while the battery is charging.
- 5 Allow three hours to fully charge the battery. When charging is complete, the status indicator will turn off.

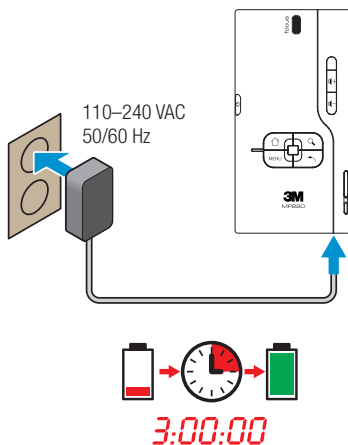

Battery Charging Notes:

- If the projector power is off, allow three hours for the battery to fully recharge. If the projector power is on, the battery will take longer to charge.
- The battery has a lifespan and ages every time it is fully charged and discharged. The battery will gradually lose charge capacity as it ages.
- The battery cannot be charged using the USB port.

Power Button

The power button turns on or shuts down the projector. When you turn on the projector, it is ready to use in 30 seconds. While the projector is on, you can turn the projector's lamp on or off using the power button. The projector's lamp turns on and off in only a second. You can turn on the projector's lamp by pressing any button on the projector.

Turning the Projector On

Press the power button.

Note that the projector might take 30 seconds or more to power on.

Turning the Projector Off

- 1 Press and hold the power button until the device options menu appears on the screen.
- 2 Select Power off from the menu.
- 3 Confirm that you wish to turn the projector off by selecting OK

Turning the Lamp On and Off

You can turn the projector's lamp off without turning the projector off. Press and quickly release the power button and the projector's lamp will turn off. The projector lamp will turn off immediately while the cooling fans continue to run for a few seconds.

While the projector lamp is off, the status indicator will flash green. This tells you that the lamp is off but the projector is still on. Press any button on the projector and the lamp will turn on.

Important Note: When the lamp is off, the projector continues to use power. Do not place projector in a bag in this state as it can easily be turned back on.

Status Indicator lights

The status indicator light provides information about the projector's power, battery, and error status.

Status Indicator Light	Meaning
Solid amber	Projector is charging
Solid Green	Projector is on
Slow flashing green	The projector is on but the projector's lamp is off.
Flashes red twice	The projector cannot charge the battery
Flashes amber	Projector has overheated
Flashes red	The battery power is low.

Adjusting Image Size

The 3M MP220 projector can project a diagonal image of 10 to 70 inches (254–1778 mm). Refer to the chart for associated dimensions.

Image Size Diagonal	Width	Height	Distance
10 in (25.4 cm)	8 5/8 in (21.9 cm)	5 1/16 in (12.8 cm)	18 1/2 in (46.7 cm)
20 in (50.8 cm)	17 1/4 in (43.8 cm)	10 1/8 in (25.7 cm)	36 3/4 in (93.5 cm)
30 in (76.2 cm)	25 7/8 in (65.7 cm)	15 1/4 in (38.5 cm)	55 1/4 in (140.2 cm)
40 in (101.6 cm)	34 1/2 in (87.7 cm)	20 1/4 in (51.4 cm)	73 5/8 in (186.9 cm)
50 in (127 cm)	43 1/8 in (109.6 cm)	25 1/4 in (64.2 cm)	92 in (233.7 cm)
60 in (152.4 cm)	51 3/4 in (131.5 cm)	30 1/2 in (77 cm)	110 3/8 in (280.4 cm)
70 in (177.8 cm)	60 1/2 in (153.4 cm)	35 3/8 in (89.9 cm)	129 in (327.2 cm)

Important Note: As you increase the size of the projected image, you will need to decrease (darken) the ambient room lighting.

Adjusting the Focus

Rotate the focus wheel to sharpen the image.

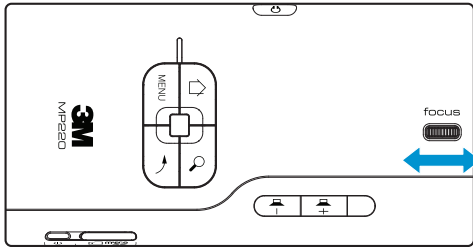

Attaching the Tripod (Optional Accessory)

The bottom of the projector includes a tripod socket that fits most standard camera tripods, including the optional 3M tripod (78-6972-0073-7).

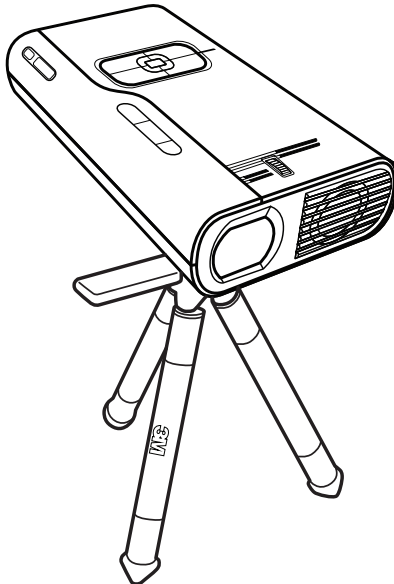

Volume Up/Down

The volume up and down buttons adjust the volume for media such as videos and music. The volume buttons also adjust volume for audio input through the VGA-A/V port.

Display Volume Level: Press the volume up or down button to display the volume slider.



Increase or Decrease Volume: Press the volume up button to increase the audio volume or press the volume down button to decrease the audio volume.

Quickly Increase or Decrease Volume: Press and hold the volume up button to quickly increase the audio volume or press and hold the volume down to quickly decrease or mute the audio volume.

Navigation Pad

The navigation pad allows you the maneuver through the screens. Each one of the buttons has one or more functions or modes.

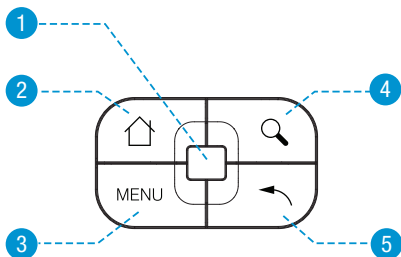

- 1 Touch Sensor** – Moves the mouse pointer or selector on the screen.
- 2 Home Button** – Press to open the Home screen. Press and hold to open recently used applications.
- 3 Menu Button** – Press to open the menu for the current screen or application.
- 4 Search Button** – Press to open search. Press and hold to open the Mouse mode menu.
- 5 Back Button** – Press to open previous screen or close onscreen keyboard.

Home button

Returning to the Home screen

Switching between recently used applications

Menu Button

Opening options and context menus. Press and hold to display the on-screen keyboard

Back Button

Returning to the previous screen

Search Button

The Search button opens the Search app or the Touch Sensor Mode dialog.

Opening the Search Application: Press the Home button and then the Search button. The Search app will open.

Switching Touch Sensor Mode: Press and hold the Search button until the Touch Sensor Mode switch dialog appears. Press the OK button if you want to switch the mode. See the Touch Sensor Sections for more information.

Touch Sensor

The Touch Sensor is located in the center of the navigation pad and moves the mouse pointer, selector or cursor on the screen. The Touch Sensor has two modes: mouse point and trackball.

- When in mouse pointer mode, you move your finger across the Touch Sensor to control the mouse pointer (or small arrow) on the screen. Use the mouse pointer to select screen menu items, launch applications and move icons.
- When in trackball, you move a red or gray selector.

Switching Between Mouse and Trackball Mode

There are two ways to switch between the two modes: Use the Search Button or Settings Menu.

Switch the modes using the Search Button: Press and hold the Search button and the “Touch Sensor Mode switch” dialog will appear. Press OK to switch from the mode.

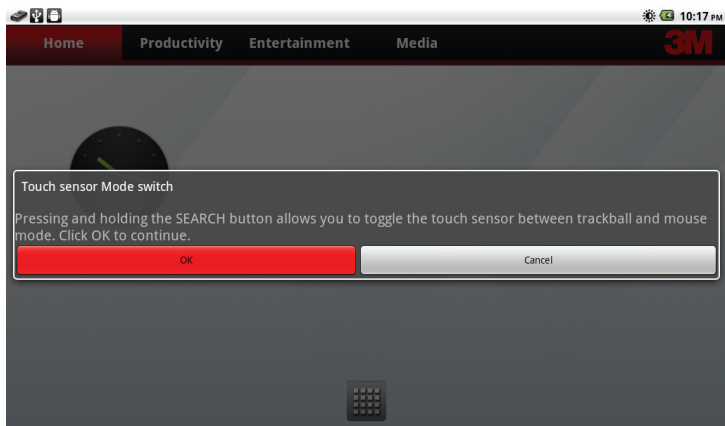

Switch the modes using the Setting Screen: Press the Home and then the Menu button. An options menu will appear. Select “Settings” and the Setting Screen will appear. Select Touch Sensor and put a check mark beside Mouse if you want to use mouse mode or uncheck if you want to use trackball mode.

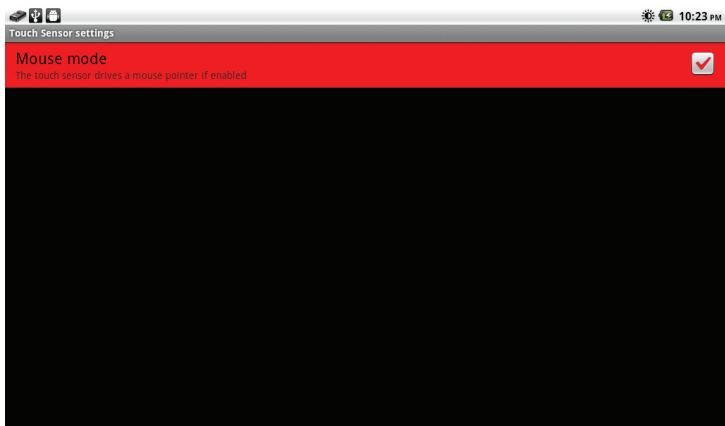

Mouse Mode

Mouse Mode uses a pointer to select items on the screen and navigate the screens and menus. Just like using your computer’s mouse to move the pointer on the computer’s screen, you can move your finger across the Touch Sensor and move the pointer.

Moving the mouse pointer: Lightly drag your finger across the Touch Sensor in the direction you want the pointer to move.

Clicking an item on the screen: Use the pointer and Touch Sensor to click application icons and settings icons or type letters using the onscreen keyboard. Move the pointer to where it is over the item and press the Touch Sensor to click the item.

Double-Clicking an item: Quickly press the Touch Sensor twice to zoom and unzoom a picture in the gallery, for example.

Click and Hold: Use the Touch Sensor to activate additional features by pressing down and holding. You can add a new shortcut or widget to the Home screen by clicking and holding down the Touch Sensor until the dialog appears.

Click, hold and swipe: You can view the next photo in the Gallery by clicking and holding the Touch Sensor and then moving your finger across the sensor in the direction you want to move through the photo album.

Trackball Mode

Trackball Mode highlights selected items on the screen and the focus of the screen follows the highlighter. Move your finger across the Touch Sensor to select items on the screen. The selected item is highlighted gray, red, blue, or yellow depending on the screen, app, or dialog.

Select an item: Gently move your finger across the Touch Sensor in the direction of the item you wish to select. This works best if you move your finger up and down or right and left rather than diagonally.

Click: Press the Touch Sensor to select the item. You will feel and hear the Touch Sensor click.

Double-Click: Quickly press the Touch Sensor twice to zoom and unzoom a picture in the gallery, for example.

Click and Hold: Press and hold the Touch Sensor down while an app or widget on the Home screen is selected and the choose your action dialog will appear.

Initial Setup

The first time you switch on your MP220, you will need to set up your locale and the date & time.

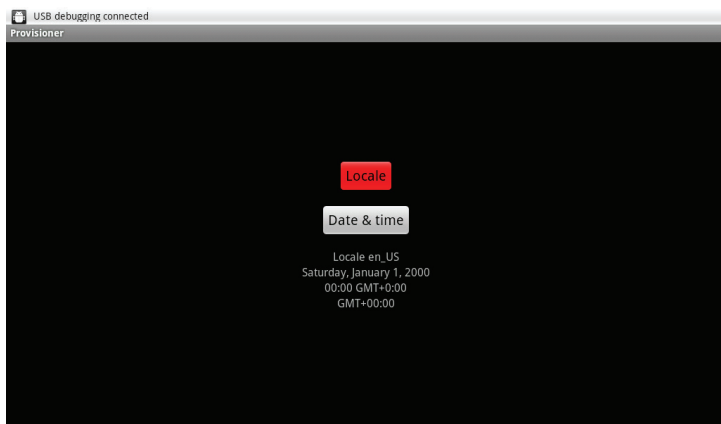

Setting your Locale

To set the locale, click Locale. This chooses the language that the projector's interface and menus display. The following screen will appear. Click on your locale. If your locale does not appear on the screen, you may have to scroll down.

Note: You can customize some parts of the projector's interface, such as the tabs on the Home Screen, that do not change with this setting.

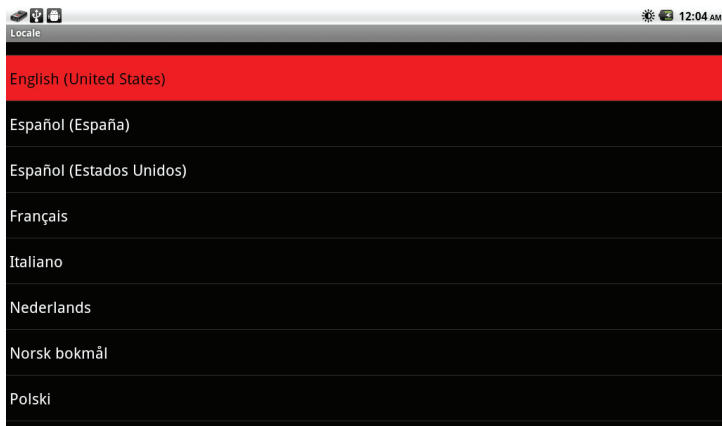

Setting the Date and Time

To set the date and time, click Date & Time. The following screen will appear.

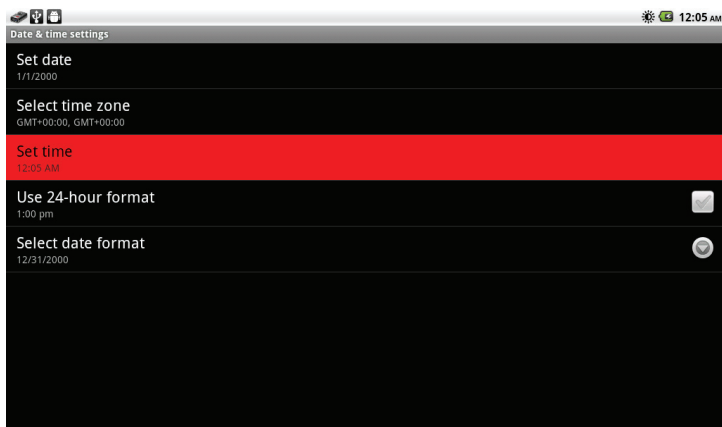

Setting the Time

Click on Set time.

The following screen will appear. Click the + or – symbols to change the hours and minutes. To change from AM to PM, click on AM. Once finished, click Set.

Note: Clicking and holding + or - will cycle through the hours or minutes.

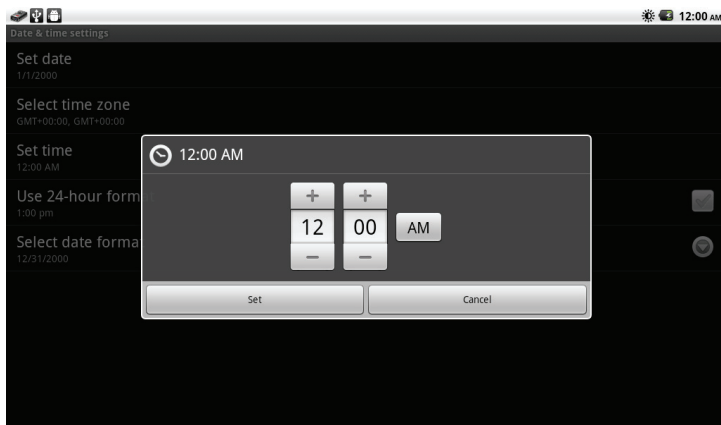

Setting the Date

Click on Set date.

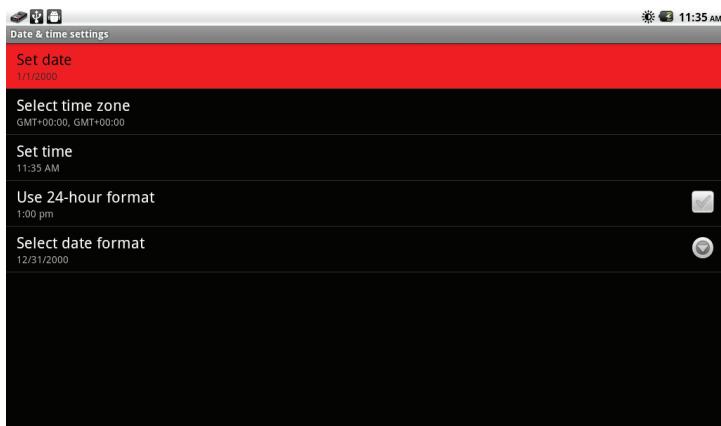

The following screen will appear. Click the + or – symbols to change the month, day and year. Once finished, click Set.

Note: Clicking and holding + or - will cycle through the days, months or years.

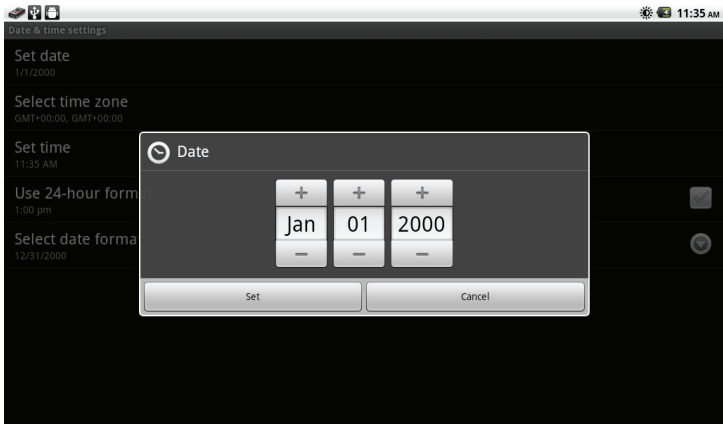

To return to the Home screen, press the Home key on the navigation panel.

Note: You can change the language and date or time at any time by going into Settings and choosing Language or Date & Time. For more information, see "Settings" on page 138.

Home Screen

After booting up, the Home screen will display.

The Home screen displays

- application icons,
- widgets, and
- shortcuts

You can customize the Home screen display:

- by changing the wallpaper (or background) and tab names, or
- by adding shortcuts or widget to a tab.

To learn more about customizing the Home screen, please see “Customizing the Home Screen” on page 32.

The Status bar is at the top of the Home screen. The Status bar displays information about the projector and its status. For more information about the status bar and icons you might see there, see “Status Bar” on page 30.

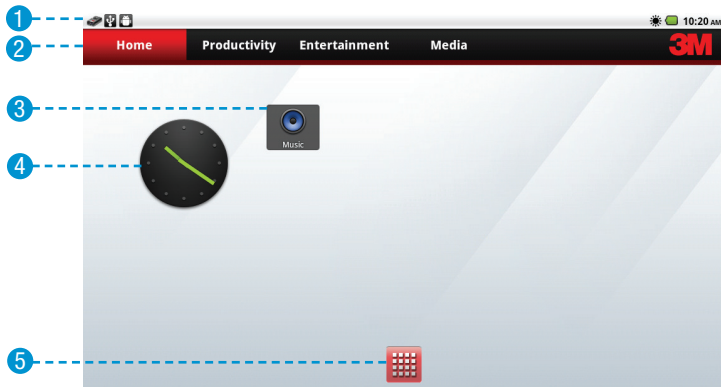

- 1 Status bar** - Provides information about the projector such as connectivity, battery power and time.
- 2 Pane Tabs** – Use customizable tabs to provide a way to organize applications and widgets on the HOME SCREEN

- 3 **Shortcuts** – Provides quick access to application, music playlist, and projector settings. See Adding Shortcuts to Home screen for more information.
- 4 **Widget** – Provides the application's functions from the Home screen.
- 5 **App Launcher** - Takes you to a list of installed apps.

Status Bar



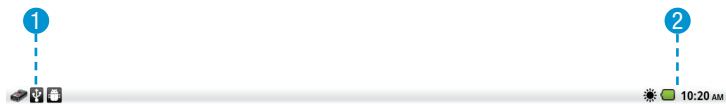



The status bar shows the time, battery status, brightness level and system notifications. It appears at the top of every screen. The status icons appear on the right and notification on the left.



- 1 Notifications Area
- 2 Projector Status Area

Projector Status Area

The Status icons provide information about the projector such as battery level and projector brightness. Below is a list and their descriptions.

-  Battery is very low
-  Battery is partially drained
-  Battery is full
-  Battery is charging
-  Brightness at maximum
-  Brightness at minimum
-  Alarm is set

Notifications Area

The Notification icons make you aware of events occurring in the background. Here is a list of icons you may see. For more information, see Notifications.



Media is being scanned



Video/VGA Pass Through is ready for use



Song is playing



The projector has unmounted the SD card or the SD card is safe to remove



Mounting SD Card



SD card is full



USB is connected

Home Screen Tabs

The Home Screen Tabs provides a way for you to organize the available shortcuts and widgets. Each tab contains its own set of shortcuts and widgets and they can be arranged in any order.

Additionally, you can modify the tab labels and decide whether or not the label appears on the Home Screen. See “Customizing the Home Screen” on page 32.

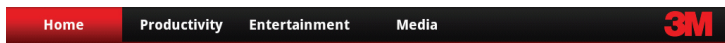

Selecting a Home Screen Tab

- **Mouse Mode:** Position the mouse pointer over the tab and press the Touch Sensor.
- **Using Trackball Mode:** Move your finger across the Touch Sensor and you will see a gray highlight moving from one tab to another. Highlight the tab and press the Touch Sensor to select it. The tab will turn red and the shortcuts and widgets in the tab will appear.

Add a Shortcut or Widget

- **Mouse Mode:** Move the mouse pointer to a location where you want the item within the Home screen tabs. Press and hold the Touch Sensor. Select Shortcuts or Widget from the Add to Home screen dialog. Select the application or widget you wish to add.
- **Mouse or Trackball Modes:** Press the Menu button. Choose Add from the options menu. Select Shortcuts or Widgets. Choose the shortcut or widget you wish to add.

Remove a Shortcut or Widget

- **Mouse Mode:** Move the mouse pointer over the item to be removed. Press and hold the Touch Sensor and drag your finger across the Touch Sensor to move the item into the trash can located at the bottom in the center of the screen.
- **Trackball Mode:** Highlight the item. Press and hold the Touch Sensor. Select Remove.

Move a Shortcut or Widget

- **Mouse Mode:** Move the mouse pointer over the item to be removed. Press and hold the Touch Sensor. Drag your finger across the Touch Sensor to move the item towards the location where you want to place it.
- **Trackball Mode:** Highlight the item. Press and hold the Touch Sensor and the Choose your action dialog appears. Select one of the arrows.

Customizing the Home Screen

You can customize the Home Screen further with the options menu items: Wallpaper and Launcher Settings.

Customize the Wallpaper

- 1 From the Home screen, press the Menu key.
- 2 Select Wallpaper from the options.
- 3 Browse to the location of the image you wish to use as wallpaper.
- 4 Click on the image.

Note: You choose an image or animated wallpaper from one of three locations: Gallery, Live wallpapers or Wallpapers.

- *Gallery refers to your own photo album.*
- *Live wallpapers contains animated wallpaper.*
- *Wallpapers contains still (unanimated) wallpaper.*

Launcher Settings

The Launcher Settings is where you customize the appearance of the Home Screen items and tabs.

Customizing the Home Screen Tabs

You can change the names, show or hide the tabs and set the default tab selected.

Home Screen Tab Label:

- 1 Press the Home button.
- 2 Press the Menu button.
- 3 Select Launcher Settings.
- 4 Select Tab Settings and then Tab Names.
- 5 Select the tab name you want to rename. The Rename dialog will appear.
- 6 Select the text entry box to display the onscreen keyboard.
- 7 Enter the new name. For more information on entering text, see “Onscreen Keyboard” on page 37.

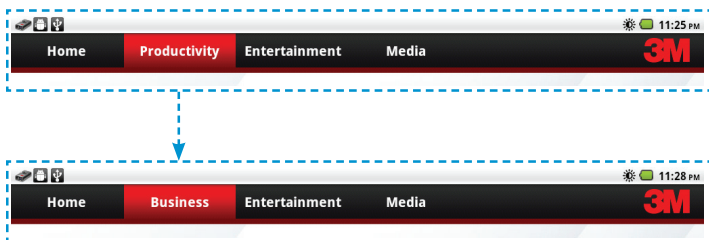

Show or Hide a Tab:

- 1 Press the Home button.
- 2 Press the Menu button.
- 3 Select Launcher Settings.
- 4 Select Tab Settings and then Show/Hide Tabs.
- 5 Place a checkmark beside the tabs you want to appear on the Home screen.

Set the Tab that is highlighted by default:



- 1 Press the Home button.
- 2 Press the Menu button.
- 3 Select Launcher Settings.
- 4 Select Tab Settings and then Default Tab.
- 5 Place a checkmark beside the tabs you want to appear on the Home screen.

Customizing the Icons on the Home Screen

You can customize the shortcut and widget icons that appear on the Home Screen. You can choose to either display or not display the labels, icon shadows or large icons.

Change Icon Appearance Settings:

- 1 Press Home.
- 2 Press Menu.
- 3 Select Launcher Settings.
- 4 Select Appearance Settings. The table below shows you how each setting affects the icons on the Home screen.

Setting	<input type="checkbox"/>	<input checked="" type="checkbox"/>
Hide Icon Labels	 With Labels	 Without Labels
Show Icon Showdowns	 Without Shadow	 With Shadow
Enlarge Icons	 Small Icon	 Large Icon

Restart Launcher

The Home Screen is an application called Launcher. If the Home Screen stops responding, Restart Launcher will close and then reopen the Home Screen. When you restart the Launcher, it does not affect the Home Screen appearance settings.

- 1 Press the Home button.
- 2 Press the Menu button.
- 3 Select Restart Launcher.

Restoring the Default Home Screen Setup

You can return the Home Screen to the factory default configuration. This is the configuration you saw when you first used the software.

- 1 Press the Home button.
- 2 Press the Menu button.
- 3 Select Restore Defaults.
- 4 Select OK when the Restore Defaults dialog appears.

About 3M Launcher

This opens the About 3M Launcher screen which displays the software version and copyright information.

App Launcher

The App Launcher is located at the bottom-center of the Home screen. When opened, the App Launcher screen opens and displays all of the applications installed on the projector.

To view all the applications installed on the projector:

- 1 Select the App Launcher. The App screen appears.
- 2 View the applications installed on the projector and select an application to launch it.

Menus

The menus provide additional options for screen, application, settings or items on the screen.

Options Menu

The options menus provide access to additional tasks related to the current screen. Press the Menu Button to view menu. Some screens may not have a menu such the Settings screens.

Opening an options menu: When viewing a screen or application, press the Menu button. The options menu will appear at the bottom of the screen.

Close an option menu: While the options menu is open, press Menu and the options menu will close.

Context Menu

The context menu provides additional options for a specific item the screen. For example, you can select a file from a list in the video play and press Menu and the delete option will appear.

Notifications

Icons that appear in the Notifications area of the status bar make you aware of events occurring in the background. Notifications will appear when:

- a new video device is connected or
- the SD card is inserted.

Opening the Notification Panel

- 1 Press the Home button.
- 2 Press the Menu button.
- 3 Select Notifications. The Notifications panel displays.

Respond to Notifications

- 1 Open the Notification panel.
- 2 Select the notification and the Notification panel closes and depending on the application – a new screen or dialog may appear.

Clearing Notifications

This will clear all inactive notifications.

- 1 Open the Notifications panel.

- 2 Select Clear at the top-right of the panel. All active notifications will remain.

Closing Notifications

Press the Back button

Onscreen Keyboard

You can enter text using the onscreen keyboard. Some applications open the keyboard automatically (such as the Search app), but others require you to select a text field. When the keyboard opens, the Touch Sensor automatically switches to Mouse mode. When you exit the keyboard, the Touch Sensor will return to its previous mode.

Selecting a Text Field

- **Mouse Mode:** Using the Touch Sensor, position the mouse pointer over the text field. Press the Touch Sensor and the onscreen keyboard will display.
- **Trackball Mode:** Using the Touch Sensor, highlight the text field. A red border around the text field and a cursor will appear. Press the Touch Sensor to open the onscreen keyboard. The Touch Sensor will automatically switch to Mouse mode while the onscreen keyboard is displayed.

Typing into Text Field

- 1 Select a text field.
- 2 Using the Touch Sensor, move the mouse pointer over a letter and press the Touch Sensor to type text.
- 3 While you type, suggestions will appear below the text entry field.

Using the Suggestions While You Type

The suggestions offered by the onscreen keyboard are based on the keyboard context.

- If you press the Search button and the keyboard displays, the suggestion will be names of files and folder located on the projector or SD card.
- If you select a text field in a dialog or app, the suggestion will come from the dictionary.

Whether the word you type is in the dictionary or not, the onscreen keyboard will try to make suggestions.

- 1 The first suggestion is the original text that you typed. The bold, orange word will be entered when you type a space or punctuation mark.
- 2 Select one of the suggestions and the underlined word in the text field will be replaced by it.
- 3 When you press the spacebar, the suggestion bar will offer some common punctuation marks.

Entering New Words into the Dictionary

The onscreen keyboard makes suggestions based on words stored in the dictionary. You add new words to the dictionary as follows:

- 1 Type a word.
- 2 Move the mouse pointer over the word in the suggestions area.
- 3 Press and hold the Touch Sensor until the text is no longer underlined. The next time you type, the word will show up as a suggestion.

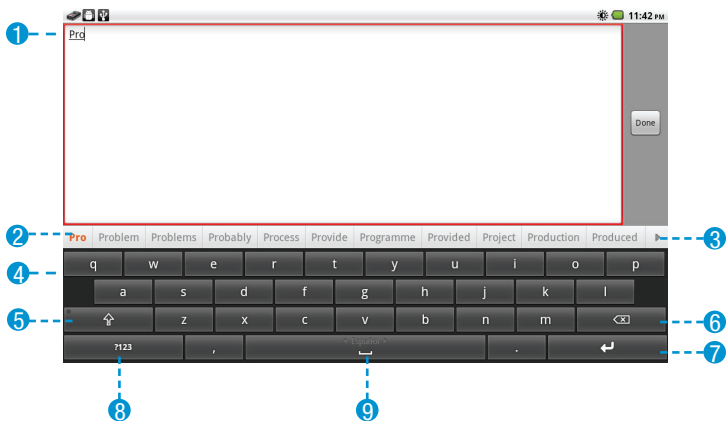

- 1 Text Entry Area
- 2 Suggestions
- 3 Scroll Arrows
- 4 Keyboard
- 5 Shift and Caps Lock
- 6 Delete
- 7 Done
- 8 Numbers and Symbols
- 9 Space/ Language Selection

Entering Numbers and Symbols

Select the Numbers and Symbols key and the keyboard will switch to number and symbols. Press the Alt key to display addition symbols.

Entering Accented and Alternate Letters

Move the mouse pointer over the letter and press and hold the Touch Sensor. A context menu will display the accented or alternate letter available. Type the letter by moving the mouse pointer over the letter and pressing the Touch Sensor.

Accented and Alternate Letters

Accented and alternate letters display when you move the mouse point over the letter and then press and hold the Touch Sensor.

Shortcut for Entering Commonly Used Punctuation and Symbols

Press and hold the “.” period key and a context menu displays with other punctuation marks and symbols. Select one and it will be entered into the text field.

Changing the Keyboard Language

You can change the keyboard language using the spacebar. You select the language you want to use in the Input Languages selection in the Language & keyboard Settings.

- 1 Position the mouse pointer over the spacebar.
- 2 Press down and slide your finger across the Touch Sensor. You will see the new language coming from the left or the right. Make sure the new language is centered on the space bar before releasing the button.

Remote Control (Optional Accessory)

The Remote Control for the 3M MP220 projector controls the projector's screens as well as volume level on the projector, and video and audio playback.

Note: The remote control cannot be used for some operations such as typing on the onscreen keyboard.

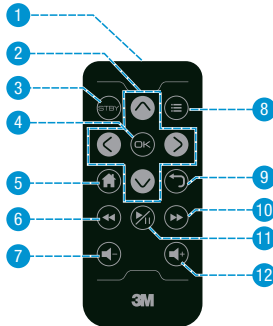

Button Descriptions

- 1 Infrared LED** – Transmits remote control commands to projector.
- 2 Arrow Buttons** – Moves selector or cursor on the screen.
- 3 Standby** – Turns the projector's lamp off or on.
- 4 OK Button** – Press to select or click an item.
- 5 Home Button** – Press to open the Home screen. Press and hold to open recently used applications.
- 6 Rewind** – Rewinds video and music during playback.
- 7 Volume Down** - Decreases the audio volume.
- 8 Menu Button** – Press to open the menu for the current screen or application.
- 9 Back Button** – Press to open previous screen or closes onscreen keyboard.
- 10 Fast Forward** – Advances video music playback.
- 11 Play/Pause** - Start or Pause video or music playback.
- 12 Volume Up** – Increases the audio volume.

Remove Protective Film

Before you can begin using the battery, you must remove the protective film from the battery compartment. Remove the film as shown below.

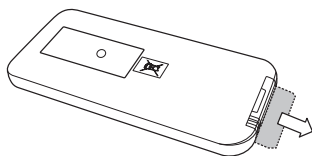

Using the Remote

When using the remote control, point the remote control's infrared transmitter at the receiver on the projector. The receiver is beside volume up button.

Note: Sun light and some indoor lighting may reduce the range of the remote control.

Replacing the Remote Battery

Replace the battery in the remote control with a CR2025 battery.

- 1 Remove the battery and battery tray by holding latch toward the center of the tray and then pull the tray out of the remote control.
- 2 Place the new battery into the tray and orientating the battery positive size (+) as indicated on the tray.
- 3 Finally Slide the tray into the remote Control.

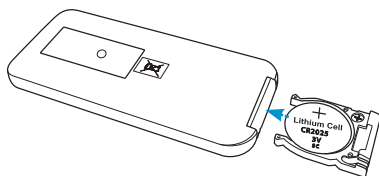
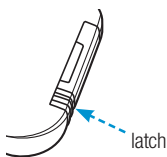

Search

The Search app performs a text search for folder, files, and applications. At the bottom of the text entry box, a list of folders with the files that match, files that match and applications with names that match will appear. The search button opens the Search app and then you can enter search text. Select the file or application you wish to open.

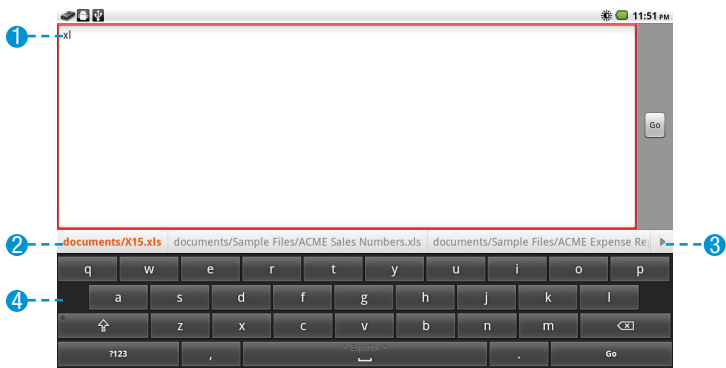

- 1 Text Entry Box
- 2 List of results
- 3 List Scroll Arrows
- 4 Keyboard

Searching for a file or app: Press the Search button and the Search app will appear with a keyboard.

When the Search app appears, the Touch Sensor automatically switches to Mouse mode for use with the keyboard.

Viewing more results: On either side of the results list, there are arrows. Press the arrow and the next set of results will slide into view.

Search Settings

Your search results will contain applications or files. When you select an item from the list of results, it is saved as a shortcut. The shortcut will be displayed in the bar below the text entry box.

Filtering Searchable Items: You can narrow your search by removing apps or files from searchable items. Remove the check mark beside the item you do not wish to see in the results.

Clearing Shortcuts: Select Clear Shortcuts and a dialog will appear. Select OK.

Opening and Switching Applications

The App Launcher contains all of the installed applications. You can open the App Launcher from the Home screen by selecting the App Launcher at the bottom center of the screen. When you open an application, it continues to run in the background after you leave it. This allows you to switch between application and return to the previous screen instead of starting over.

For example, you can open a document using Documents To Go™ and then return to the App Launcher and open Video/ VGA Pass Through. While you are viewing VGA Pass Through, you can quickly switch back to the opened document.

Note There is no need to exit applications because the projector's operating system manages the applications running in the background so that they do not consume resources unnecessarily.

Open and Close the App Launcher

Select the Launcher Icon from the Home screen to open it.

Adding an application to Home screen from Launcher:

- **Mouse Mode:** Move the Mouse pointer over the application icon and press and hold the Touch Sensor. The screen will switch from the Launcher screen to the Home Screen. Move your finger across the Touch Sensor and position the icon where you want it on the Home screen.
- **Trackball Mode:** Not available.

Opening an application: Select an application icon on the Launcher.

Switching to a recently used application: Press and hold the Home button. A window will appear showing all recently used applications. Use the Touch Sensor to select the application or press the Back button to return to the current screen.

Transferring Files to the Projector

The MP220 has both built-in memory and a removable microSD™ card where you can place files. You can put files on the 3M MP220 projector using a USB connection, or you can transfer files to a microSD card prior to inserting it into the MP220. The following sections cover transferring files using a microSD card or a USB connection.

Note: *The projector cannot transfer files from the microSD card to the projector's internal memory.*

Using the microSD Card Slot

The 3M MP220 projector has a microSD card slot that supports SDHC and can read up to a 32 GB card. You can either place files on the card before you insert it into the projector's card slot or while the projector is connected to a USB port on a computer. The projector must access (or mount) the file system on the SD Card after a microSD is inserted.

TIP: *Use a microSD card class 4 or higher for best performance.*

Inserting the microSD Card

- 1 Open the microSD slot door.
- 2 Insert the microSD card into the microSD slot until it “clicks” into place.
- 3 Close the microSD door.
- 4 If the projector is on, it will mount the SD card and scan the files.

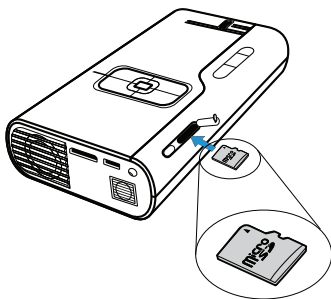

Notification Related to microSD Card

The following icons are notifications you will see when inserting or removing a microSD card.



The microSD card is installed and the system preparing it for use.



The system is scanning the microSD card for media files.



The microSD card was unexpectedly removed.



The microSD card Remove SD card please insert a new one.

Removing the microSD Card

Before removing the microSD card, the projector must be told to unmount the card. You will use the SD card & Local Storage Settings screen in Settings to unmount the card.

Unmount microSD card:

- 1 Press the Home button.
- 2 Press the Menu button.
- 3 Select Settings.
- 4 Select SD card & local storage.
- 5 Select Unmount SD card and select OK in the Unmount SD card dialog.
- 6 A SD card safe to remove notification will appear in the status bar. Now the SD card is ready for removal. See Ejecting the microSD Card for instructions.

Ejecting the microSD Card

- 1 Open the microSD slot door.
- 2 Push the microSD card into the microSD slot until it “clicks”.
- 3 Release the microSD card and the card will eject.

Using the USB Port

The MP220 has a USB connection located at the rear of the projector. You can connect the MP220 projector to a computer and the computer can open both the MP220 internal memory and microSD card like a disk drive.

Types of devices that may transfer data to the projector:

- Computers
- Netbooks
- Tablets

Troubleshooting: If your computer is running Microsoft Windows, the USB Flash drive may not be available on your computer's Windows Explorer. Please refer to KB297694 on the Microsoft support website.

Transfer Files Using USB

- 1 Turn on the projector.
- 2 Connect the USB cable to the projector.
- 3 Connect the USB cable to the computer. The projector screen will display the USB Mass Storage screen
- 4 Select the Turn on USB Storage button and the USB Android icon will turn red.
- 5 Select OK when the Turn on USB storage dialog appears.
The projector will be detected as a removable drive labeled "Internal" by the computer. The drive labeled "Internal" is the projector's on-board memory, and "Removable Disk" is the microSD card installed into the projector. Note that the first time you connect your projector to a computer, it may take the computer some time to detect and install drivers for reading the memory on the projector.
- 6 The projector is now ready to receive a file from your computer.

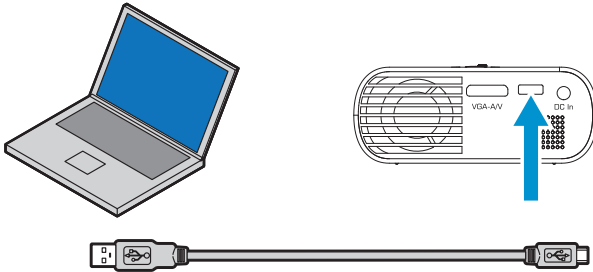

Disconnecting the Projector from the Computer USB Port

Before you disconnect the USB drive from the device's USB port, you must properly eject the removable drives on your computer or you may lose data.

Eject both removable drives on your computer operating system, as follows:

Eject a drive on computers running Microsoft Windows: Open Windows Explorer, right-click the drive, and click Eject from the context menu.

Eject a drive on a computer running Apple Mac OS 10: Open finder, choose the drive, and then choose File>Eject.

Video/VGA Pass Through

The Video/VGA Pass Through application manages the VGA-AV port on the projector. When you connect a video cable into this port, the application will recognize it and open. Once open, the application will either display the video or VGA image or a status message.

Opening and Exiting VGA Pass Through

Video/VGA Pass Through will open automatically when a cable is plugged into the VGA-AV input on the project. If the projector detects a video or VGA, it will project it by default. If you want to acknowledge the input before it is projected, you can deselect DirectConnect option in the Preferences within the Video/VGA Pass Through application.

Open Video/VGA Pass Through: Plug a cable into the VGA-A/V port on the projector or select the app icon in App Launcher.

Exit Video/VGA Pass Through: Select the Exit button on the message screen or press the Home button

Notifications

The Video/VGA Pass Through will report changes using notification when the application is not displayed on the screen. When you select the notification, it will open the application.

Freeze Video Image

You can freeze (or pause) the image while an input source is connected. When the image is frozen, changes in the image coming from your computer or video device will not be displayed.

Freezing the Image: Press Menu and then select Freeze.

UnFreezing the Image: Press Menu and then select Live.

Mute Audio

You can mute the audio using Mute in the options menu.

Muting the Audio: Press Menu and then select Mute.

Unmuting the Audio: Press Menu and then select Unmute.

Blank Image

You can blank the image while a video input is playing.

Blanking the Image: Press Menu and then select Blank. A blue screen will appear.

Resume the Image: Press Menu and then select Resume.

Image Capture

The Video/VGA Pass Through application can capture paused video and computer images. When an image is captured, the image is saved into the /DCIM/Camera folder on the projector's onboard memory.

To capture an image: Press Menu and then select Capture. A message appears when the image capture is complete.

Note: If you get a Save Failed message, the projector's memory is being scanned or the microSD card is not mounted.

Settings

These settings let you change how you view the video image coming from a video source. The projector displays a WSVGA image (or 1024x600 pixels) which is a 17:10 image.

Signal Aspect Ratio

Change the aspect ratio (width versus height) of the image. When you choose one of the aspect ratios, the image is stretched or shrunk to that aspect ratio.

- Default – Aspect Ratio setting for the input resolution
- 4:3 – Scales the image to a 4:3 aspect ratio
- 16:9 – Scales the image to a 16:9 aspect ratio
- Native – Aspect Ratio scales the image to the projector native Aspect ratio, 17:10

Letterbox Cropping

Crops or cuts the image down to the specified aspect ratio.

Edge Cropping

This is similar to over scanning. Some older videos have noise along the edges of the image. You use edge cropping to hide that noise.

Display Scaling

Scales the image to fit width, height, or both. Display scaling even displays the native resolutions.

Making Connections

The 3M MP220 projector will display informational icons depending on the input device and signal being detected. If no devices or input cables are connected to the projector, the Home screen will display. The 3M MP220 was designed to operate with 3M VGA and AV cables only.

Tip: The video output on some devices is turned off by default. Please refer to the device's documentation for details on enabling the video output.

Connecting to a Composite Video Device (requires optional accessory)

For standard (composite) video input, you must purchase the optional 3M MP220 Composite AV Cable. Use the composite AV cable to input video from camcorders, digital cameras, DVD players and digital media players into the VGA-AV input on the projector.

- 1 Connect the AV cable to the projector's VGA-AV input.
- 2 Connect the other end of the AV cable to the video device's audio and video outputs.

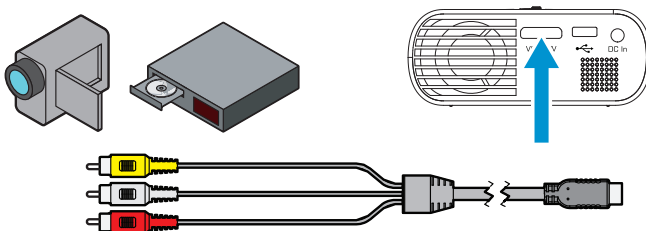

Tip: Some video devices do not have the standard audio and video connections and may require an AV cable specified by the manufacturer. The AV cable allows you to connect your video device to your TV monitor or your projector and may be purchased from the video device manufacturer. Once you have the AV cable, use the cable adapters to connect the video device cable and the projector cable.

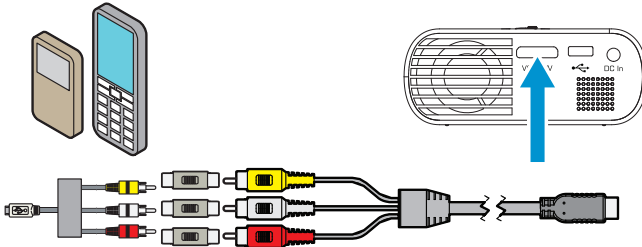

Connecting to a Component Video Device (requires optional accessory)

For component video input, you must purchase the optional 3M MP220 Component AV Cable. This cable sends a higher quality video signal for the best possible image.

- 1 Connect the component AV cable to the projector's VGA-AV input.
- 2 Connect the other end of the AV cable to the video device's audio and video outputs.

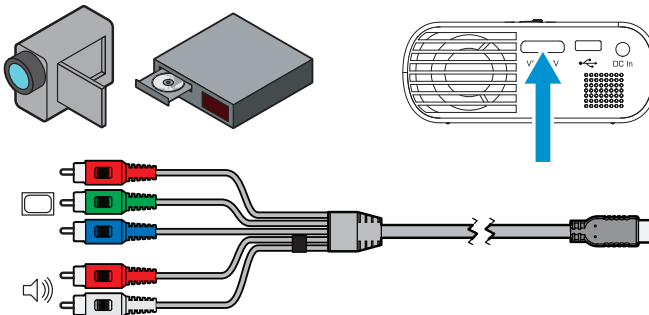

Important Note: There are two red connectors on the Component AV cable. One is for the right audio channel and the other is for the Pr component video signal. Be careful to connect the red audio to red audio and red video to red video. If these connectors are switched, the projected image will appear green and an abnormal noise will come from the right speaker.

Tip: Some video devices do not have the standard audio and video connections and may require an AV cable specified by the manufacturer. The AV cable allows you to connect your video device to your TV monitor or your projector and may be purchased from the video device manufacturer. Once you have the AV cable, use the cable adapters to connect the video device cable and the projector cable.

Some video devices, by default, will not output a video signal. The video device's manual should provide instructions on how to change the video output setting.

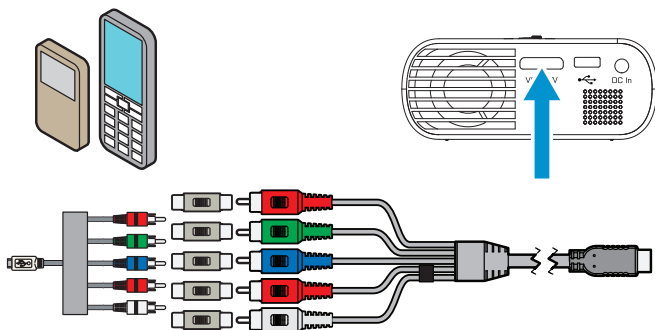

Connecting to a Computer (requires optional accessory)

For VGA-audio input, you must purchase the optional 3M MP220 VGA-audio Cable. Use the VGA-audio cable to connect the projector to home screen computers, laptop computers, ultra-portable computers and some personal digital assistants (PDAs). The projector supports VGA, SVGA, XGA, and WXGA resolutions. For best results, set the computer's resolution to WXGA (1024x600).

- 1 Connect the VGA-audio cable to the 3M MP220 projector.

- 2 Connect the VGA-audio cable to the computer's video and audio outputs.
- 3 Set the computer resolution to one of the supported resolutions.

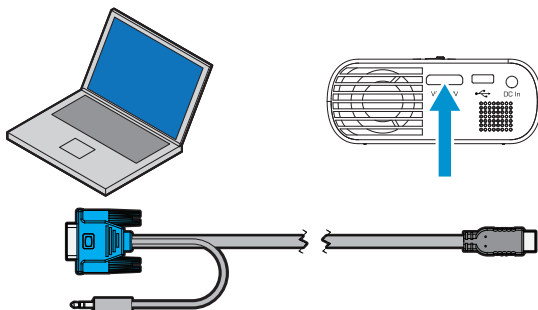

Description	Resolution (width x height)	Refresh Rate
VGA	640 x 480	60 Hz
SVGA	800 x 600	60 Hz
XGA	1024 x 768	60 Hz
WXGA	1280 x 768	60 Hz
	1366 x 768	60 Hz
	1024 x 600	60 Hz
	1280 x 960	60 Hz
MAC	1440 x 900	60 Hz
	640 x 480	67 Hz
	832 x 624	75 Hz
	1152 x 870	75 Hz

Gallery

You can use the Gallery to view pictures that you've downloaded onto the projector's internal memory or the SD card. You can also perform basic photo editing and set use the photo as your Home screen wallpaper.

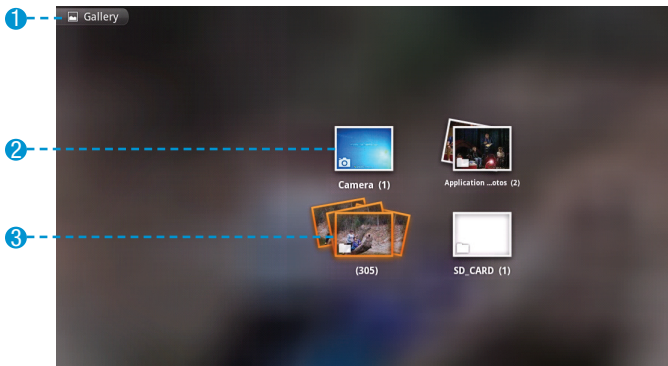

- 1 Current Open Folder
- 2 Photos taken with the Video/VGA Pass Through application.
- 3 Photos in a Folder/Album

Note: Video will not appear in Gallery. If you want to view a list of videos or play a video you need to use Video Player.

Opening Gallery

Open Gallery to view albums (or folders) of your pictures:

- 1 Select Gallery from App Launcher or your Home Screen.
- 2 Once open, Gallery displays pictures from the project's internal memory and SD card. Gallery may take seconds to a few minutes to display your entire album depending on the amount of photos.

Picture Albums

Albums are folders containing pictures that are located on the projector's internal memory and SD card.

Opening an Album and Viewing Its Contents

- 1 Open Gallery.
- 2 Select the Album that contains pictures you want to view. The screen will display pictures in a chronological ordered grid. The Album name will appear at the top of the screen.
- 3 Select the photo you want to view.

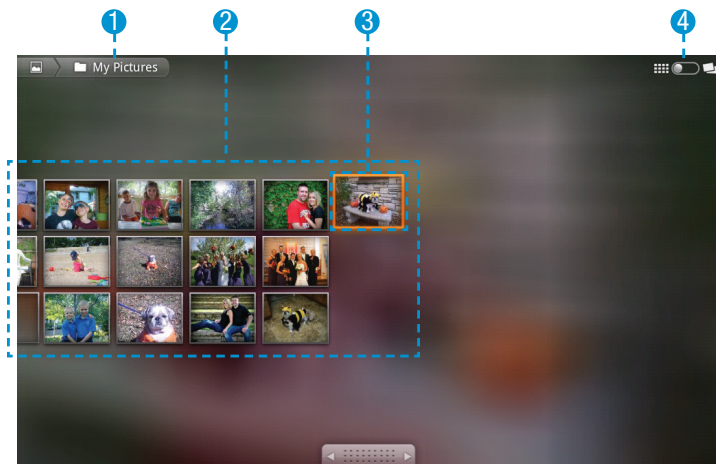

- 1 Name of Album
- 2 Picture Thumbnails
- 3 Highlighted Picture
- 4 Grid/Stack View switch

Changing How the Contents of an Album Are Displayed

There are two ways to view pictures in Gallery:

- Chronological grid, or
- Stacks.

The pictures are sorted by date in both views.

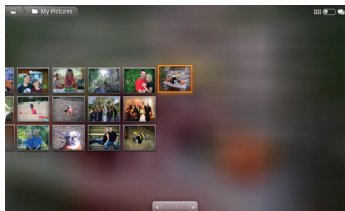

Grid View

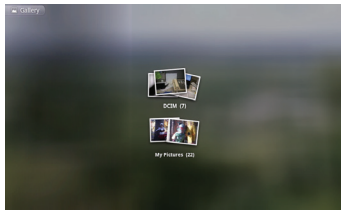

Stack View

Switching between Grid and Stack views:

- 1 Select an Album.
- 2 Move the mouse pointer to the Album View switch.



- 3 Press the Touch Sensor.
- 4 Move the switch to change the view to either grid or stacks view.

Note: If you don't see the mouse pointer, switch mouse modes. For more detail on switching the mouse modes, see [Switching Between Mouse and Trackball Mode](#).

Getting Details about an Album

- 1 Press the Menu button twice.
- 2 Place a checkmark on the albums you want details about.
- 3 Select More and a menu appears.
- 4 Select Details and a dialog will appear.

Deleting an Album

You can delete the entire album and all of its contents from internal memory or the SD card.

- 1 Press the Menu button twice.
- 2 Place a checkmark on the albums and files you want to delete.
- 3 Select Delete and a confirmation dialog will appear.
- 4 Select Confirm Delete. Select Cancel if you do not want to delete the albums and files.

Pictures

Use the Gallery to view picture(s) on the internal memory and the SD card. You can view, edit, or delete these pictures.

Viewing and Browsing Pictures

- 1 Open Gallery.
- 2 Open an album.
- 3 Select a picture.

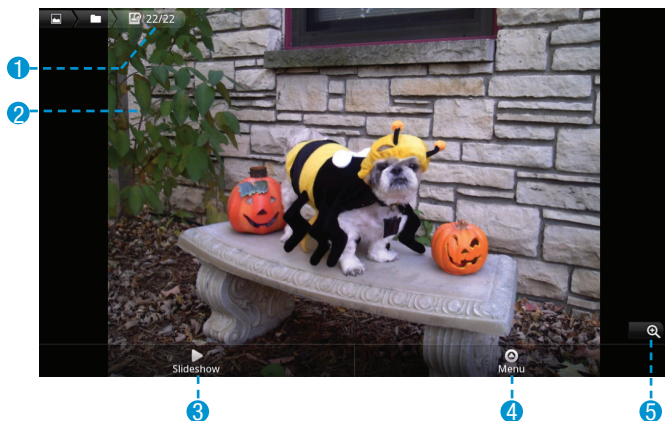

- 1 Album Location

- 2 Picture
- 3 Start Slideshow
- 4 Menu
- 5 Zoom controls

Opening Controls

If the controls are not visible while viewing a picture, press the Touch Sensor.

Select One of the Controls or Its Menus

- **Mouse mode:** Move the mouse pointer over the control and press the Touch Sensor.
- **Trackball mode:** After the control opens, move your finger from top to bottom on the Touch Sensor and select control highlight.

Scrolling Through the Pictures

To scroll through the pictures in an album:

- **Mouse Mode:** In one motion, press and swipe your finger from across the Touch Sensor from right to left to reveal the next picture in the album or folder. Swipe your finger left to right to reveal previous picture in the album or folder.
- **Trackball Mode:** Move your finger across the Touch Sensor in the direction you want to scroll the page.

Working with Pictures as a Group or Individually

You can work with a group of pictures or work with pictures individually. You can perform the following actions on pictures:

- Get details,
- Delete,
- Rotate clockwise or counterclockwise,
- Set as wallpaper or
- Crop.

To select the album(s) or picture(s) you want to work with:

- 1 Open the album to view the pictures you want to work with

- 2 Open the Gallery Menu
 - If a picture is highlighted already, press Menu once.
 - If a picture is not highlighted, press Menu twice.
- 3 Place a checkmark on each picture you wish to work with.
 - **Mouse Mode:** Move the mouse pointer over the picture and press the Touch Sensor
 - **Trackball Mode:** Use the Touch Sensor to move the highlighter over the picture and press the Touch Sensor.

Note: You can press the Touch Sensor again to deselect (uncheck) the picture.

Getting Details About a Picture

- 1 Select a picture.
- 2 Open the controls.
- 3 Select More.
- 4 Select Details. A dialog will appear with the file title, type, date, album location, and GPS location.

Rotating Pictures

- 1 Select the picture and open the control.
- 2 Select More and a menu opens.
- 3 Select either Rotate Right or Rotate Left. The picture will automatically save in the new orientation.

Zooming a Picture

Quick Zoom In and Out

- **Mouse Mode:** Move the mouse pointer over area you want to zoom into and quickly press the Touch Sensor twice (also known as a double click). Double click again to zoom out.
- **Trackball Mode:** Press the Touch Sensor to zoom in and press the Touch Sensor again to zoom back out.

Zoom In and Out Using the Plus and Minus Magnifying Glass

- **Mouse Mode:** Press the Touch Sensor to display the controls. Move the mouse pointer over the – or + magnifying glass button and press the Touch Sensor.

Panning a Zoomed Picture

- **Mouse Mode:** Once you zoomed in a picture, press and swipe your finger from across the Touch Sensor you want to pan the picture.
- **Trackball Mode:** Once you zoomed in a picture, move your finger across the Touch Sensor in the direction you want to pan the image.

Watching a Slideshow of Your Pictures

- 1 Select the picture and open the control.
- 2 Select Slideshow. A slideshow will begin.
- 3 Press the Touch Sensor to end the slideshow.

Setting Picture as Wallpaper

You can set a picture as the wallpaper on the Home screen.

- 1 Select a picture from the Gallery.
- 2 Open the control.
- 3 Press Menu button.
- 4 Select More button.
- 5 Select Set as wallpaper. The picture with a cropped area will appear.
- 6 After cropping the picture, select Save. Now the cropped picture will appear on the Home screen.

Cropping Pictures

You can crop pictures and save the cropped portion of the picture to a file.

You can only crop using Mouse Mode.

- 1 Press the Touch Sensor on a picture to open the controls.
- 2 Select More.

- 3 Select Crop. The cropping rectangle appears on top of the picture.
 - To move a cropped area, move the mouse pointer to the center of the area and press and hold the Touch Sensor. Move your finger on the Touch Sensor to move the cropped area.
 - To increase or decrease the horizontal size, move the mouse pointer near the orange, vertical lines and press and hold the Touch Sensor. Move your finger to the right and left to change the size of the cropped area.
 - To increase or decrease the vertical size, move the mouse pointer near the orange horizontal lines to change the size of the cropped area.
- 4 Select Save. The projector will save a copy of the cropped picture.

Delete a Picture

You can delete a picture from the projector's internal memory or the SD card.

- 1 Open the controls
- 2 Press the Menu button
- 3 Select Delete and OK in the confirm delete dialog.

Music

You can organize and listen to music stored on the projector's internal memory or SD card.

Transferring Music Libraries

Music utilizes the same file and folder structure as many media player applications for your computer. In most cases, you should be able to copy your song libraries and playlist onto the projector's memory or SD card.

Music searches the projector's internal memory and SD card for supported audio files and playlists. The supported audio formats are: MP3, M4A, AMR, MIDI, and OGG Vorbis. It does not support audio files that contain DRM (Digital Rights Management).

Once Music finds audio files, it looks for:

- The folder containing the songs and uses the folder's label as the album name.
- A folder containing the album folder and uses the folder's label as the artist name.
- Album art. The album art work must be in the same folder as the music and be labeled "albumart.jpg".

For best performance, place your music library into one folder such as a folder labeled "Music" or "My Music". For information about transferring files to the projector, see [Transferring Files to the Projector](#).

Opening Music and Working with Your Music Library

After you have copied your music to the projector, you can open Music and see your library of music files. You can view your music files sorted either by Artist, Albums, Songs, or in Playlist. The main screen for Music is called the Library.

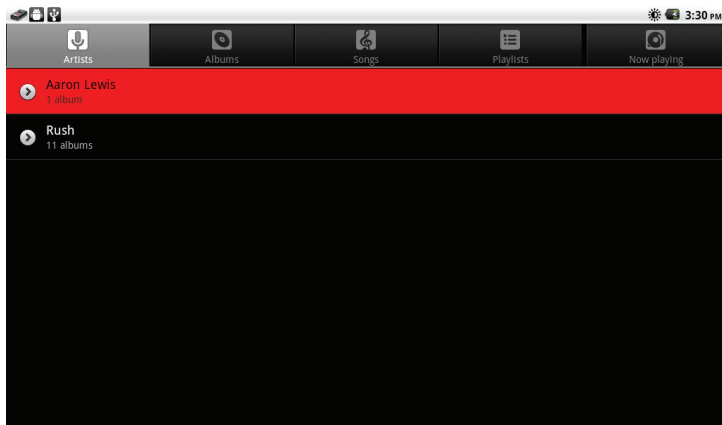

Opening the Music Library

You can open the music library in one of two ways:

- Press the Home button, select the Media tab, and then select Music.

or

- Press the Home button, select the App Launcher and then select Music.

Note: When Music opens, it catalogs your audio files. The more audio files; the longer it will take MUSIC to open. Most of the time, Music will open within a few seconds.

Return to the library from any Music Screen: Press the Menu button and then select Library or press the Back button.

Searching for a Artist, Album or Song

- 1 Begin the search:
 - **Mouse Mode:** Select the sorted list you want to search.
 - **Track Mode:** Highlight the sorted list you want to search and then move the highlighter down into the list.
- 2 Press and hold the Menu button.

- 3 Use the keyboard to type in your text search.
- 4 Select Done. A list of results displays.
- 5 Press the back button to clear the results

Deleting a Song

When you delete a song, it is permanently removed from the projector or the SD card.

Delete a song while in the library screen:

- **Mouse Mode:** Move the mouse pointer over the song. Press and hold the Touch Sensor and the album context menu will appear. Select Delete and then select OK in the delete confirmation dialog.
- **Trackball Mode:** Select a song. Press and hold the Touch Sensor and the album dialog will appear. Select Delete and then select OK in the delete confirmation dialog.

Delete a song while in the playback screen:

Press the Menu button. Select Delete and then select OK in the delete confirmation dialog.

Playing Music

The MP220 has built-in speakers and headphone jack for listening to music. You can use the Volume + and Volume – buttons to control the audio level (or volume) for both. Music can play:

- a single song,
- an album,
- a playlist of songs or
- randomly shuffle songs.

Music can play songs while the projector's lamp is off or while you are using other applications.

Play a song from the Library: Select the song and the playback screen will appear. The song will begin to play.

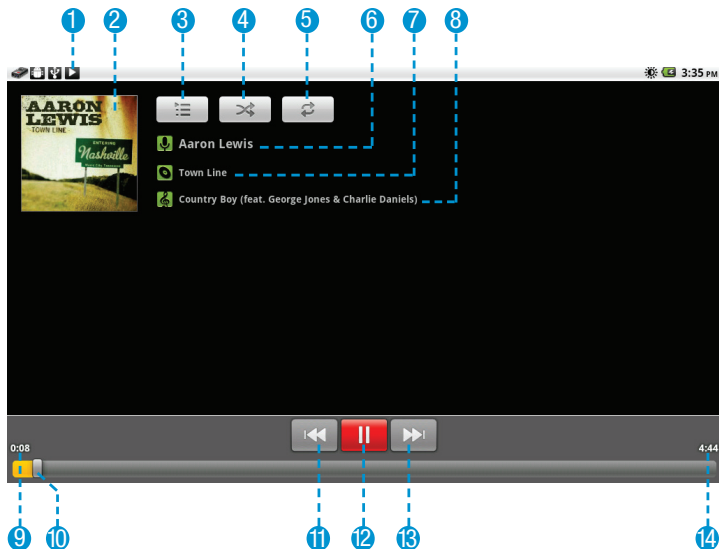

- 1 Now Playing
- 2 Album artwork
- 3 Now Playing List
- 4 Shuffle All
- 5 Repeat Current or Repeat All Songs
- 6 Artist
- 7 Album
- 8 Song
- 9 Play time
- 10 Playback Progress Slider
- 11 Previous Song
- 12 Play/Pause
- 13 Next Song
- 14 Song Time

Opening or Returning to the Playback Screen

The Playback screen automatically opens when you select a song to play. You can leave the Playback screen without affecting the song playback by pressing the Home button or Back button.

Return to the Playback Screen Using Mouse and Trackball Mode

- 1 Press the Home button.
- 2 Press the Menu button.
- 3 Select notifications.
- 4 Select the song and the Playback screen will open.

Return to the Playback Screen While in the Music Library (Mouse Mode only)

While the Music is on the screen, select the Now Playing tab.

Play All Songs in an Album

- 1 Select the Albums tab in the Library screen.
- 2 Select the album and a list of songs within the album will appear.
- 3 Press the Menu button and select Play all. Music will start playing all of the songs in the album starting with the first song in the list. Music will stop when it reaches the end of the album or when you stop playback.

Repeat a Song or All Songs

While the Playback screen is open, select the Repeat Button to toggle through the repeat options.



Repeat All



Repeat only the Current Song



Repeat is off

Shuffle Currently Playing Playlist or Album

Select the Shuffle button to turn it on or off. Shuffle plays the current playlist or album in random order.



Shuffle on



Shuffle off



Party Shuffle is on

Party Shuffle

Music plays all music on the projector (internal and SD card) in random order when Party Shuffle is on.

Turning Party Shuffle on: Press the Menu button. Select Party Shuffle and Party Shuffle will turn on or off.

Viewing the current Party Shuffle playlist: In the Playback screen, select Now Playing button and the Now Playing screen will appear. Party Shuffle starts with six songs on the playlist and then adds one more after each song in the playlist ends.

Saving the Party Shuffle playlist as a new playlist: While in the Now Playing screen, press the Save as playlist. Type a name for the new playlist using the onscreen keyboard and select Save.

Adding a Song to the Party Shuffle Playlist

- **Mouse Mode:** Move the mouse pointer over the song in the list. Press and hold the Touch Sensor and the album context menu will appear. Select Add to playlist and then select Current playlist.
- **Trackball Mode:** Select a song. Press and hold the Touch Sensor and the album context menu will appear. Select Add to playlist and then select Current playlist.

Playlists

Playlist helps you organize your favorite music into sets song, which you can play in the order you set or in a shuffle.

Creating a Playlist

To create a playlist:

- 1 Add songs to a new playlist.

- **Mouse Mode:** Move the mouse pointer over the song. Press and hold the Touch Sensor and the album context menu will appear. Select Add to Playlist. Repeat these steps to add additional songs to the playlist.
 - **Trackball Mode:** Select a song. Press and hold the Touch Sensor and the album dialog will appear. Select Add to Playlist. Repeat these steps to add additional songs to the playlist.
- 2 When you are finished adding songs, select New from the Add to Playlist context menu.
 - 3 Type the name of the new Playlist using the onscreen keyboard.
 - 4 Select Save.

Add a Song to a Playlist

- 1 Select the playlist name.
- 2 Add songs to the playlist.
 - **Mouse Mode:** Move the mouse pointer over the song. Press and hold the Touch Sensor and the album context menu will appear. Select Add to Playlist. Repeat these steps to add additional songs to the Playlist.
 - **Trackball Mode:** Select a song. Press and hold the Touch Sensor and the album dialog will appear. Select Add to Playlist. Repeat these steps to add additional songs to the Playlist.
- 3 Select Save.

Remove a Song from a Playlist

- 1 Open a playlist.
- 2 Remove the song
 - **Mouse Mode:** Move the mouse pointer over the song. Press and hold the Touch Sensor and the song context menu will appear. Select Remove from Playlist.
 - **Trackball Mode:** Select a song. Press and hold the Touch Sensor and the song dialog will appear. Select Remove from Playlist.

Rename or Delete a Playlist

- 1 In the Library screen, select the playlist.
- 2 Rename or delete the playlist:
 - **Mouse Mode:** Move the mouse pointer over the song. Press and hold the Touch Sensor and the song context menu will appear. Select Rename or Delete.
 - **Trackball Mode:** Select a song. Press and hold the Touch Sensor and the song dialog will appear. Select Rename or Delete

Create Playlists on Your Computer

You can use playlists you have created on your computer in MUSIC. Music supports the following computer playlist formats: M3U, WPL, and PLS. You copy your playlist file onto the projector's internal memory or SD card in the same folder or directory as the music.

You can create a playlist using a text editor program using the following guidelines:

- Enter each song file name that you want in the playlist.
- Save the file with a M3U extension. For example, myplaylist.m3u.

Video Player

The Video player plays video stored on the internal memory and SD card. You can control the video playback and repeat a video. When you open Video Player, Video Player searches for supported video files and displays them in a list.

The Video Player supports the following file extensions, video and audio codecs and resolutions.

Video File Support*: mp4, m4a, m4v, mov, avi, Xvid, mkv, mka, Xvid, 3gp, 3gpp, 3g2, 3gpp2

Audio File Support*: mp4, m4a, mp3, aac, adif, adts, wav, amr, awb, ogg, oga, mka*

Video Codec Support: MPEG4(SP/ASP), Xvid, DivX 4/5, H.264

Audio Codec Support: MP3, ACC(LC, LTP, HEV1, HEV2), AMR-NB, AMR-WB, MSADPCM, PCM, Vorbis

*The MP220 may not support a specific file, although it is listed, because the video or audio stream embedded into the file is not supported.

List of videos

This screen shows all of the folders or directory where video files are located.

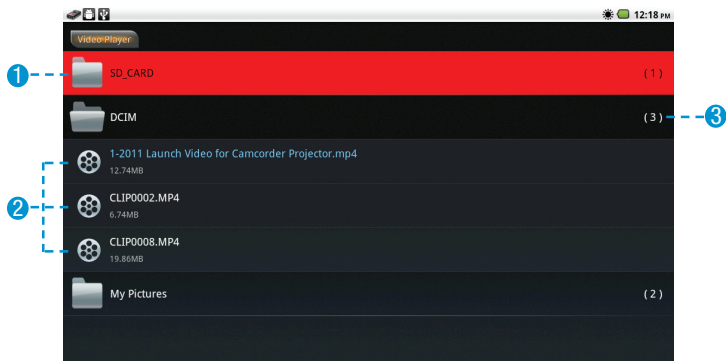

- 1 Root folder for the SD Card (SD_CARD)
- 2 Video files
- 3 Number of video files in folder

Playing Videos

Select one of the video files and the video will start to play. When the play controls disappear, you can press the Touch Sensor to display them again.

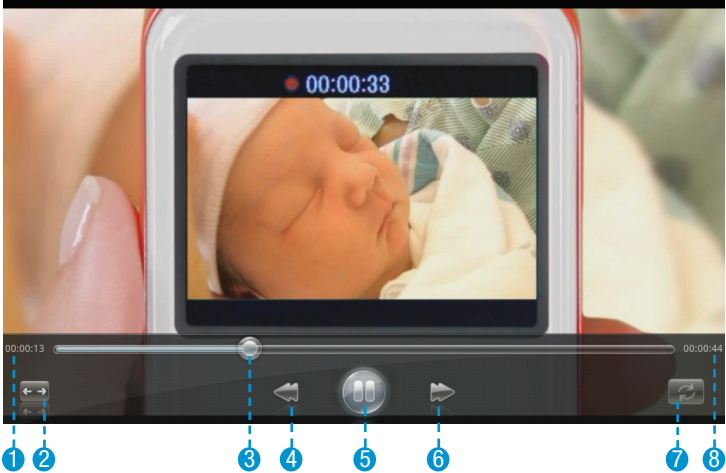

- 1 Play time
- 2 Aspect Ratio Options
- 3 Progress bar
- 4 Rewind video
- 5 Play/Pause
- 6 Fast forward
- 7 Repeat
- 8 Total time

Controlling Video Playback



Rewind - Press to rewind within the current track. Press again to rewind even faster, up to 64 times normal speed. The actual speed is displayed above the play/pause button.



Play/pause - Press to play or pause the current track.



Fast forward - Press to fast forward within the current track. Press again to fast forward even faster, up to 64 times normal speed. The actual speed is displayed above the play/pause button.

Deleting Videos

- 1 While viewing a file list, press Menu
- 2 Select the file or files you want to delete.
- 3 Select the Delete button.
- 4 Select Confirm Delete.

Compatible Video Formats

Video File Support*: mp4, m4a, m4v, mov, avi, Xvid, mkv, mka, Xvid, 3gp, 3gpp, 3g2, 3gpp2

Audio File Support*: mp4, m4a, mp3, aac, adif, adts, wav, amr, awb, ogg, oga, mka*

Video Codec Support: MPEG4(SP/ASP), Xvid, DivX 4/5, H.264

Audio Codec Support: MP3, ACC(LC, LTP, HEV1, HEV2), AMR-NB, AMR-WB, MSADPCM, PCM, Vorbis

*The MP220 may not support a specific file, although it is listed, because the video or audio stream embedded into the file is not supported.

Clock

The clock application not only displays the time but gives you quick access to photo slides, music and alarms. You can also dim the projector while the clock is displayed. After a few minutes the Clock screen will go into screen-saver mode.

Opening the Clock

Select Clock on the Home screen or in the Launcher.

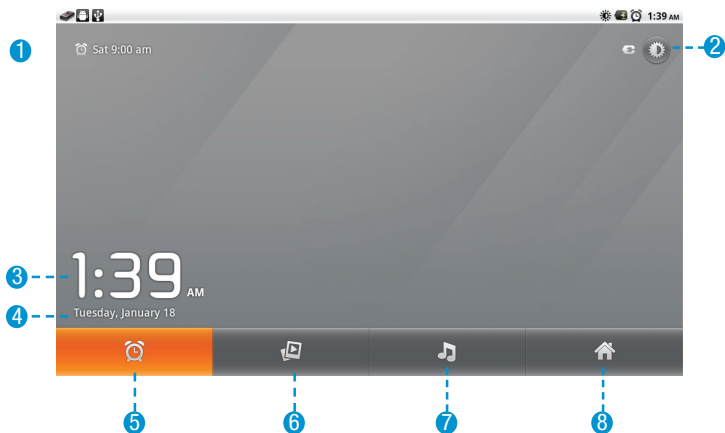

- 1 Next Alarm – The next alarm that will sound.
- 2 Dim – Puts the clock screen into dim mode.
- 3 Time – This is the current system time.
- 4 Date – This is the current system date.
- 5 Alarms – Opens the alarms screen.
- 6 Photo SlideShow – Opens gallery and allow you to start a photo slideshow.
- 7 Music – Open music and allows you to play a song, album or playlist.
- 8 Home – Returns you to the Home screen

Dimming the Clock Screen

Dim the clock screen by selecting the Dim button. Select the Dim button again to return to normal brightness.

Note: Dimming the Clock screen does not reduce the amount of power used by the projector. In turn, it does not save battery power.

Playing a Slideshow

You can replace the Clock screen with a photo slideshow from your Gallery albums.

Start the slideshow: Select the Photo Slideshow button and the slideshow will begin.

End the slideshow: Press the Back button.

Playing Music

You can play music while the Clock screen is displayed.

- 1 Press the Music icon and the Music application opens.
- 2 Select the song, album or playlist.
- 3 After the music begins, return to the Clock by pressing the Back button, pressing and holding the Home button and then selecting Clock.

For more about music, see "Music" on page 63.

Setting the Alarms

You can set an alarm by modifying an existing alarm or by setting a new one.

Opening Alarms

- Select Alarm button at the bottom of the clock screen.
- Press the Menu button and select Alarms from the options menu.

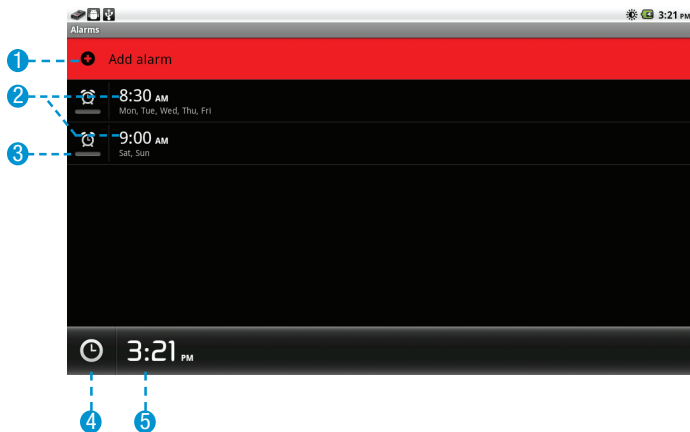

- 1 Add alarm
- 2 Alarms
- 3 Alarm on/off indicator
- 4 Return to main Clock screen.
- 5 Current Time.

Turn an Alarm On or Off

- 1 Select an Alarm and press the Touch Sensor to open Set alarm screen.
- 2 Select Turn alarm on
- 3 Press the Touch Sensor to check or uncheck Turn alarm on.

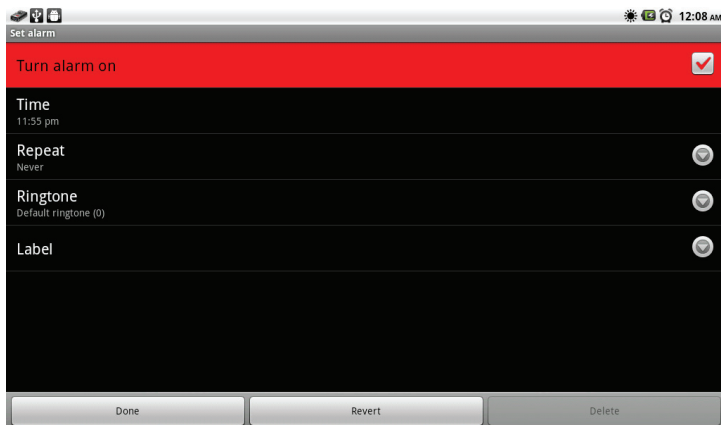

Other Alarm Features

While in the Set alarm screen, you can change the time of the alarm; define how often the alarm goes off; select a ringtone for the alarm; and finally you can label the alarm.

Documents To Go

The 3M MP220 projector comes with Documents To Go standard version.

Documents to Go supports Microsoft® Office files such as:

- Word documents,
- Excel workbooks, and
- PowerPoint slideshows.

This version allows you to view, edit and save files.

Registering Documents To Go and Upgrading to the Full Version



The MP220 does not have a network connection such as Wi-Fi or mobile network. Therefore, you cannot register or upgrade Documents To Go. When you come to the registration screen, select Later.

Documents to Go Home Screen

The Documents to Go Home Screen is the starting point when you launch Documents to Go.

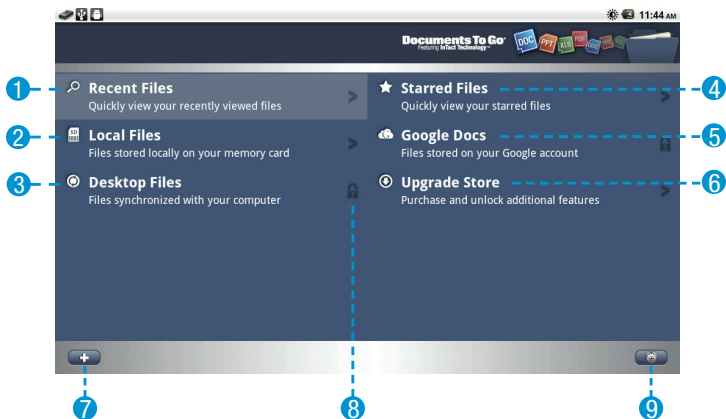
Important Note: The Home Screen Menu options with a lock  next to them are locked and are only available in the Full Version.



- 1 Recent Files – Displays recently viewed files.
- 2 Local Files – List of files located on your projector's internal memory and SD card.
- 3 Desktop Files – Not supported in the standard version.
- 4 Starred Files – Displays all files marked as starred. A star appears to the right of the file. The starred files will appear when viewing the Starred Files list from the Home Screen.
- 5 Google Docs – Not supported in the standard version.
- 6 Upgrade Store – Not supported in the standard version.
- 7 New Document  – Not supported in the standard version.
- 8 Locked Feature  – The standard version has some limitations compared to the Full version. The features that are not available have a lock to the right of them.
- 9 Settings  – About shows the version of Documents To Go. The Register, Check for Updates and Give Us Feedback selections are not supported in the standard version. Only Remember Last Location is supported under Advanced Options. Remember Last Location brings you back to the last file location you were in when you last closed Documents To Go.

Documents To Go Files Screen

After transferring files to the projector's internal memory or SD card, you can locate and manage your files and folders on the Files screen.





- 1 Current Files Screen – Displays the name of the current file screen that you have opened: Recent, Local or Starred.
- 2 Folder Path – Displays the folder path for files which are located in the internal memory or SD card.

Root Directories for the Internal Memory and microSD card:

Internal Memory – /SD Card/

microSD Card – /SD Card/SD_CARD/

- 3 Upper Level Folder – Takes you to the upper level (or parent) folder.
- 4 Selector – Places a checkbox before the files and folders that you want to delete or display information.
- 5 New File – Not supported in the standard version.
- 6 Delete – Deletes all files or folders selected for deletion.
- 7 Information – Displays the selected files or folders properties.
- 8 Send Via Email – Not supported in the standard version.
- 9 Sort – Not supported in the standard version.

- 10 Filter  – Not supported in the standard version.
- 11 Star  – Displays when a file is marked as starred.

Locating a Document, Workbook, or Slideshow File

- 1 From the Documents to Go Home screen, select Local Files. A list of files and folder appears.
- 2 Select the folder that contains the file you are looking for.
 - **Mouse Mode:** Select the folder by pressing the Touch Sensor. The folder opens with a list of files.
 - **Trackball Mode:** Highlight the folder by pressing the Touch Sensor. The folder opens with a list of files.
- 3 If you want to go back one level in the folder structure, select the Upper Level Folder  icon.

Deleting Files or Folders

You can delete one or more files or folders using your Mouse or Trackball.

Delete One File or Folder

- 1 Select the file or folder you want to delete.
 - **Mouse Mode:** Position the mouse pointer over the file or folder name you want to delete.
 - **Trackball Mode:** Highlight the file or folder you want to delete.
- 2 Choose Select.
- 3 Click Delete.
- 4 When the Delete confirmation dialog appears, click Yes. The file or folder is deleted.

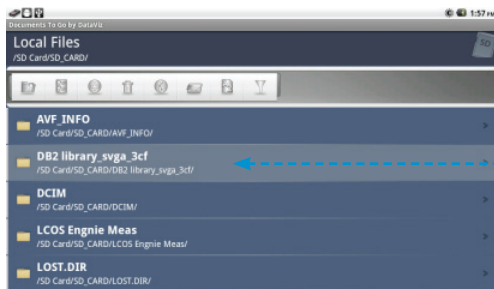

Select the file or folder you want to delete.

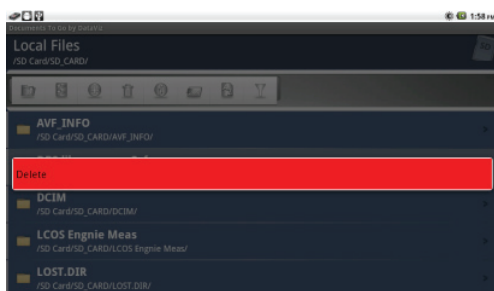

Click **Select** and then click **Delete**.

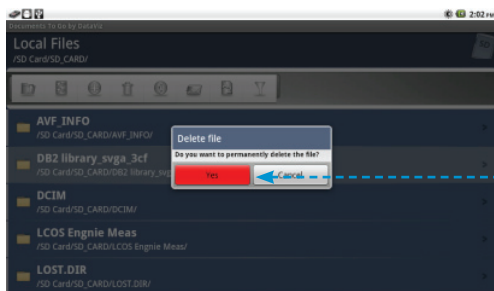

Click **Yes** to confirm the deletion.



The file is removed from the list.

Delete One or More Files or Folders

- 1 Choose Select.
- 2 Place checkmarks next to each file or folder you want to delete.
 - **Mouse Mode:** Position the mouse pointer over the checkmark to the left of the file or folder you want to delete. Press the Touch Sensor to place a check next to the file or folder name.
 - **Trackball Mode:** Highlight the file or folder you want to delete. Move your finger from left to right across the Touch Sensor. A checkmark appears next to the file or folder name.
- 3 Repeat Step 2 for each file and folder you want to delete.
- 4 Click Delete.
- 5 When the Delete confirmation dialog appears, click Yes. The files or folders are deleted.

Starring and Unstarring Files

When you star a file or files, the files appear in the Starred Files screen. Starring makes it quick and easy to access files no matter where they are located. You can also unstar files.

Starring a File

- 1 Select the file you want to star.
- 2 Star the selected file.

- **Mouse Mode:** Position the mouse pointer over the star located in the same row as the filename and press the Touch Sensor. The star is highlighted.
- **Trackball Mode:** Highlight the file you want to star and drag your finger from left to right across the Touch Sensor. The star is highlighted.

Unstarring a File

- 1 Select the file you want to unstar.
- 2 Unstar the selected file.
 - **Mouse Mode:** Position the mouse pointer over the star located in the same row as the filename and press the Touch Sensor. The star is no longer highlighted.
 - **Trackball Mode:** Highlight the file you want to unstar and drag your finger from right to left across the Touch Sensor. The star is no longer highlighted.

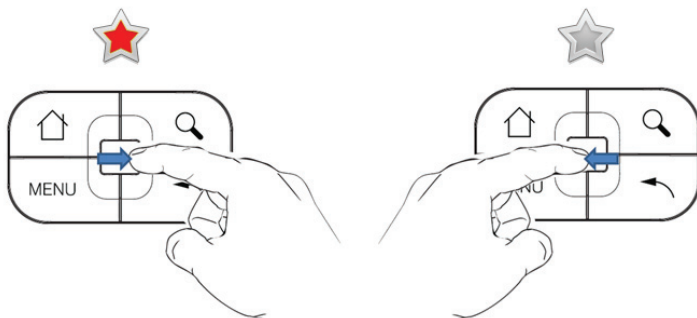

Opening Files

After you have located the file you want to open, open the file:

Mouse Mode: Position the mouse pointer over the file you want to open and press the Touch Sensor. The file opens.

Trackball Mode: Highlight the file you want open and press the Touch Sensor. The file opens.

Documents To Go Supported File Formats

Documents To Go supports the following files formats.

- Word 97, 2000, X, XP, 2003, 2007, 2010 for Windows
- Word 98, 2001, 2004, 2008 for Macintosh
- Excel 97, 2000, X, XP, 2003, 2007, 2010 for Windows
- Excel 98, 2001, 2004, 2008 for Macintosh
- PowerPoint 97, 2000, X, XP, 2003, 2007, 2010 for Windows
- PowerPoint 98, 2001, 2004, 2008 for Macintosh
- Apple iWork '08 & '09 (iWork '05, '06 are not supported)
- PDF
- Text (.txt)
- Rich Text Format (.rtf)
- HTML (.html, .htm)
- Images (.bmp, .jpeg, .gif, .tif, .svg, .png)

Important Note: If a file in the file list is not supported by Documents To Go, the application associated with the file will open instead. For example, if you select a video from the file list, the video player will open and start playing the video.

Documents To Go does not officially support documents created or edited with Open Office, Star Office, or other non-Office 'compatibility' formats. While these files may open in Documents To Go, it is not recommended to use these files with Documents To Go.

File formats may be distinguished based on the file extension and icon for that file in Documents To Go:

Example: Word 2007-2008 (top) vs. Word 97-2004 (bottom)

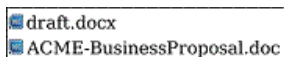

Documents to Go Settings

- About shows the version of Documents To Go.
- The Register, Check for Updates and Give Us Feedback selections are not supported in the standard version.
- Only Remember Last Location is supported under Advanced Options. Remember Last Location brings you back to the last file location you were in when you last closed Documents To Go.

Word To Go™

Word To Go opens when you open a .doc or .docx file. While the file is opening, a progress bar appears in the upper right-hand corner of the screen and some functions, such as creating a new file, are disabled. Some files may take longer than others due to their content and length.

Viewing and Navigating in a Document

While viewing a document, you can zoom and scroll up or down the page, go to the top or bottom of the page, or go to a bookmark.

Changing the Page Zoom Level

- 1 Open the Zoom dialog by pressing the Menu button and selecting View.
- 2 Choose the zoom level. 100% is the default.

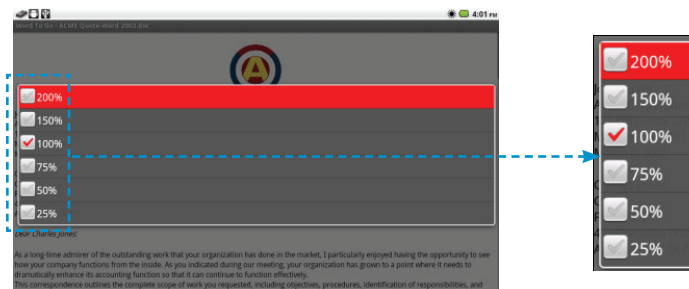

Changing the Zoom Level for an Individual Graphic

- 1 Place the cursor before the graphic.
- 2 Choose Selection Mode.

3 Select the graphic:

- **Mouse Mode:** Place the mouse pointer over the graphic.
- **Trackball Mode:** Place the cursor beside the graphic and move the trackball from left to right to highlight the graphic.

4 Press Touch Sensor to bring the graphic into the zoom state screen.

- **Mouse Mode:** Click on the graphic and a plus and minus button appears at the bottom of the screen. (The buttons disappear if you do not use them within a few seconds.) Use the buttons to increase or decrease the zoom level.
- **Trackball Mode:** To increase or decrease the graphic size, you need to use Mouse Mode. To change to Mouse Mode, hold down the Search button and follow the instructions above.

5 Press the Back button to return to the document.

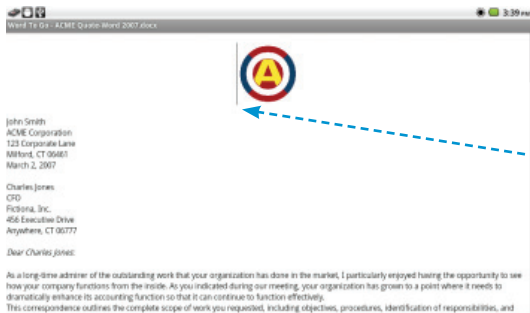

Move the cursor next to the graphic you want to zoom.

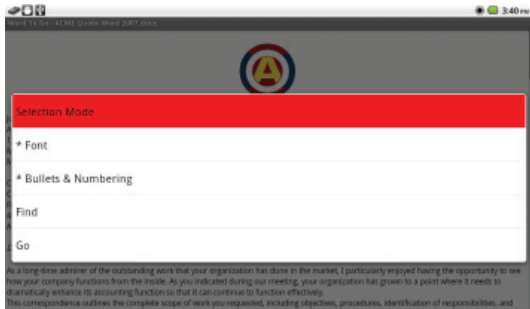

Choose Selection Mode.

Highlight and click on the graphic. The graphic appears in the zoom state screen.

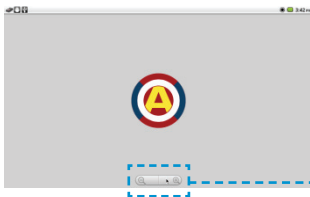
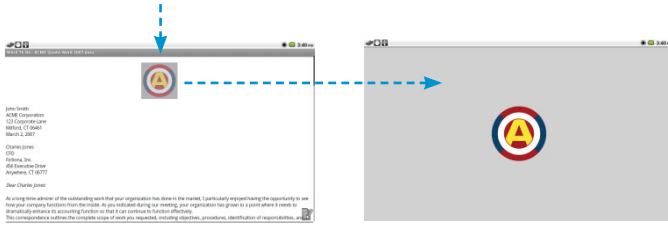

For Mouse Mode only, use the plus and minus signs to increase or decrease the size of the graphic.





Scrolling Up or Down a Page

- **Mouse Mode:** Press the Touch Sensor down and drag your finger across the button to scroll. Move the button quickly. Tap the button on the screen to stop the scrolling.
- **Trackball Mode:** Move your finger across the button to scroll. It moves the cursor up or down while moving the page up or down.

Go to the Top, Bottom of Document or Go to Bookmark

- 1 Open the Go dialog by pressing the Menu button.
- 2 Select View and then Go.
- 3 Choose Go to Top, Go to Bottom, or Go To Bookmark.

Icons You May See in a Document

Icon	What it means
	Headers, footers, comments.
	Table of Contents
	Object not supported

Basic Editing

You can select text or objects, such as graphics, and cut or copy the selections. You can then paste the selection into another section of the document or another document.

Selecting Text or Objects for Copy, Cut or Paste

- 1 Place the cursor where you want to begin or end the selection.
- 2 Enable Selection mode or Select All by pressing Menu.
- 3 Select Edit.
- 4 Choose Select. The Selection Mode will appear in the lower right-hand corner.



← Selection Mode icon

- 5 Move the cursor up or down to select the text and objects.
- 6 Press the Touch Sensor. A context menu will appear with the following options for the selected text or object:
 - Cancel Selection – Exit Selection Mode and deselect.
 - Copy – Copy the selected text and objects and exit Selection Mode
 - Cut – Copy and then delete the selected text and objects and exit Selection Mode
 - Paste – Replace selected text and objects with previously copied text and exit Selection Mode

- *Font – Not supported in the standard version.
- *Bullet & Numbering – Not supported in the standard version.
- *Word Count – Not supported in the standard version.

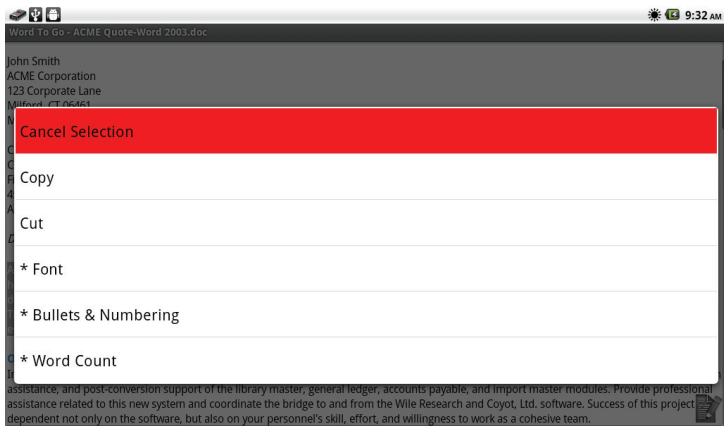

Finding Text in a Document

You can search your document for a word or sentence using the Find function.

- 1 Press Menu.
- 2 Select View.
- 3 Select Find.
- 4 Type the text you want to find using the onscreen keyboard. Open the onscreen keyboard by pressing the Touch Sensor.
- 5 Press the Enter button on the onscreen keyboard.
- 6 Select Find again to find the next occurrence in the document.

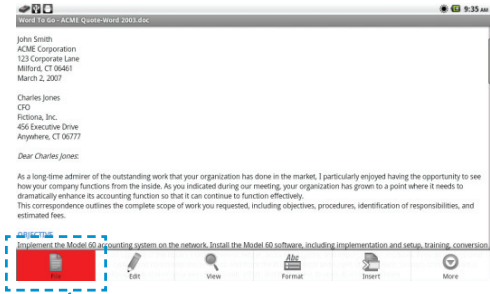

To find text in a document, press **Menu** and then select **View**.

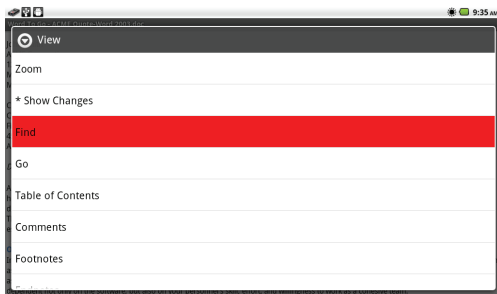
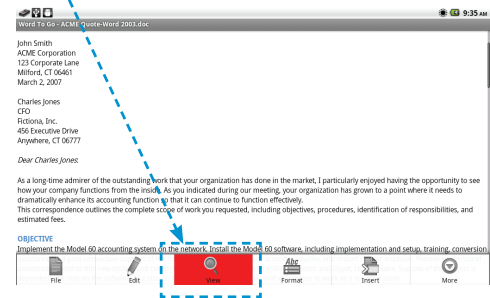

Select **Find** and type in text you want to find using the onscreen keyboard.

Find Options

- **Case Sensitive** - Finds matches to both text and character case (upper or lower).
- **Whole Words Only** – Finds complete words only. For example, if you type “boat” and do not select Whole Words Only, Find What will find “boat”, “boathouse” and “sailboat”.

Note: Replace and Replace All is not a supported feature in the standard version.

Viewing and Editing Tables

Tables will appear as they do in Microsoft Word excluding some table formatting, such as border and cell color. You can select the text in the table.

Selecting a Cell

Mouse Mode: Position the mouse pointer inside the cell. Press the Touch Sensor and the cursor will appear in the cell.

Trackball Mode: Move your finger across the Touch Sensor in the direction of the cell and the selected cell is highlighted.

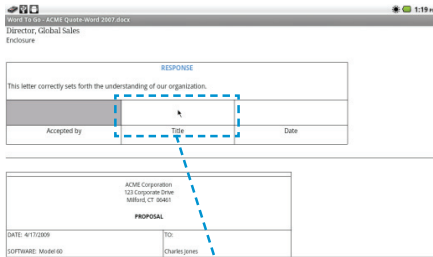

- Using **Mouse Mode**, move the cursor into the table cell you want to edit.
- Press the Touch Sensor. The cursor appears in the cell.

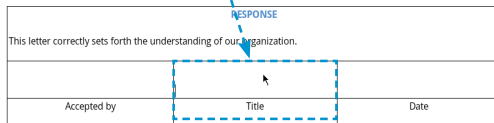

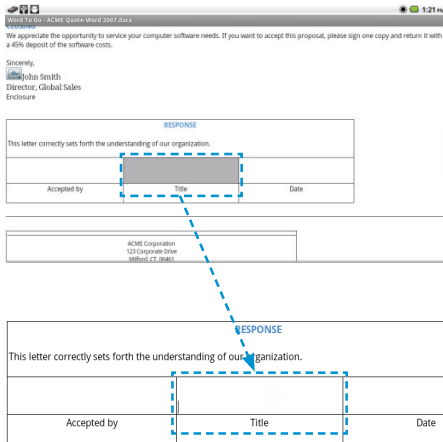

- Using **Trackball Mode**, use the Touch Sensor to select a cell. The cell is highlighted.
- The cursor appears in the cell.

Editing a Table

Mouse Mode:

- 1 Press and hold the Menu button until the onscreen keyboard appears.
- 2 Make your changes using the onscreen keyboard.
- 3 When you are finished making changes, press Done.

Trackball Mode:

- 1 Press the Touch Sensor to enter the cell.
- 2 Press again to open the onscreen keyboard.
- 3 When you are finished making changes, press Done.

Exiting a Table Edit

Mouse Mode: Position the pointer outside the cell. Press the Touch Sensor to exit.

Trackball Mode: Press the Back button until the cell is highlighted again.

Selecting Hyperlinks

The 3M MP220 projector does not have a Wi-Fi or mobile network connection, so hyperlinks that open web pages will not work.

Viewing and Editing Comments

You can view and edit the comments in a document. Each comment is preceded by the author's initials and a number. The author's initials are the highlighted characters within brackets.

Opening the Comments Pane

- 1 Press the Menu button.
- 2 Select View and then Comments. The Comments pane will open.
- 3 Move to the location in the document where the comment appears
 - **Mouse Mode:** Position the mouse pointer over the comment's author. Press the Touch Sensor and you will be brought to that section in the document.
 - **Trackball Mode:** Move the cursor to one side of the comment's author. Move your finger across the Touch Sensor in the direction of the author. The author is highlighted. Press the Touch Sensor and you will move to the section of the document.

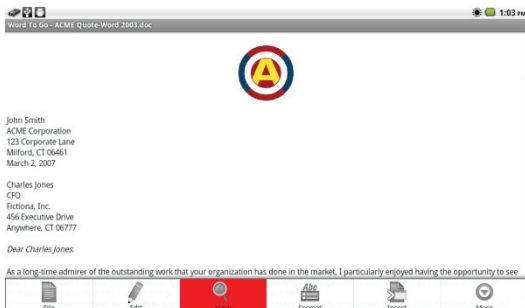

To add comments, select **View** and then select **Comments** from the menu.

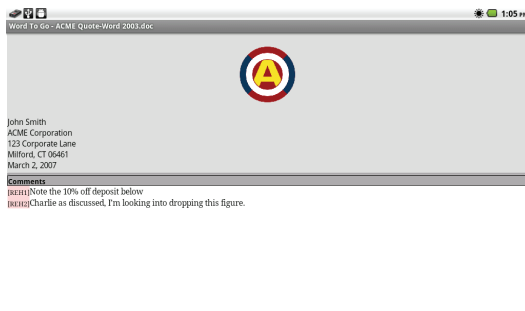

The Comments pane opens below the document.

Press the **Menu** button to use the onscreen keyboard.

Editing the Comments

- 1 Place the cursor in the location of the comment you wish to edit.
- 2 Press and hold the Menu button.
- 3 Use the onscreen keyboard to edit the text.

Closing the Comments Pane

Press the Back Button.

Word to Go™ Preferences

Only one preference is supported in the standard version. For this version, preferences provide a way to fit the table to the screen width.

- Display table in compressed view – When checked, Word to Go fits the table to the screen width.

Notes:

- *The standard version of Word To Go does not handle cropped pictures. In Microsoft Word, you need to delete the cropped area when compressing the picture.*
- *Word To Go does not display tracked changes in the standard version.*
- *Word To Go Basic does not track changes made while editing in the standard version.*

Sheet To Go®

Sheet To Go opens an .xls or .xlsx file. While the file opens, a progress bar appears in the upper right-hand corner of the screen and some functions such as creating a new file are disabled. Some files may take longer than others due to their content and length.

Files Supported

Sheet To Go opens Excel 1997–2003 (.xls) and Excel 2007-2010 (.xlsx) workbooks.

- Some features available in Microsoft Excel are not available in Sheet To Go.
- Some unsupported features are embedded objects and data validation controls.
- Unsupported features are not affected when a workbook is edited or saved.

Viewing and Navigating a Spreadsheet

You can view and navigate within a spreadsheet and workbook files, edit cell contents, and edit spreadsheet columns and rows.

When you select an .xls or .xlsx file, Sheet To Go opens and displays the spreadsheet.

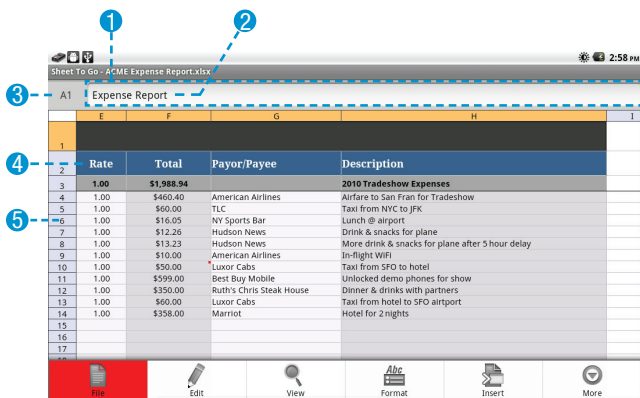

1 Name Box

2 Formula

- 3 Selected Cell
- 4 Column Name
- 5 Row Number

Notes:

- 1 *Picture, SmartArt, and charts are not displayed.*
- 2 *Chart sheets will not open. The word (CHART) appears beside the worksheet name identifying that worksheet as a chart sheet.*
- 3 *When number data is greater than the column width, the cell displays "####".*

Opening and Saving Workbooks

You can perform many file functions within Sheet To Go. Use the File dialog to open and save your files.

Opening the File Dialog

- 1 While you have another file open, press the Menu button.
- 2 Select File and the File dialog will appear.

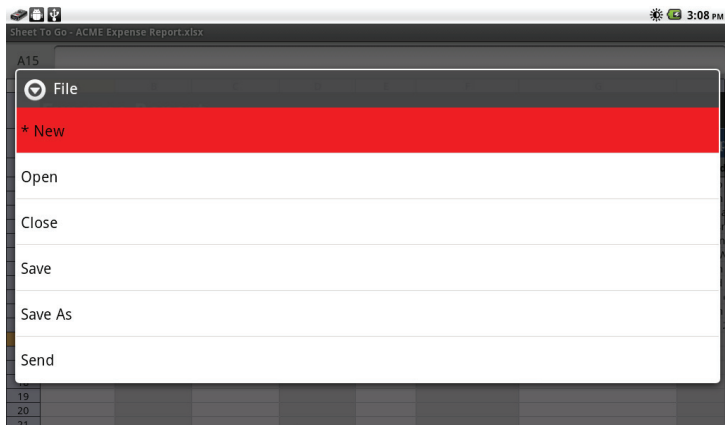

- 1 *New – Not supported in the standard version.

- 2 Open – Opens local files on the internal memory or SD Card.
- 3 Close – Closes the current file and returns you to Documents To Go.
- 4 Save – Saves your changes to the file.
- 5 Save As – Saves a copy of a file with changes under another filename and location.
- 6 Send – Not supported in the standard version.

Viewing and Navigating Within a Spreadsheet and Workbook

The currently selected cell is noted by a black border around the cell and the cell contents or formula will appear in the formula bar.

Selecting a Cell

Mouse Mode: Move the mouse pointer over the cell. Press the Touch Sensor.

Trackball Mode: Move your finger across the Touch Sensor in the direction of a cell and the selector will move.

Selecting More Than One Cell or Range of Cells

- 1 Select a cell.
- 2 Press and hold the Touch Sensor. The context menu will appear.
- 3 Select "Selection Mode".
- 4 Select the furthest-diagonal cell from the initially selected cell and the selected area will be grayed out.

Sheet To Go - ACME Expense Report.xlsx

B16

1	Expense Report							
2	Date	Travel	Meals&Ent	Other	Rate	Total	Payor/Payee	Descrip
3	May 19-20	\$988.40	\$391.54	\$609.00	1.00	\$1,988.94	2010 Trad	
4	9-May-10	\$460.40	\$0.00	\$0.00	1.00	\$460.40	American Airlines	Airfare to
5	18-May-10	\$60.00	\$0.00	\$0.00	1.00	\$60.00	TLC	Taxi from
6	18-May-10	\$0.00	\$16.05	\$0.00	1.00	\$16.05	NY Sports Bar	Lunch @
7	18-May-10	\$0.00	\$12.26	\$0.00	1.00	\$12.26	Hudson News	Drink & s
8	18-May-10	\$0.00	\$13.23	\$0.00	1.00	\$13.23	Hudson News	More drin
9	18-May-10	\$0.00	\$0.00	\$10.00	1.00	\$10.00	American Airlines	In-flight v
10	18-May-10	\$50.00	\$0.00	\$0.00	1.00	\$50.00	Luxor Cabs	Taxi from
11	19-May-10	\$0.00	\$0.00	\$399.00	1.00	\$399.00	Best Buy Mobile	Unlocked
12	19-May-10	\$0.00	\$350.00	\$0.00	1.00	\$350.00	Ruth's Chris Steak House	Dinner &
13	20-May-10	\$60.00	\$0.00	\$0.00	1.00	\$60.00	Luxor Cabs	Taxi from
14	20-May-10	\$358.00	\$0.00	\$0.00	1.00	\$358.00	Marmot	Hotel for
15								
16								
17								
18								
19								
20								
21								

Select the
furthest-diagonal

Sheet To Go - ACME Expense Report.xlsx

B16

1	Expense Report							
2	Date	Travel	Meals&Ent	Other	Rate	Total	Payor/Payee	Descrip
3	May 19-20	\$988.40	\$391.54	\$609.00	1.00	\$1,988.94	2010 Trad	
4	9-May-10	\$460.40	\$0.00	\$0.00	1.00	\$460.40	American Airlines	Airfare to
5	18-May-10	\$60.00	\$0.00	\$0.00	1.00	\$60.00	TLC	Taxi from
6	18-May-10	\$0.00	\$16.05	\$0.00	1.00	\$16.05	NY Sports Bar	Lunch @
7	18-May-10	\$0.00	\$12.26	\$0.00	1.00	\$12.26	Hudson News	Drink & s
8	18-May-10	\$0.00	\$13.23	\$0.00	1.00	\$13.23	Hudson News	More drin
9	18-May-10	\$0.00	\$0.00	\$10.00	1.00	\$10.00	American Airlines	In-flight v
10	18-May-10	\$50.00	\$0.00	\$0.00	1.00	\$50.00	Luxor Cabs	Taxi from
11	19-May-10	\$0.00	\$0.00	\$399.00	1.00	\$399.00	Best Buy Mobile	Unlocked
12	19-May-10	\$0.00	\$350.00	\$0.00	1.00	\$350.00	Ruth's Chris Steak House	Dinner &
13	20-May-10	\$60.00	\$0.00	\$0.00	1.00	\$60.00	Luxor Cabs	Taxi from
14	20-May-10	\$358.00	\$0.00	\$0.00	1.00	\$358.00	Marmot	Hotel for
15								
16								
17								
18								
19								
20								
21								

Selected area will
be grayed out.

Switching Between Spreadsheets in a Workbook

- 1 Press the Menu button.
- 2 Select View.
- 3 Select Worksheets and a list of worksheets will appear.
- 4 Select a worksheet. The Worksheet will open.

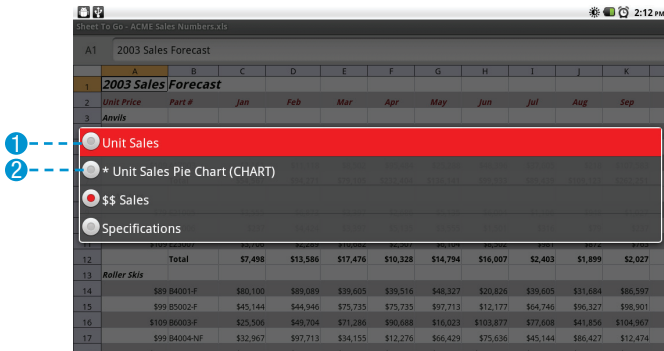

- 1 Selected Worksheet
- 2 Chart worksheet – Not supported in the standard version.

Going to a Cell, Home or End Position of a Spreadsheet

- 1 Press the Menu button.
- 2 Select Go.
- 3 Select To Cell, Home, or End.
 - To Cell – Specify a cell you want to move using an alphanumerical cell reference.
 - Home – Moves the selector to the first row in a column. Select it again and it moves the selector to the first column in the row.
 - End – Moves the selector to the last populated cell in the worksheet.

Using Zoom

While viewing a worksheet, you can zoom and scroll up or down the page.

Zoom the Page

- 1 Open the Zoom dialog by pressing the Menu button.
- 2 Select View.
- 3 Choose the zoom level. 100% is the default.

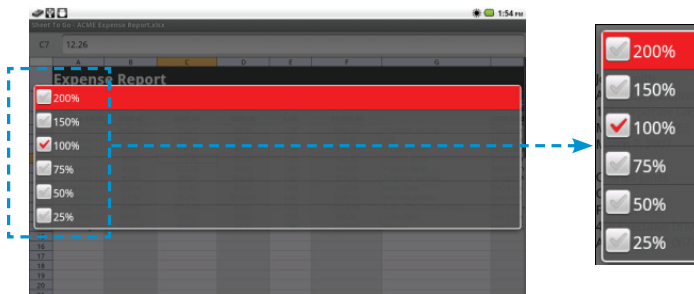

Scrolling Up or Down the Spreadsheet

Mouse Mode: In one motion, press and swipe your finger across the Touch Sensor in the direction you want to scroll the page. Tap the Touch Sensor to stop the page from scrolling further.

Trackball Mode: Move your finger across the Touch Sensor. Move the cursor up or down on the page.

Using Freeze Panes

- 1 Select the cell where you want the freeze pane to appear above and to the left of.
- 2 Press the Menu Button.
- 3 Select View.
- 4 Select Freeze Panes.

Modifying a Spreadsheet

Selecting Rows or Columns

- 1 Move the selector to a cell in the row or column you want to select.
- 2 Press the Menu button.
- 3 Select More.
- 4 Select Row or Column and a context menu will appear.
- 5 Select "Select Row" or "Select Column" and the row or column will be highlighted gray.

Expense Report								
	Date	Travel	Meals&Ent	Other	Rate	Total	Payor/Payee	Description
3	May 19-20	\$888.40	\$391.54	\$609.00	1.00	\$1,988.94		2010 Travel
4	9-May-10	\$460.40	\$0.00	\$0.00	1.00	\$460.40	American Airlines	Airfare to
5	18-May-10	\$60.00	\$0.00	\$0.00	1.00	\$60.00	TLC	Taxi from
6	18-May-10	\$0.00	\$16.05	\$0.00	1.00	\$16.05	NY Sports Bar	Lunch @
7	18-May-10	\$0.00	\$12.26	\$0.00	1.00	\$12.26	Hudson News	Drink & s
8	18-May-10	\$0.00	\$13.23	\$0.00	1.00	\$13.23	Hudson News	More drin
9	18-May-10	\$0.00	\$0.00	\$10.00	1.00	\$10.00	American Airlines	In-flight
10	18-May-10	\$50.00	\$0.00	\$0.00	1.00	\$50.00	Luxor Cabs	Taxi from
11	19-May-10	\$0.00	\$0.00	\$599.00	1.00	\$599.00	Best Buy Mobile	Unlocked
12	19-May-10	\$0.00	\$350.00	\$0.00	1.00	\$350.00	Ruth's Chris Steak house	Dinner &
13	20-May-10	\$268.00	\$0.00	\$0.00	1.00	\$268.00	Marriott	Hotel for
14	20-May-10	\$268.00	\$0.00	\$0.00	1.00	\$268.00	Marriott	Hotel for
15								
16								
17								
18								
19								
20								
21								

Select the row and then press the **Menu** button and select **More**.

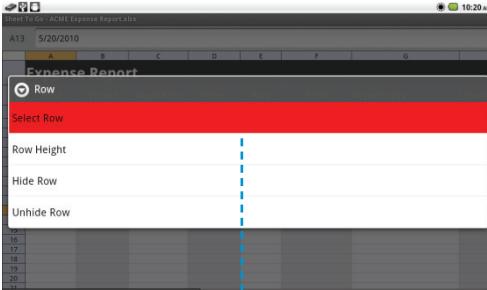

Choose **Select Row** from the menu and the row is highlighted in the spreadsheet.

1	Expense Report							
2	Date	Travel	Meals&Ent	Other	Rate	Total	Payer/Payee	Descrpt
3	May 19-20	\$988.40	\$391.34	\$409.00	1.00	\$1,388.74		2010 Trip
4	9-May-10	\$460.40	\$0.00	\$0.00	1.00	\$460.40	American Airlines	Airfare for
5	18-May-10	\$60.00	\$0.00	\$0.00	1.00	\$60.00	TLC	Taxi from
6	18-May-10	\$0.00	\$16.05	\$0.00	1.00	\$16.05	NY Sports Bar	Lunch @
7	18-May-10	\$0.00	\$12.26	\$0.00	1.00	\$12.26	Hudson News	Drink &
8	18-May-10	\$0.00	\$13.23	\$0.00	1.00	\$13.23	Hudson News	More drin
9	18-May-10	\$0.00	\$0.00	\$10.00	1.00	\$10.00	American Airlines	In-flight
10	18-May-10	\$50.00	\$0.00	\$0.00	1.00	\$50.00	Luxor Cabs	Taxi from
11	19-May-10	\$0.00	\$0.00	\$599.00	1.00	\$599.00	Best Buy Mobile	Unlocked
12	19-May-10	\$0.00	\$350.00	\$0.00	1.00	\$350.00	Beth's Church Steak House	Dinner &
13	20-May-10	\$60.00	\$0.00	\$0.00	1.00	\$60.00	Luxor Cabs	Taxi from
14	20-May-10	\$358.00	\$0.00	\$0.00	1.00	\$358.00	Marriott	Hotel for
15								
16								
17								
18								
19								
20								
21								

Hiding Rows or Columns

- 1 Move the selector to a cell in the row or column you want to hide.
- 2 Press the Menu Button.
- 3 Select More.
- 4 Select Row or Column and a context menu will appear.
- 5 Select Hide Row or Hide Column.

Unhiding Rows or Columns

- 1 Move the selector to a cell next to the hide row or column and press and hold the Touch Sensor.
- 2 Choose Selection Mode and select a cell on the opposite side of the hidden row or column.
- 3 Select More.

- 4 Select Row or Column and a context menu will appear.
- 5 Select Unhide Row or Unhide Column.

Changing Height of Rows

- 1 Move the selector to a cell in the row you want to change the height of.
- 2 Press the Menu Button.
- 3 Select More.
- 4 Select Row Height and a gray bar will appear below the row.
- 5 Move the gray bar up or down to mark the new cell height.
 - **Mouse Mode:** Move the pointer over the gray bar. While pressing and holding the Touch Sensor, move your finger up or down across the sensor. Release the Touch Sensor once you have the gray bar positioned.
 - **Trackball Mode:** Move your finger up or down across the Touch Sensor and move the gray bar.
- 6 Accept the new row height by pressing the Touch Sensor.

1	Expense Report							
2	Date	Travel	Meals&Ent	Other	Rate	Total	Payor/Payee	Description
3	May 19-20	\$988.40	\$391.34	\$409.00	1.00	\$1,388.74		2010 Travel
4	9-May-10	\$460.40	\$0.00	\$0.00	1.00	\$460.40	American Airlines	Airfare to
5	18-May-10	\$60.00	\$0.00	\$0.00	1.00	\$60.00	TLC	Taxi from
6	18-May-10	\$0.00	\$16.00	\$0.00	1.00	\$16.00	NY Sports Bar	Lunch @
7	18-May-10	\$0.00	\$12.26	\$0.00	1.00	\$12.26	Hudson News	Drink & tip
8	18-May-10	\$0.00	\$13.23	\$0.00	1.00	\$13.23	Hudson News	More drive
9	18-May-10	\$0.00	\$0.00	\$10.00	1.00	\$10.00	American Airlines	In-flight
10	18-May-10	\$50.00	\$0.00	\$0.00	1.00	\$50.00	Luxor Cabs	Taxi from
11	19-May-10	\$0.00	\$0.00	\$599.00	1.00	\$599.00	Best Buy Mobile	Unlocked
12	19-May-10	\$0.00	\$350.00	\$0.00	1.00	\$350.00	Ruth's Chris Steak House	Dinner &
13	20-May-10	\$0.00	\$0.00	\$0.00	1.00	\$0.00	Luxor Cabs	Taxi from
14	20-May-10	\$358.00	\$0.00	\$0.00	1.00	\$358.00	Marnot	Hotel for
15								
16								
17								
18								
19								
20								
21								

Select a cell in the row for which you want to change the height.

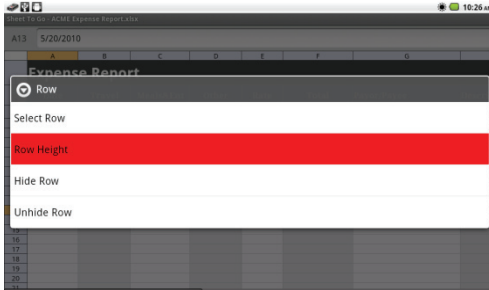

After you press the **Menu** button and select **More**, select **Row Height** and a gray bar appears over the selected row.

Use the gray bar as the starting point for increasing the height of a row.

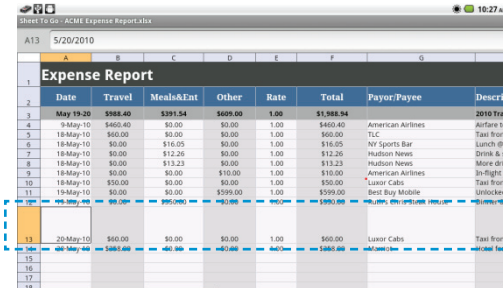
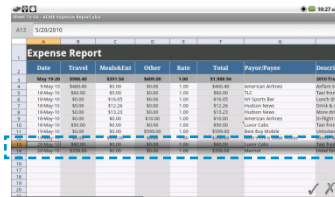

Accept the new height by pressing the Touch Sensor.

Changing Column Widths

- 1 Move the selector to a cell in the column you want to change the width of.
- 2 Press the Menu Button.
- 3 Select More.
- 4 Select Column Width and a gray bar will appear below the row.
- 5 Move the gray bar right or left to mark the new column width.

- **Mouse Mode:** Move the pointer over the gray bar. While pressing and holding the Touch Sensor, move your finger right or left across the sensor. Release the Touch Sensor once you have the gray bar positioned.
- **Trackball Mode:** Move your finger right or left across the Touch Sensor and move the gray bar.

6 Accept the new row height by pressing the Touch Sensor.

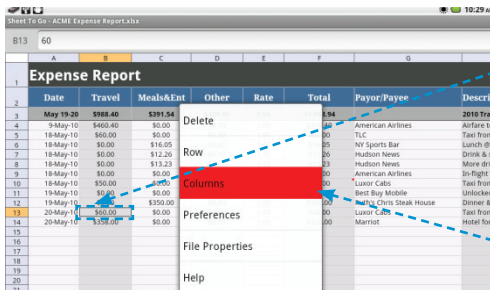

Select a cell in the column for which you want to change the width.

After you press the **Menu** button and select **More**, select **Columns**.

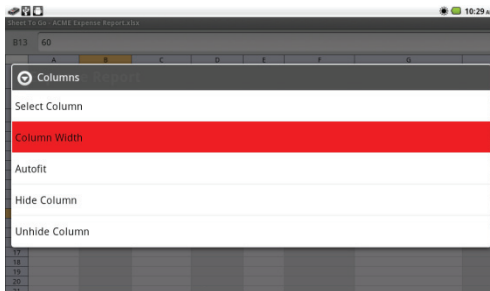

Select **Column Width** and a gray bar appears over the selected column.

Use the gray bar as the starting point for increasing the width of the column.

1	Expense Report						
2	Date	Travel	Meals&Ent	Other	Rate	Total	Payor/Payee
3	May 19	\$588.40	\$391.54	\$609.00	1.00	\$1,588.94	
4	19-May	\$460.40	\$0.00	\$0.00	1.00	\$460.40	American Airlines
5	18-May	\$60.00	\$0.00	\$0.00	1.00	\$60.00	TLC
6	18-May	\$0.00	\$0.00	\$0.00	1.00	\$0.00	Marriott
7	18-May	\$12.26	\$0.00	\$0.00	1.00	\$12.26	Marriott
8	18-May	\$0.00	\$13.23	\$0.00	1.00	\$13.23	Hudson News
9	18-May	\$0.00	\$0.00	\$10.00	1.00	\$10.00	American Airlines
10	18-May	\$50.00	\$0.00	\$0.00	1.00	\$50.00	Luxor Cabs
11	19-May	\$0.00	\$0.00	\$595.00	1.00	\$595.00	Best Buy Mobile
12	19-May	\$0.00	\$350.00	\$0.00	1.00	\$350.00	Ruth's Chris Steak House
13	20-May	\$60.00	\$0.00	\$0.00	1.00	\$60.00	Luxor Cabs
14	20-May	\$358.00	\$0.00	\$0.00	1.00	\$358.00	Marriott

Accept the new width by pressing the Touch Sensor.

Rows and Columns

Sheet To Go inserts new rows above the selected cell and new columns to the left of the selected cell.

Inserting Rows and Columns

- 1 Move the selector to a cell where you want to insert the new row or column.
- 2 Press the Menu Button.
- 3 Select Insert.
- 4 Select Row or Column and a dialog will appear.
- 5 Select OK and the new row or column is inserted.

Deleting Rows and Columns

- 1 Move the selector to a cell that is the row or column you want to delete.
- 2 Press the Menu Button.
- 3 Select More.

- 4 Select Delete and a context menu will appear.
- 5 Select Row or Column and a dialog will appear.
- 6 Select OK and the row or column is deleted.

Modifying the Spreadsheet Name

- 1 Press the Menu Button.
- 2 Select Format.
- 3 Select Sheet and the Format Sheet dialog will appear.
- 4 Press the Touch Sensor and the onscreen keyboard will appear.
- 5 Use the onscreen keyboard to modify the worksheet name and press the Back button.
- 6 Select OK.

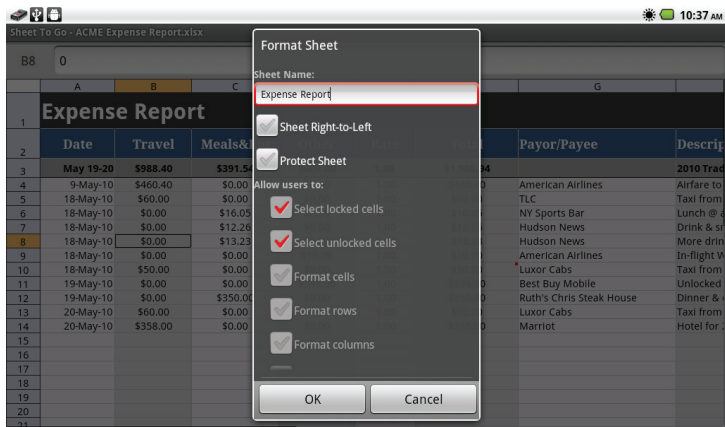

Finding Text or Data in a Spreadsheet or Workbook

- 1 Press the Menu Button.
- 2 Select View.
- 3 Select Find and the Find dialog appears.
- 4 Press the Touch Sensor and the onscreen keyboard will appear.

- Use the onscreen keyboard to type in the text, number or cell reference you want to find. Press the Back button to exit the onscreen keyboard.

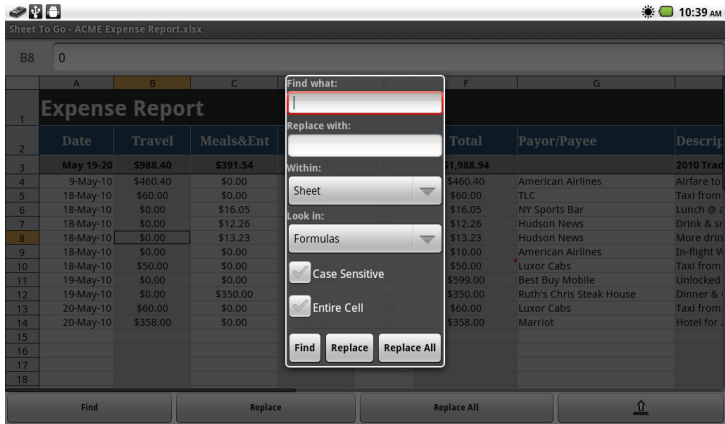

- Find What – Enter the text, number or cell reference you wish to find.
- Within – Select Sheet or Workbook to direct the search.
- Look in – Search formulas, values or comments.
 - Formulas - Search reports matches within the cell content including individual numbers and letters in formulas.
 - Values - Search reports matches from the cell values, such as the result of a formula.
 - Comments - Search reports matches found in cell comments.

	A	B	C	D	E	F	G
1	Expense Report						
2	Date	Travel	Meals&Ent	Other	Rate	Total	Payor/Payee
3	May 19-20	\$988.40	\$391.54	\$609.00	1.00	\$1,988.94	2010 Trad
4	9-May-10	\$460.40	\$0.00	\$0.00	1.00	\$460.40	American Airlines
5	18-May-10	\$60.00	\$0.00	\$0.00	1.00	\$60.00	TLC
6	18-May-10	\$0.00	\$16.05	\$0.00	1.00	\$16.05	NY Sports Bar
7	18-May-10	\$0.00	\$12.26	\$0.00	1.00	\$12.26	Hudson News
8	18-May-10	\$0.00	\$13.23	\$0.00	1.00	\$13.23	Hudson News
9	18-May-10	\$0.00	\$0.00	\$10.00	1.00	\$10.00	American Airlines
10	18-May-10	\$50.00	\$0.00	\$0.00	1.00	\$50.00	Luxor Cabs
11	19-May-10	\$0.00	\$0.00	\$599.00	1.00	\$599.00	Best Buy Mobile
12	19-May-10	\$0.00	\$350.00	\$0.00	1.00	\$350.00	Ruth's Chris Steak House
13	20-May-10	\$60.00	\$0.00	\$0.00	1.00	\$60.00	Luxor Cabs
14	20-May-10	\$358.00	\$0.00	\$0.00	1.00	\$358.00	Marriot
15							
16							
17							
18							

The Find toolbar appears at the bottom of the dialog.

- 1 Find – Press to find the next occurrence.
- 2 Replace – Not supported in the standard version.
- 3 Replace All – Not supported in the standard version.
- 4 Open Find dialog – Opens the Find dialog.

Editing Cells

Mouse Mode

Modify using the formula bar:

- 1 Select the cell by placing the mouse pointer over the cell and pressing the Touch Sensor.
- 2 Place the mouse pointer inside the formula bar and press the Touch Sensor.
- 3 Use the onscreen keyboard to modify the content of the cell.

Modify using the context menu:

- 1 Place the mouse pointer over the cell.
- 2 Press and hold the Touch Sensor. The context menu will appear.
- 3 Select Edit Cell.

- 4 Use the onscreen keyboard to modify the content of the cell.

Modify using the Menu button:

- 1 Select the cell by placing the mouse pointer over the cell and pressing the Touch Sensor.
- 2 Press the Menu button.
- 3 Select Edit and then Edit Cell.
- 4 Use the onscreen keyboard to modify the content of the cell.
- 5 Press Back to exit the onscreen keyboard.
- 6 Press Back again to exit the formula bar.

Trackball Mode**Modify using the formula bar:**

- 1 Select the cell by moving your finger across the Touch Sensor in the direction of the cell and press the Touch Sensor.
- 2 Use the onscreen keyboard to modify the content of cell.

Modify using the context menu:

- 1 Select the cell by moving your finger across the Touch Sensor in the direction of the cell and press and hold the Touch Sensor. The context menu will appear.
- 2 Select Edit Cell.
- 3 Use the onscreen keyboard to modify the content of the cell.

Modify using the Menu button:

- 1 Select the cell by moving your finger across the Touch Sensor in the direction of the cell.
- 2 Press the Menu button.
- 3 Select Edit and then Edit Cell.
- 4 Use the onscreen keyboard to modify the content of the cell.
- 5 Press Back to exit the onscreen keyboard.
- 6 Press Back again to exit the formula bar.

Viewing Cell Contents

Mouse Mode

- 1 Select the cell by placing the mouse pointer over the cell and pressing the Touch Sensor.
- 2 Press the Menu button.
- 3 Select View.
- 4 Select Cell Contents. The Cell Contents dialog will appear.
- 5 Press Back or select OK to exit the dialog.

Trackball Mode

- 1 Select the cell by moving your finger across the Touch Sensor in the direction of cell.
- 2 Press the Menu button.
- 3 Select View.
- 4 Select Cell Contents. The Cell Contents dialog will appear.
- 5 Press Back or select OK to exit the dialog.

Sheet To Go - ACME Expense Report.xlsx 10:44 AM

B14 =179*2

	A	B	C	D	E	F	G
1	Expense Report						
2	Date	Travel	Meals&Ent	Other	Rate	Total	Payor/Payee
3	May 19-20	\$988.40	\$391.50				2010 Trad
4	9-May-10	\$460.40	\$0.00				American Airlines
5	18-May-10	\$60.00	\$0.00				TLC
6	18-May-10	\$0.00	\$12.00				NY Sports Bar
7	18-May-10	\$0.00	\$12.25				Hudson News
8	18-May-10	\$0.00	\$13.25				Hudson News
9	18-May-10	\$0.00	\$0.00				American Airlines
10	18-May-10	\$50.00	\$0.00				Luxor Cabs
11	19-May-10	\$0.00	\$0.00				Best Buy Mobile
12	19-May-10	\$0.00	\$350.00				Ruth's Chris Steak House
13	20-May-10	\$60.00	\$0.00	\$0.00	1.00	\$60.00	Luxor Cabs
14	20-May-10	\$358.00	\$0.00	\$0.00	1.00	\$358.00	Marriot
15							
16							
17							
18							
19							
20							
21							

Advanced Editing

Selecting a Cell or Multiple Cells

- 1 Enter Selection Mode in one of two ways:
 - **Press and hold the Touch Sensor:**
 - 1 Select the cell where you want to start your selection.
 - 2 Press and hold the Touch Sensor. A context menu will appear.
 - 3 Choose the Selection Mode option.
 - **Menu, View, Select:**
 - 1 Select the cell where you want to start your selection.
 - 2 Press Menu.
 - 3 Select View.
 - 4 Choose the Selection Mode option.
- 2 If you want to select multiple cells, select a cell that makes up the corner of your final selection.
- 3 Press and hold the Touch Sensor. The context menu appears.
- 4 Choose Selection Mode.
- 5 Move the selector to grow or shrink the selection area.
- 6 Press and hold the Touch Sensor for more options or press the Back button to exit the selection mode.

Selection Mode Option Menu

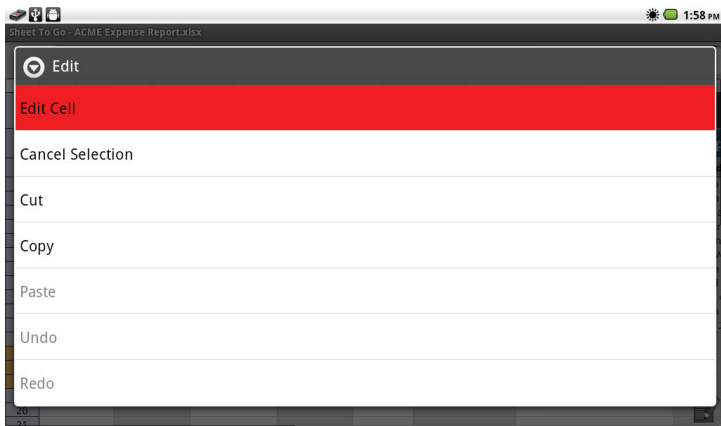

- 1 Edit Cell – Opens the onscreen keyboard and you can edit the contents of the first cell in your selection.
- 2 Cancel Selection – Exits Selection Mode.
- 3 Cut – Copies the selected cells and once you paste them into a new area of the spreadsheet, deletes them.
- 4 Copy - Copies the selected cells and allows you to paste them into a new area in the spreadsheet.
- 5 Paste – Lets you paste cells you cut or copied into another cell.

Copy, Paste, and Cut

- Copy and paste data from one area to another, or
- Cut and paste and move data from one area to another.

Copy and Paste

- 1 Select a cell or range.
- 2 Press and hold the Touch Sensor. An Options menu will appear.
- 3 Select Copy.
- 4 Move the Worksheet and Cell where you want to paste the data.

- 5 Press and hold the Touch Sensor. An Options menu will appear.
- 6 Select Paste.

Cut and Paste

- 1 Select a cell or range.
- 2 Press and hold the Touch Sensor. An Options menu will appear.
- 3 Select Cut.

Note: The selected cells are deleted after the paste function is executed.

- 4 Move the Worksheet and Cell where you want to paste the data.
- 5 Press and hold the Touch Sensor. An Options menu will appear.
- 6 Select Paste.

Formulas

Sheet To Go has many of the same functions you use in Microsoft Excel. This section will take you through the steps of entering the following formulas:

- Simple formulas,
- Formulas with cell references, and
- Formulas with formulas.

Simple formulas

- Formulas with single cell references, and
- Formulas with range of cell references.

Simple Formula: 1+1

- 1 Select a Cell.
- 2 Press the Touch Sensor and the onscreen keyboard opens.
- 3 Type =1+1.

Note: Access = by selecting the ?123 button and then the ALT button.

Formula with Cell Reference: A1+A2

- 1 Select a Cell where you want the results to appear. For this example, select cell A3.
- 2 Press the Touch Sensor and the onscreen keyboard opens.
- 3 Type = and press the Back button.
- 4 Press Menu and select Cell Reference.
- 5 Move the selector to the A1 cell and press Menu and then Enter.
- 6 Press Menu and select Operators.
- 7 Select + and press the Touch Sensor.
- 8 Press Menu and select Cell Reference.
- 9 Move the selector to the A2 cell and press Menu and then Enter.
- 10 Press Menu and then select Enter and the results will appear in the Cell.

Inserting Functions and AutoSum

- 1 Select the cell where you want the results of the function or autosum to appear.
- 2 Press Menu and select Insert.
- 3 Select Function or Autosum. The Insert Function screen appears.

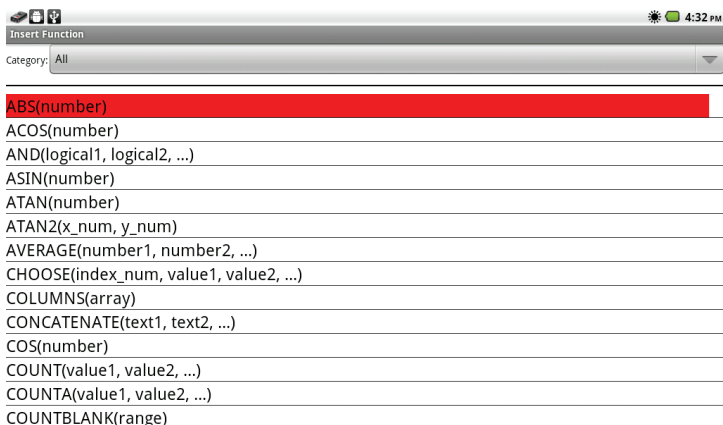

- 1 Category –Select category from the dropdown list to filter the list of functions shown.
- 2 Available Function –Select the function and it will be inserted into the cell.

Automatic Range Fill-in for Functions and AutoSum

If the cell is at the end of a row or bottom of a column, Sheet To Go will automatically fill in the range of cells containing numbers.

Selecting a Range for a Function or AutoSum

When selecting a range of cells in a function, you can only use Mouse Mode. If you see a mouse pointer on the screen, you are already in mouse mode.

You can easily switch from Trackball Mode to Mouse Mode by pressing and holding the Search button. When the Touch Sensor dialog appears, select OK.

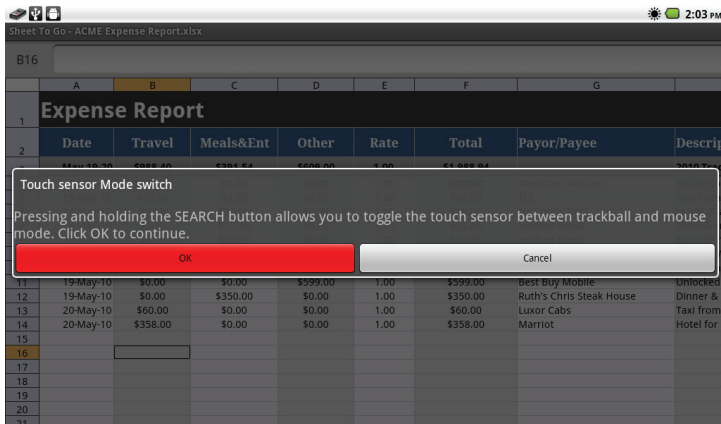

- 1 Select a cell that marks the corner of the range you want to select.
- 2 Press and hold the Touch Sensor. The context menu appears.
- 3 Select Selection Mode.
- 4 Move the selector to grow or shrink the selection area.
- 5 Press and hold the Touch Sensor for more options or press the Back button to exit the selection mode.

Locked or Read Only Files

Sheet To Go locks a file when the file contains objects or formulas that are not supported. When the file is locked, you cannot edit or save the file.

Sheet To Go Preferences

- 1 Open Sheet to Go Preferences by pressing Menu.
- 2 Select More.
- 3 Select Preferences.

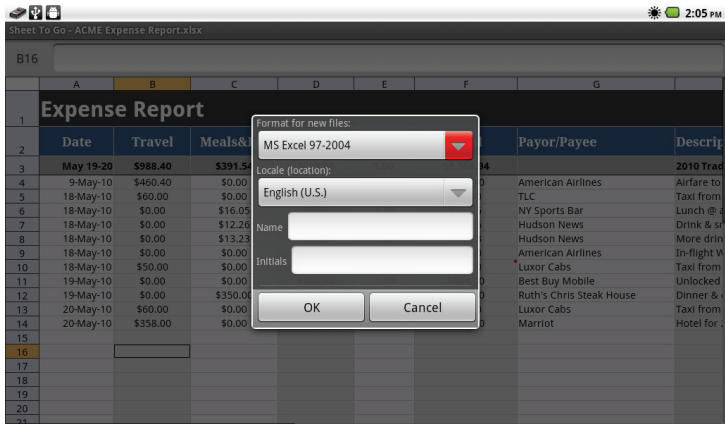

Only one preference is supported in the standard version. Preferences allow you to perform location formatting.

- 1 Locale (locations) – Defines how certain numbers, such as currency and the characters used for decimal mark and thousand separators, will display in Sheet To Go.

Slideshow To Go®

Slideshow To Go opens when you open a .ppt or .pptx file. While the file opens, a progress bar appears in the upper right-hand corner of the screen and some functions such as creating a new file are disabled. Some files may take longer than others due to their content and length.

Files Supported

Slideshow To Go opens:

- PowerPoint 1997–2003 (.ppt) and
- PowerPoint 2007–2010 slideshows (.pptx).

Some features available in Microsoft Excel are not available in Slideshow To Go. Unsupported features are not affected when a slideshow is edited or saved.

You can view and navigate within a slideshows while in slide view or outline view, and edit text in slides.

When you select a .ppt or .pptx file, Slideshow To Go opens and displays the slideshow in slide view.

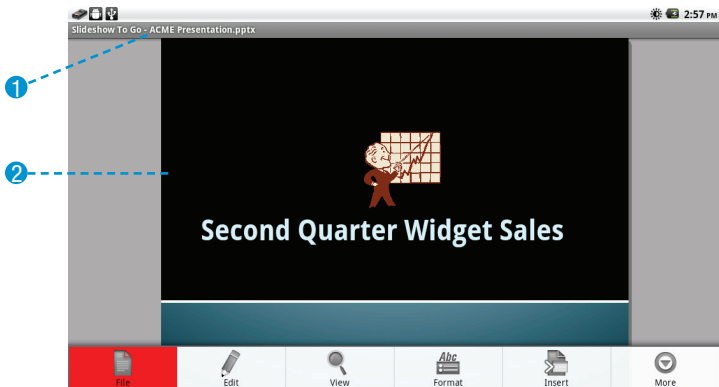

- 1 Filename
- 2 Current Slide

Opening and Saving Slideshows

You can perform many file functions within Slideshow To Go. You can use the File menu to open and save your files.

Opening the File Dialog

- 1 While you have another file open, press the Menu button.
- 2 Select File and the File dialog will appear.

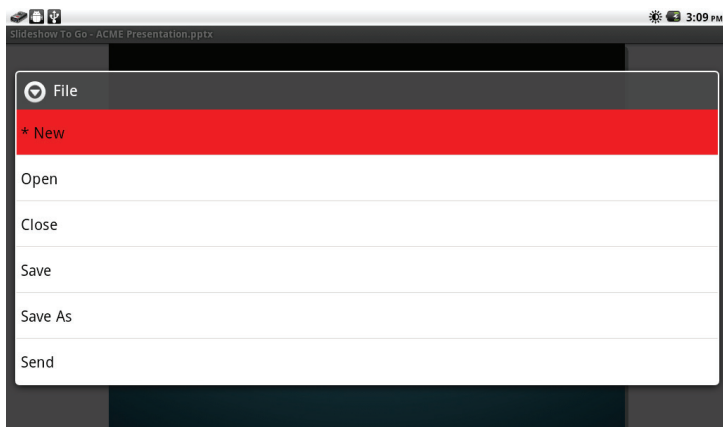

- 1 *New – Not supported in the standard version.
- 2 Open – Opens local files on the internal memory or SD Card.
- 3 Close – Closes the current file and returns you to Slideshow To Go.
- 4 Save – Saves your changes to the file.
- 5 Save As – Saves a copy of a file with changes under another filename and location.
- 6 Send – Not supported in the standard version.

Viewing and Navigating within Slideshow

There are two ways to view a slide show: slide view and outline view.

Switch between the Slide and Outline Views

- 1 Press the Menu button.
- 2 Select View.
- 3 Select Outline or Slide View and the view will change.

Moving From Slide to Slide

The current slide is displayed and you go to the next slide using the Touch Sensor or the Next Slide/Previous Slide options from the slide context menu.

Move to the Next Slide

Mouse Mode: Press and hold the Touch Sensor and a context menu opens. Select Next Slide.

Trackball Mode: Move your finger across the Touch Sensor from left to right.

Move to the Previous Slide

Mouse Mode: Press and hold the Touch Sensor and a context menu opens. Select Previous Slide.

Trackball Mode: Move your finger across the Touch Sensor from right to left.

The following is the context menu you receive when in Mouse Mode:

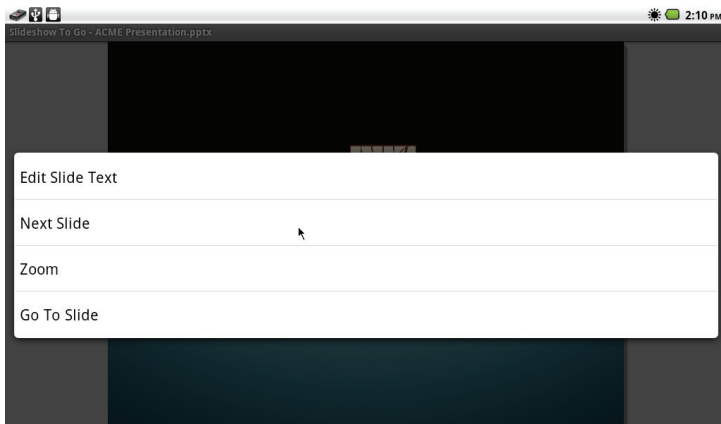

Viewing a Slide

- 1 Press the Menu button.
- 2 Select View.
- 3 Select Go To Slide and a list of the slide headings will appear.

The following is an example of the screen you receive with a list of slide headings:

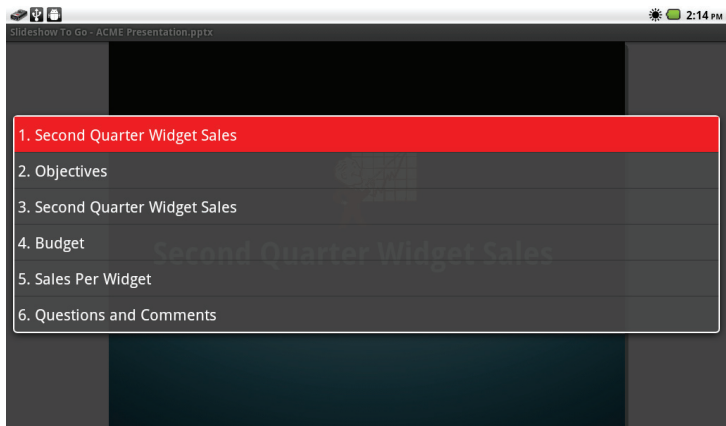

Zoom

While viewing slides in the outline view or slide view, you can zoom and scroll up or down the page.

Changing a Page Zoom Level

- 1 Open the Zoom dialog by pressing the Menu button.
- 2 Select View.
- 3 Choose the zoom level. 100% is the default.

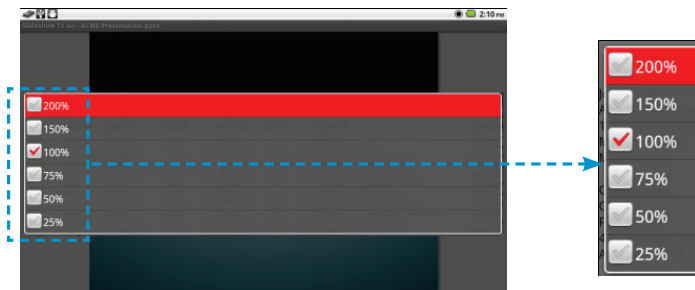

Panning Around the Page

Mouse Mode: In one motion, press and swipe your finger across the Touch Sensor in the direction you want to scroll the page. Tap the Touch Sensor to stop the page from scrolling further.

Trackball Mode: Move your finger across the Touch Sensor. Move the cursor up or down on the page.

Editing a Slide

You can make minor changes to slide text such as changing the slide title or updating text.

Editing Slide Text

While in Slide View:

- 1 Press and hold the Touch Sensor to open the context menu.

- 2 Select Edit Slide Text and the onscreen keyboard will open with the slide title in the text edit area.
- 3 Use the onscreen keyboard to edit the slide title.
- 4 Press the Back button to return to the Outline view.

While in Outline View

Mouse Mode: Using the Mouse Pointer, place the cursor on the same line as the text you want to edit. Press Menu and the onscreen keyboard will appear. Use the onscreen keyboard to modify the text.

Trackball Mode: Using the Touch Sensor, move the cursor to the line you want to edit. Press the Touch Sensor and the onscreen keyboard will appear with text. Use the onscreen keyboard to modify the text.

Finding Text in a Spreadsheet or Workbook

- 1 Press the Menu Button.
- 2 Select View.
- 3 Select Find and the Find dialog appears.
- 4 Press the Touch Sensor and the onscreen keyboard will appear.
- 5 Use the onscreen keyboard to enter search text and click Find. Press the Back button to exit the onscreen keyboard.

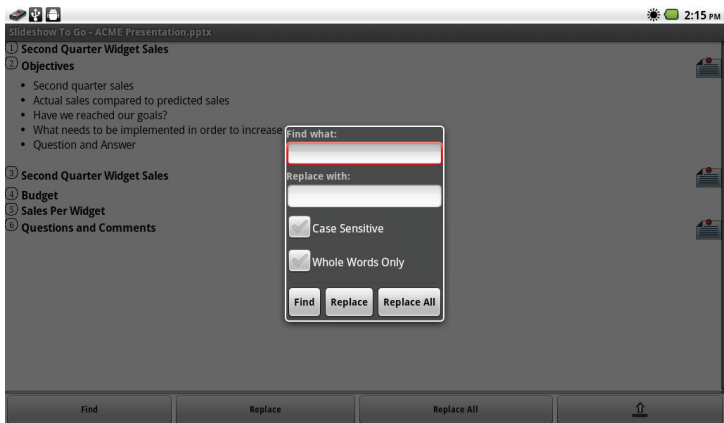

- 1 Find What – Enter the text or number you wish to find.
- 2 Replace with – Not supported in the standard version.
- 3 Case Sensitive – Matches the case for the Find What text.
- 4 Whole Words Only - Finds complete words only. For example, if you type “boat” and do not select Whole Words Only, Find What will find “boat”, “boathouse” and “sailboat”.

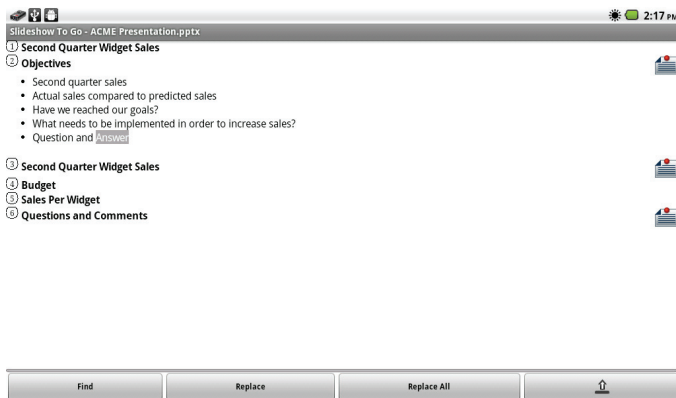

The Find toolbar appears at the bottom.

- 1 Find – Finds the next occurrence.
- 2 Replace – Not supported in the standard version.
- 3 Replace All – Not supported in the standard version.
- 4 Open Find dialog – Opens the Find dialog.

Selecting Text for Copy, Paste or Cut

Two Ways to Enter Selection Mode

Press and Hold the Touch Sensor:

- 1 Select the location in the slide text where you want to start your selection.
- 2 Press and hold the Touch Sensor and then a list will appear.
- 3 Select the Selection Mode option.

Menu, View, Select:

- 1 Select the location in the slide text where you want to start your selection.
- 2 Press Menu.
- 3 Select View.
- 4 Select the Selection Mode option.

Selecting Multiple Lines of Text

Once you enter Selection Mode, if you want to select multiple lines of text:

- 1 Select the first line of text.
- 2 Press and hold the Touch Sensor and the context menu appears.
- 3 Choose Selection Mode.
- 4 Move the selector to grow or shrink the selection area.
- 5 Press and hold the Touch Sensor for more options or press Back button to exit the selection mode.

Selection Mode Option Menu



- 1 Cancel Selection – Exits Selection Mode.
- 2 Cut – Copies the selected text. Once you paste the text into another slide or in another area of the current slide, the text is deleted.

- 3 Copy – Copies the selected text so you can paste it in a new slide or another area of the current slide.
- 4 *Delete Slide – Not supported in the standard version.

Advanced Editing

You can copy and paste data from one area to another, or you can cut and paste and move data from one area to another.

Important: You can use the copy, cut and paste options for the slide title text and the text on the main body of the slide (such as bullet points on a slide).

Copy and Paste

- 1 Place the cursor before the text you want to copy.
- 2 Press the Menu button.
- 3 Select Move Cursor Over Text to highlight the text you want to copy.
- 4 Press the Menu button.
- 5 Select Edit.
- 6 Select Copy.
- 7 Move to the area in the text where you want to paste the text.
- 8 Press the Menu button.
- 9 Select Edit.
- 10 Select Paste.

Cut and Paste

- 1 Place the cursor before the text you want to cut.
- 2 Press the Menu button.
- 3 Select Move Cursor Over Text to highlight the text you want to cut.
- 4 Press the Menu button.
- 5 Select Edit.
- 6 Select Cut.
- 7 Move the cursor to the place in the text where you want to paste the text.

- 8 Press the Menu button.
- 9 Select Edit.
- 10 Select Paste.

Note: The selected text is deleted after the paste function is executed.

Locked or Read Only Files

Slideshow To Go locks a file when the file contains objects or formulas that are not supported. When the file is locked, you cannot edit or save the file.

Slideshow To Go Preferences

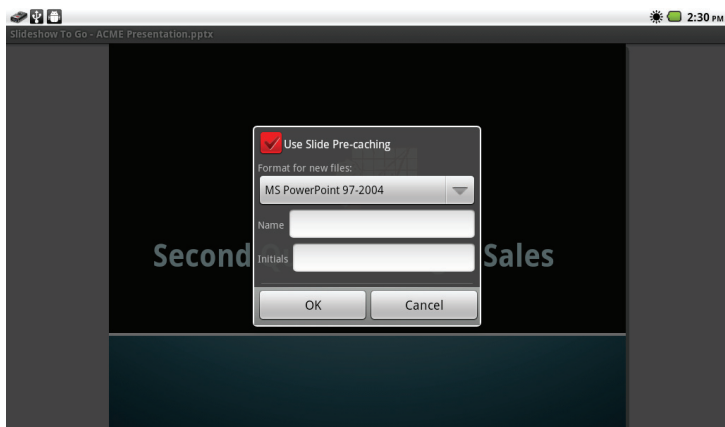

- 1 Use Slide Pre-caching – Pre-loads the slides before starting the presentation for smooth transition from slide to slide.
- 2 Name and Initials – When saving a new file, Slideshow To Go attaches a name and initials to the new file to distinguish it from existing files.

PDF to Go

PDF To Go opens when you open a .pdf file. While the file opens, a progress bar appears in the upper right-hand corner of the screen. Some files may take longer than others due to their content and length. You can view and navigate within pdf files. When you select a pdf file, PDF To Go opens and displays the first page in the document.

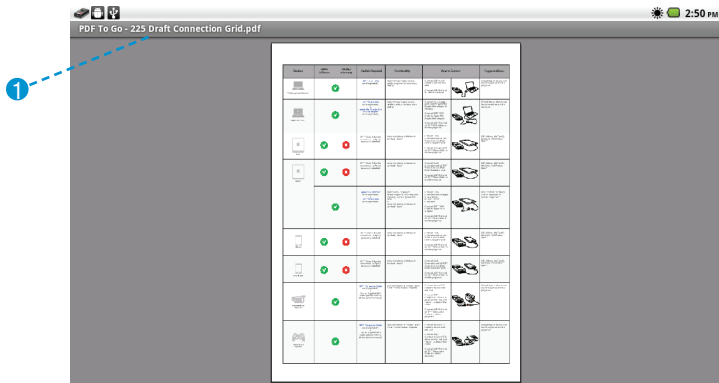

- 1 PDF File Name – Name of the PDF file you are viewing.

Opening and Closing PDF files

You can use the File dialog to open and close your files.

- 1 While you have another file open, press the Menu button.
- 2 Select File and the File dialog will appear.
 - Select Open to open a local file in internal memory or from the SD card.
 - Select Close to exit the current file.

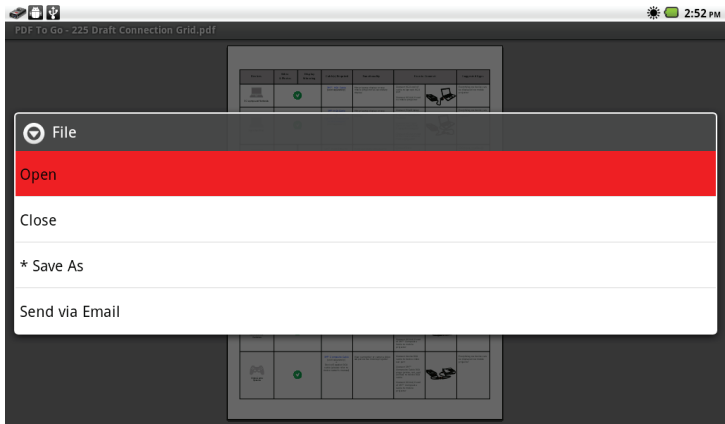

- 1 Open – Opens local files on the internal memory or SD Card.
- 2 Close – Closes the current file and returns you to Documents To Go.
- 3 *Save As – Not supported in the standard version.
- 4 Send via Email – Not supported in the standard version.

Viewing and Navigating within a PDF File

You can page through, zoom, or rotate the pages while viewing a PDF document.

While viewing a document, you can zoom and scroll up or down the page.

Changing the Page Zoom Level

- 1 Open the Zoom dialog by pressing the Menu button.
- 2 Select View.
- 3 Choose the zoom level. 100% is the default.

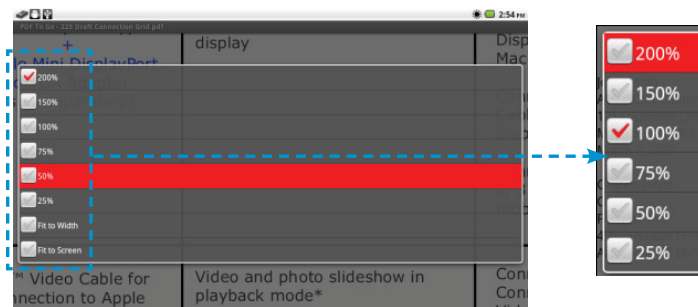

Scrolling Up or Down the Page

Mouse Mode: In one motion, press and swipe your finger from across the Touch Sensor in the direction you want to scroll the page. Tap the Touch Sensor to stop the page from scrolling further.

Trackball Mode: Move your finger across the Touch Sensor and move the cursor up or down on the page.

Rotating Pages

When the PDF document is not in the orientation you want to view, you can rotate the document 90 degrees to the left or right or rotate the document 180 degrees.

- 1 Press Menu.
- 2 Select View and the View option menu appears.
- 3 Select Rotate.
- 4 Select Rotate left, Rotate Right, or Rotate 180. The entire PDF document will rotate in the direction you chose.
- 5 Press Back to exit Rotate.

Fun Pack

The Fun Pack is a set of backgrounds for special occasions and games. When you click on the Fun Pack icon, the main menu appears.



Animation and Pictures

- 1 Click the Animations & Pictures icon to access animations and pictures for a variety of events.



- Click the event for which you want animations and pictures. A menu appears with the animations and pictures for the selected event. The example below shows the menu that appears when you select Birthdays.

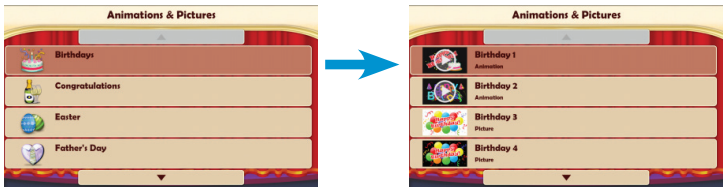

Picture Guessing Game

- Click the Picture Guessing Game icon.

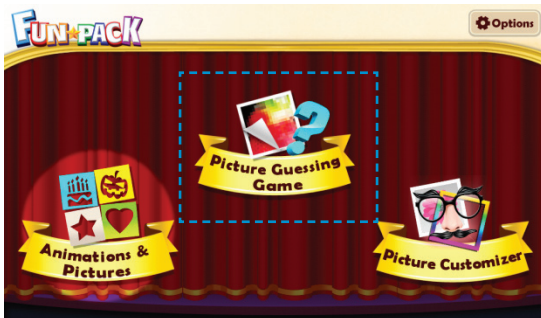

- Choose a photo album from a folder on your ID card.

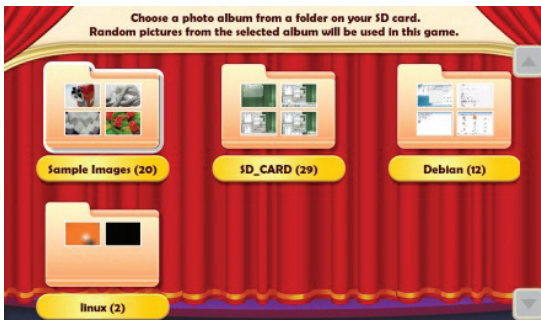

- 3 Play the game. When the timer is done before you identify the photo, the Time's up! dialog appears. Click OK.

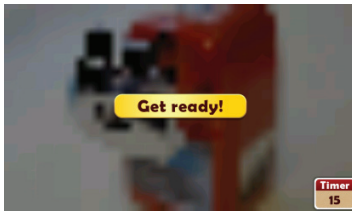

Timer for guessing what the picture is.

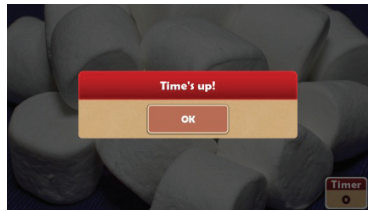

Click **OK** when the Time's Up! dialog appears.

- 4 Click Next to continue to the next picture.

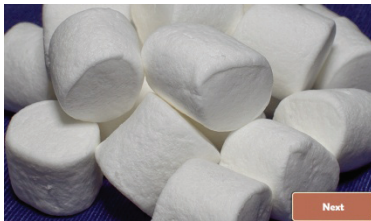

Picture Customizer

- 1 Click the Picture Customizer icon.

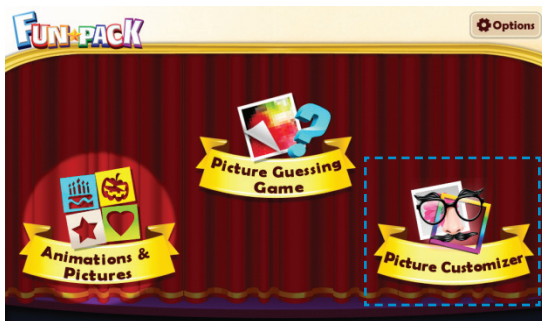

- 2 Click to choose your picture.

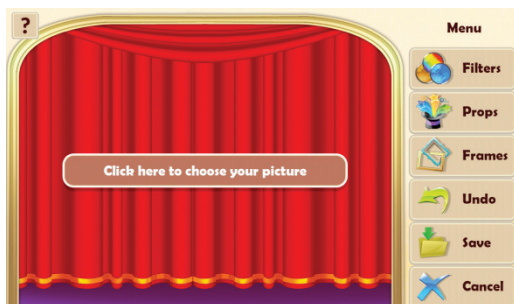

Picture Customizer Help

You can access help for Picture Customizer by clicking the question mark in the upper left-hand corner.

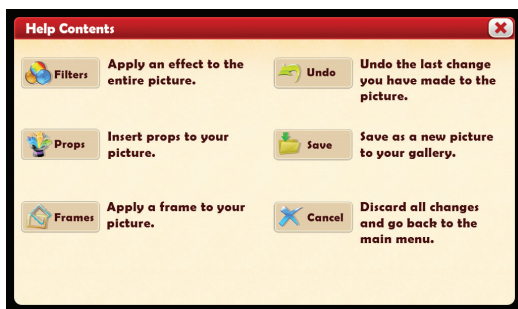

- 1 Filters – Apply a sepia, mosaic or charcoal filter. You can also select None.
- 2 Props – Insert props into your picture. You can select an existing prop to edit or select a new prop.
- 3 Frames – Select a photo frame. You can also select None.
- 4 Undo – Undo the last change you made to the picture.
- 5 Save – Saves the new picture to your gallery.
- 6 Cancel – Discards all changes and goes back to the main menu.

Cannon Ball Pro

Cannonball Pro is a game where you shoot the avatar image out of a cannon to destroy structures in order to earn points.

Open Cannonball Pro

Click the Cannonball Pro icon to open the game.

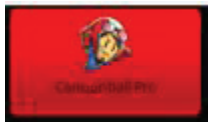

Cannonball Pro Menu



- 1 Play – Starts the game.
- 2 Select Avatar – Allows you to select the Avatar image you want to shoot from the cannon.
- 3 Achievements – Shows the highest scores for the game.
- 4 Instructions – Provides detailed game instructions.
- 5 Options – Sets the game options.
- 6 About – Shows the current version of the game.

Settings

Settings provide a way for you to configure the projector brightness and how it operates. Many applications also have their own settings; for details, see the section for each individual application.

Opening Settings

- Press the Home, press Menu, and then select Settings.
or
- Select the Launcher, and then select Settings.

Touch Sensor

The Touch Sensor operates in two modes: mouse mode or trackball mode. In Touch Sensor, you can put a checkmark beside Mouse Mode if you want the Touch Sensor to operate like a Mouse. Uncheck Mouse Mode if you want to use trackball mode.

Sound

Use the Sound settings to change the volume for media or alarms or turn on or off the audible selections. Audible selection plays a sound every time you select items in the user system.

Volume

When you select Volume, a dialog appears and provides volume controls for media (such as music and videos) and alarms.

Display

You can use Display settings to configure the projector brightness, and other screen settings.

Brightness

Brightness in Display settings affects the brightness of the projected image. When the MP220 is turned on for the first time, Brightness is set to Minimum. The image brightness increases by 30%, when you change Brightness from Minimum to Maximum. The noise from the cooling fans will increase when Brightness is set to Maximum.

To change brightness:

- 1 Select Display.
- 2 Select Brightness.
- 3 Select Minimum or Maximum.

Gamma

Gamma changes the projected image relative to the input signal or image. There are three settings: Business, Photo, and Video.

Animation

Animation controls the transition between screens and effects when opening menus and selecting items. You can choose to turn off some or all animations.

- Some Animation - Turns off the screen to screen transitions.
- No animations - Turns off all other animations.

NOTE: Animation in some applications is not controlled by this setting.

Screen Timeout

You can set how long to wait before the projector darkens the screen and then turns off the projector lamp. The projector turns off the projector lamp after the specified time has passed without activity. Some applications (such as the video player app and pass through app) will prevent the projector from turning off the lamp after the specified time has passed.

Horizontal and Vertical Flip

Horizontal and Vertical Flip change the orientation of the image for use as a rear screen projector, ceiling mounted projector, or folded optics system.

Location and Security

The features in Location and Security are not used by the projector.

Application Settings

Application Settings provide a way for you to view a list of applications and services installed on the projector, manage their data and force them to stop.

Application Settings Screen

Unknown Sources

Check this when you want to update the system or install an application.

Manage Applications

This screen shows you a list of applications and other software installed on your projector and their sizes. At the top of the screen are four tabs. Each tab shows you a specific filter list of the applications.

- Download tab shows you all of the applications that you have installed.
- Running tab shows you all of the applications currently running.
- All tabs show you all of the applications on the projector.
- SD card tab shows you all applications installed onto the SD card.

To sort the application list:

- 1 Press Menu.
- 2 Select Sort By Size.
- 3 Press Menu and Select a-z.

Running Services

The Running Services screen shows you a list of applications or portions of an application that provides services to other applications, and runs even when the main application is not. Each service has a gray bar above it which shows the processes needed and memory used by the service. Under the service's name, you will find text that tells you what you can do if you select it.

Development

Opens the Development screen.

Application Info Screen

When you select an application in the Manage Applications screen, the Application Info screen will open. There are four sections on this screen:

- Version – Displays the version of the application.
- Force Stop – Stops the application. The application will not start again unless you or another application or service opens it.

- Uninstall – Removes the application from the projector.
- Storage, Cache, Launch By Default, and Permissions –
 - Storage – Provides details about the amount of memory the application and its data uses. You can uninstall the application, clear data, or move the application to the SD card to free up memory.
 - Cache – Displays the amount of data stored in cache by the application.
 - Launch By Default – Allows you to launch the application by default, or launch the application for certain file types. You can clear the file type settings here.
 - Permissions – Lists areas where the application has permission to access.

The availability of these actions will depend on the application.

Privacy

The Privacy screen has a setting for resetting the factory data.

Factory data reset

When you select Factory data reset, the projector will erase all personal data from the projector storage, such as applications you have installed, and date and locale information. It will not erase system software, updates or any files on the projector's internal memory or SD card.

SD card and local storage

The SD card & local storage settings allow you to monitor the memory usage of the internal memory and SD card. There are three sections on this screen:

- SD Card – Lists the total and available space on the SD card inserted into the SD slot on the projector.
 - Unmount/Mount SD card – Mounts (connects) or unmounts (disconnects) the SD card.
 - Format SD Card – Formats the SD card.
- Device Media Storage – Lists total and available memory space on the projector internal memory.

- **Internal Device Storage** – Displays the amount of memory available for additional applications. The Internal Device Storage is the memory used by the operating system, applications and data stored by both.

Language and Keyboard

Within the Language and Keyboards settings, you can select the language that the user system text displays and configure the onscreen keyboard.

Select Language

- 1 When you select Select Language, the Language screen appears.
- 2 Select the language you wish the projector to display. The projector must be turned off and then back on after this is changed. Otherwise, some text in the menus and screen will not be updated to the new language.

Date and Time Settings

This sets the projector's date and time and how it is displayed. Additionally you can set the time zone.

Set Date

Select Set Date to set the date.

Set time zone

Select time zone and choose your time zone.

Set time

Select Set Time and set the time.

Use 24-hour format

You can change the time format to 24-hour time. The 24-hour time format displays the time, such as 1:00 pm, as 13:00.

Select date format

Formats the way the date is displayed.

About

About lists information about the projector such as model number and operating system version.

Legal Information

Opens the Legal Information screen. You can view the open source license.

Model Number

Displays the model number for the projector.

Android Version

Displays the operating system version.

Kernel Version

The kernel is the software that acts as an interface between the projector's hardware and the graphical user interface. The kernel software is specific to the projector. This line tells you the version that is currently running.

Build Number

When software is made (or compiled), a build number is assigned to it. This provides you and customer support agents with accurate information about the version of the operating system loaded onto the projector.

Serial Number

This is the serial number of the projector. This same serial number is located on a label beneath the battery.

Optical Engine Serial Number

This is the serial number for the installed optical engine.

Over-temperature errors

If the projector over heats, the overheating occurrence will be recorded here.

Limited Warranty

This warranty applies to the continental US only. The warranty terms, conditions, remedy and limitation may vary in other countries. Contact your local 3M Company for warranty information.

- The 3M™ Pocket Projector MP220 (the “3M product”) is warranted to be free from defects in material or manufacture for a period of 1 year from the date of purchase.
- All other accessories included with the 3M product are warranted to be free from defects in material or manufacture for a period of 1 year from the date of purchase.
- Optional product accessories that are not sold as part of the 3M product are subject to individual warranties.

THE WARRANTIES STATED ABOVE ARE EXCLUSIVE AND ARE MADE IN PLACE OF ANY AND ALL WARRANTIES, EXPRESS OR IMPLIED WARRANTIES OR CONDITIONS, INCLUDING ANY IMPLIED WARRANTY OF MERCHANTABILITY OR FITNESS FOR A PARTICULAR PURPOSE, OR ANY INDUSTRY PRACTICE OR CUSTOM OR TRADE USAGE.

In the event the 3M product fails to conform to the above stated warranties within the applicable warranty period, your exclusive remedy shall be, at 3M's option, to replace or repair the 3M product or to refund the purchase price of the 3M product. All replaced parts or products become property of 3M. If the product is repaired, 3M will repair the defective part(s) with a new or used part(s). If the 3M product is replaced, 3M will replace the 3M product with the same or equivalent model and with a new or refurbished 3M product. In the case of an approved warranty claim, the replacement 3M product will carry only the remaining term of the original 3M product's warranty period as stated above. For warranty service, you must provide proof of the date of the original purchase else the manufacturing code date will be used to establish the start date of the warranty. The following are exclusions to the above listed warranty:

- a This warranty does not cover 3M product that is modified or damaged through improper storage, misuse, abuse, accident, vandalism, improper installation, neglect, improper shipping, damage caused by acts of war, disasters such as fire, flood, and lightning, improper electrical current, software problems, interaction with non-3M products, or service other than by an 3M Authorized Service Provider, neglect or mishandling by any person. Normal wear and tear is not covered under warranty.
- b 3M product is designed to operate in the typical indoor environment. This warranty does not cover 3M product used outside of the following circumstances:
 - 100V–240V AC, 50/60 Hz
 - 0°–35°C (32°–95°F)
 - 10–80% RH (without condensation)
 - 0–1829 m (0–6000 feet) above sea level
- c The air intake and exhaust vent must be clear of obstructions. Inadequate air ventilation will cause the 3M product to malfunction or will cause damage to the 3M product which will void the warranty.
- d This warranty does not cover any additional costs including, but not limited to, those associated with removal, cleaning or installation of the 3M product, adjustments, (mechanical or electronic) made to the 3M product.
- e This warranty covers only normal use of the product. 24-hour-per-day or other excessive continual use causes strain and is not considered normal use.
- f This warranty does not cover consumables (e.g., batteries).
- g This warranty is not transferable.
- h 3M is not responsible for warranty service should the 3M label or logo or the rating label or serial number be removed unless otherwise stated in writing for the purposes of private labeling for partnership requirements.

- i This warranty does not cover postage, insurance, or shipping costs incurred in presenting your 3M product for warranty service. Said costs are the customer's responsibility. If a claimed defect cannot be identified or reproduced in service, the customer may be held responsible for cost incurred. Should your warranty upgrade include a "change out" service and the claimed defect cannot be identified or reproduced by the technician, the customer will be responsible for call out costs.

FAILURE TO FOLLOW THE INSTRUCTIONS CONTAINED IN THE APPROPRIATE 3M PRODUCT MANUAL OR TO USE THE 3M PRODUCT IN ACCORDANCE WITH 3M'S INTENDED USE STATEMENT, WILL VOID ALL WARRANTIES AND LIMITED REMEDIES. EXCEPT AS SPECIFICALLY STATED IN THE APPLICABLE 3M PRODUCT MANUAL, 3M SHALL NOT BE LIABLE FOR ANY INDIRECT, INCIDENTAL, SPECIAL OR CONSEQUENTIAL DAMAGES (INCLUDING, BUT NOT LIMITED TO, LOSS OF PROFITS, REVENUE OR BUSINESS) RESULTING FROM, OR IN ANY WAY RELATED TO PERFORMANCE, USE OR INABILITY TO USE ANY OF THE 3M PRODUCT. This limitation applies regardless of the legal theory upon which damages are sought. For warranty support, please call or write your local 3M office or a 3M Authorized Service Provider to obtain an RMA # (Return Material Authorization number) before returning the product. If you are inside the Continental United States of America, please contact 3M Customer Service at 1-866-631-1656 or email meetings@mmm.com.

What 3M Will Do To Correct Problems:

If your 3M product requires service, 3M will ask you to bring or send the 3M product, securely packaged in its original container or equivalent, along with proof of the date of original purchase, to your 3M Service Dealer or 3M Service Center.

- 3M will, at its option, repair or replace the defective unit without charge for parts or labor. Return of the 3M product will be at 3M's expense.
- When warranty service involves the exchange of the 3M product or of a part, the item replaced becomes 3M property.
- The exchanged 3M product or part may be new or previously refurbished to the 3M standard of quality, and at 3M's option, the replacement may be another model of like kind and quality.

- 3M's liability for replacement of the warranted 3M product or part will not exceed the original retail selling price of the 3M product. Exchange or replacement products or parts assume the remaining warranty period of the product covered by this limited warranty.

FCC STATEMENT - CLASS B

This equipment generates, uses and can radiate radio frequency energy, and if not installed and used in accordance with the instruction manual may cause interference to radio communications. It has been tested and found to comply with the limits for a Class "B" computing device pursuant to Subpart B of Part 15 of the FCC Rules, which are designed to provide reasonable protection against such interference when operated in a residential installation. However, there is no guarantee that interference will not occur in a particular installation. If this equipment does cause harmful interference to radio or television reception, which can be determined by turning the equipment off and on, the user is encouraged to try to correct the interference by one or more of the following measures:

Reorient or relocate the receiving antenna.

- Increase the separation between the equipment and receiver.
- Connect the equipment into an outlet on a circuit different from that to which the receiver is connected.
- Consult the dealer or an experienced radio/TV technician for help.

NOTICE: This Class B digital apparatus complies with Canadian ICES-003.

Cet appareil numérique de la classe B est conforme à la norme NMB-003 du Canada.

INSTRUCTIONS TO USERS: This equipment complies with the requirements of FCC equipment provided that the following conditions are met. If the cables include a EMI ferrite core, attach the ferrite core end of the cable to the projector. Use the cables which are included with the projector or specified.

Note: Changes or modifications not expressly approved by the party responsible for compliance could void the user's authority to operate the equipment.

CE Statement

ElectroMagnetic Compatibility Statement: Meets 2004/108/EC Directive

Low Voltage Directive: Meets 2006-95-EC Directive.

WEEE Statement

The following information is only for EU-members States: The mark shown to the right is in compliance with Waste Electrical and Electronic Equipment Directive 2002/96/EC (WEEE). The mark indicates the requirement NOT to dispose the equipment as unsorted municipal waste, but use the return and collection systems according to local law.



RoHS Statement

3M Mobile Interactive Solutions can provide RoHS certification for products meeting the RoHS directive.¹

European (EU) Restriction of Hazardous Substances (RoHS) Directive, 2002/95/EC, 1 RoHS compliant means that the product or part does not contain any of the substances in excess of the following maximum concentration values in any homogeneous material, unless the substance is in an application that is exempt under RoHS, as amended:(a) 0.1% (by weight) for lead, mercury, hexavalent chromium, polybrominated biphenyls or polybrominated diphenyl ethers; or (b) 0.01% (by weight) for cadmium. This information represents 3M's knowledge and belief, which may be based on information provided by third party suppliers to 3M.

Copyright, Trademarks and Properties Notices

3M and the 3M logo are trademarks of 3M Company. Used under license in Canada. Microsoft, Windows, Windows XP, Windows Vista, Word, Excel, and PowerPoint are either registered trademarks or trademarks of Microsoft Corporation in the United States or other countries.

Bluetooth and the Bluetooth logo are trademarks owned by Bluetooth SIG, Inc. Wi-Fi is a registered trademark of the Wireless Fidelity Alliance, Inc.

microSD is a trademark of SD Card Association. All other trade names referenced are the service marks, trademarks or registered trademarks of their respective companies.

Video and Audio Decoder Notices

MPEG-4 NOTICE

THIS PRODUCT IS LICENSED UNDER THE MPEG-4 VISUAL PATENT PORTFOLIO LICENSE FOR THE PERSONAL AND NON-COMMERCIAL USE OF A CONSUMER FOR (i) ENCODING VIDEO IN COMPLIANCE WITH THE MPEG-4 VISUAL STANDARD ("MPEG-4 VIDEO") AND/ OR (ii) DECODING MPEG-4 VIDEO THAT WAS ENCODED BY A CONSUMER ENGAGED IN A PERSONAL AND NONCOMMERCIAL ACTIVITY AND/OR WAS OBTAINED FROM A VIDEO PROVIDER LICENSED BY MPEG LA TO PROVIDE MPEG-4 VIDEO. NO LICENSE IS GRANTED OR SHALL BE IMPLIED FOR ANY OTHER USE. ADDITIONAL INFORMATION INCLUDING THAT RELATING TO PROMOTIONAL, INTERNAL AND COMMERCIAL USES AND LICENSING MAY BE OBTAINED FROM MPEG LA, LLC. SEE [HTTP://WWW.MPEGLA.COM](http://www.MPEGLA.COM).

AVC VIDEO NOTICE

THIS PRODUCT IS LICENSED UNDER THE AVC PATENT PORTFOLIO LICENSE FOR THE PERSONAL AND NONCOMMERCIAL USE OF A CONSUMER TO (i) ENCODE VIDEO IN COMPLIANCE WITH THE AVC STANDARD (“AVC VIDEO”) AND/OR (ii) DECODE AVC VIDEO THAT WAS ENCODED BY A CONSUMER ENGAGED IN A PERSONAL AND NONCOMMERCIAL ACTIVITY AND/OR WAS OBTAINED FROM A VIDEO PROVIDER LICENSED TO

PROVIDE AVC VIDEO. NO LICENSE IS GRANTED OR SHALL BE IMPLIED FOR ANY OTHER USE. ADDITIONAL INFORMATION MAY BE OBTAINED FROM MPEG LA, L.L.C. SEE [HTTP:// WWW.MPEGLA.COM](http://www.mpegla.com)

MPEG LAYER-3 NOTICE

Supply of this product does not convey a license nor imply any right to distribute MPEG Layer-3 compliant content created with this product in revenue-generating broadcast systems (terrestrial, satellite, cable and/or other distribution channels), streaming applications (via Internet, intranets and/or other networks), other content distribution systems (payaudio or audio-ondemand applications and the like) or on physical media (compact discs, digital versatile discs, semiconductor chips, hard drives, memory cards and the like). An independent license for such use is required. For details, please visit <http://mp3licensing.com>.