



Remote Management Card RMCARD205 / RMCARD305

User's Manual

The Remote Management Card allows a UPS system and environmental sensor to be managed, monitored, and configured.

TABLE OF CONTENTS

Introduction	3
Installation Guide	6
Web Interface	10
Command Line Interface	35
Reset to Factory Default Setting / Recover from a Lost Password	53
RMCARD Firmware Upgrade	54
Troubleshooting	60
Conformance Approvals	61
Appendix 1: IP Address Identification for CyberPower Remote Management Card	62
Appendix 2: How to Configure a RMCARD User Account in Authentication Servers ..	64
Appendix 3: UPS Firmware Upgrade	65
Appendix 4: Software Support	65
Appendix 5: RMCARD Adapter Guide	68

Introduction

Overview

The CyberPower Remote Management Card allows for remote monitoring and management of a UPS attached to a network. After installing the hardware and configuring an IP address, the user can access, monitor, and control the UPS from anywhere in the world! Simply use a web browser, command line interface or SSH client to access your UPS. Servers and workstations can be protected by the UPS utilizing PowerPanel® Business Edition Client to gracefully shutdown when signaled by the Remote Management Card.

Features

- Real time UPS monitoring
- Remote management and configuration of the UPS via Web Browser, NMS or Command Line Interface (SSH and Telnet)
- Local management and configuration of the UPS via serial connection
- Trigger servers/workstations to shutdown during a power event to prevent data loss or corruption
- Schedule shutdown/start-up/reboot of the UPS remotely
- Event logging to trace UPS operational history
- Graphic data logging to analyze power conditions
- Save and restore configuration settings
- Event notifications via Email, SNMP traps, Syslog, and SMS
- Remote UPS Firmware Upgrade via Web Interface and FTP in Select UPS Models
- Support IPv4/v6, SNMPv1/v3, HTTP/HTTPS, DHCP, NTP, DNS, SMTP, SSH, Telnet, FTP and Syslog protocol
- Support Email Secure Authentication Protocols: SSL, TLS
- Support External Authentication Protocols: RADIUS, LDAP, LDAPS, Windows AD
- SNMP MIB available for free download
- User upgradeable firmware via FTP, CyberPower Upgrade and Configuration Utility and Secure Copy Protocol (SCP)
- Upgrade firmware and upload configuration files to multiple units at once
- Multi-language user interface
- Quick installation
- Hot-swappable
- Cisco EnergyWise Compatible
- Support Environmental Sensor (ENVIROSENSOR)

System Requirements

- A 10/100Mbps Ethernet connection to an existing network
- Web Browser or SSH client
- (Optional) NMS (Network Management System) compliant with SNMP

Application

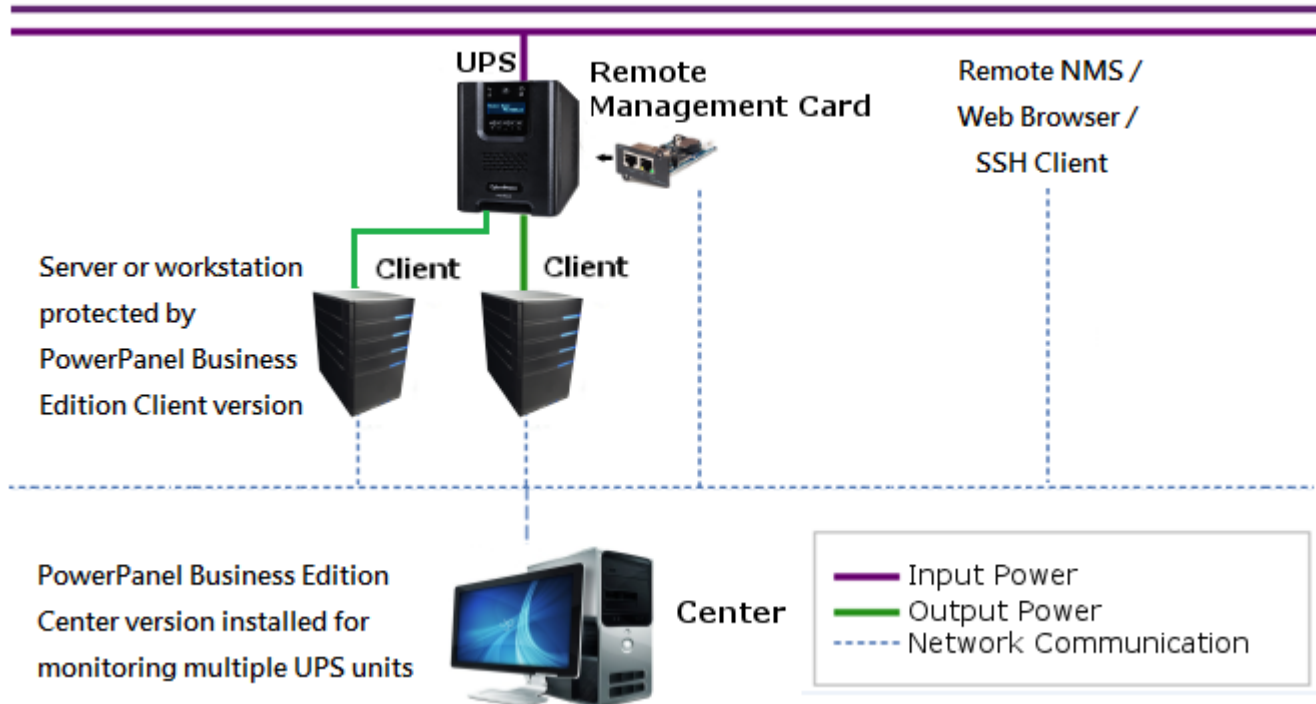

Unpacking

Inspect the Remote Management Card upon receipt. The package should contain the following:

- CyberPower Remote Management Card
- RJ45/DB9 Serial Port Connection Cable
- Quick Start Guide
- Spare Jumper
- RMCARD205 Front Panel (with RMCARD305 only)

Front Panel RMCARD205

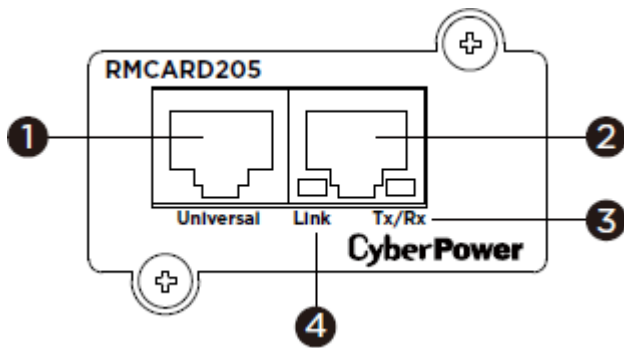

1. Universal Port
2. Ethernet Port
3. Tx/Rx Indicator
4. Link Indicator

RMCARD305

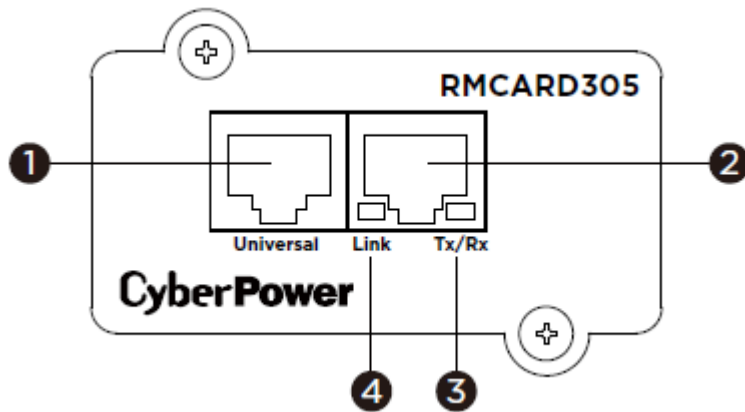

LED Status Indicators

Link LED	Condition
Off	The Remote Management Card is not connected to the Network/ or the Remote Management Card power is off
On (Yellow)	The Remote Management Card is connected to the Network
Tx/Rx LED	
Off	The Remote Management Card power is off
On (Green)	The Remote Management Card power is on
Flashing (Green)	- Receiving/transmitting data packet - Reset finished

Installation Guide

Step 1. Hardware Installation

Note: The CyberPower Remote Management Card is hot-swappable, so you do not need to turn off the UPS to install it.

1. Remove the two retaining screws from the expansion slot and remove the cover.
2. Install the CyberPower Remote Management Card into the expansion slot.
3. Insert and tighten the retaining screws.
4. Connect an Ethernet cable to the Ethernet port of the CyberPower Remote Management Card.
5. (*Optional*) To connect an environmental sensor, use a RJ45 Ethernet cable. Connect one end to the Universal port on the RMCARD and the other end into the sensor. For more information, please see the ENVIROSENSOR user's manual.

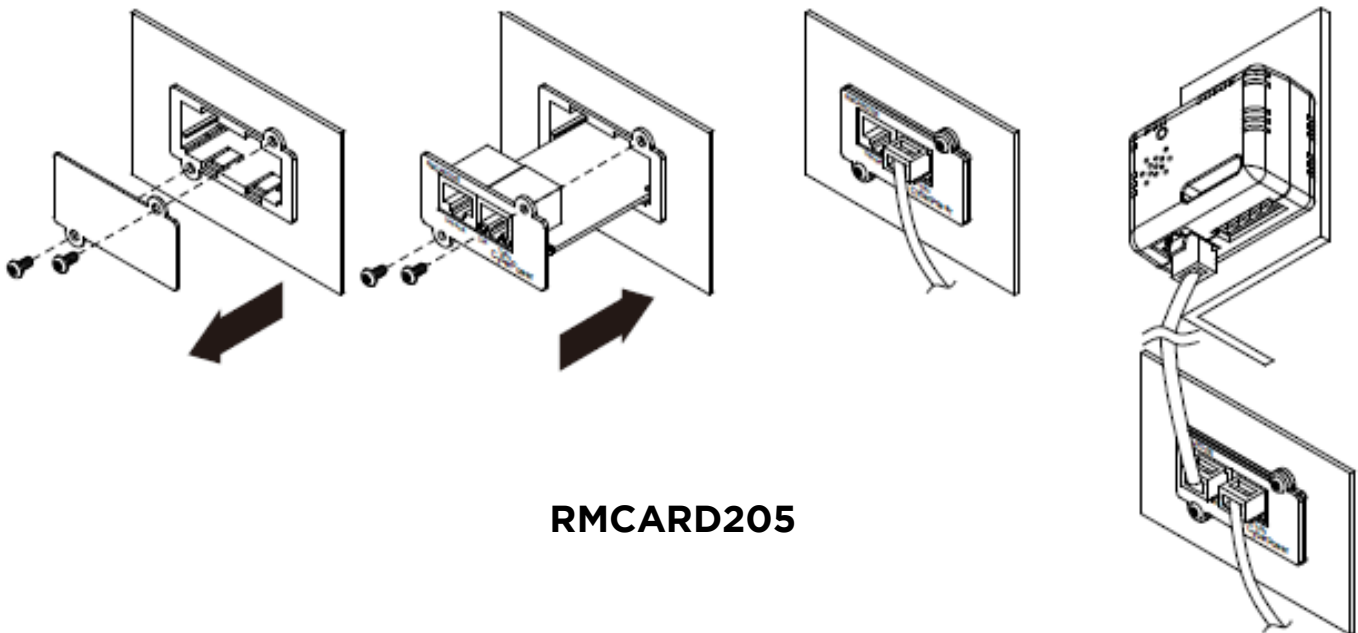

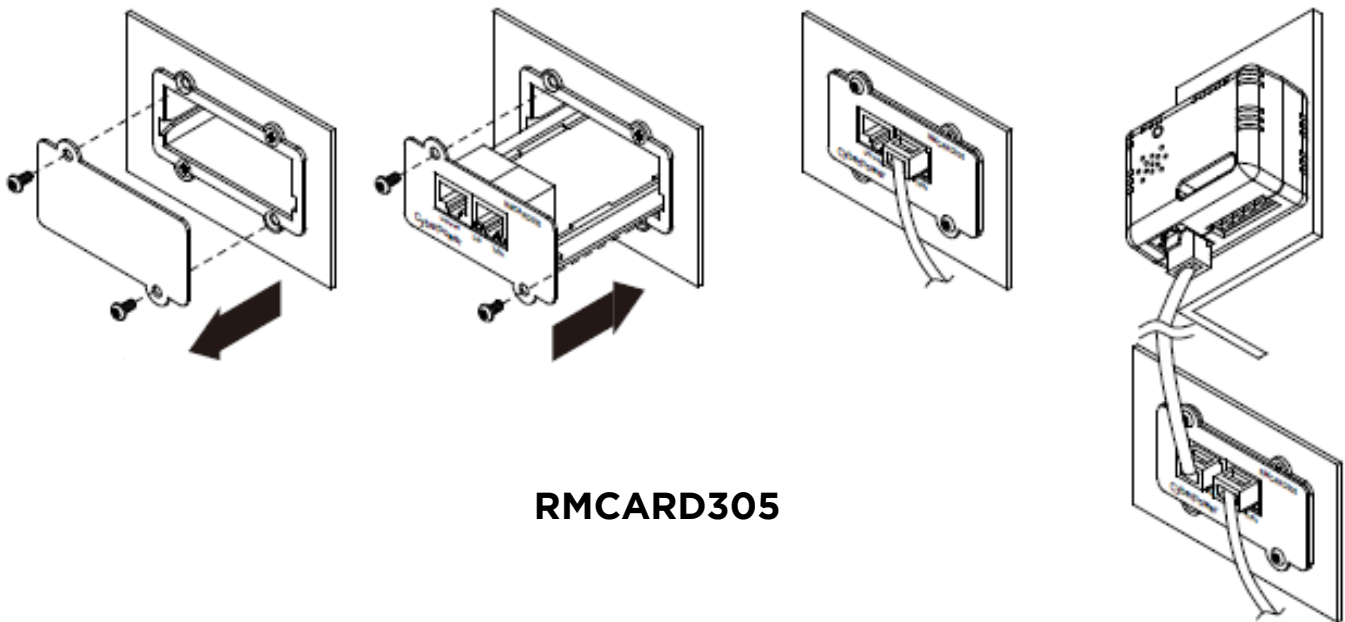

RMCARD305

Step 2. Configure the IP address for the CyberPower Remote Management Card

Note: These instructions are for Windows OS. For other OS please refer to Appendix 4.

Method 1: Using the Power Device Network Utility

1. Install the Power Device Network Utility available for download at www.cyberpowersystems.com.
2. After installation completes, run the "Power Device Network Utility".
3. The main window of the Power Device Network Utility program is shown in Figure 1. The configuration tool will display all CyberPower Remote Management devices present on the local network subnet. The "Refresh" button is used to search the local network subnet again.

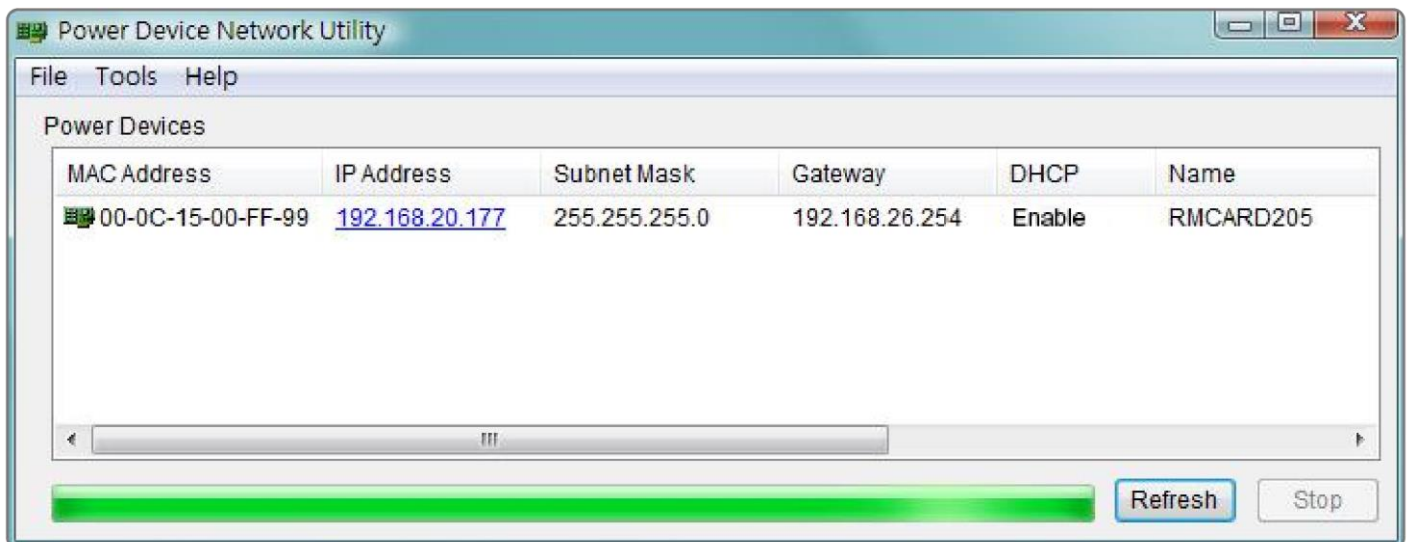
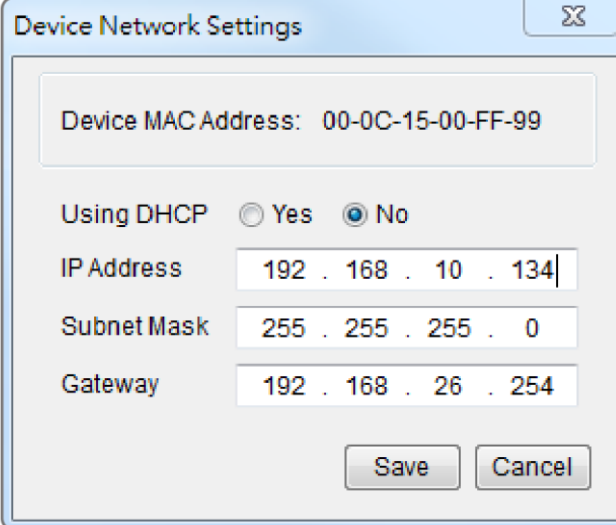

Figure 1. The main window of the "Power Device Network Utility" program.

4. Select the Remote Management Card you are setting up. Click on the Tools menu and select “Device Setup” or double click the device you want to configure.
5. You can modify the IP Address, Subnet Mask, and Gateway address for the Device MAC Address listed in the Device Network Settings window, as shown in Figure 2. The factory default IP Address is 192.168.20.177 and the default Subnet Mask is 255.255.255.0.



Device Network Settings

Device MAC Address: 00-0C-15-00-FF-99

Using DHCP Yes No

IP Address 192 . 168 . 10 . 134

Subnet Mask 255 . 255 . 255 . 0

Gateway 192 . 168 . 26 . 254

Save Cancel

Figure 2. The Device Network setting window.

6. Modify the IP, subnet mask or gateway address. Enter the new addresses into the corresponding fields and then click “Save”.
7. You will need to enter a User Name and Password for the Remote Management Card in the authentication window, as shown in Figure 3.
 - Default user name: **cyber**
 - Default password: **cyber**

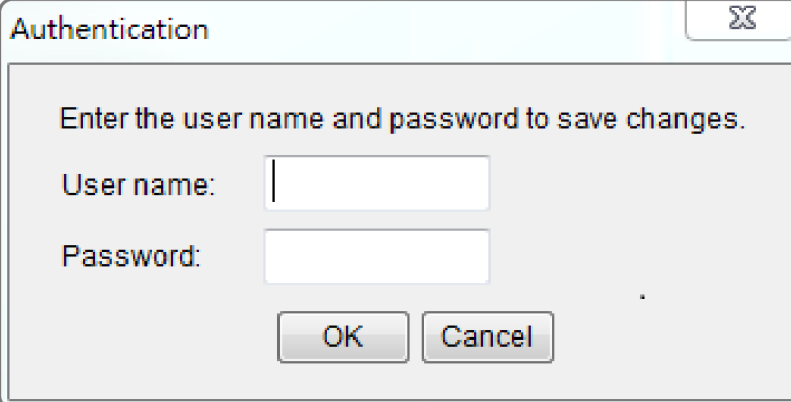

Authentication

Enter the user name and password to save changes.

User name:

Password:

OK Cancel

Figure 3. Authentication window.

8. If the IP address change is successful, you will see a message confirming the IP set up is OK, as shown in Figure 4.

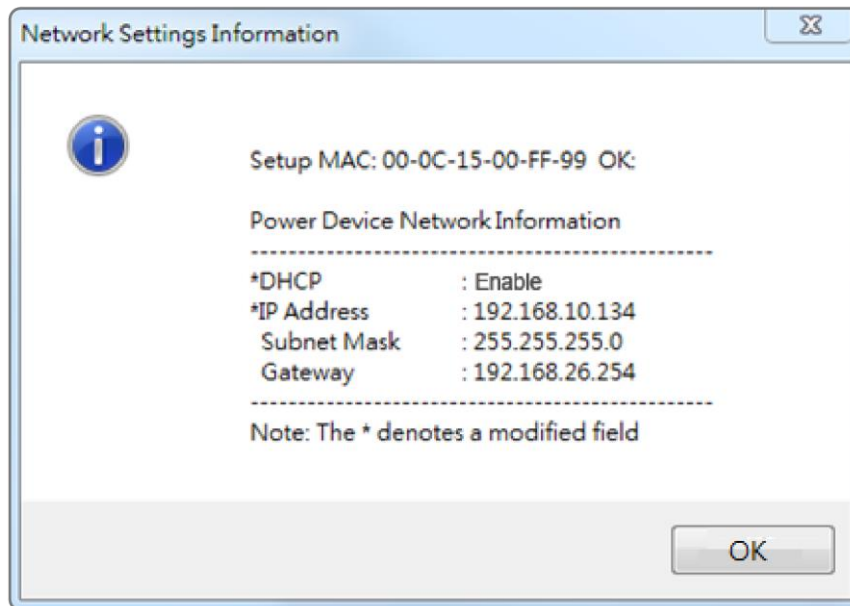

Figure 4. Setup IP Address successfully message.

9. In case the change is not successful, for example, if the IP address change is unsuccessful you will see a warning message. Attempt to make the desired changes again. If the problem persists please see the Troubleshooting section for help.

Method 2: Using a command prompt

1. Obtain the MAC address from the label on the Remote Management Card. Each Management Card has a unique MAC address.

Note: The MAC address is labelled on the card.

2. Use the ARP command to set the IP address.

Example:

To assign the IP Address 192.168.10.134 for the Remote Management Card, which has a MAC address of 00-0C-15-00-FF-99 you will type in the following in the command prompt from a PC connected to the same network as the Remote Management Card.

(1) Type in “arp -s 192.168.10.134 00-0C-15-00-FF-99” for Windows OS; type in “arp -s 192.168.10.134 00:0c:15:00:ff:99” for Mac OS, then press Enter.

3. Use the Ping command to assign a size of 123 bytes to the IP.

(1) Type in “ping 192.168.10.134 -l 123” then press Enter.

(2) If the replies are received, your computer can communicate with the IP address.

To select an available IP address for the Remote Management Card, please refer to Appendix 1.

Web Interface

Login User Account

You will need to enter a User Name and Password to login to the interface, and can select a preferred language after login. There are two user account types.

1. Administrator
 - Default user name: **cyber**
 - Default password: **cyber**
2. View only
 - Default username: **device**
 - Default password: **cyber**

You will be asked to reset a username and password upon the first login. The administrator can access all functions, including enable/disable the view only account. The viewer can access read only features but cannot change any settings.

Note: 1. The Administrator account is also used for the FTP login, Power Device Network Utility, and Upgrade and Configuration Utility.

2. Only one user can log in and access the device at a time.

Web Content

Note: English is the default language and you can change to a preferred language.

[Summary] Provide an overview of the system operation and the items that are auto refreshed; however, different UPS system models may have different items displayed.

Item	Definition
Current Condition	Display the current operating condition of the UPS and environmental sensor.
UPS Status	
Battery Capacity	Graph of the percentage of the current UPS battery capacity.
Load	Graph of the load of UPS as a percentage of available Watts.
Remaining Runtime	Length of time the UPS can support its load on battery power.
System Data	
Name	The name given to the UPS.
Location	Location description given to the UPS.
Contact	The person to contact about this UPS.
Uptime.	Length of time the system has been working continuously
Envir Status	
Temperature	Graph of the current temperature reading of the environmental sensor.
Humidity	Graph of the current humidity reading of the environmental sensor.

Item	Definition
Envir Data	
Name	The name of the environmental sensor.
Location	The location of the environmental sensor.
Recent Device Events	A list of the five most recent device events. All events are related to configuration changes.

[UPS] The following items can be displayed/configured through the UPS page; however, different UPS models may have different items displayed/configured.

[UPS->Status] Display the basic information about the current UPS status. Items displayed are auto refreshed.

Item	Definition
Input	
Status	The current status of the utility power supplied to the UPS.
Voltage	The current input voltage of the utility power supplied to the UPS.
Frequency	The current frequency of the utility power supplied to the UPS.
Output	
Status	The current status of the output power the UPS is supplying to connected equipment.
Voltage	The output voltage the UPS is supplying to the connected equipment.
Frequency	The output frequency the UPS is supplying to the connected equipment.
Load	The power draw of the connected equipment expressed as a percentage of the total UPS load capacity. This is displayed as watts in select UPS models.
Current	The output current the UPS is supplying to the connected equipment.
Non-Critical Load (NCL)	The present status of NCL outlets.
Energy	Device energy meter reading in units of kWh.
Battery	
Status	The present status of the UPS battery.
Remaining Capacity	The present capacity of the batteries, expressed as a percentage of full charge.

Item	Definition
Remaining Runtime	The amount of estimated time that the UPS can supply power to its load.
Voltage	The present voltage of the UPS battery.
System	
Status	The present operating status of the UPS.
Temperature	The operating temperature of the UPS.

[UPS->Battery Status] Display the information of the built-in battery and the Extended Battery Modules (EBM) including battery pack temperature, voltage of each battery within its pack and battery pack equalization status.

Item	Definition
Last Update Date	The last date that the battery status is updated. Update: Use this function to get the latest battery status.
Pack	The current number of UPS/EBM battery pack.
Temperature	The current temperature reading of UPS/EBM battery pack.
Voltage	The current voltage reading of each UPS/EBM battery.
Equalization Status	Display the current battery voltage equalization status of UPS/EBM battery pack. Active: The battery pack equalization function is active. Inactive: The battery pack equalization function is not active.

[UPS->Information] Display the technical specifications of the UPS.

Information	Description
Model	The model name of the UPS.
Serial Number	The serial number of the UPS.
Voltage Rating	The nominal output voltage rating (Volts) of the UPS.
Working Frequency	The operating frequency of the UPS output power.
Power Rating	The Volt-Amp rating of the UPS.
Current Rating	The output current rating (Amps) of the UPS.
Load Power	The power rating (Watts) of the UPS.
Battery Voltage Rating	The operating DC voltage rating of the battery power.
Firmware Version	The revision number of the UPS firmware. Update: Use this function to upgrade the UPS firmware. For further information, please refer to Appendix 3.
USB Version	The revision number of the UPS USB firmware
LCD Version	The revision number of the UPS LCD firmware

Information	Description
Battery Replacement Date	The date that the batteries were last replaced. This must be set manually after the batteries have been replaced or when the unit is first installed. If this date has not been set, it is recommended that it be set immediately.
NCL Bank	The amount of Non-Critical Load banks.
Extended Battery Modules	The amount of the external battery modules connected to the UPS. The number of modules is configured manually, and the configurations will vary by model.
Installation Place	When clicking the “Find it” button, either the alarm will beep or the indicators will flash on the UPS to alert users of the specific location. This helps users to identify a specific UPS in a multiple UPS installation.

[UPS->Configuration] Configure the parameters of the UPS.

Item	Definition
Supplied Power	
Voltage	Set the UPS output voltage that is supplied to the connected equipment.
Utility Power Failure Condition	
Utility Sensitivity	When the UPS detects the utility voltage is out of range, the UPS will switch to battery mode to protect the equipment plugged into the UPS. Low sensitivity has a looser voltage range and the supplied power may vary more widely. The power from fuel generator may cause the UPS to switch to battery mode more frequently, and the low sensitivity is recommended. The UPS switches to battery mode rarely and also saves more battery power. High sensitivity allows the UPS to supply more stable power to equipment and switches to battery mode frequently.
High/Low Input (or Output) Voltage Threshold	When the utility power voltage or output voltage (depending on UPS model) is higher/lower than the threshold, the UPS will supply battery power to the connected equipment.
Frequency Tolerance	Sets the acceptable range of the input frequency. The UPS will supply battery power to the connected equipment if it is out of tolerance.
Operation	
Normal	Normal operating mode of the UPS.

Item	Definition
Generator Mode	If the UPS uses generator as its input power, this option should enable the UPS to function normally. If this option is selected, the UPS will be forbidden to enter Bypass Mode or ECO Mode to protect the connected equipment.
ECO Mode	Economy mode. The UPS will enter Bypass Mode when the input voltage/frequency is within the configured threshold. Once the utility voltage/frequency exceeds thresholds, the UPS will switch to Normal operation. This mode will significantly increase UPS system efficiency.
Manual Bypass	Determines whether to allow the UPS to enter Manual Bypass Mode. If this option is enabled, the UPS will be forced to enter Bypass Mode.
Bypass	Note: The UPS may automatically enter Bypass Mode per these configured settings.
Bypass Condition	<p>No Bypass: If this option is selected, the UPS will not enter Bypass Mode and will stop supplying output power.</p> <p>Check Volt/Freq: If the utility voltage is in the range of the voltage thresholds and the utility frequency is in range of the frequency tolerance, the UPS will enter Bypass Mode. Otherwise the UPS will stop supplying output power.</p> <p>Check Volt Only: Only if the utility voltage is in the range of the voltage thresholds, the UPS will enter Bypass Mode. Otherwise the UPS will stop supplying output power.</p>
Bypass When UPS Off	When the UPS turn off, the UPS switch to Bypass Mode.
Power Restore	After utility power is restored, the UPS turns on automatically and supplies power to the connected equipment. The following settings are used to configure the UPS restore behavior:
Automatic Restore	When this option is enabled, the UPS will restore output immediately when the utility power restores. When this option is disabled, the UPS will not restore output until it is turned on manually at a later time.
Recharged Delay	When utility power restores, the UPS will start to recharge until the specified time has elapsed before restoring output power.
Recharged Capacity	When utility power restores, the UPS will start to recharge until the specified battery capacity is met before restoring output power.

Item	Definition
Returned Delay	The Returned Delay will take effect every time when the UPS is turned on.
Line Stable Delay	When the UPS is in Battery Mode and utility power is restored, the UPS will wait for the specific delay time to change Battery Mode to Line Mode. When the UPS battery is lower than the Low Battery Threshold and utility power is restored, the UPS will return to Line Mode immediately.
Battery	
Low Battery Threshold	When the UPS supplies battery power and the remaining capacity is lower than this threshold, the UPS will sound an alarm.
External Battery Modules	Set the amount of external battery modules. This allows for an accurate runtime estimation based upon the total number of batteries connected to the UPS.
Periodical Battery Test	<p>The UPS will cyclically perform the battery test automatically to ensure the batteries have full functional.</p> <p>Note: Only Online (OL) series support the Smart Battery Management (SBM) feature. SBM carries out battery tests, even if Periodical Battery Test setting is disabled.</p>
System	
Cold Start	Set the ability of the UPS to start in the absence of input power. When this option is enabled, the UPS can be turned on with battery power.
Audible Alarm	If this option is enabled, the UPS will issue an audible alarm when supplying battery power, when output is overloaded, or other conditions are present (varies by UPS model).
Dry Relay Function	<p>This configures the UPS dry relay to function when the selected condition occurs. Refer to the UPS manual for further information about advanced UPS dry relay functions. The Dry Relay Function can be configured to be activated under the following power conditions:</p> <ul style="list-style-type: none"> (1) Utility Failure: The utility power fails and the UPS is using battery power. (2) Low Battery: The battery capacity is too low to support the connected computers to shut down. (3) Alarm: The UPS is issuing the audible alarm due to the occurrence of warning events, such as overload. (4) Bypass: The UPS has switched to Bypass Mode. (5) UPS Fault: The UPS could be malfunctioning due to hardware

	fault.
Screen Save Time	When no UPS button is pressed and no power event occurs during this time, the LCD screen will go to sleep.
Wiring Fault Detecting	If this option is enabled, the UPS will detect if the input wiring is not grounded or is reversed. It is recommended to insure the UPS wiring has a ground connection first.
Over Discharge Protection	When the UPS is in Battery Mode with 0% for the time configured, the RMCARD will switch the UPS to Sleep Mode and the output will be turned off.
Enter Sleep Mode After All Clients Shutdown	If this option is enabled, the UPS will enter sleep mode after utility power fails and remaining MSDT+2 minutes. For more information about MSDT please reference the help page in UPS -> PowerPanel List.
Non-Critical Outlet Bank	
Turn Off Threshold	When supplying battery power, the UPS will power off this NCL outlet bank if the remaining battery capacity is lower than this threshold.
Turn off Delay	When supplying battery power, the UPS will power off this NCL outlet bank after this delay time is met.
Turn On Delay	When utility power is restored, the UPS will restore the output of this NCL outlet bank after the delay time is met. This prevents excessive power consumption caused by all the connected equipment starting at the same time.

[UPS->Master Switch] Switch the output power of the UPS to be on or off.

Item	Definition
Reboot UPS	Turns the UPS off and back on
Turn UPS Off	Turns the UPS off.
UPS Sleep	This command is available in Utility Power Failure Mode. It puts the UPS in sleep mode until power is restored. Note: Some UPS models may not support this command.
Reset	Resets the pending action to turn the UPS off.
Turn UPS On	Turns the UPS on.
Shutdown/Sleep Delay	Amount of time the UPS waits before it turns off in response to a "Reboot UPS", "Turn UPS off" or "UPS Sleep" command.
Reboot Duration	After the UPS is turned off, Reboot Duration defines how long the UPS waits before it turns back on response to "Reboot UPS" command.

Item	Definition
Signal PowerPanel® Clients to Shutdown	Select this option to warn PowerPanel® Business Edition Clients before turning the UPS off. The Shutdown Delay (MST, Max Clients Shutdown Time) for the UPS can be changed to insure a graceful shutdown.

[UPS->Bank Control] Display the current state of each outlet Bank, and it provides on/off control for the Non-Critical Outlet Bank. Outlet Number and Device Name displays the device name associated with the specific outlet.

Item	Definition
Bank Control Options	
ON	Turns non-critical bank on immediately.
OFF	Turns non-critical bank off immediately.
Device Name Identification	
Outlet #	UPS outlet number as designated by the outlet configuration (varies by UPS model).
Device Name	Device Name assigned to this outlet.

[UPS->Diagnostics] The **UPS/Diagnostics** page provides the ability to verify UPS batteries are in adequate working conditions. You can also complete a runtime calibration to insure an accurate estimation for the connected load.

Item	Definition
Battery Test	The Battery Test will force the UPS to switch to battery power for 10 seconds. This allows the user to verify the battery conditions and provides information about the battery, including the results and date of the last battery test. Click the “Start” button to begin a battery test. The information will be reported after a battery test completes. Note: “N/A” means the UPS model does not have this function.
Last Test Result	The results of the most recent battery test. Passed: The battery performed normally during the test. Failed: The battery test did not pass. Follow the steps below if the battery test fails: Repeat the battery test and replace the batteries if the test fails again. Contact CyberPower for assistance if the battery test fails after the batteries have been replaced.
Last Test Date	The date of the most recent battery test.

Item	Definition
Runtime Calibration	<p>The Runtime Calibration ensures the runtime estimate is accurate with the load and the current battery capacity. When a runtime calibration is initiated, the UPS will run on battery power until the batteries are completely discharged. The UPS will then automatically switch to input power. The batteries will start to recharge upon the completion of the calibration. Click the “Start” button to initiate a runtime calibration. Click the “Abort” button to stop the runtime calibration. The information will be reported after a calibration is finished or canceled.</p> <p>Note: 1. “N/A” means the UPS model does not have this function.</p> <p>2. It is recommended to perform at least one calibration every 3 months.</p> <p>3. A complete calibration causes the battery capacity to deplete. Ensure the UPS has sufficient time to completely recharge after performing a calibration.</p>
Estimated Runtime	The current estimated runtime of the batteries.
Last Elapsed Runtime	The amount of time of last Runtime calibration.
Last Calibration Result	<p>The results of the last Runtime calibration.</p> <p>Passed: The runtime calibration completed.</p> <p>Failed: The UPS could not complete a runtime calibration.</p> <p>Canceled: The calibration was interrupted.</p>
Last Calibration Date	The date of the last Runtime calibration.

[UPS->Schedule]: Sets the UPS to automatically shutdown and restart at scheduled times (Once/Daily/Weekly). The **Schedule** page manages scheduled shutdowns and lists all configured schedules. Each schedule row displays the details of when the schedule will take effect.

[Once]: The user may set one time event for the UPS to shutdown/restart.

[Daily]: Set a daily re-occurrence for the UPS to shutdown/restart.

[Weekly]: Set a weekly re-occurrence for the UPS to shutdown/restart.

1. Click [Once], [Daily] or [Weekly] option and Click “Next>>”, Enter the date and time to shut down the UPS. Select [Never], [Instant], or the date and time for the UPS to turn back on. Select the bank to be controlled, and click “Shutdown Clients” to set all clients to perform a graceful shutdown. You can enter a “Name” for this Schedule.
2. Click “Apply” to add the item to the Schedule. Click “Reset” to return to default settings..
3. Saved settings are listed in [Schedule] menu.

4. If you want to delete the scheduled action, simply click the Name of the item listed in [Schedule] menu, and click “Delete”.

Note: The management system allows up to 10 schedule entries.

[UPS->Wake on Lan] This function is used to wake a computer through the network. Enter the IP address of that computer when it is on and the system will search its MAC address accordingly. The maximum number of IP addresses that can be set is 50.

Item	Definition
PowerPanel Client	
Load/Sync with PowerPanel® Client List	Enable this option to Load and Synchronize WoL Client List with PowerPanel Client List.
Wake Conditions	
UPS Turn On	When selected, this option will enable the RMCARD to send the WoL signal to the connected PowerPanel Clients computers when the UPS turns on.
Utility Power Restore and Output is Supplied	When selected, this option will enable the RMCARD to send the WoL signal to the connected PowerPanel Clients computers when utility power is restored and UPS output is on.
WoL Client List	When the option “Load/Sync with PowerPanel® Client List” is enabled, it will list PPBE client PC IP/MAC here.
WoL Manual List	Wake on Lan manual list.

Note: The PowerPanel Client computer’s BIOS settings need to support WoL and be configured accordingly.

[UPS->EnergyWise] The EnergyWise initiative focuses on reducing the energy consumption of all devices connected to a Cisco network. Through this compatibility, the CyberPower Remote Management Card is recognized to work with other EnergyWise-enabled entities and can be easily monitored and controlled to achieve the best energy performance under the EnergyWise operation framework.

Item	Definition
Configuration	
Version	The version of EnergyWise supported.
EnergyWise	Enable CISCO EnergyWise support.
Service port	The port number used to communicate with EnergyWise devices (must be the same as that configured in the network switch).
Domain Name	The domain name of the EnergyWise solution (must be the same as that configured in the network switch).

Item	Definition
Off-State Cache	Enable/Disable the endpoint entries to be stored in the cache of the switch's EnergyWise list after a reboot.
Secure Mode	Enable EnergyWise use of a shared secret.
Shared Secret	The secret for the EnergyWise domain.
Node List	EnergyWise Parent/Children List shows all EnergyWise entities and allows users to configure EnergyWise Entity attributes.
Name	The name used to identify each outlet.
Role	This parameter is a string used to describe the function of the entity (max length 31 characters).
Keywords	This parameter is a string used to describe the entity (max length 31 characters).
importance	This parameter is a value between 1 and 100 that shows the entity's importance high to low.

[UPS->PowerPanel® List] Display the Information of the connected PPBE (PowerPanel® Business Edition) Clients. The connection is established by PPBE Clients. The listed clients will be removed if disconnected for 1 hour.

Item	Definition
Configuration	
Max Clients Shutdown Time (MST)	The max time that all the connected clients require to shutdown.
Max Clients Shutdown Delay Time (MSDT)	The max value required from the moment utility power fails until all the clients gracefully shutdown.

[Envir] Following items can be displayed/configured through the Envir page. Note that Envir Tab only appears when an ENVIROSENSOR is connected to the RMCARD.

[Envir->Status] Display the basic information of the environmental sensor and contact closure inputs.

Item	Definition
Information	
Name	The name of the environmental sensor.
Location	The location of the environmental sensor.
Temperature	
Current Value	The current environmental temperature.
Maximum	The highest temperature and time detected by the environmental sensor.

Item	Definition
Minimum	The lowest temperature and time detected by the environmental sensor.
Humidity	
Current Value	The current environmental humidity.
Maximum	The highest humidity and time detected by the environmental sensor.
Minimum	The lowest humidity and time detected by the environmental sensor.
Contact	Display the name and status (Normal/Abnormal) of each input dry relay contact.

[Envir->Configuration] Configure the parameters of the environmental sensor.

Item	Definition
Information	
Name	The name used to identify the environmental sensor.
Location	The place where the environmental sensor is located.
Temperature	
High Threshold	Upper limit for normal temperature.
Low Threshold	Lower limit for normal temperature.
Hysteresis	The point at which the difference between the High and Low temperature threshold changes from abnormal to normal.
Rate of Change	The rate used to define an abnormal change in temperature.
Unit	The unit of temperature measurement.
Humidity	
High Threshold	Upper limit for normal humidity.
Low Threshold	Lower limit for normal humidity.
Hysteresis	The point at which the difference between the High and Low humidity threshold changes from abnormal to normal.
Rate of Change	The rate used to define an abnormal change in humidity.
Contact	Enter the name of each input dry contact relay and use the dropdown menu to define the normal status of each one.

[Logs->Event Logs] Display the list of events and a brief description of each event along with the date and time stamp.

- Note:**
1. The recordable events are listed under “System->Notifications->Event Action.”
 2. The recorded time is using the 24-hour clock format.

[Logs->Status Records] This page is used to view the logs of the UPS status and environment status; however, different products may have different items displayed. All items have the same definition as they are in the UPS status or environmental status.

- Input min (V): The minimum input voltage of the utility power from the previous record.
- Input max (V): The maximum input voltage of the utility power from the previous record.
- Input (Hz): The current frequency of the utility power supplied to the UPS.
- Output (V): The output voltage of the UPS supplying to the connected equipment.
- Output (Hz): The output frequency of the UPS supplying to the connected equipment.
- Load (%): The percentage of the total UPS power being supplied to the connected equipment.
- Capacity (%): The percentage of the current UPS battery capacity.
- Remaining Runtime: The estimated duration of time that the UPS can support the connected load in battery mode.
- Temperature (°C or °F): The current temperature of the environmental sensor.
- Humidity (%RH): The current humidity of the environmental sensor.

[Logs->Energy Records] Energy Records page displays a list of energy records along with a date and time stamp.

Item	Definition
Energy	Energy used by the device during a specific interval, measured in kWh.
Cost	Cost of the energy used by the device during a specific interval.
CO2	CO2 emissions of the device during a specific interval.
Accumulated Energy	Cumulative energy used by the device since the last reset, measured in kWh.
Accumulated Cost	Cumulative cost of the energy used by the device since the last reset.
Accumulated CO2	Cumulative CO2 emissions from the device since the last reset.

[Logs->Graphing] This page is used to display the data of the Status Record. The graphing function makes the status records easier to view.

Item	Definition
Graph Period	The period used to draw the graph. Longer periods will require more time to be displayed.
Graph Data	The data used to draw the graph. The more data selected, the more graphing time is needed.
Graph Node	Selecting "Display All Nodes in Detail" will display all the points along the line; moving the cursor on the data point will show the information of that point.

Item	Definition
Launch Graph in New Window	Checking this box will open the graph in detail in a new page.

[Logs->Maintenance] This page is used to select “Event Logs” and “Status Records” settings. The application provides information on how many events are recorded before it is full.

Item	Definition
Event Logs	
Clear All Logs	Clear the existing event logs.
The Number of Events	The number of the existing event logs and the maximum number of the event logs that can be recorded. Once the maximum number is reached, new events overwrite oldest events in memory.
Save Event Logs	Save the existing event logs as a text file.
Status Records	
Recording Interval	Set the frequency status data is recorded. A smaller interval will provide more frequent recordings but exhaust available memory quicker. A larger interval will provide less frequent recordings, but save data for a longer period of time.
Clear All Records	Clear the existing status records.
Remaining Time	The time that records have been kept. A smaller recording interval leads to less remaining time while a larger recording interval leads to more remaining time. Once the maximum number is reached, new status records overwrite oldest status records in memory.
Save Status Records	Save the status records as a text file.

Note: Event Logs and Status Records use a First In First Out memory. Oldest data will be rewritten once memory is full.

[Logs->Syslog] Allow users to set syslog server and send test message.

Item	Definition
Syslog	Enable or disable Syslog function.
Facility Code	Select Syslog facility.
Server IP	The IP address of Syslog server.
Server Port	The UDP port used by the Syslog server.
Send Test	Send test message to Syslog server.

[System->General->Time] Display the system date and time and allow users to set it manually or by using the NTP (Network Time Protocol) server.

Item	Definition
Current Settings	Displays the current date and time on the card status and time until the next Network Time Protocol (NTP) update.
System Time Configuration	
Time Zone	Choose the RMCARD time zone in GMT(Greenwich Mean Time).
Using NTP server	Enter the IP address/domain name of NTP servers, and set the frequency to update the date and time from NTP server. Click "Update right now" to update immediately.
Manual Setup	Enter the date and time in the designated format.

[System->General->Identification] Assign the system's name, contact, and location.

Item	Definition
Name	The name of the equipment.
Location	Where the power equipment is located.
Contact	The person to contact about this equipment.

[System->General->Daylight Saving Time] Adjust the clock daylight saving time.

Item	Definition
DST Configuration	
Disable	Disable DST.
Tradition US DST	Set traditional US DST settings Start: 2:00, second Sunday in March. End: 2:00, first Sunday in November.
Manual DST	Manual DST date time rules.

[System->Security->Authentication] Set for login authentication and software authentication.

Item	Definition
Login Authentication	
Local Account	Use local account Administrator or Viewer settings to log in.
RADIUS , Local Account	Use RADIUS configuration settings to log in. If RADIUS authentication fails then Local Account settings will be used to log in.
RADIUS Only	Use RADIUS configuration settings to log in.

Item	Definition
LDAP , Local Account	Use LDAP configuration settings to log in. If LDAP authentication fails then Local Account settings will be used to log in.
LDAP Only	Use LDAP configuration settings to log in.
Software Authentication	
Secret Phrase	The Authentication Phrase used to communicate with PowerPanel Business Edition Client. Note: For more information, please refer to Appendix 4.

[System->Security->Local Account] This page is used to configure the login account.

Information	Description
Administrator	Administrator has full access to read/write configuration settings.
Viewer	Viewer has restricted access to read only.
Admin/Viewer Manager IP	This setting determines what IP address is allowed to access the device using either Admin or Viewer accounts. If you want to access RMCARD from any IP address, you can set one of them as 0.0.0.0 or 255.255.255.255. Note: A range of IP addresses can be allowed by entering the subnet mask. For example 192.168.20.0/16 means the IP which has subnet of 192.168.0.0 can be allowed to access.

Change Administrator account:

1. Enter User Name
2. Enter Current Password
3. Set the Manager IP (*optional*)
4. Enter New Password
5. Enter Confirm Password
6. Click "Apply"

Change Viewer account:

1. Select "Allow Access" to enable the Viewer account
2. Enter the User Name
3. Set the Manager IP (*optional*)
4. Enter New Password
5. Enter Confirm Password
6. Click "Apply"

Note: The maximum length of both User Name and Password is 15 characters.

[System->Security->RADIUS Configuration] After setting the proper RADIUS server, the Remote Management Card can use user name and password set on the RADIUS server to login.

Item	Definition
Server IP	The IP address of RADIUS server.
Shared Secret	The shared secret of RADIUS server.
Server Port	The UDP port used by the RADIUS server.
Test Setting	Test RADIUS server using user name and password settings. If authentication is successful the settings will be saved.
Skip Test	Save RADIUS server settings without testing.

Note: Please refer to Appendix 2 for the account configuration in RADIUS servers.

[System->Security->LDAP Configuration] After setting the proper LDAP server, the Remote Management Card can use user name and password that set on the LDAP server to login.

Item	Definition
LDAP Server	The IP address of LDAP server.
LDAP SSL	Enable to communicate with LDAP server by LDAPS.
Port	The TCP port used by the LDAP(S) server.
Base DN	The Base DN of LDAP server.
Login Attribute	The Login Attribute of LDAP user entry (for example: cn or uid).
Generic LDAP Server	Select LDAP server type as OPENLDAP.
Active Directory	Select LDAP server type as Windows AD.
AD Domain	The AD Domain of the Active Directory server.
Test Setting	Test LDAP(S) server using user name and password settings. If authentication is successful the settings will be saved.
Skip Test	Save LDAP(S) server settings without testing.

Note: Please refer to Appendix 2 for the account configuration in LDAP & Windows AD servers.

[System->Security->Session Control] Set for timeout setting for open sessions to automatically log off.

Item	Definition
Timeout	The period (in minutes) that the system waits before automatically logging off.

[System->Network Service->TCP/IPv4] Display the current TCP/IPv4 settings. Set DHCP and DNS server settings.

Item	Definition
Current Configuration	Displays the current TCP/IP settings: IP address, subnet mask, gateway, and DNS server.
DHCP	Select the “Enable DHCP” option and click “Apply” to get IP address, Subnet Mask, and Gateway from DHCP server. Select the “Obtain DNS Address from DHCP” and click “Apply” to get the IP of DNS from the DHCP server.
Manual	Enter the TCP/IP settings directly and click “Apply”.

[System->Network Service->TCP/IPv6] Display and configure the current IPv6 settings.

Item	Definition
IPv6 Interface	Displays the current IPv6 address.
IPv6 Gateway	Displays the current IPv6 gateway.
IPv6 Configuration	
Access	Set the IPv6 service to either Enable or Disable.
Address Mode	
Router Control	The IPv6 address is assigned through one of the following methods as configured in the router settings: Stateless Address Auto-configuration, Stateless DHCPv6 or Stateful DHCPv6.
Manual	The IPv6 address is assigned manually.
Manual IPv6 Address	Enter the IPv6 address directly when the Manual setting is selected.

[System->Network Service->SNMPv1 Service] Allow users to use a NMS and configure the appropriate SNMPv1 settings.

Item	Definition
SNMPv1 Service	
Allow Access	Set the SNMP service to either Enable or Disable.
SNMPv1 Access Control	
Community	The name used to access this community from a Network Management System (NMS). The field must be 1 to 15 characters in length.

Item	Definition
IP Address	<p>NMS access can be restricted by entering a specific IP address or an IP network subnet mask. The following subnet mask rules apply:</p> <ul style="list-style-type: none"> • 192.168.20.255: Access only by an NMS on the 192.168.20 segment. • 192.255.255.255: Access only by an NMS on the 192 segment. • 0.0.0.0 (the default setting) or 255.255.255.255: Access by any NMS on any segment.
Access Type	<p>The allowable action for the NMS through the community and IP address.</p> <ul style="list-style-type: none"> • Read Only: GET command allowed any time; SET command restricted. • Write/Read: GET command allowed any time; SET command allowed anytime unless a user session is active. • Forbidden: GET and SET commands are restricted.

[System->Network Service->SNMPv3 Service] Allow users to use a NMS and configure the appropriate SNMPv3 settings.

Item	Definition
SNMPv3 Service	
Allow Access	Set the SNMPv3 service to either Enable or Disable.
SNMPv3 Access Control	
User Name	The name to identify SNMPv3 user. The field must be 1 to 31 characters in length.
Authentication Password	The password used to generate the key used for authentication. The field must be 16 to 31 characters in length.
Privacy Password	The password used to generate the key used for encryption. The field must be 16 to 31 characters in length.
IP Address	<p>NMS access can be restricted by entering a specific IP address or an IP network subnet mask. The following subnet mask rules apply:</p> <ul style="list-style-type: none"> • 192.168.20.255: Access only by an NMS on the 192.168.20 segment. • 192.255.255.255: Access only by an NMS on the 192 segment. • 0.0.0.0 (the default setting) or 255.255.255.255: Access by any NMS on any segment.
Authentication Type	The hash type for authentication.
Privacy Type	The type of data encryption/decryption.

Note: The privacy protocol cannot be selected if no authentication protocol is selected.

[System->Network Service->Web Service] Select Enable to allow access to the HTTP or HTTPS Service and configures the TCP/IP port for them.

Item	Definition
Access	
Allow Access	<p>Enable the access to HTTP or HTTPS service. The HTTPS supports encryption algorithm list as follow:</p> <ul style="list-style-type: none"> • AES (256/128 bits) • Camellia (256/128 bits) • 3DES (168 bits) • DES (168 bits) • RC4 SHA (128 bits) • RC4 MD5 (128 bits)
Http Settings	
Http Port	The TCP/IP port of the Hypertext Transfer Protocol (HTTP) (80 by default)
Https Settings	
Https Port	The TCP/IP port of the Hypertext Transfer Protocol Secure (HTTPS) (443 by default)
Certificate Status	<ul style="list-style-type: none"> • Valid Certificate (or Invalid Certificate): Click to view Certificate detailed information. • Upload Certificate: Click to upload a certificate and replace the current one. <p>Note: The format of uploading certificate must in a standard PEM (Privacy Enhanced Mail).</p>

[System->Network Service->Console Service] Select Enable to allow access to the Telnet or SSH Service and configures the TCP/IP port that Telnet or SSH uses to communicate.

Item	Definition
Access	
Allow Access	Enable the access to Telnet or SSH version 2, which encrypts transmission of user names, passwords and data.
Telnet Settings	
Telnet Port	The TCP/IP port (23 by default) that Telnet uses to communicate.

Item	Definition
SSH Settings	
SSH Port	The TCP/IP port (22 by default) that SSH uses to communicate.
Hostkey Status	<p>Display the status of hostkey fingerprint to show whether it is valid or invalid.</p> <ul style="list-style-type: none"> • Upload Hostkey: Click to upload a Hostkey and replace the current one. • Export Hostkey: Click to export a current Hostkey.
Hostkey Fingerprint	The hostkey fingerprint uploaded by users will be displayed in this field.

Note: To enhance security, users can change port setting to any unused port from 5000 to 65535. Users must then specify the non-default port to obtain access. Telnet clients require users to append either a space and the port number or a colon and the port number to the command line to access the control console.

[System->Network Service->FTP Service] Allow users to Enable/Disable the FTP server service and configure the TCP/IP port of the FTP server (21 by default).

Item	Definition
Allow Access	Enable the access to FTP server.
Service Port	The TCP/IP port of the FTP server (21 by default). Users can change port setting to any unused port from 5000 to 65535 to enhance security.

Note: The FTP server is used for upgrading Firmware. For more details about the upgrade process, please refer to “Firmware Upgrade” section.

[System->Notifications->Event Action] Configure notification settings for every Device Event. Events are categorized for ease of management.

- Log: Record the event in the “Event Logs”.
- E-mail: Send an email to a specific user (An available SMTP server is necessary).
- Trap: A SNMP trap sent to a specific IP address.
- SMS: Send a short message to a specific mobile phone number (An available SMS service provider is needed).

[System->Notifications->SMTP Server] After setting the proper SMTP server, event notification email can be sent to recipients when specific events occur.

Item	Definition
Service Provider	The service provider of e-mail account. There are two options: General and Gmail.
General	Select General as service provider. Complete all field settings and click Apply to save.

Item	Definition
Gmail	Select Gmail as the service provider. Click Authorize for an authorization to send a mail notification. Then complete the sender name and click Apply to save the settings.
SMTP server address	The IP address or Host Name of the SMTP server used to send email notifications.
Sender's E-mail Address	Email address used to send the email notification.
Authentication	Select this option if the SMTP server requires to authenticate the user.
Username	Username used for Authentication.
Password	Password used for Authentication.
Secure connection	Enable TLS or SSL security.
Service port	The port number used to communicate with the SMTP server.

[System->Notifications->E-mail Recipients] Set up to five email recipients to receive notifications when configured Events occur.

To add a new recipient, click “New Recipient”. To modify or delete an existing Recipient, click the e-mail address of that recipient. To check if SMTP setting and the email recipients are set correctly, click “TEST” button to send a test message.

[System->Notifications->Trap Receivers] Setup up to 10 SNMP TRAP receivers by IP address (IPv6 supported). SNMPv1 and v3 is supported. The listed TRAP receivers will be notified when device Events occur.

To add a new receiver, click “New Receiver”. To modify or delete an existing receiver, click the IP address or name of that receiver. To check if the traps can be received correctly, click “TEST” button.

[System->Notifications->SMS Service] Short Message Service (SMS) is a communication service used by mobile communication systems. Using standardized communication protocols will allow the interchange of short text messages between mobile devices. The system provides 4 methods for users to choose how they want to send the messages.

Item	Description
Service provider is Clickatell	<p>Select the Clickatell option in the SMS Method field. Complete all the account details including Username, Password and HTTP API ID fields.</p> <p>For example:</p> <p>User Name Name</p> <p>Password Passwd</p> <p>HTTP API ID 3234599</p>
Service provider accepts HTTP GET	<p>This specification from the SMS provider is required before using the HTTP GET method. Select the Using HTTP GET option in the SMS Method field. Insert the E_PHONE_NUMBER as recipient's mobile phone number and the E_PHONE_MESSAGE as event message, described by the SMS provider specification, and fill in the URL field. The expressions will be replaced by relevant content before the message is sent by the SMS provider.</p> <p>For example:</p> <p>URL</p> <p>http://ServiceProviderURL?user=Name&password=Passwd&api_id=3234599&to=E_PHONE_NUMBER&text=E_MESSAGE</p>
Service provider accepts HTTP POST	<p>This specification from the SMS provider is required before using the HTTP POST method to deliver messages via SMS providers. Select the Using HTTP POST option in the SMS Method field. Insert E_PHONE_NUMBER as recipient's mobile phone number and E_PHONE_MESSAGE as the event message, described by the SMS provider specification, and fill in the POST URL and POST BODY fields. The expressions will be replaced by the relevant content before the message is sent by the SMS provider.</p> <p>For example:</p> <p>URL http://ServiceProviderURL</p> <p>Content</p> <p>user=Name&password=Passwd&api_id=3234599&to=E_PHONE_NUMBER&text=E_MESSAGE</p>

Item	Definition
Service provider accepts E-mail (SMTP)	<p>This specification from a SMS provider is required before using the E-mail to deliver the messages via SMS providers. Select the Using E-mail option in the Service Provider field. Insert E_PHONE_NUMBER as recipient's mobile phone number and the E_PHONE_MESSAGE as event message, described by the SMS provider specification. Fill in the Recipient's Address, Subject and Content. The expressions will be replaced by the relevant content before the message is sent by the SMS provider.</p> <p>For example:</p> <p>Address sample@cyberpower.com</p> <p>Subject TestSubject</p> <p>Content E_PHONE_NUMBER&text=E_MESSAGE</p>

[System->Notifications->SMS Recipients] Users can set up to 10 mobile phone numbers as SMS recipients. The Recipients will receive a short message notification when configured events occur.

To add a new recipient, click "New Recipient". To modify or delete an existing Recipient, click the mobile number or Name of that recipient. To test SMS settings, click "TEST" button and see if the test message is correctly received.

[System->Reset/Reboot] Reset or reboot the RMCARD system.

Item	Definition
Reboot System	Restart the system without turning off and restarting the UPS.
Reset System	Reset the system to factory default setting. The system will restart. This action will not turn off or restart the UPS.
Reset System (TCP/IP Settings Reserved)	Reset the system to factory default setting but reserving TCP/IP. The system will restart This action will not turn off or restart the UPS.

[System->About] Display system information for the Remote Management Card.

Item	Definition
Model Name	Model name of the Remote Management Card.
Hardware Version	The hardware version of the Remote Management Card.
Firmware Version	The current firmware version installed on the Remote Management Card.
Firmware Updated Date	The last date the firmware was updated.
Serial Number	Serial number of the Remote Management Card.
MAC Address	MAC address of the Remote Management Card.
Save Configuration	Click “Save” to save the RMCARD configuration file. The text file name will have a default format of YYYY_MM_DD_HHMM.txt.
Restore Configuration	Use this function to restore a configuration that had been previously saved. Click “Choose File” to select the location of the saved configuration file and click “Submit”.

Command Line Interface

How to log on

Users can log on to the command line interface through either console network access (Telnet or SSH) or local access (Serial port).

1. Network access to the command line interface

When user logs in with the admin username and admin password through Telnet or SSH, there are two types of interfaces available. One is the command line interface (CLI) and the second is a menu interface. The default is CLI. If the user wants to change to the menu interface, type in the [menumode] command. To switch back to CLI, it is necessary to logout and login to the RMCARD.

How to use telnet access command line interface

Step 1: Need to make sure the computer has access to the RMCARD installed network. At a command prompt, type telnet and the IP address for the RMCARD (for example, telnet 139.225.6.133, when the RMCARD uses the default Telnet port of 23), and press Enter.

Step 2: Enter the user name and password (by default, user name: cyber, password: cyber)

How to use SSH access command line interface

SSH is highly recommended for using to access the command line interface. SSH encrypts user names, passwords, and transmitted data. To use SSH you must first configure SSH and install an SSH client program (eg. PuTTY, HyperTerminal, or Tera Term) on your computer.

Note: If using PuTTY to configure SSH access, please configure Line discipline of Terminal to “Force off”, as shown in Figure 5.

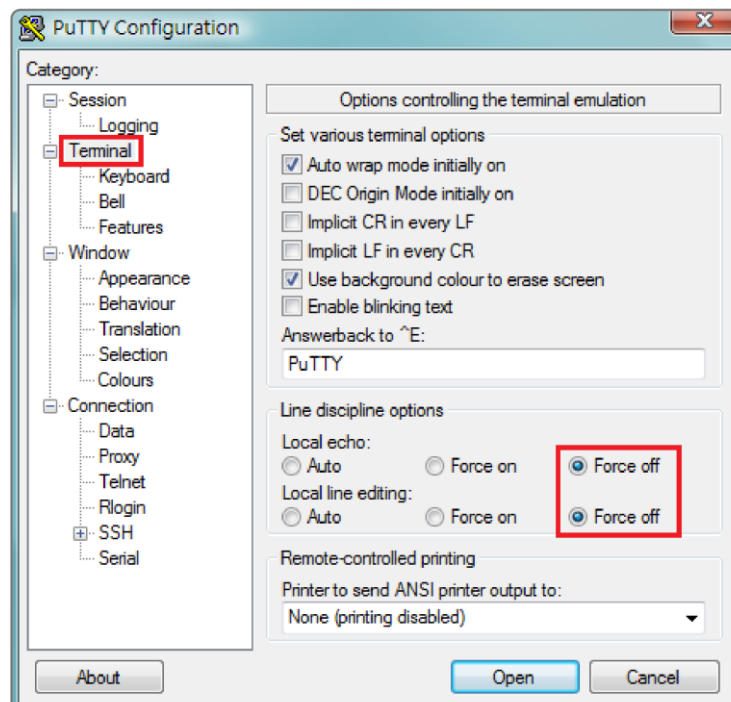

Figure 5. The PuTTY Configuration window.

2. Local access to the command line interface

To log on via serial connection, the PC/server must be connected directly to the Universal port of the RMCARD using the included RJ45/DB9 Serial Port Connection Cable, and perform the following steps.

Step 1. Open Hyper Terminal software (eg. PuTTY, HyperTerminal, or Tera Term) on your PC and select a name and icon for the connection.

Step 2. Setup the COM port settings using the following values

*Bits per second: 9600

*Data bits: 8

*Parity: None

*Stop bits: 1

*Flow control: None

Step 3. Press Enter to enter the Authentication menu.

Step 4. Enter the user name and password of the RMCARD at the Authentication menu.

Note: Serial connection can only access Command Line Mode and cannot support Menu Mode.

How to use the Command Line Interface

While using the command line interface, you can also do the following:

1. To close the connection to the command line interface → Type “exit” and press Enter
2. To switch mode as Menu Mode → Type “menumode” and press Enter
3. To view a list of available commands or arguments → Type “?” (Eg. date ?).
4. To view the command that was typed most recently in the session → Press the UP/DOWN arrow key. (The session can remember up to ten previous commands.)
5. A command can support multiple options → To define the date as March 21, 2015 (Eg. date yyyy 2015 mm 3 dd 21)

Command Response Codes

When the command or arguments is not recognized or is incorrect, the console interface will display [^] underneath the wrong command or argument. The following error message will be displayed:

Command not found	RMCARD doesn't know this command. Console interface display the list of available commands.
Parameter Error	The parameter type or format is not allowed. Console interface display the list of available value or format.

Command Descriptions

ups

Description: Show the information about UPS, input, output. And use master switch to control UPS.

Option	Argument	Description
info	show	Display UPS information
input	show	Display UPS input information
output	show	Display UPS output information

Example 1:

To view UPS information

```
CyberPower > ups info show
```

```
UPS information
```

```
Model: OL1000XL
```

```
Voltage Rating: 100V
```

```
Working Frequency: 40~70 Hz
```

```
Power Rating: 1000 VA
```

```
Current Rating: 10 Amp
```

```
Load Power: 900 Watts
```

```
Battery Voltage Rating: 36 V
```

```
USB Version: 0.1B
```

```
Next Battery Replacement Date: 10/08/2018
```

```
NCL Bank: 1
```

```
Extended Battery Pack: 4
```

upsctrl

Description: Enable to use UPS Master Switch.

Option	Argument	Description
reboot	off delay / reboot duration (eg. 10/10) off delay: 0 10 20 30 60 120 180 300 600 reboot duration: 10 20 30 60 120 180 300 600	Turns the UPS off and back on. There is one string include off delay (in seconds) and reboot duration (in seconds), ex: 10/10 means off delay in 10 seconds and reboot duration in 10 seconds.
on		Turns the UPS on.
off	0 10 20 30 60 120 180 300 600	Turns the UPS off. Argument means Turn Off Delay in seconds.

Option	Argument	Description
sleep	0 10 20 30 60 120 180 300 600	This command is available in Utility Power Failure Mode. It can make UPS in sleep mode until power restore. The argument means Sleep Delay in seconds.

Example 1:

To reboot UPS turn off delay 10sec and reboot duration 20sec.

CyberPower > **upsctrl reboot 10/20**

upscfg

Description: Show and configure UPS supply power, UPS sensitivity, UPS high voltage threshold, UPS low voltage threshold, UPS bypass condition, UPS bypass high threshold, UPS bypass low threshold, UPS recharge delay, UPS recharge capacity, UPS working mode, and UPS return delay.

Option	Argument	Description
show		
outpwr	<output power in VAC>	Sets the output voltage which is supplied to the connected equipment.
sen	high medium low	Low sensitivity has a looser voltage range and the supplied power may vary more widely. The power from fuel generator may cause the UPS to switch to battery mode more frequently, and the low sensitivity is recommended. The UPS switches to battery mode rarely and also saves more battery power. High sensitivity allows the UPS to supply the more stable power to equipment and switches to battery mode frequently.
hvlimit	<high threshold in VAC>	When the utility voltage (or output voltage) exceeds the threshold, the UPS will supply battery power to the connected equipment.
lvlimit	<low threshold in VAC>	When the utility voltage (or output voltage) exceeds the threshold, the UPS will supply battery power to the connected equipment.

Option	Argument	Description
bypasscond	nobypass freqvolt voltonly	<p>No Bypass – If this option is selected, the UPS will not enter Bypass mode and will stop supplying output power.</p> <p>Check Volt/Freq – If the utility voltage is in the range of the <i>High/Low Bypass Voltage</i> and the utility frequency is in the range of the <i>Frequency Tolerance</i>, the UPS will enter Bypass mode. Otherwise the UPS will stop supplying output power.</p> <p>Check Volt Only – Only if the utility voltage is in the range of the <i>High/Low Bypass Voltage</i>, the UPS will enter Bypass mode. Otherwise the UPS will stop supplying output power.</p>
bypasshvlimit	10 15	Set high bypass voltage in percentage. If the utility voltage exceeds thresholds, the UPS will be forbidden to enter Bypass mode.
bypasslvlimit	10 15 20	Set low bypass voltage in percentage. If the utility voltage exceeds thresholds, the UPS will be forbidden to enter Bypass mode.
rechargedelay	0 60 120 180 300 600 1200 1800 3600	Set the recharge delay in seconds. When the utility power restores, the UPS will start to recharge until the specified delay is expired before restoring output power.
rechargecap	0 15 30 45 60 75 90	Set the recharge capacity in percentage. When the utility power restores, the UPS will start to recharge until the specified battery capacity is met before restoring output power.

Option	Argument	Description
workmode	normal eco10% eco15% generator bypass	<p>normal—Normal working mode of the UPS.</p> <p>eco10%—On-line UPS enters Economy 10% mode.</p> <p>eco15%—On-line UPS enters Economy 15% mode.</p> <p>generator—If the UPS uses generator as its input power, this option should enable the UPS to function normally. If this option is selected, the UPS will be forbidden to enter Bypass mode to protect the powered equipment.</p> <p>bypass—Determines whether to allow the UPS to enter Manual Bypass mode. If this option is enabled, the UPS will be forced to enter Bypass mode.</p>
returndelay	0 ~ 600	When the utility power restores, the UPS will start to recharge until the specified delay is expired before restoring output power. The numbers in the range 1 to 600 seconds are numbers divisible by 5.

Example 1:

To view the available value voltage this UPS output power can be set.

```
CyberPower > upscfg supply?
```

```
100
```

```
110
```

```
115
```

Example 2:

To define bypass condition as check utility voltage only

```
CyberPower > upscfg bypasscond voltonly
```

Example 3:

To define UPS recharge delay as 2 minutes

```
CyberPower > upscfg rechargedelay 120
```

Example 4:

To set On-line UPS mode to generator mode

```
CyberPower > upscfg mode generator
```

upsbatt

Description: Show information of battery, and execute the battery test and battery runtime calibration.

Option	Argument	Description
show		Display all battery information for this UPS
test		Execute the battery test immediately.
cal	start stop	Start or stop Runtime calibration.
rdyyyy	<number of year>	Set year of battery replacement date by AD.
rdmm	<number of month>	Set month of battery replacement date.
rddd	<number of date>	Set day of month.

Example 1:

To execute battery selftest.

CyberPower > **upsbatt test**

Example 2:

To start battery runtime calibration

CyberPower > **upsbatt cal start**

Example 3:

To set the battery replacement date as May 29, 2018.

CyberPower > **upsbatt rdyyyy 2018 rdmm 5 rddd 29**

date

Description: Show and configure timezone, date format, date, time.

Option	Argument	Description
show		Display system date information for RMCARD
timezone	<time zone offset>	Choose the RMCARD time zone in GMT (Greenwich Mean Time).
format	mm/dd/yyyy yyyy/mm/dd dd.mm.yyyy mmm-dd-yy dd-mmm-yy yyyy-mm-dd	Set system date format
yyyy	<number of year>	Set year of system date by AD.
mm	<number of month>	Set month of system date.
dd	<number of date>	Set day of month.
time	<00:00:00>	Set system time.

Example 1:

To define timezone offset as +08:00

CyberPower > **date timezone +0800**

Example 2:

To define the date as March 21, 2015

CyberPower > **date yyyy 2015 mm 3 dd 21**

Example 3:

To define the time as 13:45:12

CyberPower > **date time 13:45:12**

ntp

Description: Show and configure NTP server IP, NTP update interval time.

Option	Argument	Description
show		Display all NTP information for RMCARD
access	enable disable	If enable was set, System will set date and time from NTP server.
priip	<primary ntp server ip>	Set the IP address/domain name of primary NTP servers
secip	<secondary ntp server ip>	Set the IP address/domain name of secondary NTP servers
update	now 1-8760	now – Choose <i>Update right now</i> to update immediately. 1-8760 – Set the frequency to update the date and time from NTP server.

Example 1:

To enable NTP server define date and time of RMCARD

CyberPower > **ntp access enable**

Example 2:

To setup primary NTP server IP as “192.168.26.22”

CyberPower > **ntp priip 192.168.26.22**

Example 3:

To update time by NTP immediately

CyberPower > **ntp update now**

sys

Description: Show and configure identification of RMCARD, reset RMCARD.

Option	Argument	Description
show		Display all system information for RMCARD
name	<system name>	Set name of the equipment.
location	<system location>	Set the location of power equipment.
contact	<system contact>	Set the person to contact about this equipment.
reset	reboot notcpip all	Reboot – Reboot RMCARD notcpip – Reset the System to default setting but reserving TCP/IP settings, and restart it. all – Set all to reset the System to default setting and restart it.

Example 1:

To view all information of system

```
CyberPower > sys show
```

```

Name: RMCARD305 (205)
Location: Server Room
Contact: Administrator
Model: RMCARD305 (205)
Hardware Version: 1.1
Firmware Version: 1.0.3
Firmware Update Date: 03/08/2015
Serial Number: TALGY2001975
MAC Address: 00-0C-15-00-B9-42

```

Example 2:

To reset RMCARD to default parameter.

```
CyberPower > sys reset all
```

dst

Description: Show and configure type of Daylight Saving Time.

Option	Argument	Description
show		Display all DST information for RMCARD
mode	disable us manual	<p>disable— Disable DST. us— Tradition US DST manual— Manual DST date time rules. After finish this command, input start and end time step by step.</p> <p>The parameters of Week of month: first second third forth last</p> <p>The Parameters of day of week: Mon Tue Wed Thu Fri Sat Sun</p> <p>The parameters of month: Jan Feb Mar Apr May Jun Jul Aug Sep Oct Nov Dec</p>

Example 1:

Manual set Daylight Saving Time

CyberPower > **dst type manual**

Start time (0~23): **2**

Start week of month: **second**

Start day of week: **Sun**

Start month: **Mar**

End time (0~23): **2**

End week of month: **first**

End day of week: **Sun**

End month: **Nov**

Example 2:

To view DST setting

CyberPower > **dst show**

DST: Manual DST Date Time

Start: 02:00, the second Sunday of Mar

End: 02:00, the first Sunday of Nov

login

Description: Show and configure authentication for login.

Option	Argument	Description
show		Display all login information for RMCARD
type	local radiuslocal radiusonly ldaplocal ldaponly	<p>local—User to login Remote Management Card with user name and password that configured in Local Account.</p> <p>radiuslocal—User to login Remote Management Card with user name and password for authenticate with RADIUS server first. If the RADIUS server fails to respond, the user name and password that configured in Local Account will be used.</p> <p>radiusonly—User to login Remote Management Card with user name and password for authenticate with RADIUS server only.</p> <p>ldaplocal—User to login Remote Management Card with user name and password for authenticate with LDAP server first. If the LDAP server fails to respond, the user name and password that configured in Local Account will be used.</p> <p>ldaponly—User to login Remote Management Card with user name and password for authenticate with LDAP server only.</p>
secretphrase	<Authentication Phrase>	The Authentication Phrase used to communicate with PowerPanel Business Edition Client
timeout	1~10	The period (in minutes) that the system waits before auto logging off. The range of argument is from 1 to 10 (in minutes).

Example 1:

To change authentication type to Radius, Local Account
 CyberPower > **login type radiuslocal**

admin / device

Description: Show and configure the primary/secondary manager IP, username, password of admin/device user.

Option	Argument	Description
show		Display all admin or device information for this RMCARD
primip	<primary manager IP>	Set primary manager IP of admin/device
secmipac	enable disable	Enable or disable secondary manager IP of admin/device
smip	<secondary manager IP>	Set secondary manager IP of admin/device
name	<user name>	Set user name of admin/device
passwd	<user password>	Set user password of admin/device

Example 1:

To define primary admin manager IP as 192.168.26.0/24

CyberPower > **admin pmip 192.168.26.0/24**

Input admin password : **cyber**

Pass

radius

Description: Show and configure information of radius server.

Option	Argument	Description
show		Display all Radius server information for RMCARD
add		Add radius server then input radius server IP/Secret/Port appear later on.
priip secip	<radius server IP>	Set the IP address of primary/secondary RADIUS server.
priport secpport	<radius server port>	Set the UDP port which is used by the primary/secondary Radius server
prisecret secsecret	<radius server secret>	Set the shared secret of primary/secondary Radius server.
pridel secdel		Delete primary/secondary Radius server

Example 1:

To add radius server

CyberPower > **radius add**

Radius Server IP: 192.168.26.33

Radius Server Secret: testsecret

Radius Server Port: 1812

Example 2:

To view radius server information

```
CyberPower > radius show
```

Primary Radius Server

Server IP: 192.168.26.33

Server Secret: testsecret

Server Port: 1812

ldap

Description: Show and configure information of LDAP server.

Option	Argument	Description
show		Display all LDAP server information for RMCARD
add		Add LDAP server then input information for requirements appear later on.
pritype sectype	openldap ad	Set the type of LDAP server.
priip secip	<LDAP server IP>	Set the IP address of primary/secondary LDAP server.
prissl secssl	enable disable	Enable or disable using LDAPS.
priport secpport	<LDAP server port>	Set the TCP port which is used by the primary/secondary LDAP server.
pridn secdn	< LDAP server base DN>	Set the Base DN of primary/secondary LDAP server.
priaddomain secaddomain	< LDAP server AD domain>	Set the AD Domain of the primary/secondary Active Directory server.
priattr secattr	< LDAP server login attribute>	Set the Login Attribute of primary/secondary LDAP user entry.
pridel secdel		Delete primary/secondary LDAP server.

Example 1:

To add LDAP Server

```
CyberPower > ldap add
```

Input LDAP Server Type [openldap | ad]: **ad**

Input IP address: **192.168.26.33**

Use SSL [enable | disable]: **disable**

Input LDAP port: **389**
 Input base DN: **dc=cyber,dc=com**
 Input login attribute: **cn**
 Input AD Domain: **cyber.com**

Example 2:

To view information about LDAP Server

CyberPower > **ldap show**

Primary LDAP Server

Type: **Windows AD**
 LDAP Server: **192.168.26.33**
 LDAP SSL: **Disable**
 Port: **389**
 Base DN: **dc=cyber,dc=com**
 Login Attribute: **cn**
 AD Domain: **cyber.com**

tcpip

Description: Show and configure IPv4 IP, netmask, gateway, DNS.

Option	Argument	Description
show		Display all IPv4 information for RMCARD
dhcp	enable disable	Enable or disable DHCP
dns	manual auto	Auto – Obtain DNS Address from DHCP when DHCP enable Manual – Obtain DNS Address by manual when DHCP enable.
ip	<system IP>	Set IP Address of system
netmask	<system netmask>	Set netmask of system
gateway	<system gateway>	Set gateway of system
dnsip	<system dns>	Set DNS of system

Example 1:

To disable DHCP and define IP address to 192.168.26.33

CyberPower > **tcpip dhcp disable ip 192.168.26.33**

tcpip6

Description: Show and configure status of IPv6 router control, IPv6 manual IP.

Option	Argument	Description
show		Display all IPv6 information for RMCARD
access	enable disable	Enable or disable IPv6 service.
routerctrl	enable disable	The IPv6 address is assigned through the method (Stateless Address Autoconfiguration, Stateless DHCPv6 or Stateful DHCPv6) which is decided by router setting.
manual	enable disable	Enable or disable IPv6 manual ip.
ip	<manual IPv6 IP>	Set manual IPv6 ip.

Example 1:

To define IPv6 manual IP address then show the information of IPv6

```
CyberPower > tcpip6 manualip 2001:cdba:0:0:0:0:3257:9652 show
```

```
Access: Enable
```

```
Router Control: Enable
```

```
Manual: Enable
```

```
Manual IPv6 Address: [2001:cdba::3257:9652]
```

snmpv1

Description: Show and configure status of SNMPv1.

Option	Argument	Description
show		Display SNMPv1 status for RMCARD
access	enable disable	Enable or disable SNMPv1.

snmpv3

Description: Show and configure status of SNMPv3.

Option	Argument	Description
show		Display SNMPv3 status for RMCARD
access	enable disable	Enable or disable SNMPv3

web

Description: Show and configure web access type, http port and https port.

Option	Argument	Description
show		Display all web information for RMCARD
access	http https disable	http – Enable the access to http service. https – Enable the access to https service. disable – Disable web service
httpport	<http port>	The TCP/IP port of the Hypertext Transfer Protocol (HTTP) (80 by default)
httpsport	<https port>	The TCP/IP port of the Hypertext Transfer Protocol Secure (HTTPS) (443 by default)

Example 1:

To change the HTTP server port to 5000
CyberPower > **web httpport 5000**

console

Description: Show and configure console network access type, telnet port and SSH port.

Option	Argument	Description
show		Display all console information for RMCARD
access	telnet ssh disable	telnet – Enable the access to Telnet ssh – Enable the access to SSH disable – Disable console service
telnetport	<telnet port>	The TCP/IP port (23 by default) that Telnet uses to communicate.
sshport	<ssh port>	The TCP/IP port (22 by default) that SSH uses to communicate.

Example 1:

To set SSH server port to 5000 and enable the access to SSH
CyberPower > **console sshport 5000 access ssh**

ftp

Description: Show and configure FTP access type and TCP/IP port of FTP.

Option	Argument	Description
show		Display all FTP information for RMCARD
access	enable disable	Enable or disable FTP server
port	<ftp port>	The TCP/IP port of the FTP server (21 by default).

Example 1:

To enable FTP service

CyberPower > **ftp access enable**

eventlog

Description: View and clear the eventlog of RMCARD and UPS.

Option	Argument	Description
show		Displays the list of events and a brief description of each event along with the date and time stamp.
clear		Clear the existing event logs.

Example 1:

CyberPower > **eventlog show**

12/11/2015 03:32:08 Admin login from 192.168.26.33.

.....

Then use the following keys to navigate the event log.

Key	Description
SPACE	View the next page of event log.
Q	Close the event log and return to command line interface.

Example 2:

To clear all event logs.

CyberPower > **eventlog clear**

Do you want to clear all eventlog [yes / no]: **yes**

syslog

Description: Show and configure information of SYSLOG server.

Option	Argument	Description
show		Display all syslog information for RMCARD
add		Add syslog server then input syslog server IP /Port appear later on.
access	enable disable	Enable or disable syslog.
facility	kernel user mail system auth1 syslog link news uucp clock1 auth2 ftp ntp logaudit logalert clock2 local0 local1 local2 local3 local4 local5 local6 local7	Set Syslog facility.

Option	Argument	Description
s1ip s2ip s3ip s4ip	<SYSLOG server IP>	Set the IP address of Syslog server for 1 to 4 servers.
s1port s2port s3port s4port	<SYSLOG server port>	Set the UDP port which is used by the Syslog server 1 to 4 servers.
s1test s2test s3test s4test		Send test message to Syslog server for 1 to 4 servers.
s1del s2del s3del s4del		Delete Syslog server for 1 to 4 servers.

Example 1:

To add Syslog server.

```
CyberPower > syslog add
Syslog Server IP: 192.168.26.33
Syslog Server Port: 514
```

Example 2:

To view information of syslog

```
CyberPower > syslog show
Syslog: Enable
Facility Code: user
Server1
    IP: 192.168.26.33
    Port: 514
```

menumode

Description: Switch mode as Menu Mode.

exit

Description: Close the connection to the command line interface.

clear

Description: Clear the console screen.

Reset to Factory Default Setting / Recover from a Lost Password

To reset the CyberPower Remote Management Card to its factory default setting (including web log-in user name and password), please following these steps:

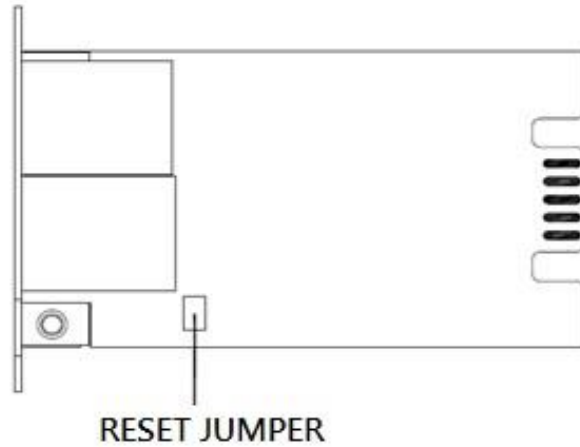

RMCARD205

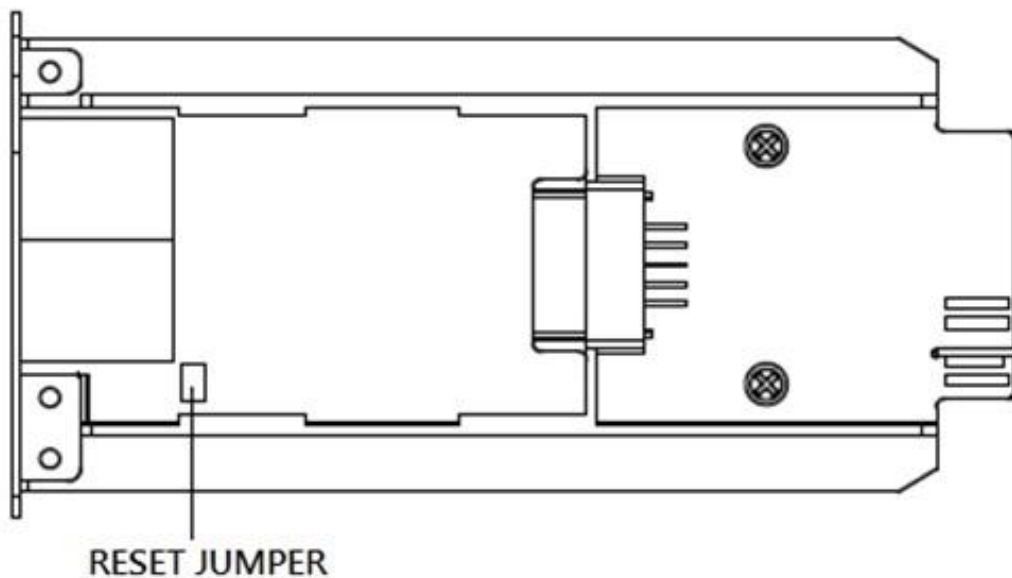

RMCARD305

1. Remove the card from the UPS without turning the UPS/ATS PDU off.
2. Remove the jumper from the reset pins as illustrated. Do not dispose of the jumper.
3. Insert the card into the expansion port on the UPS/ATS PDU.
4. Wait until the green Tx/Rx LED is flashing (the frequency of the ON/OFF flashing is once per second).
5. Remove the card again.
6. Place the jumper back onto the Reset pins.
7. Install card into the expansion port again and tighten the retaining screws.

RMCARD Firmware Upgrade

By upgrading the firmware, you can obtain both the new features and updates/improvements to existing functionality. FTP service needs to be Enabled before attempting to execute a Firmware Upgrade. You can check the “Firmware version” on the **[System->About]** page on the web user interface of the RMCARD. There are two files to update in order to upgrade the firmware version.

- A. cpsrm2scfw_XXX.bin
- B. cpsrm2scdata_XXX.bin

Note: To ensure keeping RMCARD firmware up to date, please visit CyberPower website every 3 months to see if there is any updated firmware version available.

Note: Please do not turn the UPS off when processing the Firmware upgrade.

Note: To update the RMCARD firmware successfully, please check whether the connections to Port 20 and 21 in firewall are not blocked.

Method 1: Using FTP command

Use the following steps to upgrade the firmware:

1. Download the latest firmware
2. Extract the downloaded files to “C:\”
3. Open a command prompt window
4. Login to the CyberPower Remote Management Card with FTP command, in the command prompt type:
 - (1) ftp
 - (2) ftp> open
 - (3) To [current IP address of RMCARD] [port]; EX: To 192.168.22.126 21
 - (4) Input USER NAME and PASSWORD (same as the administrator account in web user interface, see page 6 for default factory settings)
5. Upload file A, type:

```
ftp > bin
ftp > put cpsrm2scfw_XXX.bin
```
6. Upload is now complete, type:

```
ftp > quit
```
7. The system will reboot after you type “quit”
8. Login to the FTP again as step 4
9. Upload file B, type:

```
ftp > bin
ftp > put cpsrm2scdata_XXX.bin
```
10. Upload is now complete, type:

```
ftp > quit
```
11. The system will reboot after you type “quit”

Method 2: Using Upgrade and Configuration Utility (Bulk firmware upgrade tool)

1. Install the CyberPower Upgrade and Configuration Utility tool available for download at www.CyberPower.com.
2. After installation completes, run the “Upgrade and Configuration Utility”.
3. The main window of the Upgrade and Configuration Utility tool program is shown in Figure 6. The configuration tool will display all CyberPower Remote Management devices present on the local network subnet. The “Discover” button is used to search the local network subnet again.

Note: You can click “View” to select the items you want to view.

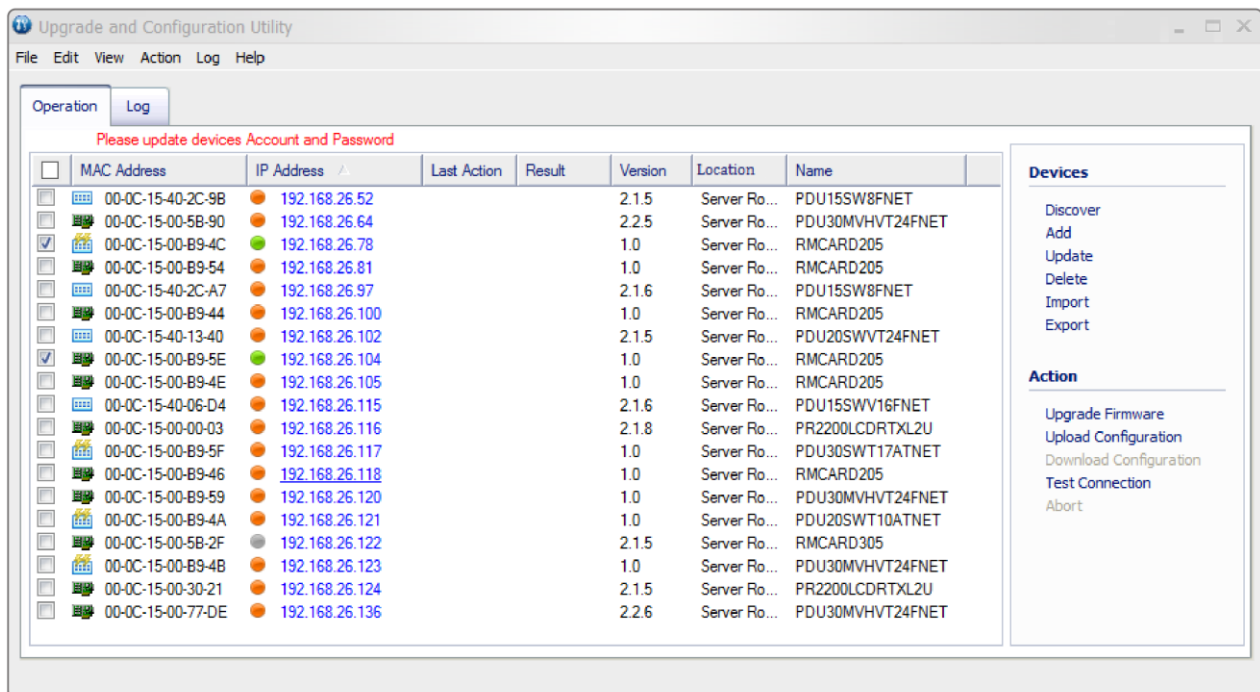

Figure 6. The main window of the “Upgrade and Configuration Utility” program.

4. Check the boxes to select the devices you wish to upgrade, and select “Update” on the right to update the device user account and password. Once the update is confirmed the status icon next to the IP Address will change from orange to green.

Note: You must update the device user account and password credentials before firmware upgrade.

5. Select the devices you wish to upgrade by checking their respective checkbox and select “Upgrade Firmware”.

Note: You can upgrade the firmware of multiple devices that use the same firmware files (Bulk firmware upgrade).

6. Select the Firmware and Data files and click “OK” to implement firmware upgrade, as shown in Figure 7.

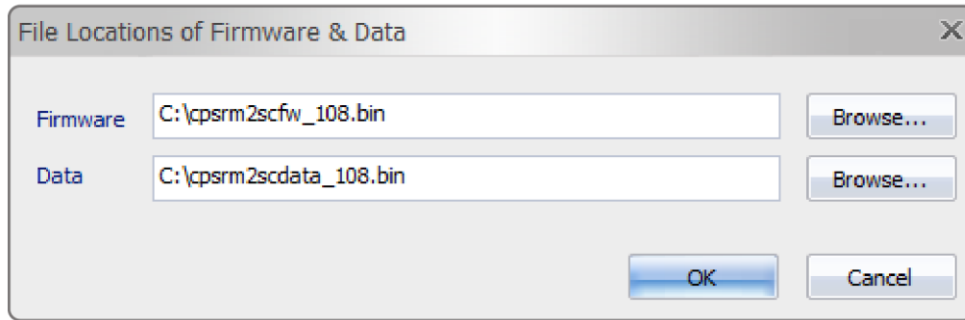

Figure 7. The File Locations of Firmware & Data window.

7. Click “Yes” to start firmware upgrade on selected devices, as shown in Figure 8.

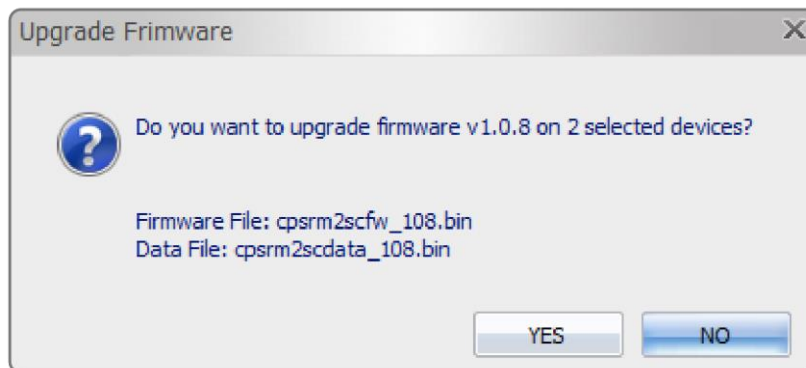

Figure 8. Confirm Upgrade Firmware message window

8. If the firmware upgrade is implemented, you will see the Result in the main window, as shown in Figure 9.

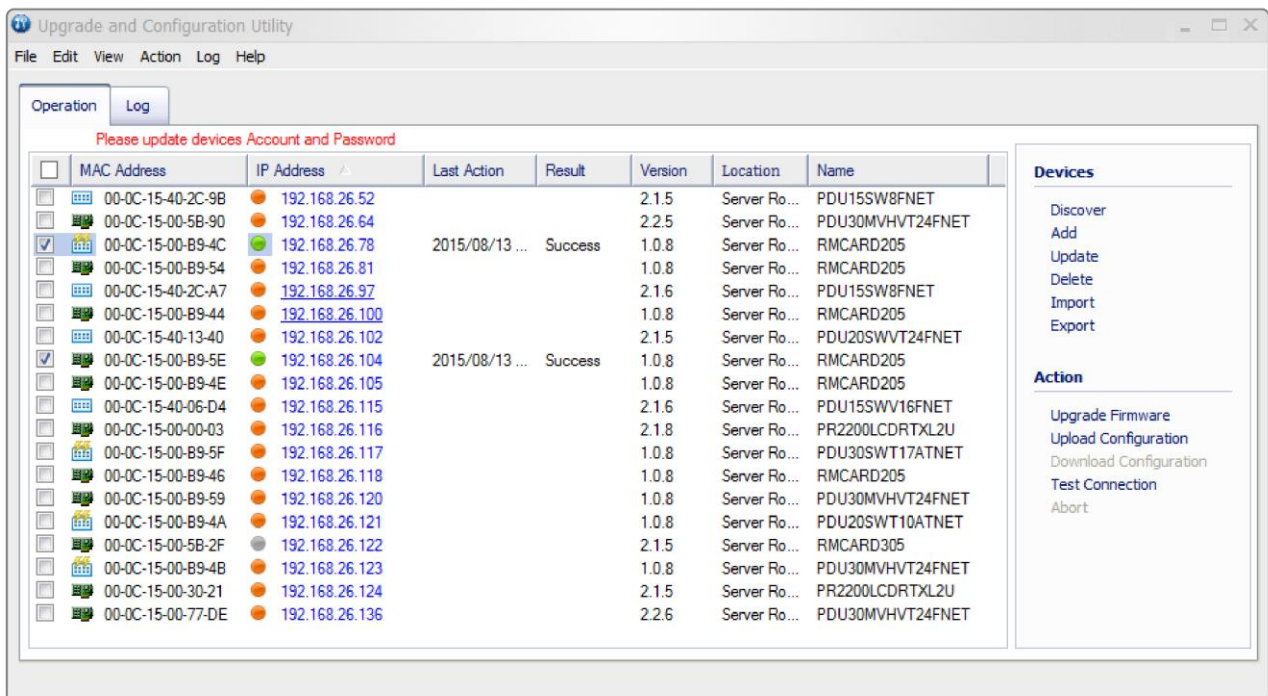

Figure 9. Firmware upgrade success in the main window.

Method 3: Using Secure Copy (SCP) command

Use the following steps to update firmware via SCP.

Note: Only firmware version 1.12 and above supports the functionality to update firmware via SCP.

For Windows Users:

1. Download any PuTTY Secure Copy client (PSCP) utility.
2. Save the firmware files and the PSCP Utility in the same folder.
3. Open the Command Line Interface and change the path to where the firmware files and the PSCP Utility are saved.
4. Enter the following command to perform the firmware update:

```
pscp -scp <filename> <user>@<IP address of RMCARD>:
```

Note:

- (1) The SSH setting on the RMCARD must be Enabled.
- (2) <filename> is the filename of the firmware file. There are two firmware files to upload: `cpsrm2scfw_XXX.bin` and `cpsrm2scdata_XXX.bin`. In order to upgrade the firmware version both files need to be uploaded. Only one firmware file can be uploaded at a time, it is recommended to upload the firmware file `cpsrm2scfw_XXX.bin` first followed by the data file `cpsrm2scdata_XXX.bin`.
- (3) <user> is the username of the SSH account on the RMCARD.
- (4) Ensure to add “:” after the IP address.

For example:

```
pscp -scp cpsrm2scfw_xxx.bin cyber@192.168.1.100:
```

Note: `cpsrm2scfw_xxx.bin` is the firmware file of the version being updated.

5. After executing the command, a message may appear asking if you trust the host. To continue type “y” for yes within 10 seconds.
6. On the next screen enter the RMCARD password. The firmware file transfer may take a couple minutes to complete. Please wait until the progress indicator displays 100%. The system will automatically log out and reboot after the transfer is complete.
7. Repeat steps 4 through step 6 to upload the data file `cpsrm2scdata_XXX.bin` to complete the firmware update process.
8. If the firmware file transfer is unsuccessful you will see an error message. Attempt to retype the command and execute it again.

For Linux, MacOS and Unix Users:

1. Install the related distribution of an SSH or SCP client, for example Openssh client.
2. Open the Terminal and change the path to where the firmware files are saved.
3. Enter the following Command to perform firmware update:

```
scp <filename> <user>@< IP address of RMCARD>:
```

Note:

- (1) The SSH setting on the RMCARD must be Enabled.
- (2) <filename> is the filename of the firmware file. There are two firmware files to upload: `cpsrm2scfw_XXX.bin` and `cpsrm2scdata_XXX.bin`. In order to upgrade the firmware version both files need to be uploaded. Only one firmware file can be uploaded at a time, it is recommended to upload the firmware file `cpsrm2scfw_XXX.bin` first followed by the data file `cpsrm2scdata_XXX.bin`.
- (3) <user> is the username of the SSH account on the RMCARD.
- (4) Ensure to add “:” after the IP address.

For example:

```
scp cpsrm2scfw_xxx.bin cyber@192.168.1.100:
```

Note: `cpsrm2scfw_xxx.bin` is the firmware file of the version being updated.

4. After executing the command, a message may appear asking if you trust the host. To continue type “y” for yes within 10 seconds.
5. On the next screen enter the RMCARD password. The firmware file transfer may take a couple minutes to complete. Please wait until the progress indicator displays 100%. The system will automatically log out and reboot after the transfer is complete.
6. Repeat steps 3 through step 5 to upload the data file `cpsrm2scdata_XXX.bin` to complete the firmware update process.
7. If the firmware file transfer is unsuccessful you will see an error message. Attempt to retype the command and execute it again.

Save and Restore Configuration Settings

The screenshot shows the 'UPS Remote Management' web interface. The top navigation bar includes the title 'UPS Remote Management', user information 'Administrator login from 192.168.26.63', a 'Logout' link, a flag icon, and the 'CyberPower' logo. A secondary navigation bar contains links for 'Summary', 'UPS', 'Log', 'System' (which is highlighted), and 'Help'. On the left, a sidebar menu lists 'General', 'Security', 'Network Service', 'Notification', 'Reset/Reboot', and 'About' (which is highlighted). The main content area is titled 'About' and contains an 'Information' table with the following data:

Model	RMCARD205
Hardware Version	1.0
Firmware Version	1.0
Firmware Update Date	08/04/2015
MAC Address	00-0C-15-00-B9-42

Below the table is the 'Save/Restore Configuration' section, which is highlighted with a red box. It contains the following elements:

- 'Save Configuration' with a 'Save' button.
- 'Restore Configuration' with a text input field and a 'Browse...' button.
- A 'Submit' button.

Figure 10. Save/Restore Configuration in the main window.

You can easily save and restore the device configuration to your local PC on the **[System->About]**, as shown in Figure 10.

To save the configuration file, click "Save" to save the configuration to your local PC. The text file will have a default format of YYYY_MM_DD_HHMM.txt. To restore a configuration, click "Browse" to the location of the saved configuration file and click "Submit" to restore a configuration that has been saved earlier.

Troubleshooting

Problem	Solution
Unable to configure the Remote Management Card using method 1 or method 2	<ol style="list-style-type: none"> 1. Check the LED status, it is normal when the yellow and green LEDs are both on. If green LED is off : ▶Check if the Remote Management Card is properly seated in the device and the device has power. If yellow LED is off : ▶Ensure the network connection is good. 2. Ensure the PC being used is on the same local network subnet as the CyberPower device you are trying to communicate with. 3. Ensure the Jumper on the Reset Pin is correctly installed.
Unable to ping the Remote Management Card	<ol style="list-style-type: none"> 1. Use method 1 and/or method 2 to get/set a correct IP address for the Remote Management Card. 2. If the PC being used is on a different network subnet from the Remote Management Card, verify the setting of subnet mask and the IP address of gateway.
Lost the user name and password	Please refer to the “Reset to Factory Default Setting / Recover from a Lost Password” section.
Default Network Setting	IP: 192.168.20.177 Subnet mask: 255.255.255.0 DHCP: On
Unable to access the Web Interface	<ol style="list-style-type: none"> 1. Ensure you can ping the RMCARD. 2. Ensure you are specifying the correct URL. 3. Ensure the HTTP/HTTPS access is enabled by logging in to the card via CLI (Telnet or SSH client).
Unable to operate a SNMP get/set	SNMPv1: Verify the community name. SNMPv3: Verify the user profile configuration.
Unable to receive traps	<ol style="list-style-type: none"> 1. Ensure the trap types (SNMPv1/SNMPv3) and trap receiver are configured correctly. 2. Ensure the IP address of gateway is configured correctly if the RMCARD and NMS are on a different network.

Conformance Approvals

FCC Warning

This equipment has been tested and found to comply with the limits for a Class A Digital Device, pursuant to Part 15 of the FCC Rules. These limits are designed to provide reasonable protection against harmful interference in residential installation. This equipment generates, uses and can radiate radio frequency energy and, if not installed and used in accordance with the instructions, may cause harmful interference to radio communications. Operation of this equipment in a residential area is likely to cause harmful interference in which case the user will be required to correct the interference at his own expense.

Any special accessories needed for compliance must be specified in the instruction.

This device complies with part 15 of the FCC Rules. Operation is subject to the following two conditions: (1) This device may not cause harmful interference, and (2) this device must accept any interference received, including interference that may cause undesired operation.

The Class A digital apparatus meets all requirements of the Canadian Interference-Causing Equipment Regulation.

Cet appareil numérique de la class A respecte toutes les exigences du Règlement sur le matériel brouilleur du Canada.

European Union

This is a class A product. In a domestic environment this product may cause radio interference in which case the user may be required to take adequate measures.

Appendix 1: IP Address Identification for CyberPower Remote Management Card

Overview

All devices on a computer network need to have an IP address. Each device's IP address is unique. The same address cannot be used twice. In order to assign an IP address to the CyberPower Remote Management Card, you must determine the range of the available IP addresses, and then choose an unused IP address to assign to the Remote Management Card.

Note: You may need to contact your network administrator to obtain an available IP address.

Procedures to find an IP address:

1. Locate the subnet of the CyberPower Remote Management Card.

One way to determine the range of possible IP addresses is to view the network configuration on a workstation. Click on [Start] and select [Run]. Type "command" into the open box and click [OK]. At the command prompt type "ipconfig /all" and press [Enter]. The computer will display network information as listed below:

```
Ethernet adapter
Connection-specific DNS Suffix.....: xxxx.com
Description.....: D-Link DE220 ISA PnP LAN adapter
Physical Address.....: 00-80-C8-DA-7A-C0
DHCP Enabled.....: Yes
Autoconfiguration Enabled...: Yes
IP Address.....: 192.168.20.102
Subnet Mask.....: 255.255.255.0
Default Gateway.....: 192.168.20.1
DHCP Server.....: 192.168.20.1
DNS Servers.....: 211.20.71.202
                  168.95.1.1
```

2. Select an IP Address for the CyberPower Remote Management Card

Verify the IP Addresses for the computer and the Remote Management Card belong to the same subnet. Refer to the above network information, the possible IP Address for the Remote Management Card could be 192.168.20.* (* hereafter represents any number between 1 and 255). Similarly, if the Subnet Mask is 255.255.0.0, the IP Address for Remote Management Card could be set up as 192.168.*.* to reach the same subnet with the computer. To verify there is no other equipment connected to the network using the same IP Address, run “Ping 192.168.20.240” at the DOS Mode prompt when the IP Address you would like to set is 192.168.20.240. If the response is presented as below, the IP address is most likely not used and may be available for the CyberPower Remote Management Card.

```
Pinging 192.168.20.240 with 32 bytes of data:
```

```
Request timed out.  
Request timed out.  
Request timed out.  
Request timed out.
```

If the response is shown as below, the IP address is in use. Try another IP address until an available address is found.

```
Pinging 192.168.20.240 with 32 bytes of data:
```

```
Reply from 192.168.20.240: bytes=32 time<10ms TTL=64  
Reply from 192.168.20.240: bytes=32 time<10ms TTL=64  
Reply from 192.168.20.240: bytes=32 time<10ms TTL=64  
Reply from 192.168.20.240: bytes=32 time<10ms TTL=64
```

Appendix 2: How to Configure a RMCARD User Account in Authentication Servers

RADIUS

1. Add a new attribute to RADIUS Dictionary as the Cyber vendor:

3808 - Vendor

2. Add two new specific attributes to RADIUS server interface under the vendor:

(1)**Cyber-Service-Type** (integer variable)

Cyber-Service-Type can accept three integer parameter values:

1 - Administrator

2 - Viewer

3 - Outlet User

(2)**Cyber-Outlets** (string variable)

Cyber-Outlets can accept a string describing outlet numbers. This attribute will let the outlet user access and control the designated outlets. For example, Cyber-Outlets="1,2,5" allows the user to control outlets 1, 2 and 5.

The example of the Dictionary File:

```
VENDOR      Cyber      3808
BEGIN-VENDOR Cyber
ATTRIBUTE   Cyber-Service-Type  1      integer
ATTRIBUTE   Cyber-Outlet        2      string
VALUE       Cyber-Service-Type  Admin   1
VALUE       Cyber-Service-Type  Viewer  2
VALUE       Cyber-Service-Type  Outlet  3
END-VENDOR  Cyber
```

LDAP & Windows AD

Add one of the attributes below to **description** on the OpenLDAP or Windows AD interface for indicating the user account type and authentication:

1. **cyber_admin** (Administrator)

2. **cyber_viewer** (Viewer)

3. **cyber_outlet="string"** (Outlet user)

The string entered in cyber_outlet designates what outlets the Outlet User can access and control. For example, cyber_outlet="1,2,5" allows the user to control outlets 1, 2 and 5.

Appendix 3: UPS Firmware Upgrade

You can check the “Firmware version” on the [UPS->Information] page on the web user interface of the RMCARD.

Method 1: Using Web Interface

1. Turn off the UPS via the [UPS->Master Switch].
2. Go to Firmware Version page via the [UPS->Information->Firmware Version].
3. Upload the UPS firmware by clicking Update then Choose File to select the location of the UPS firmware file.
4. Click Submit to implement the update, and an upgrade success window will show up after upgrade has completed.
5. Turn on the UPS via [UPS->Master Switch].

Method 2: Using FTP Command

FTP service needs to be Enabled before attempting to execute a Firmware Upgrade. Use the following steps to upgrade the firmware via FTP:

1. Turn off the UPS.
2. Extract the update file to “C:\”
3. Open a command prompt window
4. Login to the CyberPower Remote Management Card with FTP command, in the command prompt type:
 - (1) ftp
 - (2) ftp > open
 - (3) To [current IP address of RMCARD] [port]; EX: To 192.168.22.126 21
 - (4) Input USER NAME and PASSWORD (same as the administrator account in web user interface, see page 6 for default factory settings)
5. Upload the file, type:

```
ftp > bin
ftp > put XXX.bin
```
6. Upload is now complete, type:

```
ftp > quit
```
7. Turn on the UPS.

Note: 1. It may take about 5 mins to complete the update. Please do not carry out any other actions or pull out the RMCARD during the UPS firmware update process.

Note: 2. The update progress can only display in web interface.

Note: 3. If you see a message “Uploaded an invalid UPS firmware” after uploading the UPS Firmware file via Web interface, please check:

- (1) The file is Binary file for UPS firmware.
- (2) The UPS firmware file is supporting the UPS Model.

Appendix 4: Software Support

PowerPanel® Business Edition Client is used to perform a graceful operating system shutdown when protected by a UPS/ATS PDU with a remote management card installed. PowerPanel® Business Edition software is available on CyberPower Systems official website. Please visit www.CyberPower.com and go to the software section for free download.

Communicate with PowerPanel® Business Edition Client

The remote management card requires to authenticate with PowerPanel Business Edition Client via a shared secret phrase, as shown in Figure 11.

Note: The default secret phrase is 'powerpanel.encryption.key'.

Figure 11. RMCARD System>Authentication web UI.



Note: PowerPanel® Business Edition software supports automated graceful shutdown of VMware ESX/ESXi hosts as well as other virtualization platforms such as Microsoft Hyper-V and Citrix.

Obtain IP Address for Linux Operating System

The instructions in 'Configure the IP address for the CyberPower Remote Management Card' section are for Windows OS. For Linux Operating System, please use PowerPanel® Business Edition Client software to scan and obtain the IP address. To do this, go to **[Power->Configuration]** on the PowerPanel® Business Edition Client web interface, as shown in Figure 12. For more information, please refer to PowerPanel® Business Edition User's Manual.

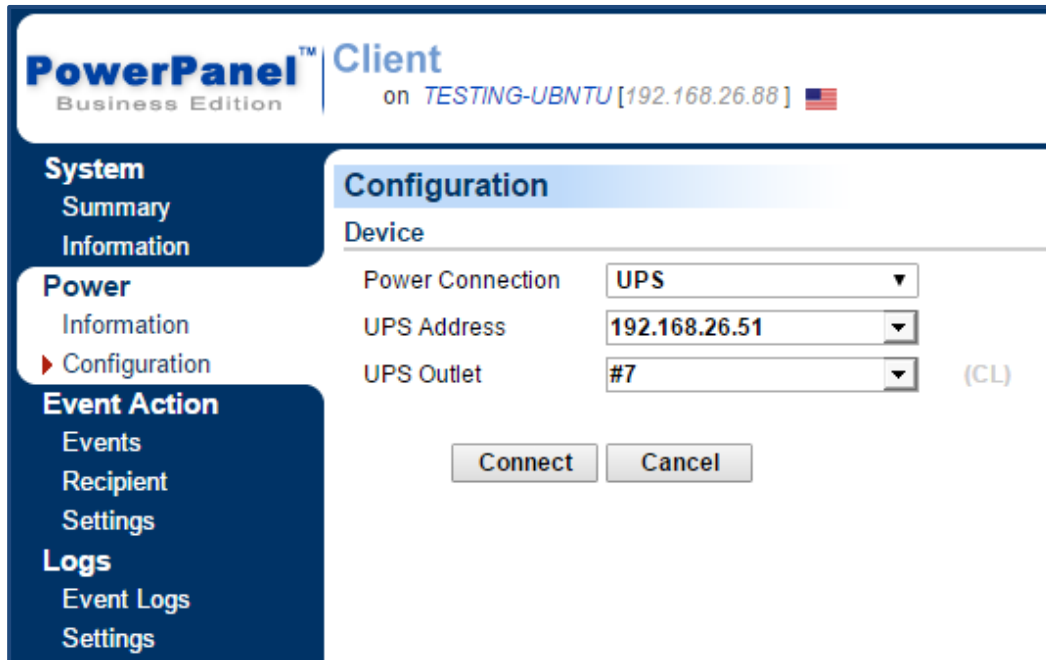
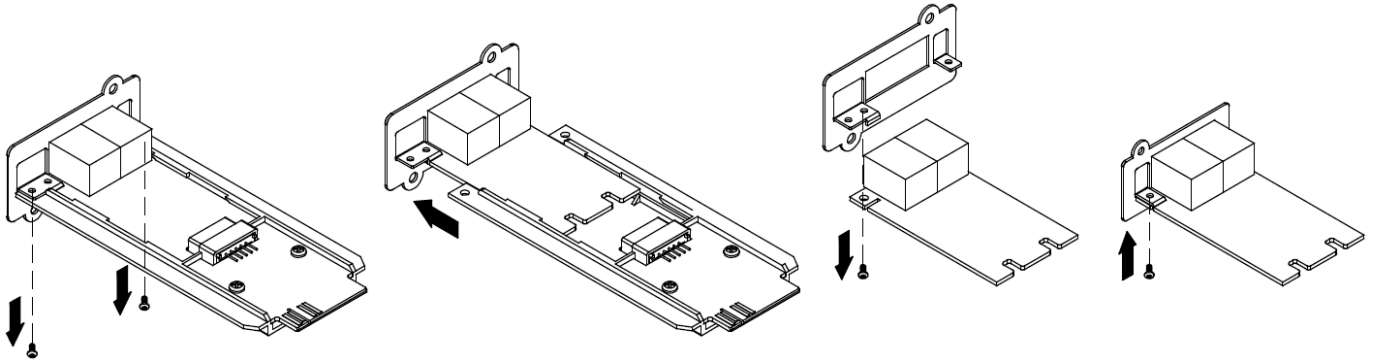

Figure 12. The PowerPanel® Business Edition Client web interface.

Appendix 5: RMCARD Adapter Guide

Remove the Adapter to convert an RMCARD305 to an RMCARD205



Step 1. Remove the two screws from the adapter holding the card in place.

Step 2. Remove the card from the adapter.

Step 3. Remove the screw holding the RMCARD305 front panel to the card.

Step 4. Attach the RMCARD205 front panel to the card.

Add the adapter to convert an RMCARD205 to an RMCARD305

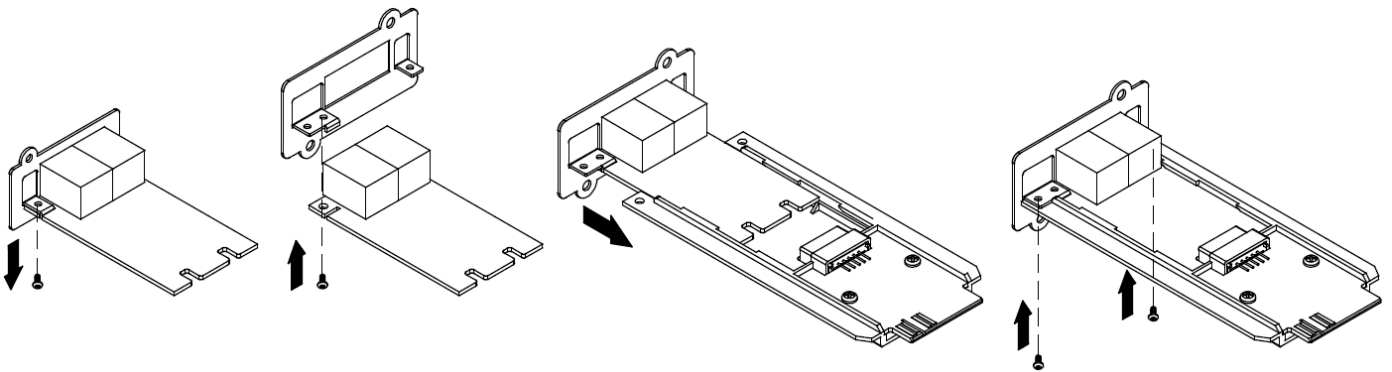

Step 1. Remove the screw holding the front panel to the card and remove the RMCARD205 front panel.

Step 2. Screw on the RMCARD305 front panel to the card.

Step 3. Insert the card into the adapter. Ensure that the card is securely seated in place.

Step 4. Use the two adapter screws to secure the card in place.

Note: The RMCARD Adapter Kit is not included with the RMCARD205. Please contact CyberPower for ordering information or Technical Support.

Note: RMCARD205 is designed for the 43x18mm (1.69x0.71inch) SNMP card expansion port of CyberPower PR, OR, and 1-3kVA OL series UPS, and ATS PDU. RMCARD305 is designed for the 57x23mm (2.24x0.91inch) SNMP card expansion port of CyberPower OL6-10kVA series UPS.



CyberPower

CyberPower Systems, Inc.

www.cyberpowersystems.com

For USA and Canada:

4241 12th Ave East, Suite 400

Shakopee, MN 55379

Toll-free: (877) 297-6937

For all other regions:

Please visit our website for local contact information.

