





IMPORTANT SAFETY INSTRUCTIONS

- 1) Read these instructions.
- 2) Keep these instructions.
- 3) Heed all warnings.
- 4) Follow all instructions.
- 5) Do not use this apparatus near water.
- 6) Clean only with a dry cloth.
- 7) Install in accordance with the manufacturer's instructions.
- 8) Do not install near any heat sources such as radiators, heat registers, stoves or other apparatus (including DVRs) that produce heat.
- 9) Do not defeat the safety purpose of the polarized or grounding-type plug. A polarized plug has two blades with one wider than the other. A grounding type plug has two blades and a third grounding prong. The wider blade or the third prong are provided for your safety. If the provided plug does not fit into your outlet, consult an electrician for replacement of the obsolete outlet.
- 10) Protect the power cord from being walked on or pinched particularly at plugs, convenience receptacles, and the point where they exit from the apparatus.
- 11) Only use attachments/accessories specified by the manufacturer.
- 12) Refer all servicing to qualified service personnel. Servicing is required when the apparatus has been damaged in any way, such as a power supply cord or plug is damaged, liquid has been spilled, or objects have fallen into the apparatus, the apparatus has been exposed to rain or moisture, does not operate normally, or has been dropped. This installation should be made by a qualified service person and should conform to all local codes.

TO REDUCE THE RISK OF ELECTRICAL SHOCK, DO NOT REMOVE COVER OR BACK. NO USER SERVICEABLE PARTS INSIDE. REFER SERVICING TO QUALIFIED SERVICE PERSONNEL.

WARNING: TO REDUCE THE RISK OF ELECTRICAL SHOCK, DO NOT EXPOSE THIS APPARATUS TO RAIN OR MOISTURE.

 This installation should be made by a qualified service person and should conform to all local codes.

 **WARNING** - Do not install the unit in an environment where the operating ambient temperature exceeds 120° F (50° C). The ventilation should not be impeded by covering the unit with items, such as newspapers, table-cloths, curtains, etc. No naked flame sources, such as lighted candles should be placed on the apparatus.

  **WARNING** - Do not interconnect multiple power supply outputs.

 **WARNING** - The apparatus shall not be exposed to dripping or splashing and no objects filled with liquids, such as vases, shall be placed on the apparatus.

 **WARNING** - Use only a Certified power cord and plug (coupler / mains) assemblies for location installed.

 **WARNING** - Power cord is regarded as main disconnect.

 **WARNING** - The appliance coupler (power cord/mains) shall remain readily operable.

 **WARNING** - For safety, never put NVT signals in the same conduit as high-voltage wiring.



Network Video Technologies

4005 Bohannon Drive • Menlo Park, CA 94025 • USA

(+1) 650.462.8100 • FAX (+1) 650.326.1940

nvt.com • www.nvt.com/email

PRODUCT OVERVIEW

Model NV-EC1701 Ethernet over Coax EoC Transceiver with PoE Power



Features:

- Transmit 10/100 BaseT Full Duplex Ethernet up to 2,500ft (750m)* over RG-59 (or similar)
- Powers PoE cameras (or other PoE devices), up to 45 watts
- One EoC transceiver at the network-end can support up to four remote transceivers/IP cameras using an NVT BNC adaptor/splitter
- Up to four transceivers can be rack mounted on an NV-RMEC16 Rack Mount Tray Kit, connecting up to 16 cameras
- 48VDC is distributed over the coax to all connected equipment
- Easy configuration, no PC required
- Transparently supports all networking protocols (UDP, TCP/IP, HTTP, etc.)
- Advanced 128-bit AES encrypted transmission and power technology with built-in transient protection
- Available in 1-4 Camera System Kits
- Up to four EoC transceivers can be rackmounted on an NV-RMEC16 Rack Mouning Tray Kit, connecting up to 16 cameras
- Limited lifetime warranty

The NVT Model NV-EC1701 Ethernet over Coax EoC Transceiver is a compact media converter that allows 10/100 BaseT Ethernet and PoE power to be transmitted using coax cable. These EoC devices are typically used in legacy installations where existing coax is re-deployed as part of an upgrade to IP cameras. 48 VDC class 2 power is delivered to one transceiver, which distributes it to up to four remote transceivers, and their PoE cameras.

These transceivers are extremely simple to use, with no IP or MAC addressing required. Status LEDs indicate power and link connectivity/activity for RJ45 and BNC ports. The NV-EC1701 is backed by NVT's award winning customer support and limited lifetime warranty.

* Distance and number of devices supported will often be lower due to power delivery voltage-drop on the wire. See Wire Distance Chart.

CONFIGURATION INSTRUCTIONS

NV-EC1701 EoC transceivers transmit high bandwidth encrypted Ethernet signals over conventional coax cables. To provide utmost signal integrity and security, NVT EoC transceivers **must be configured** to communicate exclusively with other transceivers within their **Network Group**. This group typically consists of one NV-EC1701 located at the control room (usually connected to an ethernet switch or router), and up to four remote NV-EC1701 transceivers (usually connected to IP cameras).

Before connecting to the network, **each NV-EC1701 must learn which other NV-EC1701 transceivers are to be part of that group**. This simple process is called **Joining**. It is recommended that transceivers in each Network Group be configured **prior to deployment** using these instructions:

Step One: Gather Materials

- Up to five NV-EC1701 transceivers
- 48VDC power supply & line-cord (NV-PS48-60W)
- Coax jumper
- Small paper-clip, partially straightened
- Device labels
- IP Network Documentation Log



Step One: Gather Materials

Step Two: Connect Hardware

- Remove and discard the "Configure Before Use" labels.
- Connect two NV-EC1701 transceivers using a coax jumper.
- Connect 48VDC power supply to one transceiver; Apply power.
- Verify that the blue POWER LED on each transceiver illuminates.
- Verify that the green BNC LED on each transceiver is off.
If a BNC LED is on, the transceiver has been previously joined. Perform the un-joining process below before proceeding.



Step Two: Remove Label; Connect Hardware

Step Three: Joining

- On one transceiver, using the straightened paper-clip, momentarily depress the small push-button located behind and slightly above the RJ45 LED. The RJ45 LED will begin blinking.
- Depress the same push-button on the second transceiver.
- Both transceivers are now in **Join Mode**. They will find each other and establish encrypted communication. In about 10 seconds, the BNC LEDs on both transceivers will illuminate (blinking or steady on), and the RJ45 LED will go off, indicating a successful **Join**.



Step Four: Adding Transceivers (if required)

- Disconnect one of the transceivers and replace it with a new un-joined transceiver.
- Repeat steps two and three to add additional (up to five total) transceivers to the same Network Group.

Step Five: Documentation

- Label the configured transceivers with a unique Network Group ID of your choice. This will help you identify them after they have been deployed.
- Record this Network Group information in your IP Network Documentation Log. This log may include essential documentation which will help you identify all system devices during and after deployment:
 - Camera Number
 - Camera Position/Location
 - Camera Make & Model
 - Camera MAC & IP Address
 - Camera Login & Password
 - Camera-end NVT Transceiver MAC Address
 - NVT Transceiver Network Group Name
 - Control Room NVT Transceiver MAC Address
 - Control Room Router Port Number



Step Three: transparent view of push-button location

Un-Joining a Transceiver

If you need to move a transceiver from one Network Group to another, it must first un-learn its previous Network Group and be returned to an un-joined state. Do this by applying 48VDC power, and pressing the small push-button located behind and slightly above the RJ45 LED for four seconds until the BNC and RJ45 LEDs illuminate and then go out, about 10 seconds. The transceiver is now ready to be joined to a new Network Group, as outlined above.



Step Five: Transceiver MAC Address

INSTALLATION INSTRUCTIONS

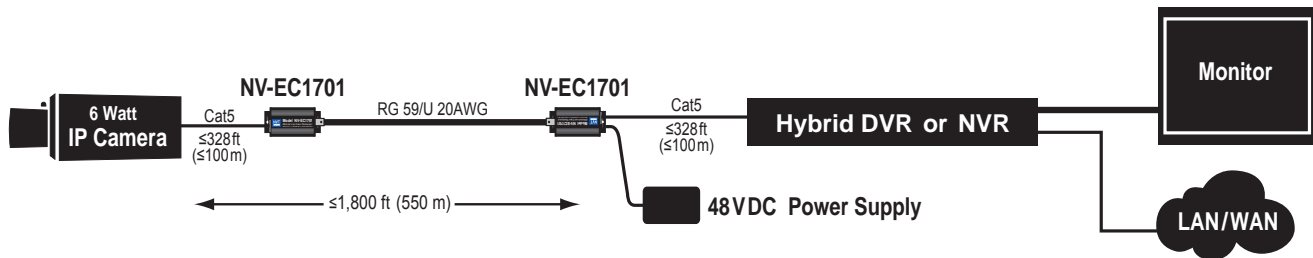

Figure 1 - Typical Installation

Most installations that use the NV-EC1701 transceiver involve the replacement of an analog camera with an IP camera, while reusing the installed coax cable. Since most IP cameras support PoE (Power over Ethernet), the legacy 24VAC distribution may no longer be needed.

⚠ Disconnect all analog equipment from the coax before installing the IP equipment. The NV-EC1701 uses the coax to deliver 48V DC. To prevent damage, never connect analog cameras or analog control-room equipment to an NV-EC1701.

Transceiver Configuration

NVT EoC transceivers **must be configured** to communicate exclusively with other transceivers within their **Network Group**. The configuration process is described on page 3.

Connecting the Camera End

Install the new IP camera. Mount the NV-EC1701 nearby. Connect the enclosed grey RJ45 patch cable between the network connector (PoE) of the camera and the RJ45 jack on the NV-EC1701. Connect the coax to the BNC jack on the NV-EC1701.

For most installations, the IP camera power will be low enough, and the coax distance short enough, so that the IP camera and its NV-EC1701 can receive power through the coax. In most cases, a power supply will not be needed at this end. For additional details, see “High Power Extended Distance Considerations” on page 7.

Connecting the Control-room End

Install a second NV-EC1701 at the control-room end of the coax cable.

If rack-mounting is desired, use the NV-RMEC16 tray, which supports up to four NV-EC1701 transceivers, which together can support up to 16 cameras.

Connect the coax cable to the BNC jack on the NV-EC1701.

Connect a class 2 (SELV) 48VDC power supply to the jack labeled “48VDC” on the NV-EC1701.

This will provide power to the entire system, including the cameras. The Blue “Power” LEDs will illuminate on both transceivers.

Connect the enclosed red RJ45 patch-cord between the RJ45 jack on the NV-EC1701 and either: 1) an IP camera video input on a Hybrid DVR, or 2) an Ethernet switch allocated for video. See “Hybrid DVR Considerations” on page 5, or “NVR Considerations” on page 6.

The Green LEDs will illuminate when a network link is established, and will blink when data traffic is present.

MULTIPLE CAMERAS

The NV-EC1701 communicates via the coax using a bus-architecture. This means that up to four remote camera-end NV-EC1701s may be connected together to a fifth NV-EC1701 at the control-room. The coax cables are connected together using BNC splitters, available from NVT, or elsewhere. If you purchase BNC “T” connectors from another supplier, please purchase high quality connectors. Low cost connectors have been found to have intermittent shield connections.



NV-BNCT



NV-EC4BNC

Multiple IP cameras draw more current. To ensure adequate power, see “High Power Extended Distance Considerations” on page 7.

PoE CONSIDERATIONS

For rev B and B1 transceivers, the 48V is “always on.” Use the enclosed red RJ45 patch cord to connect to control-room hubs or non-PoE equipment.

NVT’s Class 2 current limiting ensures safety of the installation during fault conditions, while delivering higher power (up to 45 watts) with more efficient allocation amongst loads.

Unlike conventional PoE, voltage-drop and load current must be confirmed by the installer. See “High Power Extended Distance Considerations” on page 7.

HYBRID DVR CONSIDERATIONS

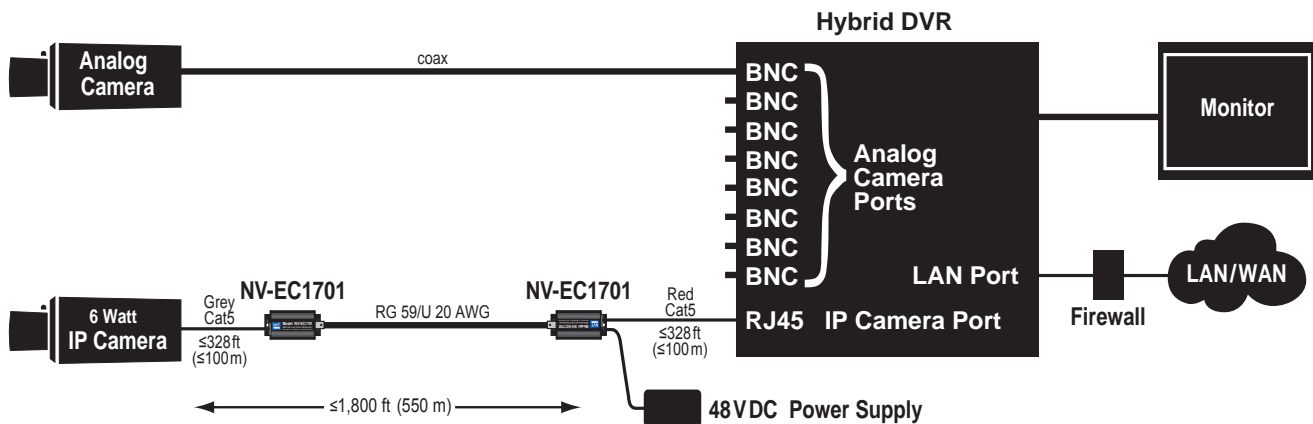

Figure 2 - Hybrid DVR Installation

TRANSCIVER-TO-TRANSCIVER

The NV-EC1701 transceivers provide transparent end-to-end 10-baseT or 100-BaseT connectivity with auto detection and auto-crossover. This means that IP cameras or other devices may be installed at one end, and their data is transparently delivered to the other end. Before installing, transceivers must be configured per the instructions on page 3.

Long coax distances up to 2,500 ft (750m) are supported, although local power may be required for extended distances. See “High Power Extended Distance Considerations” on page 7.

The NV-EC1701 supports all standard protocols, such as TCP/IP, UDP, HTTP, etc. This allows for the transmission of other network traffic besides streaming video.

HYBRID DVR ARCHITECTURE

The NV-EC1701 is network transparent, and operates in virtually every network environment, including support for Hybrid DVRs. These DVRs have some BNC ports for analog cameras, and some RJ45 ports for IP cameras. The RJ45 “video in” port is the connection point for the NV-EC1701. See figure 2.

By deploying a Hybrid DVR, with its dedicated IP camera port(s), the network is robust and secure, with none of the traffic, hacking, or virus vulnerabilities associated with PC-like hardware on an open LAN.

Depending on the Hybrid DVR, more than one camera may be connected to its IP camera port. Check the Hybrid DVR manual for details.

NVR CONSIDERATIONS

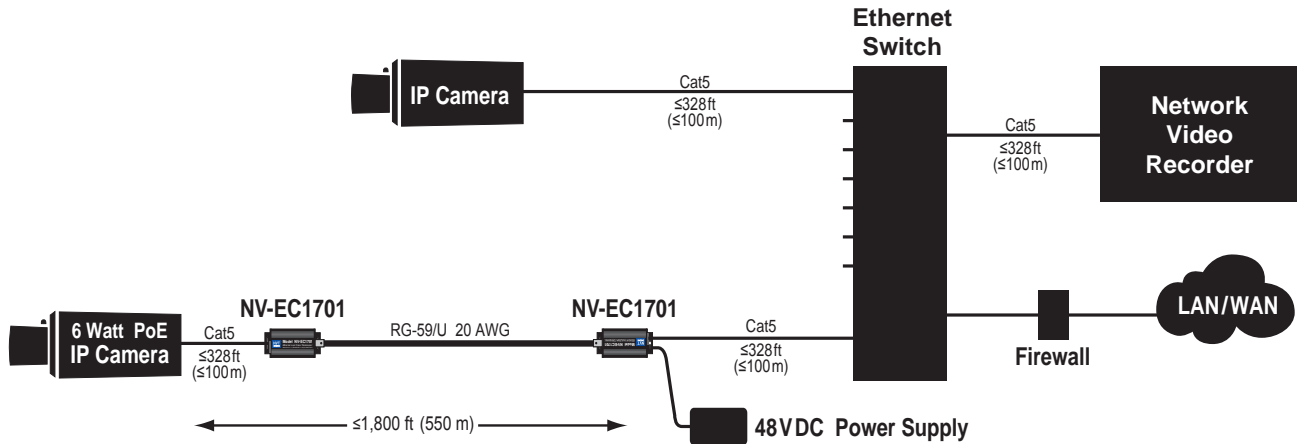

Figure 3 - NVR Installation

TRANSCIVER-TO-TRANSCIVER

The NV-EC1701 transceivers provide transparent end-to-end 10-baseT or 100-BaseT connectivity with auto detection and auto-crossover. This means that IP cameras or other devices may be installed at one end, and their data is transparently delivered to the other end. Please read configuration instructions on page 3 before installing.

Long coax distances up to 2,500 ft (750 m) are supported, although local power may be required for extended distances. See “High Power Extended Distance Considerations” on page 7.

The NV-EC1701 supports all standard protocols, such as TCP/IP, UDP, HTTP, etc. This allows for the transmission of other network traffic besides streaming video.

NETWORK ARCHITECTURE

The NV-EC1701 is network transparent, and operates in virtually every network environment.

For IP-based CCTV applications, there are some network configurations that are robust, and others that are not recommended. **In general, it is best to deploy a separate LAN exclusively for video traffic.**

Although it is possible to place IP cameras onto the end-user’s “Enterprise LAN”, there are several disadvantages in doing so. These include:

Traffic Management Considerations

When sharing the resources of a LAN, the nature of the traffic must be well understood for it to operate efficiently. For most end-users, the business use of their LAN is constantly changing, critical for their day-to-day operations, and not managed by the same group that manages their security. IP video can often consume large amounts of bandwidth, which may or may not be compatible with existing IT traffic.

Security Considerations

Most surveillance systems are installed specifically to protect against breaches in security. A shared LAN provides potential opportunities for unauthorized access to security assets. Sniffing IP addresses can result in the unintended disclosure of IP cameras or network vulnerabilities. Spoofing IP addresses could result in the disruption of recording.

If you must pass IP camera video through “public” LANs, ensure that video is recorded prior to leaving the secure LAN. Then encrypt it by using a Virtual Private Network (VPN) so that neither the video, nor its addressing is readable on the LAN. Many low-cost routers support VPNs.

HIGH POWER EXTENDED DISTANCE CONSIDERATIONS

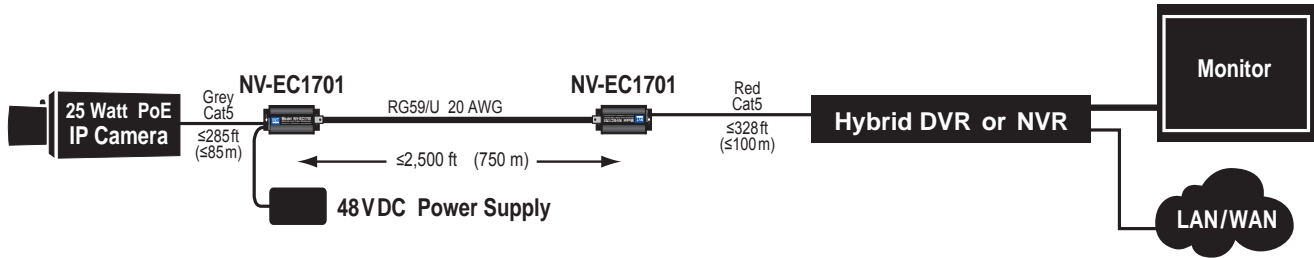

Figure 4 - Alternate Power Supply Location

The NV-EC1701 has a power inlet connector that receives 48 volts from an external Class 2 SELV desk-style power supply. For multi-camera systems sharing a 60W power supply, the sum of all camera wattages, plus the sum of all transceivers wattages (at 2 watts each) shall not exceed 50 watts.

Power is distributed “always on” to:

- 1) the transceiver’s internal electronics;
- 2) the RJ45 (pins 5&4 and 7&8) to provide power to the PoE camera, if connected. Non-PoE equipment should be connected through the enclosed red RJ45 patch cord, which blocks the 48VDC.
- 3) out to the coax cable, where it is used by the remote NV-EC1701, and its associated PoE camera.

The wire resistance causes the voltage to drop, depending on the load current. If the voltage is too low at the far end, the remote equipment will not operate correctly. Below are recommended maximum wire distances.

For a 6 watt IP camera, the maximum distance is 1,800ft (600m), with shorter distance for higher-power cameras.

Longer distances can still be achieved if the IP camera-end transceiver is locally powered. In this case, the Cat5 or Cat6 cable resistance applies. The camera-end power supply is capable of powering the control-room transceiver, up to 2,500 ft (750 m). See figure 4.

WIRE DISTANCE CHARTS

Remote Power Delivery		Supported Wire Distance (feet)					
		Low Grade CATV		Typical CCTV Quality		Extended Distance	
Camera Power	Maximum Wire Resistance	RG59/BU 22 AWG Copper Clad Steel	RG59/BU 20 AWG Copper Clad Steel	RG59/U 22 AWG Solid Bare Copper	RG59/U 20 AWG Solid Bare Copper	RG6 18 AWG Solid Bare Copper	RG11 14 AWG Solid Bare Copper
(Watts)	(Ohms)	76.0 Ω per 1000 ft	49.4 Ω per 1000 ft	17.4 Ω per 1000 ft	12.7 Ω per 1000 ft	9.10 Ω per 1000 ft	3.70 Ω per 1000 ft
45 W	4.4 Ω	58 ft	90 ft	255 ft	350 ft	488 ft	1,201 ft
35 W	5.6 Ω	74 ft	113 ft	322 ft	441 ft	615 ft	1,514 ft
30 W	6.4 Ω	85 ft	130 ft	370 ft	507 ft	707 ft	1,740 ft
25 W	7.6 Ω	100 ft	153 ft	435 ft	596 ft	832 ft	2,045 ft
20 W	9.2 Ω	121 ft	186 ft	528 ft	723 ft	1,009 ft	2,481 ft
18 W	10 Ω	132 ft	203 ft	577 ft	790 ft	1,103 ft	2,500 ft
15 W	12 Ω	153 ft	236 ft	670 ft	918 ft	1,281 ft	2,500 ft
12 W	14 Ω	183 ft	282 ft	799 ft	1,095 ft	1,529 ft	2,500 ft
10 W	16 Ω	210 ft	323 ft	917 ft	1,256 ft	1,753 ft	2,500 ft
8 W	19 Ω	246 ft	379 ft	1,075 ft	1,472 ft	2,055 ft	2,500 ft
6 W	23 Ω	297 ft	457 ft	1,297 ft	1,800 ft	2,500 ft	2,500 ft
5 W	25 Ω	331 ft	509 ft	1,446 ft	1,981 ft	2,500 ft	2,500 ft
4.5 W	27 Ω	351 ft	540 ft	1,533 ft	2,101 ft	2,500 ft	2,500 ft
4.0 W	28 Ω	374 ft	575 ft	1,632 ft	2,236 ft	2,500 ft	2,500 ft
3.5 W	30 Ω	399 ft	614 ft	1,744 ft	2,390 ft	2,500 ft	2,500 ft

For multi-camera systems sharing a 60W power supply, the sum of all camera wattages, plus the sum of all transceivers wattages (at 2 watts each) shall not exceed 50 watts.

Remote Power Delivery		Supported Wire Distance (meters)					
		Low Grade CATV		Typical CCTV Quality		Extended Distance	
Camera Power	Maximum Wire Resistance	RG59/BU 22 AWG Copper Clad Steel	RG59/BU 20 AWG Copper Clad Steel	RG59/U 22 AWG Solid Bare Copper	RG59/U 20 AWG Solid Bare Copper	RG6 18 AWG Solid Bare Copper	RG11 14 AWG Solid Bare Copper
(Watts)	(Ohms)	24.9 Ω per 100 m	16.2 Ω per 100 m	5.71 Ω per 100 m	4.17 Ω per 100 m	2.98 Ω per 100 m	1.21 Ω per 100 m
45 W	4.4 Ω	18 m	27 m	78 m	107 m	149 m	366 m
35 W	5.6 Ω	22 m	35 m	98 m	134 m	188 m	461 m
30 W	6.4 Ω	26 m	40 m	113 m	155 m	216 m	530 m
25 W	7.6 Ω	30 m	47 m	133 m	182 m	254 m	624 m
20 W	9.2 Ω	37 m	57 m	161 m	220 m	308 m	750 m
18 W	10 Ω	40 m	62 m	176 m	241 m	336 m	750 m
15 W	12 Ω	47 m	72 m	204 m	280 m	391 m	750 m
12 W	14 Ω	56 m	86 m	244 m	334 m	466 m	750 m
10 W	16 Ω	64 m	98 m	279 m	383 m	534 m	750 m
8 W	19 Ω	75 m	115 m	328 m	449 m	627 m	750 m
6 W	23 Ω	91 m	139 m	395 m	550 m	750 m	750 m
5 W	25 Ω	101 m	155 m	441 m	604 m	750 m	750 m
4.5 W	27 Ω	107 m	165 m	467 m	640 m	750 m	750 m
4.0 W	28 Ω	114 m	175 m	498 m	682 m	750 m	750 m
3.5 W	30 Ω	122 m	187 m	532 m	729 m	750 m	750 m

For multi-camera systems sharing a 60W power supply, the sum of all camera wattages, plus the sum of all transceivers wattages (at 2 watts each) shall not exceed 50 watts.

SINGLE 6 WATT CAMERA

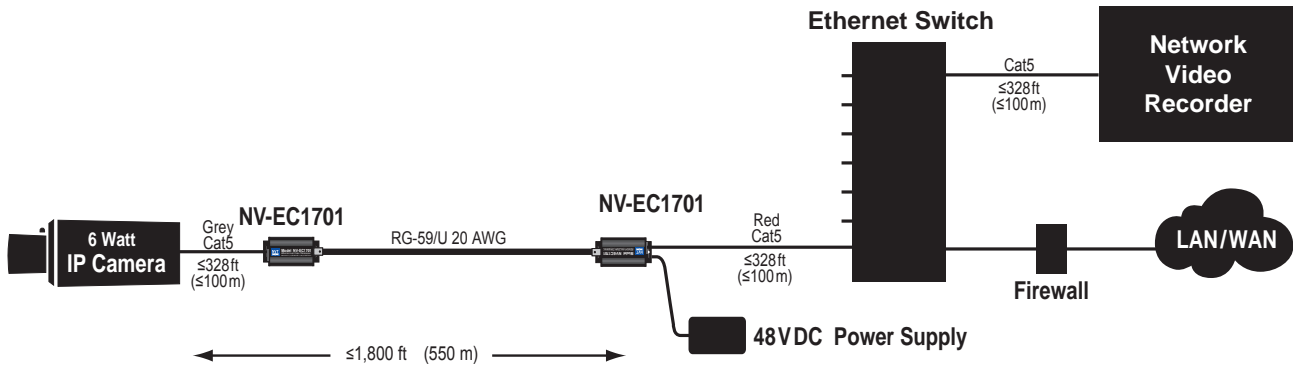

Figure 5 - Single Camera Installation

BILL OF MATERIALS		
NVT MATERIALS		OTHER MATERIALS
2 ea NV-EC1701	EoC Transceiver	1 ea IP or megapixel camera
1 ea NV-PS48-60W	Power Supply	1 ea Camera mount
1 ea NV-PC4PR	RJ45 cable, grey, 4-pair	1 ea RG59 cable
1 ea NV-PC2PR	RJ45 cable, red, 2 pair	3 ea RJ45 cable
This hardware may be purchased as a system kit: NV-EC1701-KIT1		1 ea Ethernet switch
		1 ea Network video recorder

DUAL 6 WATT CAMERA

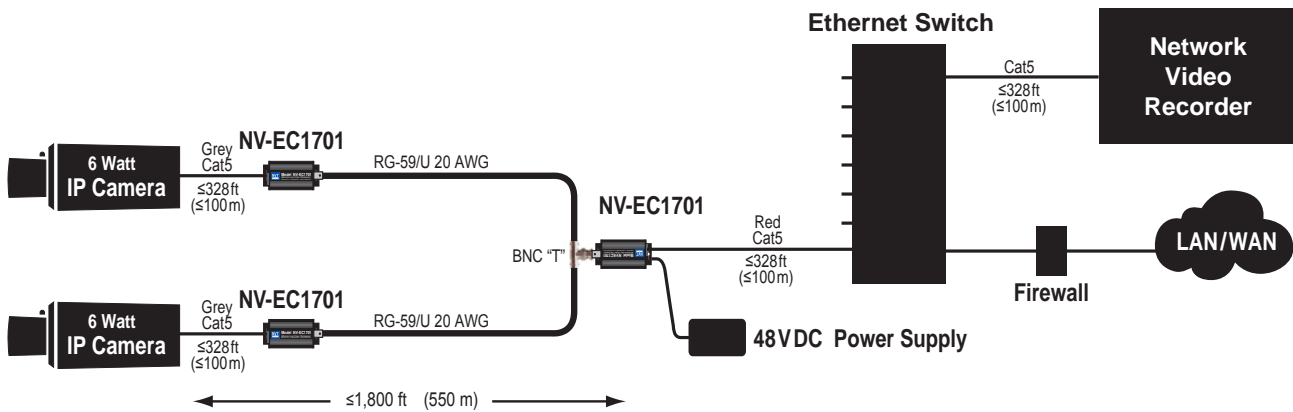

Figure 6 - Dual Camera Installation

BILL OF MATERIALS		
NVT MATERIALS		OTHER MATERIALS
3 ea NV-EC1701	EoC Transceiver	2 ea IP or megapixel camera
1 ea NV-PS48-60W	Power Supply	2 ea Camera mount
1 ea NV-PC4PR	RJ45 cable, grey, 4-pair	2 ea RG59 cable
1 ea NV-PC2PR	RJ45 cable, red, 2 pair	3 ea RJ45 cable
1 ea NV-BNCT	BNC "T" Connector	1 ea Ethernet switch
This hardware may be purchased as a system kit: NV-EC1701-KIT2		1 ea Network video recorder

DAISY-CHAINED COAX

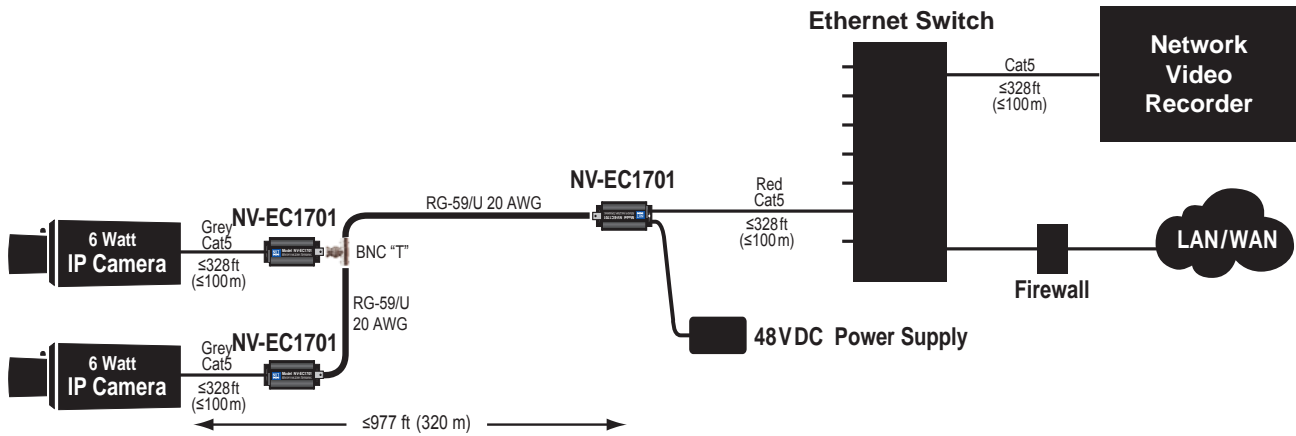

Figure 7 - Daisy-Chain Installation

BILL OF MATERIALS

NVT MATERIALS		OTHER MATERIALS
3 ea	NV-EC1701	EoC Transceiver
1 ea	NV-PS48-60W	Power Supply
2 ea	NV-PC4PR	RJ45 cable, grey, 4-pair
1 ea	NV-PC2PR	RJ45 cable, red, 2 pair
1 ea	NV-BNCT	BNC "T" Connector
		2 ea IP or megapixel camera
		2 ea Camera mount
		2 ea RG59 cable
		3 ea RJ45 cable
		1 ea Ethernet switch
		1 ea Network video recorder

This hardware may be purchased as a system kit: NV-EC1701-KIT2

TRIPLE 6 WATT CAMERA

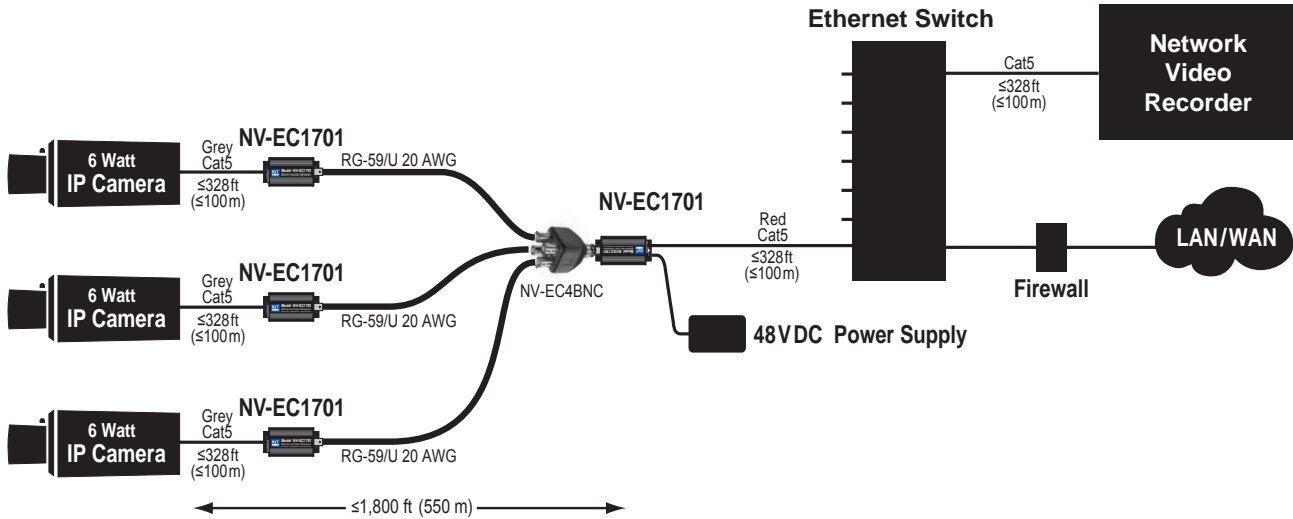

Figure 8 - Triple Camera Installation

BILL OF MATERIALS

NVT MATERIALS		OTHER MATERIALS
4 ea	NV-EC1701	EoC Transceiver
1 ea	NV-PS48-60W	Power Supply
3 ea	NV-PC4PR	RJ45 cable, grey, 4-pair
1 ea	NV-PC2PR	RJ45 cable, red, 2 pair
1 ea	NV-EC4BNC	1:4 BNC Adaptor
		3 ea IP or megapixel camera
		3 ea Camera mount
		4 ea RG59 cable
		3 ea RJ45 cable
		1 ea Ethernet switch
		1 ea Network video recorder

This hardware may be purchased as a system kit: NV-EC1701-KIT3

QUADRUPLE 6 WATT CAMERA

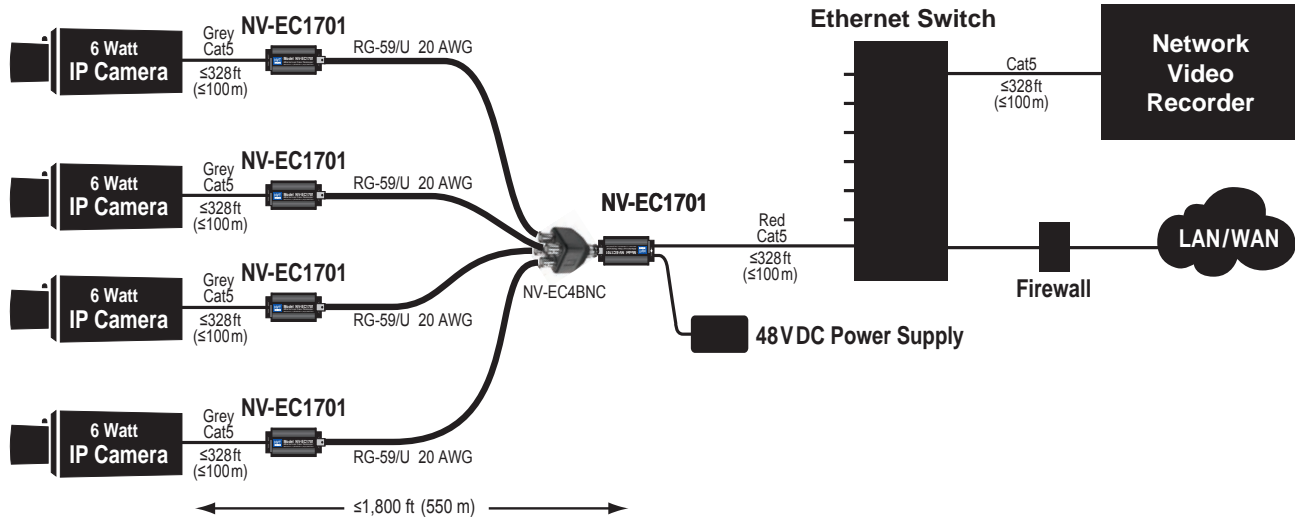

Figure 9 - Quad Camera Installation

BILL OF MATERIALS		
NVT MATERIALS		OTHER MATERIALS
5 ea NV-EC1701	EoC Transceiver	4 ea IP or megapixel camera
1 ea NV-PS48-60W	Power Supply	4 ea Camera mount
4 ea NV-PC4PR	RJ45 cable, grey, 4-pair	6 ea RG59 cable
1 ea NV-PC2PR	RJ45 cable, red, 2 pair	3 ea RJ45 cable
1 ea NV-EC4BNC	1:4 BNC Adaptor	1 ea Ethernet switch
		1 ea Network video recorder

This hardware may be purchased as a system kit: **NV-EC1701-KIT4**

QUADRUPLE 10 WATT CAMERA

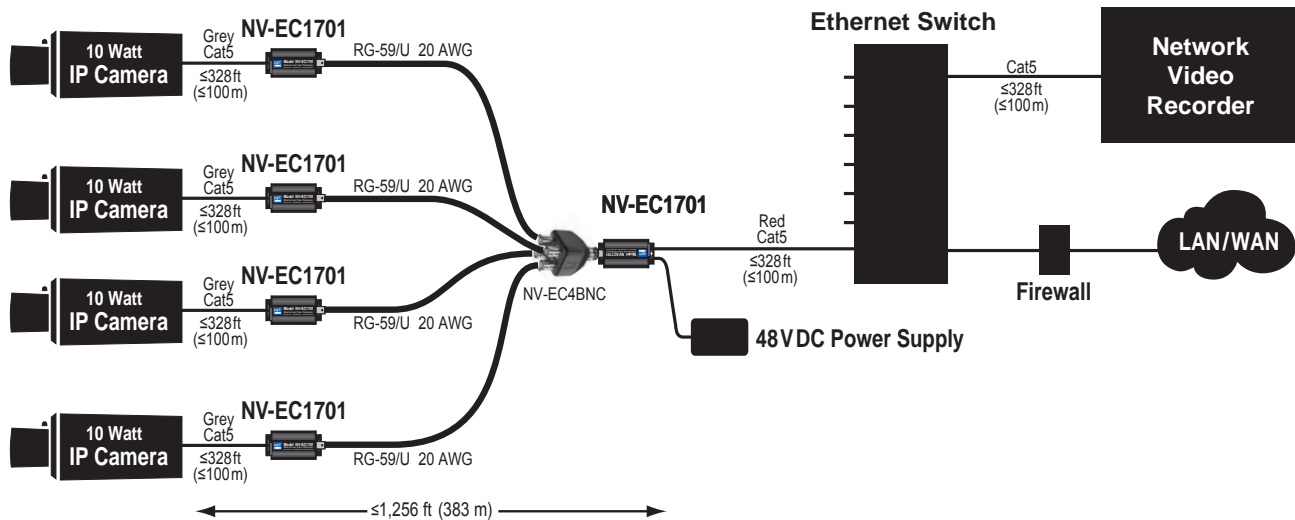

Figure 10 - Quad Camera Installation

BILL OF MATERIALS		
NVT MATERIALS		OTHER MATERIALS
5 ea NV-EC1701	EoC Transceiver	4 ea IP or megapixel camera
1 ea NV-PS48-60W	Power Supply	4 ea Camera mount
4 ea NV-PC4PR	RJ45 cable, grey, 4-pair	6 ea RG59 cable
1 ea NV-PC2PR	RJ45 cable, red, 2 pair	3 ea RJ45 cable
1 ea NV-EC4BNC	1:4 BNC Adaptor	1 ea Ethernet switch
		1 ea Network video recorder

This hardware may be purchased as a system kit: **NV-EC1701-KIT4**

DUAL CAMERA HIGH CURRENT / LONG DISTANCE

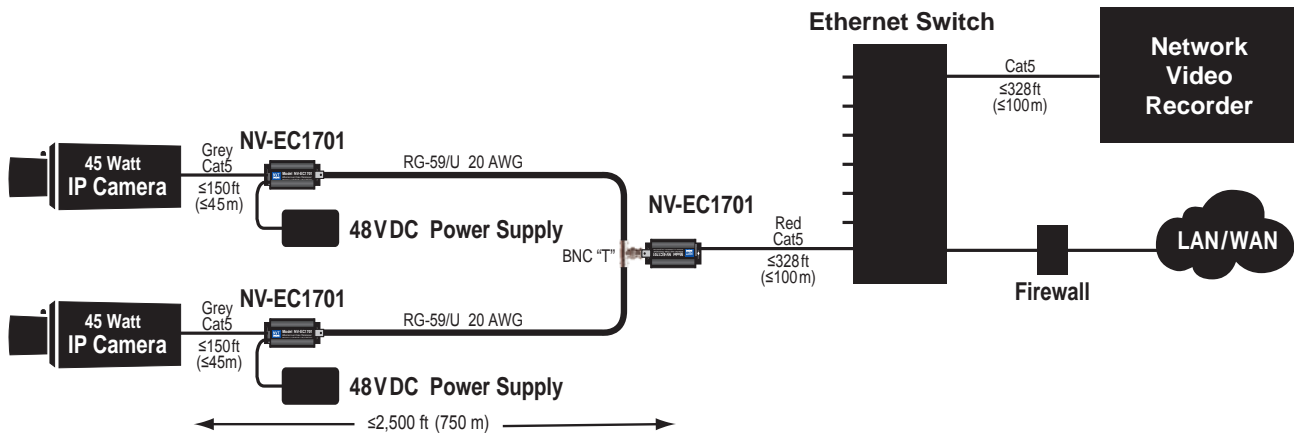

Figure 11 - Dual High-Current Camera Installation

BILL OF MATERIALS

NVT MATERIALS		OTHER MATERIALS
3 ea	NV-EC1701 EoC Transceiver	2 ea IP or megapixel camera
2 ea	NV-PS48-60W Power Supply	2 ea Camera mount
2 ea	NV-PC4PR RJ45 cable, grey, 4-pair	3 ea RJ45 cable
1 ea	NV-PC2PR RJ45 cable, red, 2 pair	2 ea RG59 cable
1 ea	NV-BNCT BNC "T" Connector	1 ea Ethernet switch
		1 ea Network video recorder

QUADRUPLE CAMERA HIGH CURRENT / LONG DISTANCE

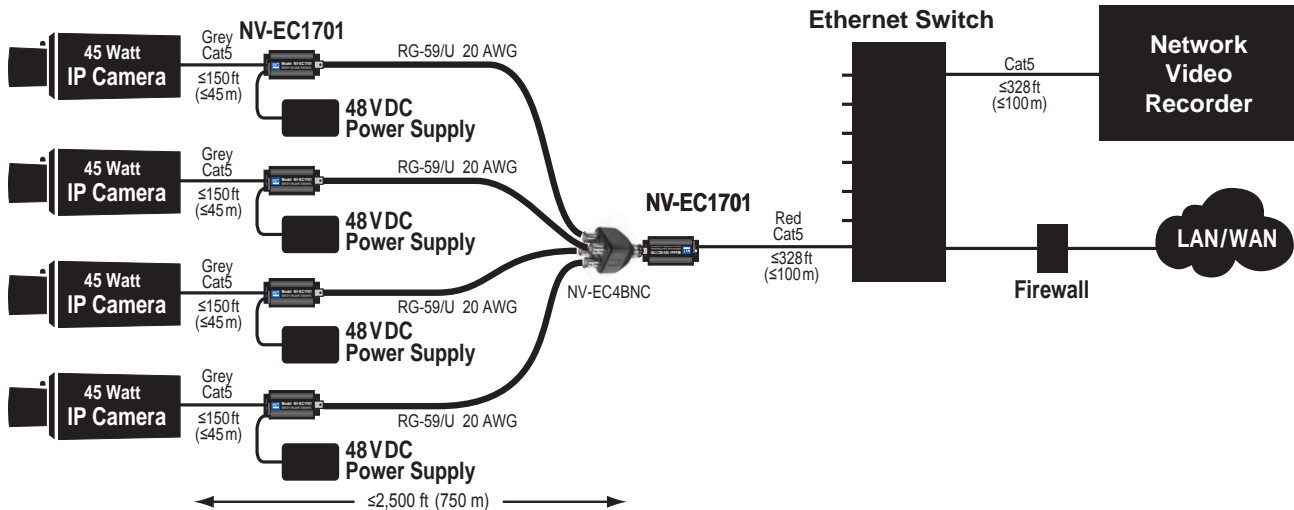

Figure 12 - Quad High-Current Camera Installation

BILL OF MATERIALS

NVT MATERIALS		OTHER MATERIALS
5 ea	NV-EC1701 EoC Transceiver	4 ea IP or megapixel camera
4 ea	NV-PS48-60W Power Supply	4 ea Camera mount
4 ea	NV-PC4PR RJ45 cable, grey, 4-pair	3 ea RJ45 cable
1 ea	NV-PC2PR RJ45 cable, red, 2 pair	6 ea RG59 cable
1 ea	NV-EC4BNC 1:4 BNC Adaptor	1 ea Ethernet switch
		1 ea Network video recorder

QUADRUPLE CAMERAS WITH DIFFERENT CURRENTS / LONG DISTANCE

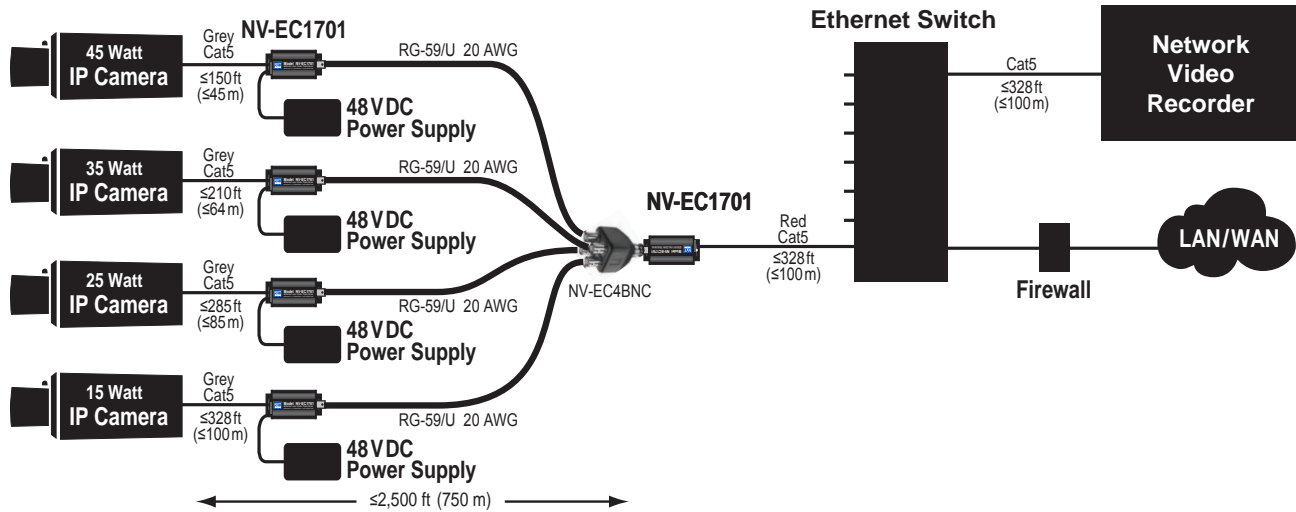

Figure 13 - Quad High-Current Camera Installation

BILL OF MATERIALS

NVT MATERIALS

5 ea	NV-EC1701	EoC Transceiver
4 ea	NV-PS48-60W	Power Supply
4 ea	NV-PC4PR	RJ45 cable, grey, 4-pair
1 ea	NV-PC2PR	RJ45 cable, red, 2 pair
1 ea	NV-EC4BNC	1:4 BNC Adaptor

OTHER MATERIALS

4 ea	IP or megapixel camera
4 ea	Camera mount
3 ea	RJ45 cable
6 ea	RG59 cable
1 ea	Ethernet switch
1 ea	Network video recorder

REMOTE SWITCH LONG DISTANCE

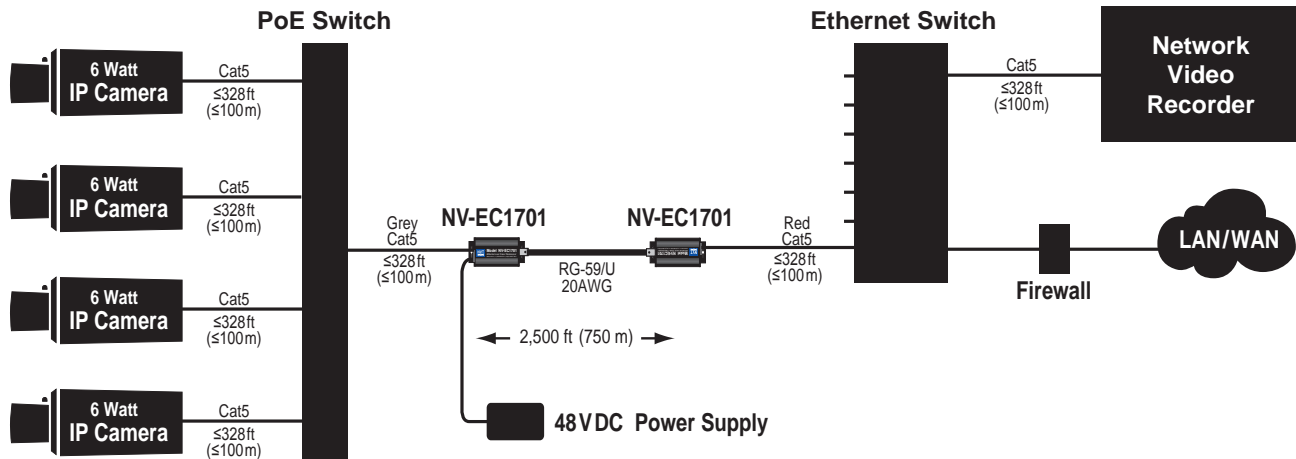

Figure 14 - Remote PoE Switch Redistribution Installation

BILL OF MATERIALS

NVT MATERIALS

2 ea	NV-EC1701	EoC Transceiver
1 ea	NV-PS48-60W	Power Supply
1 ea	NV-PC4PR	RJ45 cable, grey, 4-pair
1 ea	NV-PC2PR	RJ45 cable, red, 2 pair

This hardware may be purchased as a system kit:
NV-EC1701-KIT1

OTHER MATERIALS

4 ea	IP or megapixel camera
4 ea	Camera mount
9 ea	RJ45 cable
1 ea	RG59 cable
2 ea	Ethernet switch
1 ea	Network video recorder

TECHNICAL SPECIFICATIONS

Model NV-EC1701 Ethernet over Coax EoC Transceiver

Technical Specifications

RJ45 ETHERNET INTERFACE

Connectivity: RJ45, auto-crossover
Wire type: 4-pair Cat5 or better
Distance: up to 328ft (100m)
Speed: 10/100 Base T, half/full duplex, auto-negotiation
auto MDI/MDIX cross-over

Latency: 3mS

Data throughput: 80 Mbps \pm 10% useable bandwidth per network
Example: Four megapixel cameras, all sharing one coax network, each sending 20Mbps video stream(s).

Power output: This Power Sourcing Equipment (PSE) supports Powered Devices (PDs) that are compatible with IEEE 802.3af, or PDs that draw up to 45 watts*. "always on" 48VDC outputs appear on pins 4&5 and 7&8, and are current-protected and transient-protected.

COAX BUILDING WIRING INTERFACE

Connectivity: BNC, RG-59/U or similar
One control room EoC transceiver plus up to four remote EoC transceivers are supported

Impedance: 50 to 100 Ω

Distance: up to 2,500 ft (750m)*

Transmission technology: OFDM, 128-bit AES encryption

* IMPORTANT NOTE:

Distance will often be shorter due to power delivery voltage-drop on the wire. See Maximum Per-Camera Wire Distance Chart on page 4. Power supplies may be used simultaneously at more than one EoC Transceiver.

LED STATUS INDICATORS

Power: Blue "Power On"
BNC Interface: Green "Link"
RJ45 Interface: Green "Link"

POWER CONSUMPTION

Consumption per transceiver: 2.0 W @ 48VDC

Total system consumption: = total consumption of transceivers
+ total consumption of PDs (IP cameras)
+ total power dissipated in the wire

POWER SUPPLY

Power supplies are external inline, with an IEC380-C14 power inlet and 6ft (1.8m) line-cord. Input Voltage is 100 ~240VAC 50-60Hz. A molded P1J 5.5mm barrel connector provides a Class 2 (SELV) 48VDC regulated output. Use only the power cord provided with the unit or equivalent UL approved type SPT-2, SVT, or SJT, 18/3 AWG 100~240VAC, 1A 60°C Max. 15ft (4.5m) long.

One end with IEC380-C13 appliance coupler and the other end with NEMA 1015P or equivalent for country.

 + 48VDC

MECHANICAL

Body: 4 in (100mm) long
1.3 in (33mm) high
1.5 in (38mm) wide

Transceiver weight: 4.2oz (120g)
Power supply weight: 10.6oz (300g)
Power cord weight: 5.5oz (160g)
Total weight: 20.3oz (575g)

ENVIRONMENTAL

Operating temperature: 14°F to 122°F (-10°C to +50°C)
Storage temperature: -22°F to 158°F (-30°C to +70°C)
Humidity: 20 to 85% non-condensing

REGULATORY

UL Listed to IEC/UL 60950-1 Complies with FCC part 15B limits

Specifications subject to change without notice.

MODEL NUMBERS

NV-EC1701 Single transceiver only, no power supply



ACCESSORIES

NV-PS48-60W 48V DC power supply, 60 watts with IEC line cord



NV-BNCT BNC "T" adaptor



NV-EC4BNC 1:4 BNC splitter adaptor



NV-PC4PR RJ45 Patch Cord, 4-pair 3' (1m) Grey



NV-PC2PR RJ45 Patch Cord, 2-pair 3' (1m) Red



NV-DSPC4 Detachable Power Supply Cord Splitter



NV-RMEC16 Rack mounting chassis, 19" x 1U holds up to 4 NV-EC1701 transceivers plus power supplies Includes NV-DCPC4 Power Cord Splitter



TRANSCEIVER KITS

Single Camera EoC Transmission System

- NV-EC1701-KIT1 2 NV-EC1701 Transceivers
 1 NV-PS48-60W Power Supply with IEC line cord
 1 NV-PC4PR
 1 NV-PC2PR



Dual Camera EoC Transmission System

- NV-EC1701-KIT2 3 NV-EC1701 Transceivers
 1 NV-PS48-60W Power Supply with IEC line cord
 1 NV-BNCT
 2 NV-PC4PR
 1 NV-PC2PR

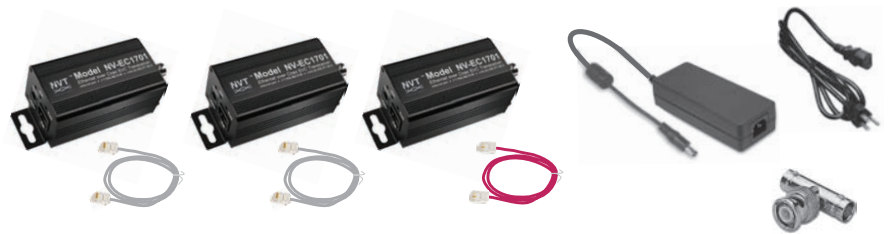

Triple Camera EoC Transmission System

- NV-EC1701-KIT3 4 NV-EC1701 Transceivers
 1 NV-PS48-60W Power Supply with IEC line cord
 1 NV-EC4BNC
 3 NV-PC4PR
 1 NV-PC2PR



Quadruple Camera EoC Transmission System

- NV-EC1701-KIT4 5 NV-EC1701 Transceivers
 1 NV-PS48-60W Power Supply with IEC line cord
 1 NV-EC4BNC
 4 NV-PC4PR
 1 NV-PC2PR



TROUBLESHOOTING

Confirm that the NVT transceivers have been configured to communicate with each-other, per instructions on page 3.

If you are experiencing problems, attempt to simplify your setup. Test each cable segment separately. For example, test the IP camera directly at the ethernet switch without other equipment. Then add in the NVT transceivers, back-to-back. Test each segment of a long cable-run independently. Attempt to isolate the problem.

Most IP camera installation problems involve configuring the IP camera and the recorder to recognize each other. If in doubt, connect the camera directly to the Ethernet switch, bypassing the transceivers. Consult the IP camera and/or recorder installation manuals for configuration instructions, or contact the camera or recorder manufacturer.

CUSTOMER SUPPORT

NVT customer support is available for consultation from 8:00 AM to 5:30 PM PST Monday through Friday. In addition, emergency after-hours callback support is available.

USA Office: (+1) (650) 462-8100
USA Fax: (+1) (650) 326-1940
UK Office: (+44) (0)20 8977 6614
UK Fax: (+44) (0)20 8973 1855
Email USA: www.nvt.com/email/info
Email UK: www.nvt.com/email/eusales
Web home page: www.nvt.com

PRODUCT RETURNS

Please call before returning units to NVT. Returned materials must have a "Returned Materials Authorization" (RMA) number from NVT marked on the outside of the shipping carton.

LIMITED LIFETIME WARRANTY

NVT warrants that the product conforms to NVT's applicable published specifications and is free of defects for the life of the product. There shall be no other warranties, express, statutory, or otherwise, including any implied warranty of merchantability, of fitness, or any other obligation on the part of NVT with respect to any of the products.

In the event that any of the products is damaged, altered, or modified without the express written consent of NVT, any warranty for those products will cease and NVT will have no further liability as it pertains to those products.

NVT assumes no responsibility for damages or penalties incurred resulting from the use of this product in a manner or location other than for which it is intended.

NVT's liability under any warranties shall be discharged by replacing or repairing any part or parts which do not conform to the applicable warranty under normal and proper use. NVT's liability with respect to any product shall not exceed a refund of the price received by NVT for that product, and in no event shall NVT have any liability for any incidental, consequential, special, or indirect damages.

Some states do not allow the exclusion or limitation of special, incidental, or consequential damages, so the above limitations or exclusions may not apply to you. This warranty gives you specific legal rights, and you may also have other rights which vary from state to state.

FCC USER INFORMATION

This equipment has been tested and found to comply with the limits for a Class B digital device, pursuant to part 15 of the FCC Rules. These limits are designed to provide reasonable protection against harmful interference in a residential installation. This equipment generates, uses, and can radiate radio frequency energy and, if not installed and used in accordance with the instructions, may cause harmful interference to radio communications. However, there is no guarantee that interference will not occur in a particular installation. If this equipment does cause harmful interference to radio or television reception, which can be determined by turning the the equipment off and on, the user is encouraged to try to correct the interference by one or more of the following measures:

- Reorient or relocate the receiving antenna.
- Increase the separation between the equipment and the receiver.
- Connect the equipment into an outlet on a circuit different from that to which the receiver is connected.
- Consult the dealer or an experienced radio/TV technician for help.

WARNING

Changes or modifications not expressly approved by the manufacturer could void the user's authority to operate the equipment.



Network Video Technologies

4005 Bohannon Drive • Menlo Park, CA 94025 • USA
(+1) 650.462.8100 • FAX (+1) 650.326.1940
nvt.com • www.nvt.com/email

Copyright © 2011 NVT, Inc.
10/11 453-1701-1-B2