

SONY

3-096-718-13(1)

# CD Radio Cassette-Corder

## Operating Instructions US

### Owner's Record

The model number is located at the bottom and the serial number is located in the battery compartment. Record the serial number in the space provided below. Refer to them whenever you call upon your Sony dealer regarding this product.

Model No. \_\_\_\_\_ Serial No. \_\_\_\_\_

## CFD-G700CP

© 2007 Sony Corporation Printed in China

http://www.sony.net/



## WARNING

**To reduce the risk of fire or electric shock, do not expose this apparatus to rain or moisture.**

To reduce the risk of fire, do not cover the ventilation of the apparatus with newspapers, tablecloths, curtains, etc. And do not place lighted candles on the apparatus.

To reduce the risk of fire or electric shock, do not place objects filled with liquids, such as vases, on the apparatus.

The nameplate and important information concerning safety are located on the bottom exterior.

As the main plug is used to disconnect the unit from the mains, connect the unit to an easily accessible AC outlet. Should you notice an abnormality in the unit, disconnect the main plug from the AC outlet immediately.

The unit is not disconnected from the AC power source (mains) as long as it is connected to the wall outlet, even if the unit itself has been turned off.

Do not expose the batteries (battery pack or batteries installed) to excessive heat such as sunshine, fire or the like for a long time.

Do not install the appliance in a confined space, such as a bookcase or built-in cabinet.



This symbol is intended to alert the user to the presence of uninsulated "dangerous voltage" within the product's enclosure that may be of sufficient magnitude to constitute a risk of electric shock to persons.

This symbol is intended to alert the user to the presence of important operating and maintenance (servicing) instructions in the literature accompanying the appliance.

**CAUTION**  
The use of optical instruments with this product will increase eye hazard.

### Important Safety Instructions

- 1) Read these instructions.
- 2) Keep these instructions.
- 3) Heed all warnings.
- 4) Follow all instructions.
- 5) Do not use this apparatus near water.
- 6) Clean only with dry cloth.
- 7) Do not block any ventilation openings. Install in accordance with the manufacturer's instructions.
- 8) Do not install near any heat sources such as radiators, heat registers, stoves, or other apparatus (including amplifiers) that produce heat.
- 9) Do not defeat the safety purpose of the polarized or grounding-type plug. A polarized plug has two blades with one wider than the other. A grounding type plug has two blades and a third grounding prong. The wide blade or the third prong are provided for your safety. If the provided plug does not fit into your outlet, consult an electrician for replacement of the obsolete outlet.
- 10) Protect the power cord from being walked on or pinched particularly at plugs, convenience receptacles, and the point where they connect to the apparatus.
- 11) Only use attachments/accessories specified by the manufacturer.
- 12) Use only with the cart, stand, tripod, bracket, or table specified by the manufacturer, or sold with the apparatus. When a cart is used, use caution when moving the cart/apparatus combination to avoid injury from tip-over.



- 13) Unplug this apparatus during lightning storms or when unused for long periods of time.
- 14) Refer all servicing to qualified service personnel. Servicing is required when the apparatus has been damaged in any way, such as power-supply cord or plug is damaged, liquid has been spilled or objects have fallen into the apparatus, the apparatus has been exposed to rain or moisture, does not operate normally, or has been dropped.

### Information

**For customers in the USA NOTE**  
This equipment has been tested and found to comply with the limits for a Class B digital device, pursuant to Part 15 of the FCC rules. These limits are designed to provide reasonable protection against harmful interference in a residential installation. This equipment generates, uses, and can radiate radio frequency energy and, if not installed and used in accordance with the instructions, may cause harmful interference to radio

communications. However, there is no guarantee that interference will not occur in a particular installation. If this equipment does cause harmful interference to radio or television reception, which can be determined by turning the equipment off and on, the user is encouraged to try to correct the interference by one or more of the following measures:  
— Reorient or relocate the receiving antenna.  
— Increase the separation between the equipment and receiver.  
— Connect the equipment into an outlet on a circuit different from that to which the receiver is connected.  
— Consult the dealer or an experienced radio/TV technician for help.

This device complies with Part 15 of the FCC rules. Operation is subject to the following two conditions: (1) This device may not cause harmful interference, and (2) this device must accept any interference received, including interference that may cause undesired operation.

You are cautioned that any changes or modifications not expressly approved in this manual could void your authority to operate this equipment.

### Notes on DualDiscs

A DualDisc is a two sided disc product which mates DVD recorded material on one side with digital audio material on the other side. However, since the audio material side does not conform to the Compact Disc (CD) standard, playback on this product is not guaranteed.

### Music discs encoded with copyright protection technologies

This product is designed to playback discs that conform to the Compact Disc (CD) standard. Recently, various music discs encoded with copyright protection technologies are marketed by some record companies. Please be aware that among those discs, there are some that do not conform to the CD standard and may not be playable by this product.

MPEG Layer-3 audio coding technology and patents licensed from Fraunhofer IIS and Thomson.

### For customers in the USA

Please register this product on line at <http://www.sony.com/productregistration>  
Proper registration will enable us to send you periodic mailings about new product, services and other important announcements. Registering your product will also allow us to contact you in the unlikely event that the product needs adjustment or modification. Thank you.

## Specifications

**AUDIO POWER SPECIFICATIONS**  
POWER OUTPUT AND TOTAL HARMONIC DISTORTION  
With 3.2-ohm loads, both channels driven from 1 000 - 10 000 Hz; rated 3 W per channel; minimum RMS power, with no more than 10 % total harmonic distortion in AC operation.  
Woofer with 4-ohm loads, driven from 50 - 150 Hz; rated 6 W minimum RMS power, with no more than 10 % total harmonic distortion in AC operation.

### Other specifications

#### CD player section

System  
Compact disc digital audio system  
Laser diode properties  
Emission duration: Continuous  
Laser output: Less than 44.6 µW  
(This output is the value measurement at a distance of 200 mm from the objective lens surface on the optical pick-up block with 7 mm aperture.)  
Number of channels  
2  
Frequency response  
20 - 20 000 Hz ±1/-2 dB  
Wow and flutter  
Below measurable limit

#### Radio section

Frequency range  
FM: 87.5 - 108 MHz  
AM: 530 - 1 710 kHz  
Antennas  
FM: Telescopic antenna  
AM: Built-in ferrite bar antenna

#### Cassette-corder section

Recording system  
4-track 2 channel stereo  
Fast winding time  
Approx. 150 s (sec.) with Sony cassette C-60  
Frequency response  
TYPE I (normal): 70 - 13 000 Hz

#### General

Speaker  
Full range: 10 cm (4 in.) dia., 3.2 Ω, cone type (2)  
Woofer: 13 cm (5 1/8 in.) dia., 4 Ω, cone type (1)  
Tweeter: 2 cm (1 3/16 in.) dia., (2)  
Input  
Built-in audio cable with stereo-mini plug; Minimum input level 245 mV  
AUDIO IN jack (stereo minijack); Minimum input level 245 mV

#### Outputs

Headphones jack (stereo minijack)  
For 16 - 68 Ω impedance headphones  
Power output  
4 W + 4 W (at 3.2 Ω, 10% harmonic distortion)  
Woofer:  
12 W (at 4 Ω, 10% harmonic distortion)

#### Power requirements

For CD radio cassette-corder:  
120 V AC, 60 Hz  
12 V DC, 8 R20 (size D) batteries  
For remote control:  
3 V DC, 2 R6 (size AA) batteries  
Power consumption  
AC 28 W

#### Battery life

For CD radio cassette-corder:  
**FM recording**  
Sony R20P: approx. 6 h  
Sony alkaline LR20: approx. 18 h

#### Tape playback

Sony R20P: approx. 1.5 h  
Sony alkaline LR20: approx. 6 h

#### CD playback

Sony R20P: approx. 1 h  
Sony alkaline LR20: approx. 4 h

#### Dimensions

Approx. 551 × 247 × 370 mm (w/h/d)  
(21 3/4 × 9 7/8 × 14 1/4 inches) (incl. projecting parts)

#### Mass

Approx. 8.4 kg (18 lb. 9 oz) (incl. batteries)

#### Supplied accessories

AC power cord (1)  
Remote control (1)  
Design and specifications are subject to change without notice.

#### Optional accessories

Sony MDR headphones series

## Basic Operations

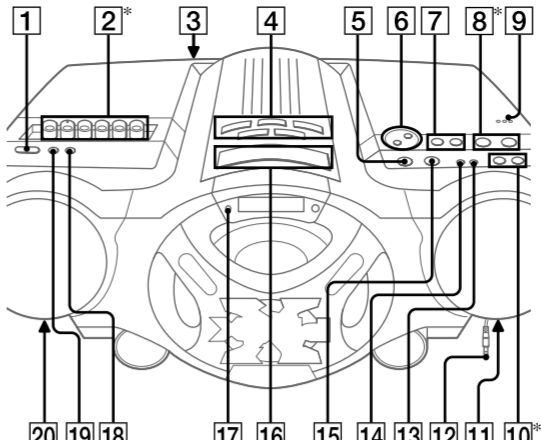

To	Press
Pause playback	▶   on the unit (   on the remote) [8]. To resume play, press it again.
Stop playback	■ [8].
Go to the next track/MP3 file	▶▶ [7].
Go back to the previous track/MP3 file	◀◀ [7].
Select a folder on an MP3 disc	⏏ + to go forward and ⏏ - to go backward [6].
Locate a point while listening to the sound	▶▶ (forward) or ◀◀ (backward) [7] while playing and hold it until you find the point. (◀◀ or ▶▶ [24] on the remote)
Locate a point while observing the display	▶▶ (forward) or ◀◀ (backward) [7] in pause and hold it until you find the point. (◀◀ or ▶▶ [24] on the remote)
Remove the CD	▲ PUSH OPEN/CLOSE [9].

### Tips

- Playback starts from the track/MP3 file you last stopped playing (Resume play). During stop, the track/MP3 file number to be played is displayed.
- To cancel the resume play (to start play from the beginning of the first track/MP3 file), press ■ [8] while the CD is stopped. When you open the CD compartment or turn off the unit, the resume play is also canceled.

### Note

You cannot locate a specific track if "SHUF" or "PGM" is lit in the display. Press ■ [8], and then press MODE [14] repeatedly until "SHUF" and "PGM" disappear from the display.

### Example of folder structure and playing order

The playing order of the folders and files is as follows:

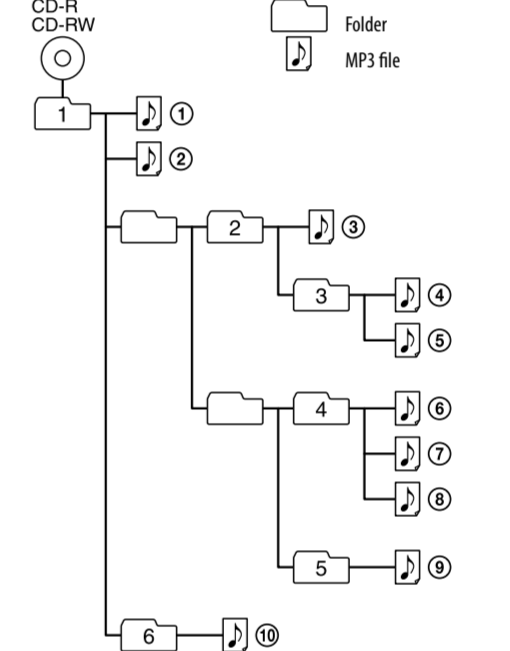

\* VOL + (VOLUME + on the remote) [10], ▶|| [8] and ▶ [2] (on the unit) have a tactile dot.

## Before using the unit

**To turn on/off the power**  
Press POWER [1].

**To adjust the volume**  
Press VOL +, - (VOLUME +, - on the remote) [10].

**To listen through headphones**  
Connect the headphones to the ◯ (headphones) jack [20].

**To select the sound characteristic**  
Press ROCK, DANCE, SALSA, REGGAETON or FLAT [4] to select the kind of audio emphasis that you want. (On the remote, press SOUND [4] repeatedly.)

**To reinforce the bass sound**  
Press POWER DRIVE WOOFER (WOOFER on the remote) [16] to select **WOOFER** or **WOOFER+AA** on the display. **WOOFER+AA** is more effective. When the WOOFER function works, the ring on the front panel lights up.

To return to normal sound, press the button repeatedly until the indication disappears from the display.

- Notes  
• While the sleeping timer is on, the ring does not light, even if the WOOFER function is used.
- When you use the headphones, the WOOFER function does not work.

## Playing a CD/MP3 disc

- 1 Press ▲ PUSH OPEN/CLOSE [9] on the unit, and place a disc with the label side up on the CD compartment.  
To close the CD compartment, press ▲ PUSH OPEN/CLOSE [9] on the unit.

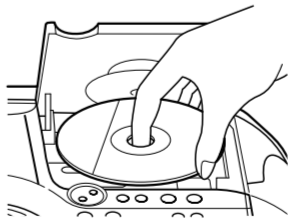

- 2 Press ▶|| on the unit (▶ on the remote) [8].  
The unit plays all the tracks/MP3 files once. When you place MP3 discs, "MP3" appears in the display after the unit reads the file information.

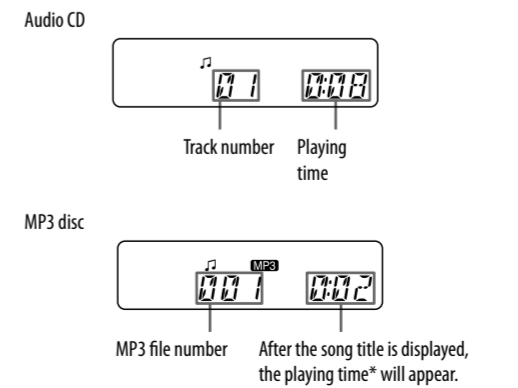

\* If the playing time is more than 100 minutes, it appears "----" in the display.

## SONY LIMITED WARRANTY (U.S. Only)

Sony Electronics Inc. ("Sony") warrants this product against defects in material or workmanship for the time periods and as set forth below when purchased directly from Sony or a Sony Retailer. Pursuant to this Limited Warranty, Sony will, at its option, (i) repair the product using new or refurbished parts or (ii) replace the product with a new or refurbished product. For purposes of this Limited Warranty, "refurbished" means a product or part that has been returned to its original specifications. **In the event of a defect, these are your exclusive remedies.**

**Labor:** For a period of ninety (90) days from the original date of purchase of the product ("Labor Warranty"), Sony will, at its option, repair or replace with new or refurbished product, product determined to be defective. If Sony elects to replace the product after this Labor Warranty has expired but while the Parts Warranty below is still in effect, it will do so for the applicable labor charge.

**Parts:** For a period of one (1) year from the original date of purchase of product ("Parts Warranty"), Sony will supply new or refurbished replacement parts in exchange for parts determined to be defective.

This Limited Warranty covers only the hardware components packaged with the Product. It does not cover technical assistance for hardware or software usage and it does not cover any software products whether or not contained in the Product; any such software is provided "AS IS" unless expressly provided for in any enclosed software Limited Warranty. Please refer to the End User License Agreements included with the Product for your rights and obligations with respect to the software.

**Instructions:** To obtain warranty service, you must deliver the product, freight prepaid, in either its original packaging or packaging affording an equal degree of protection to the Sony authorized service facility specified. **It is your responsibility to backup any data, software or other materials you may have stored or preserved on your unit. It is likely that such data, software, or other materials will be lost or reformatted during service and Sony will not be responsible for any such damage or loss.** A dated purchase receipt from Sony or a Sony Retailer is required. For specific instructions on how to obtain warranty service for your product,

Visit Sony's Web Site:  
[www.sony.com/support](http://www.sony.com/support)  
Or call the Sony Customer Information Service Center  
1-800-222-SONY (7669)  
For an accessory or part not available from your authorized dealer, call:  
1-800-488-SONY (7669)

**Repair / Replacement Warranty:** This Limited Warranty shall apply to any repair, replacement part or replacement product for the remainder of the original Limited Warranty period or for ninety (90) days, whichever is longer. Any parts or product replaced under this Limited Warranty will become the property of Sony.

This Limited Warranty only covers product issues caused by defects in material or workmanship during ordinary consumer use; it does not cover product issues caused by any other reason, including but not limited to product issues due to commercial use, acts of God, misuse, limitations of technology, or modification of or to any part of the Sony product or product purchased from other than Sony or a Sony Retailer. To determine if a retailer is part of the Sony Retailer Network, please contact Sony's Customer Service Call Center or go to [www.sony.com/support](http://www.sony.com/support). This Limited Warranty does not cover Sony products sold AS IS or WITH ALL FAULTS or consumables (such as fuses or batteries). This Limited Warranty is invalid if the factory-applied serial number has been altered or removed from the product. This Limited Warranty is valid only in the United States.

**LIMITATION ON DAMAGES:** SONY SHALL NOT BE LIABLE FOR ANY INCIDENTAL OR CONSEQUENTIAL DAMAGES FOR BREACH OF ANY EXPRESS OR IMPLIED WARRANTY ON THIS PRODUCT.

**DURATION OF IMPLIED WARRANTIES:** EXCEPT TO THE EXTENT PROHIBITED BY APPLICABLE LAW, ANY IMPLIED WARRANTY OF MERCHANTABILITY OR FITNESS FOR A PARTICULAR PURPOSE ON THIS PRODUCT IS LIMITED IN DURATION TO THE DURATION OF THIS WARRANTY.

Some states do not allow the exclusion or limitation of incidental or consequential damages, or allow limitations on how long an implied warranty lasts, so the above limitations or exclusions may not apply to you. This Limited Warranty gives you specific legal rights and you may have other rights which vary from state to state.

## Power sources

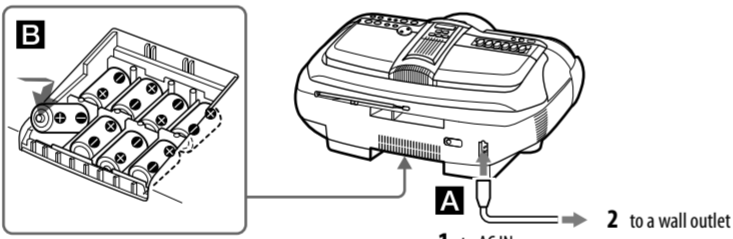

Connect the AC power cord **A** or insert eight R20 (size D) batteries (not supplied) into the battery compartment **B**.

### Notes

- Replace the batteries when the OPR/BATT indicator [17] dims or when the unit stops operating. Replace all the batteries with new ones. Before you replace the batteries, be sure to take out the CD from the unit.
- To use the unit on batteries, disconnect the AC power cord from the unit.
- When you operate the unit on batteries, you cannot turn on the unit using the remote.

### Preparing the remote

Insert two R6 (size AA) batteries (not supplied).

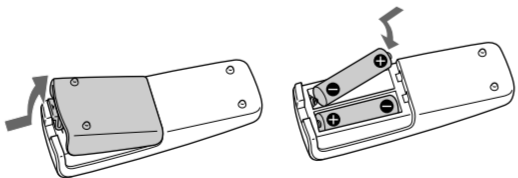

### Replacing batteries

With normal use, the batteries should last for about six months. When the remote no longer operates the unit, replace all the batteries with new ones.

## Other Operations

### Using the display

You can check information about the CD using the display.

#### Checking the information of an audio CD

**To check the total track number and playing time of the CD**

Press **■** **[8]** while the CD is stopped, and you can check them in the display.

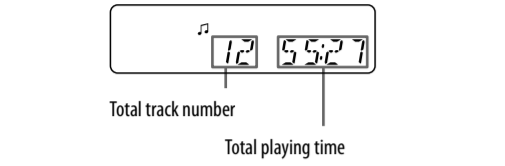

#### Checking the information of an MP3 disc

**To check the total folder number and total file number on the CD**

Press **■** **[8]** while the CD is stopped, and you can check them in the display.

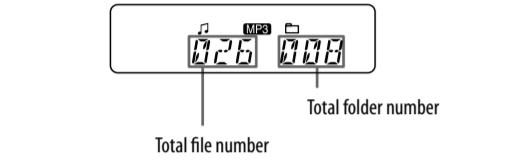

#### To check file information

Press DSPL/ENT **[19]** on the unit while playing an MP3 disc. The display changes as follows:

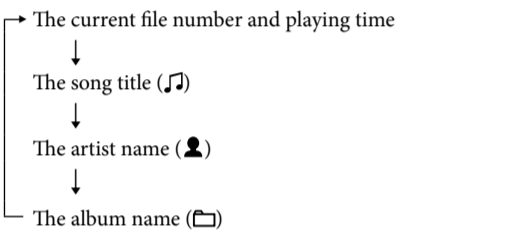

## Playing tracks/MP3 files repeatedly

#### (Repeat Play)

You can play tracks/MP3 files repeatedly in normal, Shuffle or Program play modes.

- Press **■** **[8]**. “CD” appears in the display.
- Proceed as follows.

To repeat	Do this
A single track/MP3 file	<ol style="list-style-type: none"><li>Press REPEAT <b>[13]</b> until “<b>☞</b> 1” appears.</li> <li>Press <b>◀◀</b> or <b>▶▶</b> <b>[7]</b> to select the track/MP3 file that you want to repeat.</li> <li>Press <b>▶▶</b> <b>[8]</b> on the unit.</li></ol>
All tracks/MP3 files on the CD	<ol style="list-style-type: none"><li>Press REPEAT <b>[13]</b> until “<b>☞</b>” appears.</li> <li>Press <b>▶▶</b> <b>[8]</b> on the unit.</li></ol>
A selected folder (MP3 disc only)	<ol style="list-style-type: none"><li>Press MODE <b>[14]</b> until “<b>☞</b>” appears, and then press REPEAT <b>[13]</b> until “<b>☞</b>” appears.</li> <li>Select the folder by pressing <b>+</b> or <b>−</b> <b>[6]</b>.</li> <li>Press <b>▶▶</b> <b>[8]</b> on the unit.</li></ol>
Tracks/MP3 files in random order	<ol style="list-style-type: none"><li>Select Shuffle Play (see “Playing tracks/MP3 files in random order”).</li> <li>Press REPEAT <b>[13]</b> until “SHUF” and “<b>☞</b>” appear.</li> <li>Press <b>▶▶</b> <b>[8]</b> on the unit.</li></ol>
Files in a selected folder in random order (MP3 disc only)	<ol style="list-style-type: none"><li>Start Folder Shuffle Play (see “Playing tracks/MP3 files in random order”).</li> <li>Press REPEAT <b>[13]</b> on the unit until “<b>☞</b>”, “SHUF” and “<b>☞</b>” appear.</li> <li>Press <b>▶▶</b> <b>[8]</b> on the unit.</li></ol>
Programed tracks/MP3 files	<ol style="list-style-type: none"><li>Program tracks/MP3 files (see “Creating your own program”).</li> <li>Press REPEAT <b>[13]</b> until “<b>☞</b>” and “PGM” appear.</li> <li>Press <b>▶▶</b> <b>[8]</b> on the unit.</li></ol>

#### On the remote

Use **▶** **[8]** instead of **▶▶** **[8]**.

#### To cancel Repeat Play

Press REPEAT **[13]** until “**☞**” disappears from the display.

### Playing tracks/MP3 files in random order (Shuffle Play)

You can play tracks/MP3 files in random order. When playing an MP3 disc, you can also play MP3 files in a selected folder in random order (Folder Shuffle Play).

- Press **■** **[8]**. “CD” appears in the display.
- Press MODE **[14]** until “SHUF” appears in the display. When you select Folder Shuffle Play (MP3 disc only), press MODE **[14]** on the unit until “**☞**” and “SHUF” appear in the display. Then press **☐** TUNE + or **−** **[6]** on the unit to select a folder you want.
- Press **▶▶** **[8]** on the unit to start Shuffle Play.

#### On the remote

Use **▶** **[8]** instead of **▶▶** **[8]**.

#### To cancel Shuffle Play

Stop playing first. Then press MODE **[14]** until “SHUF” disappears from the display.

#### Tips

- During Shuffle Play, you cannot select the previous track/MP3 file by pressing **◀◀** **[7]**.
- The resume function does not work during Shuffle Play.

### Creating your own program (Program Play)

You can arrange the playing order of up to 15 tracks/MP3 files on a CD.

- Press **■** **[8]**. “CD” appears in the display.
- Press MODE **[14]** until “PGM” flashes in the display.
- Press **◀◀** or **▶▶** **[7]** then press DSPL/ENT **[19]** on the unit (ENTER **[25]** on the remote) for the tracks/MP3 files you want to program in the order you want. For MP3 files, press **☐** TUNE + or **−** **[6]** first and then press **◀◀** or **▶▶** **[7]** and DSPL/ENT **[19]** (ENTER **[25]** on the remote).

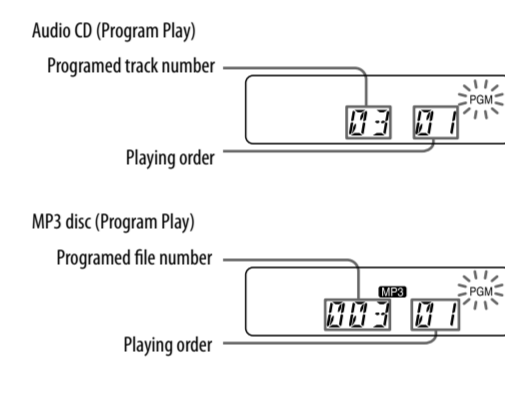

- Press **▶▶** **[8]** on the unit to start Program Play.

#### On the remote

Use **▶** **[8]** instead of **▶▶** **[8]**.

#### To cancel Program Play

Stop playing first. Then press MODE **[14]** until “PGM” disappears from the display.

#### To delete the last track or file of the program

Press CLEAR **[23]** on the remote while the unit is stopped.

#### To check the order of tracks/MP3 files before play

Press DSPL/ENT **[19]** on the unit.

Every time you press the button, the track number and the playing order appear.

#### To change the current program

Press **■** **[8]** once if the CD is stopped and twice if the CD is playing. The current program will be erased. Then create a new program following the programing procedure.

#### Tips

- If you try to program 16 tracks/MP3 files or more, “FULL” will appear in the display.
- You can play the same program again, since the program is saved until you open the CD compartment or turn off the power of the unit.
- You can record your own program. After you have created the program, insert a blank tape and press **●** **[2]** on the unit to start recording.
- The resume function does not work during Program Play.

### Presetting radio stations

You can store radio stations into the unit’s memory. You can preset up to 30 radio stations, 20 for FM and 10 for AM in any order.

- Press RADIO/BAND•AUTO PRESET **[5]** on the unit to select the band.
- Hold down RADIO/BAND•AUTO PRESET **[5]** on the unit for 2 seconds until “AUTO” flashes in the display.
- Press DSPL/ENT **[19]** on the unit. The stations are stored in memory from the lower frequencies to the higher ones.

#### If a station cannot be preset automatically

You need to preset a station with a weak signal manually.

- Press RADIO/BAND•AUTO PRESET **[5]** on the unit to select the band.
- Tune in a station you want.
- Hold down DSPL/ENT **[19]** on the unit for 2 seconds until the preset number flashes in the display.
- Press PRESET + or **−** **[7]** on the unit until the preset number you want for the station flashes in the display.
- Press DSPL/ENT **[19]** on the unit. The new station replaces the old one.

#### On the remote

- Press RADIO/BAND **[5]** until the band you want appears in the display.
- Tune in a station you want.
- Hold down ENTER **[25]** for 2 seconds until the preset number flashes in the display.
- Press PRESET + or **−** **[7]** until the preset number you want for the station flashes in the display.
- Press ENTER **[25]**.

**Tip**
The preset radio stations remain in memory even if you unplug the AC power cord or remove the batteries.

## Playing preset radio stations

- Press RADIO/BAND•AUTO PRESET **[5]** on the unit to select the band.
- Press PRESET + or **−** **[7]** on the unit to tune in the stored station.

#### On the remote

- Press RADIO/BAND **[5]**.
- Press PRESET + or **−** **[7]** to tune in the stored station.

## Falling asleep to music

- Play the music source you want.
- Press SLEEP **[18]** to display “SLEEP”.
- Press SLEEP **[18]** to select the minutes until the unit goes off automatically. Each time you press the button, the indication changes as follows: “AUTO” → “60MIN” → “30MIN” → “20MIN” → “10MIN” → “OFF”.
  - When you select “AUTO”, the CD or tape stops playing in 90 minutes at most and the unit goes off automatically. When you are listening to the radio, the radio goes off in 90 minutes.
  - If 4 seconds have passed after you pressed SLEEP **[18]**, the minutes in the display are entered. When the preset time has passed, the unit goes off automatically.

#### To cancel the sleep function

Press POWER **[1]** to turn off the power.

#### Note

When you are playing a tape using this function: If the tape length of one side is longer than the set time, the unit will not go off until the tape reaches the end.

## Connecting optional component

You can enjoy the sound from an optional component such as a portable digital music player through the speakers of this unit.

Be sure to turn off the power of each component before making any connections. For details, refer to the instruction manual of the component to be connected.

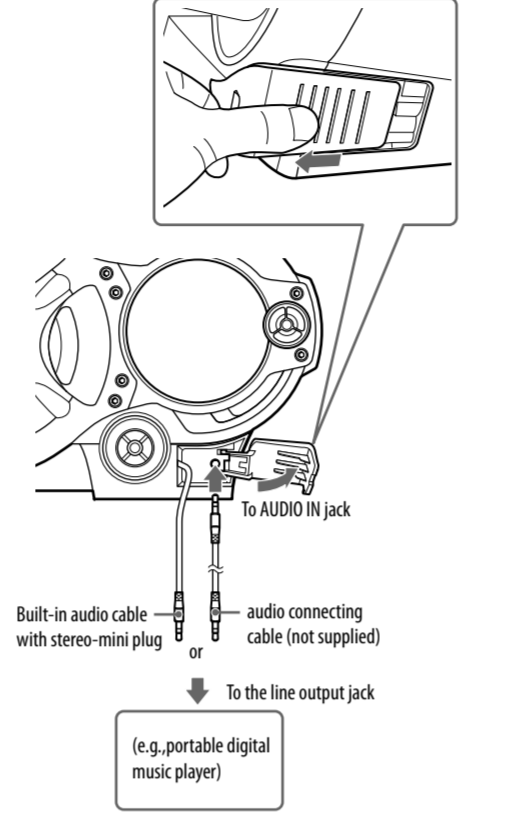

- Connect the built-in audio cable with stereo-mini plug **[12]** on the unit to the line output jack of the portable digital music player or other components\*.
- Turn the unit and the connected component on.
- Press AUDIO IN **[14]** on the unit and start playing sound on the connected component. The sound from the connected component is output from the speakers.

\* To connect the unit to a TV or VCR, use an extension cable (not supplied) with a stereo-mini jack on one end (for the built-in audio cable) and two phono plugs on the other end.

#### Recording the sound from the connected component

- Insert a blank tape.
- Press AUDIO IN **[14]** on the unit to display “AUDIO IN”. Recording starts.
- Press **●** **[2]** on the unit.
- Play the optional component connected to the unit.

#### Tip

Should the built-in audio cable **[12]** become damaged, you can use the AUDIO IN jack **[11]** to connect an optional component to the unit. Use an audio connecting cable (not supplied) with a stereo mini plug on one end (for the AUDIO IN jack **[11]**). Make sure the plug on the other end is suited to the jack on the optional component; for example, a stereo-mini plug for a portable digital music player, or two phono plugs for a TV or VCR.

#### Notes

- Do not pull forcibly on the built-in audio cable **[12]**. Doing so may cause the plug to rip off.
- Connect the built-in audio cable **[12]** or audio connecting cable (not supplied) securely to prevent any malfunction.
- It is not possible to listen to two components connected at the same time through the built-in audio cable **[12]** and the AUDIO IN jack **[11]** (using an optional audio connecting cable). Connect one component at a time.

## D-LIGHT SYNC OUT jack

Use the D-LIGHT SYNC controller to connect to this D-LIGHT SYNC OUT jack **[3]**. You need to connect the D-LIGHT SYNC controller to the lighting device\* (not supplied). The lighting device will react according to control signals transmitted by the D-LIGHT SYNC controller upon receiving music source from the system. For details on the use of D-LIGHT SYNC controller and lighting device, refer to the respective operating instructions supplied with the respective device.

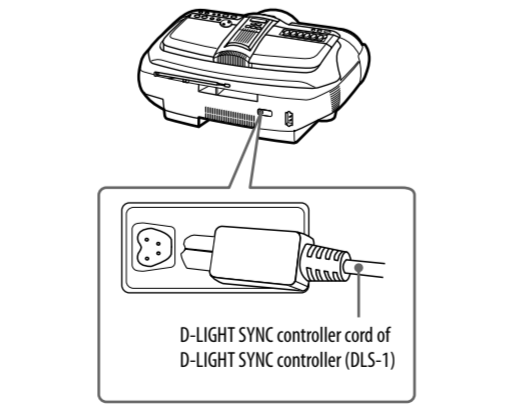

\* Refer to the D-LIGHT SYNC controller operating instruction for the recommended lighting device.

#### Note

The lighting effect may be different depending on the connected lighting device or the type of music being played back.

## Precautions

#### Discs that this unit CAN play

- Audio CD
- CD-R/CD-RW (CD-DA\*/MP3 files)
- CD-DA is the abbreviation for Compact Disc Digital Audio. It is a recording standard used for Audio CDs.

#### Discs that this unit CANNOT play

- CD-R/CD-RW other than those recorded in music CD format or MP3 format conforming to ISO9660 Level 1/Level 2 or Joliet
- CD-R/CD-RW of poor recording quality, CD-R/CD-RW that has scratches or are dirty, or CD-R/CD-RW recorded with an incompatible recording device
- CD-R/CD-RW which is finalized incorrectly

#### Notes on discs

- Before playing, clean the CD with a cleaning cloth. Wipe the CD from the center out. If there is a scratch, dirt or fingerprints on the CD, it may cause tracking error.

- Do not use solvents such as benzine, thinner, commercially available cleaners or anti-static spray intended for vinyl LPs.
- Do not expose the CD to direct sunlight or heat sources such as hot air ducts, nor leave it in a car parked in direct sunlight as there can be a considerable rise in temperature inside the car.
- Do not stick paper or sticker on the CD, nor scratch the surface of the CD.
- After playing, store the CD in its case.

#### On safety

- As the laser beam used in the CD player section is harmful to the eyes, do not attempt to disassemble the casing. Refer servicing to qualified personnel only.
- Should any solid object or liquid fall into the unit, unplug the unit, and have it checked by qualified personnel before operating it any further.
- Discs with non-standard shapes (e.g., heart, square, star) cannot be played on this unit. Attempting to do so may damage the unit. Do not use such discs.

#### On power sources

- For AC operation, use the supplied AC power cord; do not use any other type.
- The unit is not disconnected from the AC power source (mains) as long as it is connected to the wall outlet, even if the unit itself has been turned off.
- Unplug the unit from the wall outlet when it is not used for an extended period of time.
- When the batteries are not to be used, remove them to avoid damage that can be caused by battery leakage or corrosion.
- The nameplate indicating operating voltage, power consumption, etc. is located at the bottom.

#### On placement

- Do not leave the unit in a location near heat sources, in a place subject to direct sunlight, excessive dust or mechanical shock or in a car subject to the direct rays of the sun.
- Do not place the unit on an inclined or unstable place.
- Do not place anything within 10 mm of the side of the cabinet. The ventilation holes must be unobstructed for the unit to operate properly and prolong the life of its components.
- Since a strong magnet is used for the speakers, keep personal credit cards using magnetic coding or spring-wound watches away from the unit to prevent possible damage from the magnet.

#### On operation

- If the unit is brought directly from a cold to a warm location, or is placed in a very damp room, moisture may condense on the lens inside the CD player section. Should this occur, the unit will not operate properly. In this case, remove the CD and wait about an hour for the moisture to evaporate.
- If the unit has not been used for a long time, set it in the playback mode to warm it up for a few minutes before inserting a cassette.

#### Notes on cassettes

- Break off the cassette tab from side A or B to prevent accidental recording. If you want to reuse the tape for recording, cover the broken tab with adhesive tape.

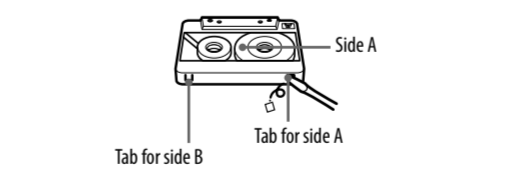

- The use of a cassette with more than 90 minutes of play time is not recommended except for long, continuous recording or playback.

#### Cleaning the cabinet

- Clean the cabinet, panel and controls with a soft cloth slightly moistened with a mild detergent solution. Do not use any type of abrasive pad, scouring powder, or solvent, such as alcohol or benzine.

If you have any questions or problems concerning your unit, please consult your nearest Sony dealer.

## Troubleshooting

### General

**The power is not on.**

- Connect the AC power cord to the wall outlet securely.
- Make sure the batteries are inserted correctly.
- Replace all the batteries with new ones if they are weak.
- You cannot turn on the unit with the remote when you operate the unit on batteries.

#### There is no audio.

- Make sure the function you want to use appears in the display window.
- Unplug the headphones when listening through speakers.

#### Noise is heard.

- Someone is using a portable telephone or other equipment that emits radio waves near the unit. → Move the portable telephone, etc., away from the unit.

#### The AUDIO IN lid has been detached.

→ Reattach the lid as shown in the illustration below. (Reattach in order of ① and ②.)

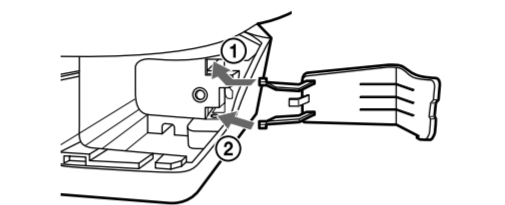

### CD/MP3 player

**The CD does not play or “NO DISC” is displayed even when a CD is in place.**

- Place the CD with the label surface up.
- Clean the CD.
- Take out the CD and leave the CD compartment open for about an hour to dry moisture condensation.
- The CD-R/CD-RW is blank.
- There is a problem with the quality of the CD-R/CD-RW, recording device or application software.
- Replace all the batteries with new ones if they are weak.

#### The sound drops out.

- Reduce the volume.
- Clean the CD, or replace it if the CD is badly damaged.
- Place the unit in a location free from vibration.
- Clean the lens with a commercially available blower.
- The sound may drop out or noise may be heard when using poor quality CD-R/CD-RW or if there is a problem with the recording device or application software.

#### Starting playback takes more time than usual.

- The following discs take a longer time to start playback.
  - a disc recorded with a complicated tree structure.
  - a disc that has not been finalized (a disc to which data can be added).
  - a disc that has many folders or non-MP3 files.

### Radio

#### Reception is poor.

- Reorient the antenna to improve FM reception.



- Reorient the unit itself to improve AM reception.

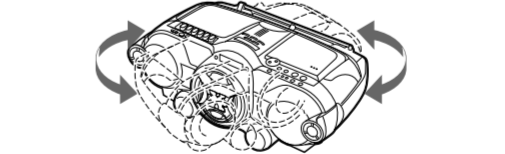

#### The audio is weak or has poor quality.

- Replace all the batteries with new ones if they are weak.
- Move the unit away from the TV.
- If you are using the remote while listening to AM radio, noise may be heard.

#### The picture of your TV becomes unstable.

- If you are listening to an FM program near the TV with an indoor antenna, move the unit away from the TV.