

**Europe, Middle East**

ENGLISH  
FRANÇAIS  
DEUTSCH  
NEDERLANDS  
ITALIANO  
ESPAÑOL  
PORTUGUÊS  
РУССКИЙ  
ΕΛΛΗΝΙΚΑ  
TÜRKÇE  
POLSKI  
العربية

**North America/  
Norteamérica**

ENGLISH  
FRANÇAIS  
ESPAÑOL

**Latin America/  
América Latina**

ENGLISH  
ESPAÑOL  
PORTUGUÊS

**Asia Pacific**

日本語  
简体中文  
繁體中文  
한국어  
ENGLISH



**THRUSTMASTER®**

**T300RS**  
GT Edition

# T300RS

## GT Edition

### User Manual

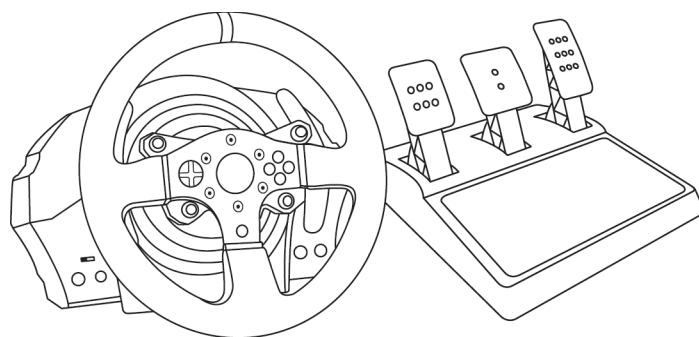

**WARNING:**

To ensure that your T300 racing wheel functions correctly with games, you may be required to install the game's automatic updates (available when your system is connected to the Internet).

ENGLISH

FRANÇAIS

DEUTSCH

NEDERLANDS

ITALIANO

ESPAÑOL

PORTUGUÊS

РУССКИЙ

ΕΛΛΗΝΙΚΑ

TÜRKÇE

POLSKI

## TECHNICAL FEATURES

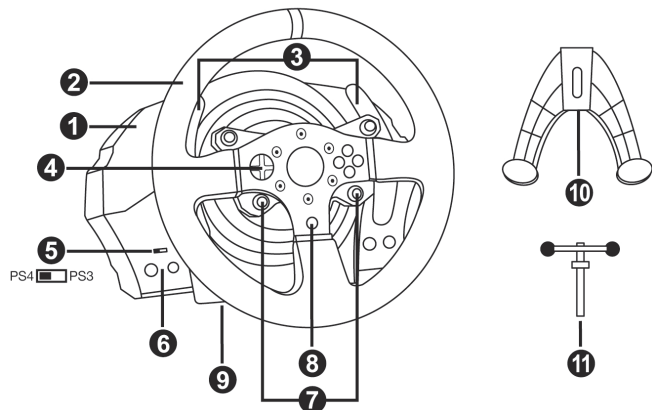

- |   |   |
|---|---|
| 1 T300 RS base                              | 7 SELECT/START buttons on PS3™ and SHARE/OPTIONS on PS4™          |
| 2 T300 GT wheel                             | 8 PS button   |
| 3 2 sequential paddle shifters (up & down)  | 9 Large threaded hole (for attachment system and fastening screw) |
| 4 Directional buttons                       | 10 Attachment system  |
| 5 Built-in USB sliding switch for PS4™/PS3™ | 11 Metal fastening screw  |
| 6 MODE button + red/green indicator light   |   |

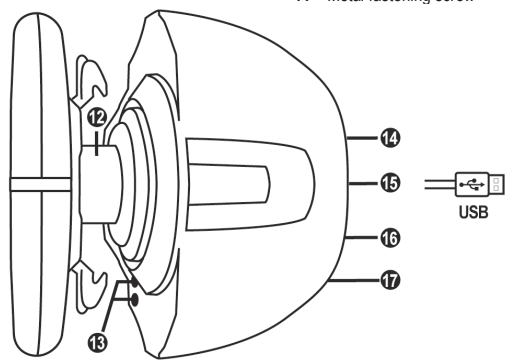

- |  |  |
|--|--|
| 12 Thrustmaster Quick Release  | 15 Racing wheel USB cable and connector                  |
| 13 L3/R3 buttons   | 16 Gearbox connector<br><i>(gearbox sold separately)</i> |
| 14 Power supply connector (type A or B)<br><i>(varies from one country to another)</i> | 17 Pedal set connector                                   |

## PLUGGING THE RACING WHEEL INTO AN ELECTRICAL OUTLET: PLEASE READ BEFORE PROCEEDING!

Your racing wheel's power supply varies according to the country where you purchased your device.  
The power supply can be:

### Internal, with:

- \* a power supply unit located directly inside the racing wheel's base, with a type A connector.
- \* a 220-240 V power supply cable.
- = compatible only with 220-240 V electrical power.

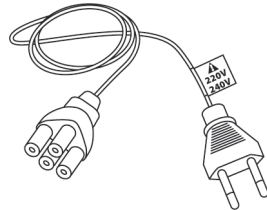

**Never connect the 220-240 V cable  
to a 100-130 V electrical outlet!!!  
Never connect this cable to a power adapter!!!**



### Internal, with:

- \* a power supply unit located directly inside the racing wheel's base, with a type A connector.
- \* a 100-125 V power supply cable.
- = compatible only with 100-125 V electrical power.

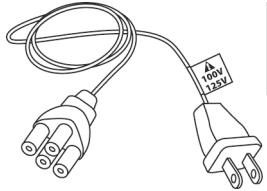

**Never connect the 100-125 V cable  
to a 220-240 V electrical outlet!!!  
Never connect this cable to a power adapter!!!**



**IMPORTANT: if you do not know which voltage is supplied in the area in which you are using  
your racing wheel, please ask your local electricity supplier.**

### External, with:

- \* an external power supply unit, with a type B connector.
- \* a power supply cable.
- = compatible with all electrical voltages, from 110-240 V.

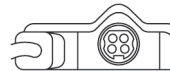
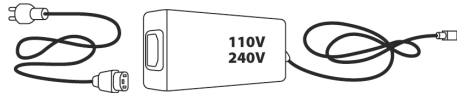

## WARNING

Before using this product, please read this manual carefully and save it for later reference.



### **Warning – Electrical shock**

- \* Keep the product in a dry location and do not expose it to dust or sunlight.
- \* Do not twist or pull on the connectors and cables.
- \* Do not spill any liquid on the product or its connectors.
- \* Do not short-circuit the product.
- \* Never dismantle the product; do not throw it onto a fire and do not expose it to high temperatures.
- \* Do not use a power supply cable other than the one provided with your racing wheel.
- \* Do not use the power supply cable if the cable or its connectors are damaged, split or broken.
- \* Make sure that the power supply cable is properly plugged into an electrical outlet, and properly connected to the connector at the rear of the racing wheel's base.
- \* Do not open up the racing wheel: there are no user-serviceable parts inside. Any repairs must be carried out by the manufacturer, its authorised representative or a qualified technician.
- \* Only use attachment systems/accessories specified by the manufacturer.
- \* If the racing wheel is operating abnormally (if it is emitting any abnormal sounds, heat or odours), stop using it immediately, unplug the power supply cable from the electrical outlet and disconnect the other cables.
- \* If you will not be using the racing wheel for an extended period of time, unplug its power supply cable from the electrical outlet.
- \* The power outlet shall be installed near the equipment and shall be easily accessible.



### **Air vents**

Make sure not to block any of the air vents on the racing wheel's base. For optimal ventilation, make sure to do the following:

- \* Position the wheel's base at least 10cm away from any wall surfaces.
- \* Do not place the base in any tight spaces.
- \* Do not cover the base.
- \* Do not let any dust build up on the air vents.



**For safety reasons, never use the pedal set with bare feet  
or while wearing only socks on your feet.  
THRUSTMASTER® DISCLAIMS ALL RESPONSIBILITY IN THE EVENT OF  
INJURY RESULTING FROM USE OF THE PEDAL SET WITHOUT SHOES.**



### **Warning – Injuries due to force feedback and repeated movements**

Playing with a force feedback racing wheel may cause muscle or joint pain. To avoid any problems:

- \* Avoid lengthy gaming periods.
- \* Take 10 to 15 minute breaks after each hour of play.
- \* If you feel any fatigue or pain in your hands, wrists, arms, feet or legs, stop playing and rest for a few hours before you start playing again.



**Warning – Injuries due to force feedback and repeated movements (continued)**

- \* If the symptoms or pain indicated persist when you start playing again, stop playing and consult your doctor.
- \* Keep out of children's reach.
- \* During gameplay, always leave both hands correctly positioned on the wheel without completely letting go.
- \* During gameplay, never place your hands or your fingers under the pedals or anywhere near the pedal set.
- \* During calibration and gameplay, never place your hand or your arm through the openings in the racing wheel.
- \* Make sure that the racing wheel's base is properly secured, as per this manual's instructions.

**HEAVY PRODUCT**



Product to be handled only by users  
16 years of age or older



Be careful not to drop the product on  
yourself or on anyone else!

**ALWAYS**

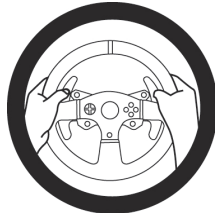

**NEVER**



**NEVER**



ENGLISH

FRANÇAIS

DEUTSCH

NEDERLANDS

ITALIANO

ESPAÑOL

PORTUGUÊS

РУССКИЙ

ΕΛΛΗΝΙΚΑ

TÜRKÇE

POLSKI

 **Warning – Pedal set pinch hazard when playing**

- \* Keep the pedal set out of children's reach.
- \* During gameplay, never place your fingers on or anywhere near the sides of the pedals.
- \* During gameplay, never place your fingers on or anywhere near the pedal's rear base.
- \* During gameplay, never place your fingers on or anywhere near the pedal's front base.



 **Warning – Pedal set pinch hazard when not playing**

- \* Store the pedal set in a safe place, and keep it out of children's reach.

## UPDATING YOUR RACING WHEEL'S FIRMWARE

The firmware included in your racing wheel's base can be updated to a more recent version featuring product enhancements.

To display the firmware version that your racing wheel is currently using and update it if required: on PC, visit <http://support.thrustmaster.com>. Click **Racing Wheels / T300 RS**, then select **Firmware** and follow the instructions describing the download and installation procedure.

**Important note:**

On PC, the USB sliding switch (5) on the racing wheel's base must always be set to the PS3™ position.

## INSTALLING THE WHEEL ON ITS BASE

Align the connector positions using the arrows:

**Base (1) connector:** Arrow pointing upwards

**Racing wheel (2) connector:** Arrow pointing upwards

Once the connectors are correctly positioned, simply rotate the Thrustmaster Quick Release (12) device's ring anticlockwise, while holding the racing wheel (2) in position.

Then, tighten the ring as much as you can: to do so, hold the ring in position and rotate the racing wheel clockwise.

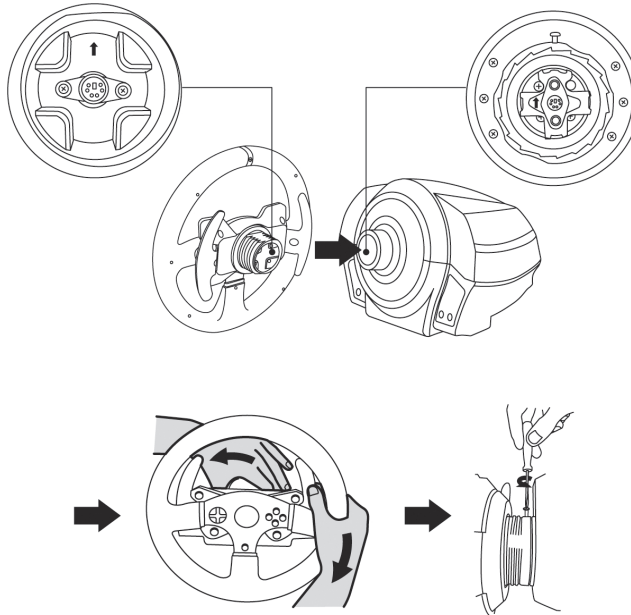

Once you have installed the wheel, rotate it 180° (when facing the wheel, the GT logo should be upside down) to access the small attachment screw located on the ring of the Thrustmaster Quick Release (12) device. Use a large Phillips screwdriver to tighten the small attachment screw (do not use excessive force), turning it clockwise.



**When using a Phillips screwdriver, ensure NOT to use excessive force when tightening the small attachment screw!  
Stop turning the screw as soon as you feel some resistance.**

## ATTACHING THE RACING WHEEL

### Attaching the racing wheel to a table or a desktop

1. Place the racing wheel on a table or any other horizontal, flat and stable surface.
2. Insert the fastening screw (11) in the attachment system (10), then tighten the device by turning the screw anticlockwise, so that it feeds into the large threaded hole (9) located beneath the racing wheel, until the wheel is perfectly stable.

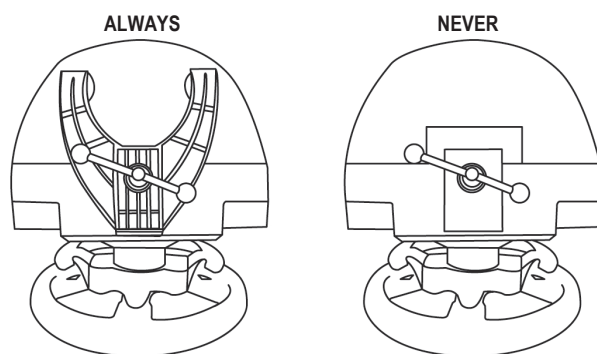

**WARNING:** Never tighten the screw alone, without the attachment system in place!  
(This could damage the racing wheel.)

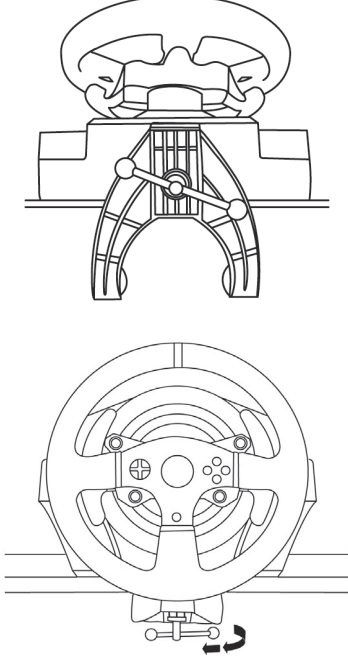
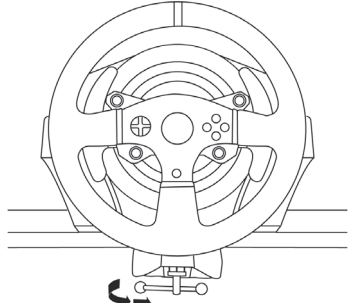
ATTACHMENT / REMOVAL	DIRECTION
<p><b>To tighten:</b> <i>Turn the screw anticlockwise</i></p>	
<p><b>To release:</b> <i>Turn the screw clockwise</i></p>	

### Attaching the racing wheel's base to a cockpit

1. Place the racing wheel's base on the cockpit shelf.
2. Drive two M6 screws (not included) through the cockpit shelf, then feed them into the two small screw threads located on the underside of the racing wheel.  
*Important: The length of the two M6 screws must not exceed the thickness of the shelf + 12 mm; longer screws could cause damage to internal components located in the racing wheel's base.*
3. If required, tighten the standard attachment system by inserting the fastening screw in the large threaded hole.

### PLAYSTATION®3 AND PLAYSTATION®4 MAPPING

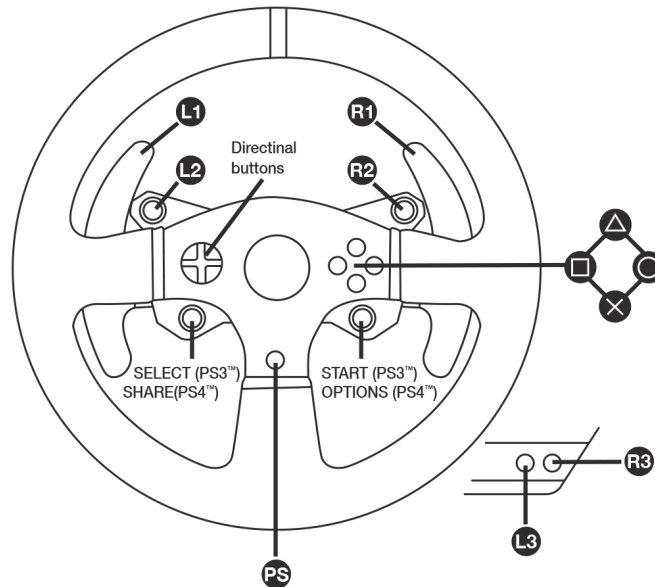

## SETTING UP THE RACING WHEEL FOR PLAYSTATION®3 OR PLAYSTATION®4

1. Connect the pedal set to the connector (17) located at the back of the racing wheel's base.
2. Connect the power supply cable to the connector (14) located at the back of the racing wheel's base.
3. Plug the power supply cable into an electrical outlet with the same voltage specifications.



*For more information about this, please refer to the **PLUGGING THE RACING WHEEL INTO AN ELECTRICAL OUTLET** section, on page 3 in this manual.*

4. Set the USB sliding switch (5) on the racing wheel's base to either the PS3™ or PS4™ position, depending on the system or the game you are using.
5. Connect the racing wheel's USB connector (15) to one of the system's USB ports.
6. Once your system is powered on, your racing wheel will calibrate itself automatically.
7. On PlayStation®4 (when the USB sliding switch is set to the PS4™ position): press the racing wheel's PS button (8) and sign in to your Sony Entertainment Network account, in order to be able to use the wheel.

*You are now ready to play!*

### Important notes:

- The USB sliding switch (5) on the racing wheel's base must always be set to the proper position (PS3™ or PS4™) before connecting the wheel's USB cable to the system. To change the sliding switch's position, disconnect the USB cable from the system and then change the position of the switch before reconnecting the USB cable to the system.
- On PlayStation®3, the USB sliding switch (5) must always be set to the PS3™ position:
  - \* The wheel is recognised in most games as a T500RS wheel.
  - \* The wheel is functional in compatible games and in system menus.
  - \* The "PS" function is functional on the wheel.
- On PlayStation®4, with the USB sliding switch (5) in the PS3™ position:
  - \* The wheel is recognised in most games as a T500RS wheel.
  - \* The wheel is functional in compatible games, but not in system menus.
  - \* The "SHARE" and "PS" functions are not functional on the wheel.
- On PlayStation®4, with the USB sliding switch (5) in the PS4™ position:
  - \* Don't forget to press the racing wheel's PS button (8) in order to be able to use the wheel.
  - \* The wheel is recognised in most games as a T300 RS wheel.
  - \* The wheel is functional in compatible games and in system menus.
  - \* The "SHARE" and "PS" functions are functional on the wheel.
- The list of PlayStation®3 and PlayStation®4 games compatible with the T300 RS (along with the required position for the USB sliding switch (5) according to the game being played) is available at:

<http://support.thrustmaster.com>  
(click Racing Wheels / T300 RS / Games settings).  
This list is updated regularly.

ENGLISH

FRANÇAIS

DEUTSCH

NETERLANDS

ITALIANO

ESPAÑOL

PORTUGUÊS

РУССКИЙ

ΕΛΛΗΝΙΚΑ

TÜRKÇE

POLSKI

## SETTING UP THE RACING WHEEL FOR PC\*

\* PC compatibility not tested nor endorsed by Sony Interactive Entertainment Europe.

For more information, visit <http://support.thrustmaster.com>.

### AUTOMATIC RACING WHEEL AND PEDAL SET CALIBRATION

The wheel automatically self-calibrates when you plug the racing wheel into an electrical outlet and connect the racing wheel's USB connector to the system.

During this phase, the racing wheel will rotate quickly towards the left and the right, covering a 1080 degree angle, before stopping at the centre.



**WARNING:**

**Never touch the racing wheel during the self-calibration phase!**  
*(This could result in improper calibration and/or personal injuries.)*

### AUTOMATIC CALIBRATION OF THE PEDAL SET

Never connect the pedal set to the racing wheel's base (or disconnect it from the base) when it is connected to the system or during gameplay (this could result in improper calibration).

Always connect the pedal set before connecting the racing wheel to the system.

Once the racing wheel's calibration is complete and the game has been started, the pedals are automatically calibrated after a few presses.



**WARNING:**

**Never press the pedals during the racing wheel's self-calibration phase or while a game is loading!**  
*(This could result in improper calibration.)*

**If your racing wheel and/or pedal set do not function correctly, or if they seem to be improperly calibrated:**

Power off your system and completely disconnect the racing wheel. Then reconnect all cables (including the power supply cable and the pedal set), and restart your system and your game.

### INTERNAL TEMPERATURE SENSOR

The wheel's cooling system is composed of a heat sink and a fan.

- A thermostat monitors the wheel's internal temperature.
- When you are using the wheel in a game:
  - The cooling fan starts up when the wheel has reached a certain temperature (after a few minutes of gameplay, depending on the strength of the Force Feedback effects used).
  - The power of the Force Feedback effects automatically decreases as soon as the wheel reaches a much higher temperature level (to protect the motor). The power of these effects automatically increases as soon as the temperature slightly decreases.
- When you're done playing: due to the motor's thermal inertia, the cooling fan continues to operate until the temperature drops below the fan's startup level. Your wheel has been designed in this way in order to facilitate cooling, and to protect the motor (this may take from 5 to 45 minutes, depending on the temperature reached while using the wheel in a game).

## MODE BUTTON AND INDICATOR LIGHT (6)

### MODE button for the pedal set

You can electronically swap the accelerator and clutch pedals.

To do so, simply press the MODE button (6) for 2 seconds.

The racing wheel's internal memory stores whether the pedals have been swapped around or not.

GAS AND CLUTCH PEDALS	Colour of the MODE indicator light (6)
NORMAL	RED
SWAPPED AROUND	GREEN

### Other information regarding the MODE button

To learn more about the MODE button and indicator light, please visit <http://support.thrustmaster.com>. Click **Racing Wheels / T300 RS**, and then select **Manual** or **FAQ**.

## HELP FILES AND FAQs (NOT INCLUDED IN THIS MANUAL)

Please visit <http://support.thrustmaster.com>. Click **Racing Wheels / T300 RS**, and then select **Manual** or **FAQ**.

ENGLISH

FRANÇAIS

DEUTSCH

NEDERLANDS

ITALIANO

ESPAÑOL

PORTUGUÊS

РУССКИЙ

ΕΛΛΗΝΙΚΑ

TÜRKÇE

POLSKI

## T3PA – GT EDITION PEDAL SET

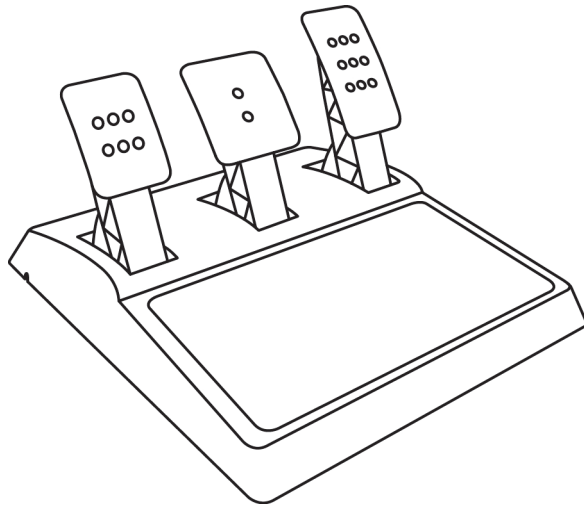

## TECHNICAL FEATURES

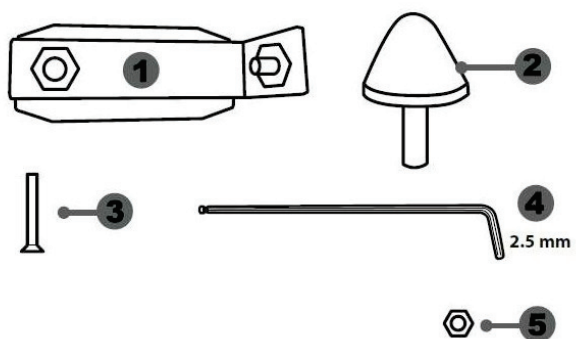

- 1 Metal support for conical stop  
*(not installed by default)*
- 2 Conical stop
- 3 Attachment screw for metal support
- 4 2.5 mm Allen key (included)
- 5 Position adjustment nut for conical stop

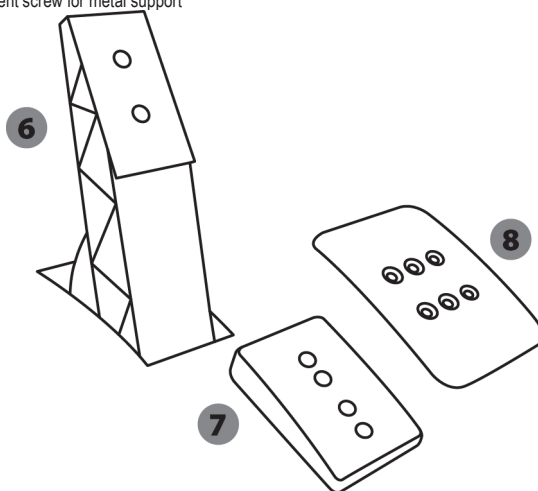

- 6 Pedal arm
- 7 Plastic head support

- 8 Metal pedal head

## WARNING

Before using this product, be sure to read these instructions carefully and save them for future reference.



For safety reasons, never use the pedal set with bare feet or while wearing only socks on your feet.

THRUSTMASTER® DISCLAIMS ALL RESPONSIBILITY IN THE EVENT OF INJURY RESULTING FROM USE OF THE PEDAL SET WITHOUT SHOES.



**Warning – Pedal set pinching hazard during gaming sessions**

- \* Keep the pedal set out of the reach of children.
- \* During gaming sessions, never place your fingers or thumbs on or near the sides of the pedals.
- \* During gaming sessions, never place your fingers or thumbs on or near the rear base of the pedals.
- \* During gaming sessions, never place your fingers or thumbs on or near the front base of the pedals.

NEVER



NEVER



NEVER

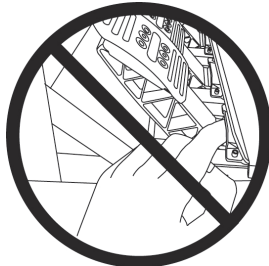

## AUTOMATIC CALIBRATION OF PEDALS



### **IMPORTANT:**

- Never connect or disconnect the pedal set from the base of the wheel when the wheel is connected to the PS3™ or PS4™ system, or during gaming sessions, to avoid calibration problems.
- = Always connect the pedal set to the wheel before connecting the wheel to the PS3™ or PS4™ system.
- Once the wheel has self-calibrated and the game has started, the pedals automatically calibrate themselves after being pressed a few times.
- Never press on the pedals when the wheel is self-calibrating or when your game is starting up, to avoid calibration problems.
- If the pedals are not functioning correctly or appear to be improperly calibrated, power off your system, completely disconnect your wheel, then reconnect all of the cables (including the power supply cable and the pedal set cable), power the system back on and restart your game.

## ATTACHING THE PEDAL SET TO A COCKPIT

- Attach the pedal set using the small screw threads located on the underside of the pedal set.
- Screw two M6 screws (not included) into the cockpit's pedal support plate and into the two small screw threads located on the underside of the pedal set.

**Important:** The length of the two M6 screws must not exceed the thickness of the cockpit's pedal support plate plus an additional 10 mm, to avoid damaging the pedal set's internal components.

ENGLISH

FRAANÇAIS

DEUTSCH

NEDERLANDS

ITALIANO

ESPAÑOL

PORTUGUÊS

РУССКИЙ

ΕΛΛΗΝΙΚΑ

TÜRKÇE

POLSKI

## ADJUSTING THE PEDAL SET

Each of the three pedals includes:

- A metal head (8) with multiple perforations (nine for the accelerator – two for the brake – six for the clutch).
- A plastic head support (7) (placed between the head and the arm) with four perforations.
- A pedal arm (6) with two perforations.

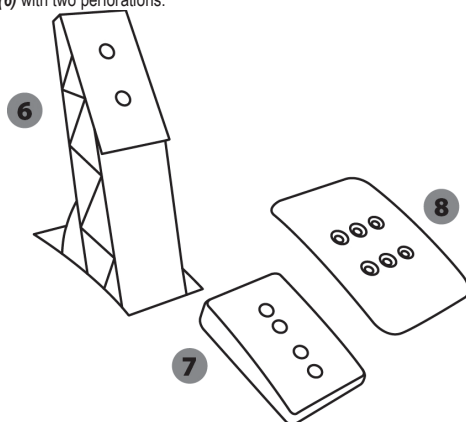

**ATTENTION:** To avoid any calibration problems, be sure to always disconnect your wheel's USB cable from the PS3™ or PS4™ system before making any adjustments to your pedal set.

### Adjusting the HEIGHT of the accelerator pedal

- Using the included 2.5 mm Allen key (4), unscrew the two screws holding the metal head (8) and its support (7) in place.
- Select your preferred height position, then replace and re-tighten the screws so that the metal head (8) and its support (7) are held firmly in place.

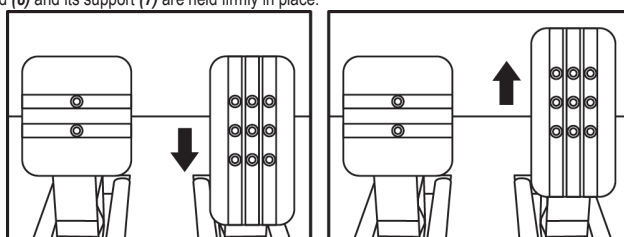

Low position (default)

High position

### Adjusting the SPACING

- Using the included 2.5 mm Allen key (4), unscrew the two screws holding the metal head (8) and its support (7) in place.
- Select your preferred position (to the left, centered, or to the right), then replace and re-tighten the screws so that the metal head (8) and its support (7) are held firmly in place.

Examples illustrating the clutch pedal:

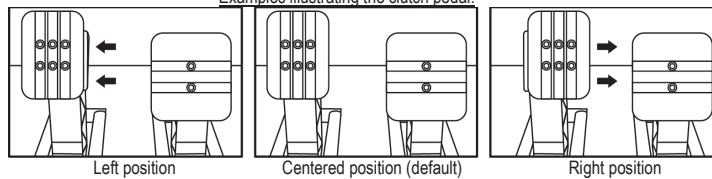

Number of possible spacing positions per pedal:

- Three for accelerator pedal
- Three for clutch pedal

### Adjusting the INCLINATION of the pedals

- Using the included 2.5 mm Allen key (4), unscrew the two screws holding the metal head (8) and its support (7) in place.
- Turn the plastic head support (7) 180°, then replace and re-tighten the screws so that the metal head (8) and its support (7) are held firmly in place.

Examples illustrating the accelerator pedal:

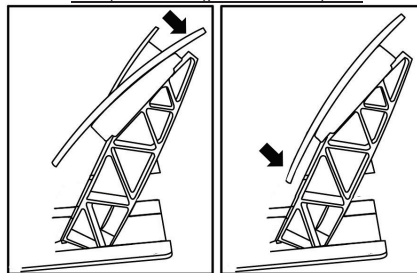

Less inclined position      More inclined position (default)

Number of possible inclination positions per pedal:

- Two for accelerator pedal
- Two for brake pedal
- Two for clutch pedal

### Installing the conical stop ("CONICAL RUBBER BRAKE" mod)

*This modification (or "mod") is not essential, and is not installed by default. This means that the brake pedal functions perfectly even if the mod is not installed.*

*This mod lets you experience a different feeling and resistance when braking. It's up to you whether or not to install it, depending on your own preferences.*

- Screw the conical stop (2) onto its metal support (1).
- Screw the position adjustment nut (5) onto the bottom (onto the conical stop's screw thread).

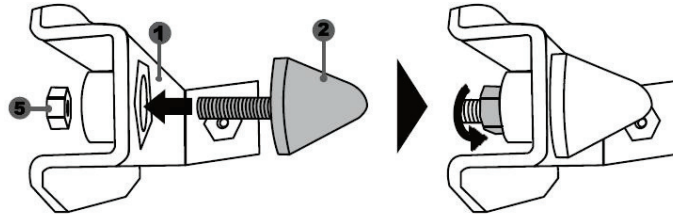

- Position the unit at the back of the brake pedal's arm.

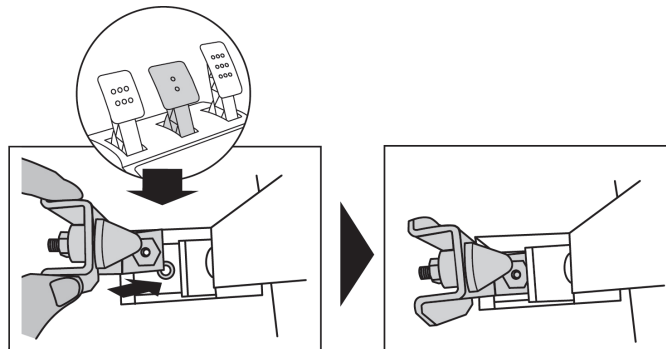

- Using the included 2.5 mm Allen key (4), attach the unit using the attachment screw (3) and the small central screw thread located on the underside of the pedal set.

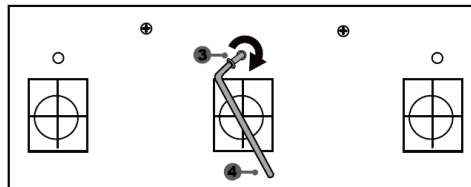
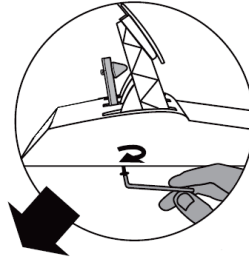

*The "CONICAL RUBBER BRAKE" mod is now installed!*

#### Adjusting the brake pedal's RANGE of travel and STRENGTH of resistance

By slightly unscrewing the nut (5), you can further strengthen the resistance of the brake pedal by moving the conical stop (2) closer to the back of the pedal's arm (if necessary, use a 14 mm wrench or pliers to re-tighten the nut and maintain the selected position). The closer the conical stop is positioned to the back of the pedal's arm, the greater the strength of resistance will be.

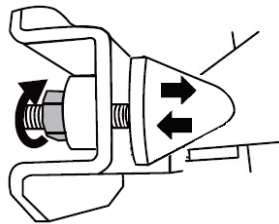

**Note:** When the conical stop is very close to the back of the brake pedal's arm, you may experience difficulties in reaching the maximum calibration value. Should that be the case:

- \* Slowly, press very hard on the brake pedal so as to reach the maximum value (if necessary, stand very briefly on the pedal – just for a second), then release the pressure; or else
- \* Move the conical stop a bit farther away from the back of the brake pedal's arm.

#### **CONSUMER WARRANTY INFORMATION**

Worldwide, Guillemot Corporation S.A., whose registered office is located at Place du Granier, B.P. 97143, 35571 Chantepie, France (hereinafter "Guillemot") warrants to the consumer that this Thrustmaster product shall be free from defects in materials and workmanship, for a warranty period which corresponds to the time limit to bring an action for conformity with respect to this product. In the countries of the European Union, this corresponds to a period of two (2) years from delivery of the Thrustmaster product. In other countries, the warranty period corresponds to the time limit to bring an action for conformity with respect to the Thrustmaster product according to applicable laws of the country in which the consumer was domiciled on the date of purchase of the Thrustmaster product (if no such action exists in the corresponding country, then the warranty period shall be one (1) year from the original date of purchase of the Thrustmaster product).

Should the product appear to be defective during the warranty period, immediately contact Technical Support, who will indicate the procedure to follow. If the defect is confirmed, the product must be returned to its place of purchase (or any other location indicated by Technical Support).

Within the context of this warranty, the consumer's defective product shall, at Technical Support's option, be either replaced or returned to working order. If, during the warranty period, the Thrustmaster product is subject to such reconditioning, any period of at least seven (7) days during which the product is out of use shall be added to the remaining warranty period (this period runs from the date of the consumer's request for intervention or from the date on which the product in question is made available for reconditioning, if the date on which the product is made available for reconditioning is subsequent to the date of the request for intervention). If permitted under applicable law, the full liability of Guillemot and its subsidiaries (including for consequential damages) is limited to the return to working order or the replacement of the Thrustmaster product. If permitted under applicable law, Guillemot disclaims all warranties of merchantability or fitness for a particular purpose.

This warranty shall not apply: (1) if the product has been modified, opened, altered, or has suffered damage as a result of inappropriate or abusive use, negligence, an accident, normal wear, or any other cause unrelated to a material or manufacturing defect (including, but not limited to, combining the Thrustmaster product with any unsuitable element, including in particular power supplies, rechargeable batteries, chargers, or any other elements not supplied by Guillemot for this product); (2) if the product has been used for any use other than home use, including for professional or commercial purposes (game rooms, training, competitions, for example); (3) in the event of failure to comply with the instructions provided by Technical Support; (4) to software, said software being subject to a specific warranty; (5) to consumables (elements to be replaced over the product's lifespan: disposable batteries, audio headset or headphone ear pads, for example); (6) to accessories (cables, cases, pouches, bags, wrist-straps, for example); (7) if the product was sold at public auction.

This warranty is nontransferable.

The consumer's legal rights with respect to laws applicable to the sale of consumer goods in his or her country are not affected by this warranty.

#### Additional warranty provisions

During the warranty period, Guillemot shall not provide, in principle, any spare parts, as Technical Support is the only party authorized to open and/or recondition any Thrustmaster product (with the exception of any reconditioning procedures which Technical Support may request that the consumer carry out, by way of written instructions – for example, due to the simplicity and the lack of confidentiality of the reconditioning process – and by providing the consumer with the required spare part(s), where applicable).

Given its innovation cycles and in order to protect its know-how and trade secrets, Guillemot shall not provide, in principle, any reconditioning notification or spare parts for any Thrustmaster product whose warranty period has expired.

#### Liability

If permitted under applicable law, Guillemot Corporation S.A. (hereinafter "Guillemot") and its subsidiaries disclaim all liability for any damages caused by one or more of the following: (1) the product has been modified, opened or altered; (2) failure to comply with assembly instructions; (3) inappropriate or abusive use, negligence, an accident (an impact, for example); (4) normal wear; (5) the use of the product for any use other than home use, including for professional or commercial purposes (game rooms, training, competitions, for example). If permitted under applicable law, Guillemot and its subsidiaries disclaim all liability for any damages unrelated to a material or manufacturing defect with respect to the product (including, but not limited to, any damages caused directly or indirectly by any software, or by combining the Thrustmaster product with any unsuitable element, including in particular power supplies, rechargeable batteries, chargers, or any other elements not supplied by Guillemot for this product).

