

# Multi Channel AV Receiver

Operating Instructions

STR-DH520

## WARNING

**To reduce the risk of fire or electric shock, do not expose this apparatus to rain or moisture.**

To reduce the risk of fire, do not cover the ventilation opening of the apparatus with newspapers, tablecloths, curtains, etc. Do not place the naked flame sources such as lighted candles on the apparatus.

Do not install the appliance in a confined space, such as a bookcase or built-in cabinet.

To reduce the risk of fire or electric shock, do not expose this apparatus to dripping or splashing, and do not place objects filled with liquids, such as vases, on the apparatus.

As the main plug is used to disconnect the unit from the mains, connect the unit to an easily accessible AC outlet. Should you notice an abnormality in the unit, disconnect the main plug from the AC outlet immediately.

Do not expose batteries or apparatus with battery-installed to excessive heat such as sunshine, fire or the like.

The unit is not disconnected from the mains as long as it is connected to the AC outlet, even if the unit itself has been turned off.

Excessive sound pressure from earphones and headphones can cause hearing loss.



This symbol is intended to alert the user to the presence of the Hot Surface that may be hot if it is touched during the normal operation.

## For customers in the United States

### Owner's Record

The model and serial numbers are located on the rear of the unit. Record these numbers in the space provided below. Refer to them whenever you call upon your Sony dealer regarding this product.

Model No. \_\_\_\_\_ Serial No. \_\_\_\_\_



This symbol is intended to alert the user to the presence of uninsulated "dangerous voltage" within the product's enclosure that may be of sufficient magnitude to constitute a risk of electric shock to persons.



This symbol is intended to alert the user to the presence of important operating and maintenance (servicing) instructions in the literature accompanying the appliance.

### Important Safety Instructions

- 1) Read these instructions.
- 2) Keep these instructions.
- 3) Heed all warnings.
- 4) Follow all instructions.
- 5) Do not use this apparatus near water.
- 6) Clean only with dry cloth.
- 7) Do not block any ventilation openings. Install in accordance with the manufacturer's instructions.
- 8) Do not install near any heat sources such as radiators, heat registers, stoves, or other apparatus (including amplifiers) that produce heat.
- 9) Do not defeat the safety purpose of the polarized or grounding-type plug. A polarized plug has two blades with one wider than the other. A grounding type plug has two blades and a third grounding prong. The wide blade or the third prong are provided for your safety. If the provided plug does not fit into your outlet, consult an electrician for replacement of the obsolete outlet.
- 10) Protect the power cord from being walked on or pinched particularly at plugs, convenience receptacles, and the point where they exit from the apparatus.
- 11) Only use attachments/accessories specified by the manufacturer.

- 12) Use only with the cart, stand, tripod, bracket, or table specified by the manufacturer, or sold with the apparatus. When a cart is used, use caution when moving the cart/apparatus combination to avoid injury from tip-over.



- 13) Unplug this apparatus during lightning storms or when unused for long periods of time.
- 14) Refer all servicing to qualified service personnel. Servicing is required when the apparatus has been damaged in any way, such as power-supply cord or plug is damaged, liquid has been spilled or objects have fallen into the apparatus, the apparatus has been exposed to rain or moisture, does not operate normally, or has been dropped.

**The following FCC statement applies only to the version of this model manufactured for sale in the U.S.A. Other versions may not comply with FCC technical regulations.**

**NOTE:**

This equipment has been tested and found to comply with the limits for a Class B digital device, pursuant to Part 15 of the FCC Rules. These limits are designed to provide reasonable protection against harmful interference in a residential installation.

This equipment generates, uses and can radiate radio frequency energy and, if not installed and used in accordance with the instructions, may cause harmful interference to radio communications. However, there is no guarantee that interference will not occur in a particular installation. If this equipment does cause harmful interference to radio or television reception, which can be determined by turning the equipment off and on, the user is encouraged to try to correct the interference by one or more of the following measures:

- Reorient or relocate the receiving antenna.
- Increase the separation between the equipment and receiver.
- Connect the equipment into an outlet on a circuit different from that to which the receiver is connected.
- Consult the dealer or an experienced radio/TV technician for help.

**CAUTION**

You are cautioned that any changes or modifications not expressly approved in this manual could void your authority to operate this equipment.

To reduce the risk of electric shock, the speaker cord should be connected to the apparatus and the speakers in accordance with the following instructions.

- 1) Disconnect the AC power cord from the MAINS.
- 2) Strip 10 to 15 mm of the wire insulation of the speaker cord.
- 3) Connect the speaker cord to the apparatus and the speakers carefully so as not to touch the core of speaker cord by hand. Also disconnect the AC power cord from the MAINS before disconnecting the speaker cord from the apparatus and the speakers.

**For customers in Europe**



**Disposal of Old Electrical & Electronic Equipment (Applicable in the European Union and other European countries with separate collection systems)**

This symbol on the product or on its packaging indicates that this product shall not be treated as household waste. Instead it shall be handed over to the applicable collection point for the recycling of electrical and electronic equipment. By ensuring this product is disposed of correctly, you will help prevent potential negative consequences for the environment and human health, which could otherwise be caused by inappropriate waste handling of this product. The recycling of materials will help to conserve natural resources. For more detailed information about recycling of this product, please contact your local Civic Office, your household waste disposal service or the shop where you purchased the product.



### **Disposal of waste batteries (applicable in the European Union and other European countries with separate collection systems)**

This symbol on the battery or on the packaging indicates that the battery provided with this product shall not be treated as household waste.

On certain batteries this symbol might be used in combination with a chemical symbol. The chemical symbols for mercury (Hg) or lead (Pb) are added if the battery contains more than 0.0005% mercury or 0.004% lead.

By ensuring these batteries are disposed of correctly, you will help prevent potentially negative consequences for the environment and human health which could otherwise be caused by inappropriate waste handling of the battery. The recycling of the materials will help to conserve natural resources.

In case of products that for safety, performance or data integrity reasons require a permanent connection with an incorporated battery, this battery should be replaced by qualified service staff only.

To ensure that the battery will be treated properly, hand over the product at end-of-life to the applicable collection point for the recycling of electrical and electronic equipment.

For all other batteries, please view the section on how to remove the battery from the product safely. Hand the battery over to the applicable collection point for the recycling of waste batteries.

For more detailed information about recycling of this product or battery, please contact your local Civic Office, your household waste disposal service or the shop where you purchased the product.

### **Notice for customers: The following information is only applicable to equipment sold in countries applying EU Directives.**

The manufacturer of this product is Sony Corporation, 1-7-1 Konan Minato-ku Tokyo, 108-0075 Japan. The Authorized Representative for EMC and product safety is Sony Deutschland GmbH, Hedelfinger Strasse 61, 70327 Stuttgart, Germany. For any service or guarantee matters please refer to the addresses given in separate service or guarantee documents.

### **For customers in Australia**



### **Disposal of Old Electrical & Electronic Equipment (Applicable in the European Union and other European countries with separate collection systems)**

## About This Manual

- The instructions in this manual are for model STR-DH520. The model number is located at the lower right front panel of the receiver. The illustrations used in this manual are of Europe model and they may be different from your model. Any differences in operation are marked in the manual as “Europe model only”.
- The instructions in this manual describe the operation of the receiver with the supplied remote control. You can also use the control buttons on the receiver if they have the same or similar names as those on the remote control.

## On Copyrights

This receiver incorporates Dolby\* Digital and Pro Logic Surround and the DTS\*\* Digital Surround System.

\* Manufactured under license from Dolby Laboratories. Dolby, Pro Logic, and the double-D symbol are trademarks of Dolby Laboratories.

\*\* Manufactured under license under U.S. Patent #'s: 5,451,942; 5,956,674; 5,974,380; 5,978,762; 6,226,616; 6,487,535; 7,212,872; 7,333,929; 7,392,195; 7,272,567 & other U.S. and worldwide patents issued & pending. DTS and the Symbol are registered trademarks, & DTS-HD, DTS-HD Master Audio, and the DTS logos are trademarks of DTS, Inc. Product includes software. © DTS, Inc. All Rights Reserved.

This receiver incorporates High-Definition Multimedia Interface (HDMI™) technology. HDMI, the HDMI Logo, and High-Definition Multimedia Interface are trademarks or registered trademarks of HDMI Licensing LLC in the United States and other countries.

“x.v.Color (x.v.Colour)” and “x.v.Color (x.v.Colour)” logo are trademarks of Sony Corporation.

“BRAVIA” is a trademark of Sony Corporation.

“PlayStation” is a registered trademark of Sony Computer Entertainment Inc.

---

# Table of Contents

About This Manual.....	4
Supplied accessories.....	6
Description and location of parts.....	7
Getting started .....	16

---

## Connections

1: Installing the speakers .....	17
2: Connecting the speakers.....	19
3: Connecting the TV .....	21
4a: Connecting the video equipment.....	22
4b: Connecting the audio equipment.....	28
5: Connecting the antennas (aerials).....	28
6: Connecting the AC power cord (mains lead) .....	29

---

## Preparing the Receiver

Initializing the receiver.....	29
Selecting the speaker pattern.....	30
Using AUTO CALIBRATION.....	31
(Europe, Australia and Taiwan models only)	
Adjusting the speaker levels (TEST TONE) .....	35

---

## Basic Operations

Playback .....	36
Viewing information on the display panel .....	37
Recording using the receiver .....	38

---

## Tuner Operations

Listening to FM/AM radio .....	39
Presetting FM/AM radio stations .....	41
Receiving RDS broadcasts .....	42
(Europe, Australia and Taiwan models only)	

---

---

## Enjoying Surround Sound

Selecting the sound field.....	43
Resetting sound fields to the default settings .....	47

---

## “BRAVIA” Sync Features

What is “BRAVIA” Sync?.....	47
Preparing for the “BRAVIA” Sync.....	48
Playing back equipment with one-touch operation (One-Touch Play).....	49
Enjoying the TV sound from the speakers connected to the receiver (System Audio Control).....	49
Turning off the receiver with the TV (System Power-Off) .....	50
Enjoying movies with the optimum sound field (Theater/Theatre Mode Sync).....	50
Enjoying optimum sound field for the selected scene (Scene Select).....	50

---

## Advanced Operations

Switching between digital and analog audio (INPUT MODE) .....	51
Using the sound/images from other inputs.....	51
Using the setting menu .....	53

---

## Using the Remote Control

Reassigning the input button.....	61
Resetting the input buttons.....	62

---

## Additional Information

Precautions.....	63
Troubleshooting .....	64
Specifications.....	69
Index .....	71

---

## Supplied accessories

- Operating Instructions (this manual)
- Quick Setup Guide
- FM wire antenna (aerial) (1)



- AM loop antenna (aerial) (1)



- Remote control (1)
  - RM-AAU104 (USA and Canada models only)
  - RM-AAU105 (Other models)

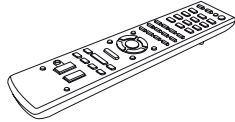

- R6 (size AA) batteries (2)



- Optimizer microphone (ECM-AC2) (Europe, Australia and Taiwan models only) (1)



## Inserting batteries into the remote control

Insert two R6 (size AA) batteries (supplied) by matching  $\oplus$  and  $\ominus$  on the batteries to the diagram inside the battery compartment of the remote control.

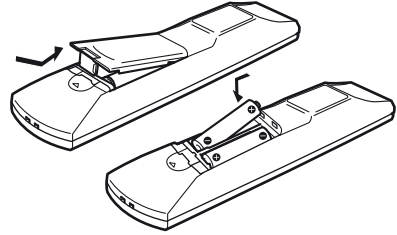

### Notes

- Do not leave the remote control in an extremely hot or humid place.
- Do not use a new battery with old ones.
- Do not mix manganese batteries and other kinds of batteries.
- Do not expose the remote control sensor to direct sunlight or lighting apparatuses. Doing so may cause a malfunction.
- If you do not intend to use the remote control for an extended period of time, remove the batteries to avoid possible damage from battery leakage and corrosion.
- When you replace or remove the batteries, the remote control buttons may be reset to their default settings. If this happens, reassign the input buttons (page 61).
- When the receiver no longer responds to the remote control, replace all the batteries with new ones.

# Description and location of parts

## Front panel

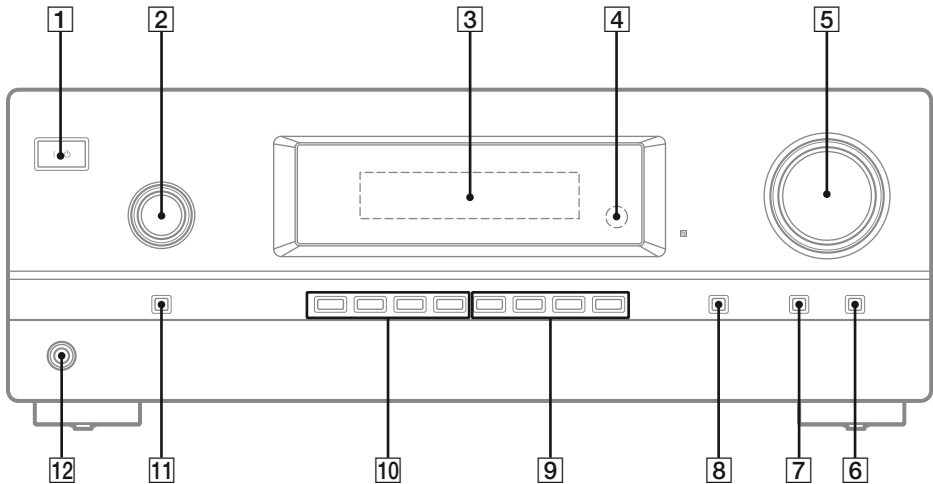

- 1** I/⏻ (on/standby) (page 29, 40, 47)
- 2** INPUT SELECTOR (page 36 - 39, 41, 51)
- 3** Display panel (page 8)
- 4** Remote control sensor  
Receives signals from remote control.
- 5** MASTER VOLUME (page 36, 37)
- 6** MUTING (page 37)
- 7** DIMMER  
Adjusts the brightness of the display panel in 3 levels.
- 8** DISPLAY (page 38)
- 9** 2CH/A.DIRECT, A.F.D., MOVIE/HD-D.C.S., MUSIC (page 43)
- 10** TUNING MODE, TUNING +/-, MEMORY/ ENTER (page 39)
- 11** INPUT MODE (page 51)
- 12** PHONES jack (page 64)

# Indicators on the display panel

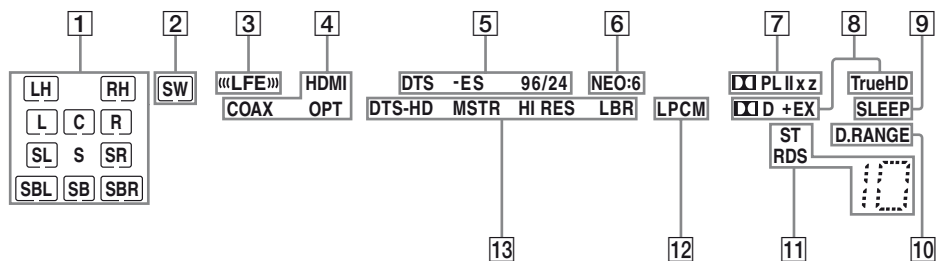

## 1 Playback channel indicators

The letters (L, C, R, etc.) indicate the channels being played back. Based on the speaker settings, the box around the letter(s) vary to show how the receiver downmixes the source sound.

<b>LH</b>	Front Left High
<b>RH</b>	Front Right High
<b>L</b>	Front Left
<b>R</b>	Front Right
<b>C</b>	Center (monaural)
<b>SL</b>	Surround Left
<b>SR</b>	Surround Right
<b>S</b>	Surround (monaural or the surround equipment obtained by Pro Logic processing)
<b>SBL</b>	Surround Back Left
<b>SBR</b>	Surround Back Right
<b>SB</b>	Surround Back (the surround back equipment obtained by 6.1 channel decoding)

**Example:**  
Speaker pattern: 3/0.1  
Recording format: 3/2.1  
Sound Field: A.F.D. AUTO



## 2 SW

Lights up when the audio signal is output from the SUBWOOFER jack.

## 3 «LFE»

Lights up when the disc being played back contains an LFE (Low Frequency Effect) channel and the LFE channel signal is actually being reproduced.

## 4 Input indicator

Lights up to indicate the current input.

### HDMI

- The INPUT MODE is set to “AUTO”, and when the receiver recognizes the equipment connected via an HDMI IN jack (page 51).
- The TV input detected Audio Return Channel (ARC) signals.

### COAX

The INPUT MODE is set to “AUTO” or “COAX”, and when the source signal is a digital signal through the COAXIAL jack (page 51).

### OPT

The INPUT MODE is set to “AUTO” or “OPT”, and when the source signal is a digital signal through the OPTICAL jack (page 51).

## 5 DTS(-ES) indicator

Lights up the respective indicator when the receiver is decoding the corresponding DTS format signals.

<b>DTS</b>	DTS
<b>DTS-ES</b>	DTS-ES
<b>DTS 96/24</b>	DTS 96 kHz/24 bit

### Note





When playing a DTS format disc, make sure that you have completed the digital connections and that INPUT MODE is not set to “ANALOG” (page 51).

## 6 NEO:6

Lights up when DTS Neo:6 Cinema/Music decoder is activated (page 44).

### 7 **Dolby Pro Logic indicator**

Lights up the respective indicator when the receiver performs Dolby Pro Logic processing. This matrix surround decoding technology can enhance input signals.





 <b>PL</b>	Dolby Pro Logic
 <b>PL II</b>	Dolby Pro Logic II
 <b>PL IIx</b>	Dolby Pro Logic IIx
 <b>PL IIz</b>	Dolby Pro Logic IIz

#### **Note**

These indicators may not light up depending on the speaker pattern setting.

### 8 **Dolby Digital Surround indicator**

Lights up the respective indicator when the receiver is decoding the corresponding Dolby Digital format signals.

 <b>D</b>	Dolby Digital
 <b>D EX</b>	Dolby Digital Surround EX
 <b>D+</b>	Dolby Digital Plus
 <b>TrueHD</b>	Dolby TrueHD

#### **Note**

When playing a Dolby Digital format disc, make sure that you have completed the digital connections and that INPUT MODE is not set to "ANALOG" (page 51).

### 9 **SLEEP**

Lights up when the Sleep Timer is activated (page 13).

### 10 **D.RANGE**

Lights up when dynamic range compression is activated (page 57).

### 11 **Tuning indicators**

Lights up when the receiver tunes to a radio station.

#### **ST**

Stereo broadcast

#### **RDS (Europe, Australia and Taiwan models only)**

Tuned to a station with RDS services.



Preset station number (The number will change according to the preset station you select.)

### 12 **LPCM**

Lights up when the receiver is decoding the Linear PCM signals.

### 13 **DTS-HD indicator**

Lights up the respective indicator when the receiver is decoding the corresponding DTS-HD format signals.

#### **DTS-HD MSTR**

DTS-HD Master Audio

#### **DTS-HD HI RES**

DTS-HD High Resolution Audio

#### **DTS-HD LBR**

DTS-HD Low Bit Rate Audio

# Rear panel

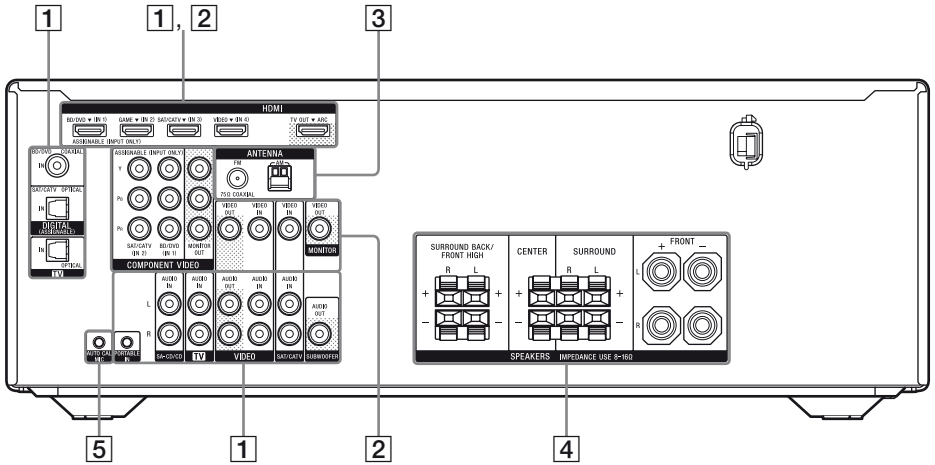

## 1 Audio signal section

**DIGITAL INPUT/OUTPUT jacks (page 21, 24, 26)**

 HDMI IN/OUT

 OPTICAL IN

 COAXIAL IN

**ANALOG INPUT/OUTPUT jacks (page 21, 26, 28)**

 White (L)

AUDIO IN/OUT

 Red (R)

AUDIO OUT

 Black

 PORTABLE IN

## 2 Video signal section\*

The image quality depends on the connecting jack.

**DIGITAL INPUT/OUTPUT jacks (page 21, 24, 25, 26, 27)**

 HDMI IN/OUT

**COMPONENT VIDEO INPUT/OUTPUT jacks (page 21, 24, 26)**

 Green (Y)

 Blue (P<sub>B</sub>)

Y, P<sub>B</sub>, P<sub>R</sub> IN/OUT

 Red (P<sub>R</sub>)

**COMPOSITE VIDEO INPUT/OUTPUT jacks (page 21, 26, 27)**

 Yellow VIDEO IN/OUT

\* You must connect the HDMI TV OUT or MONITOR OUT jack to your TV to watch the selected input image (page 21).

High quality image



### 3 ANTENNA section (page 28)

 FM ANTENNA jack

 AM ANTENNA terminals

### 4 SPEAKERS section (page 19)

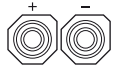

### 5 AUTO CALIBRATION section (Europe, Australia and Taiwan models only) (page 31)

 AUTO CAL MIC jack

## Remote control

Use the supplied remote control to operate this receiver and other equipment. The remote control is assigned to operate Sony audio/video equipment. You can reassign the input button to match the equipment connected to your receiver (page 61).

- **RM-AAU104 (USA and Canada models only)**
- **RM-AAU105 (Other models)**

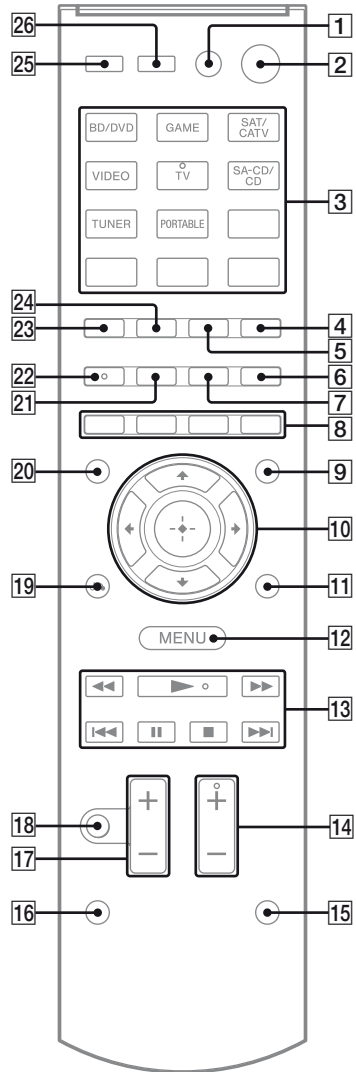

## To use the buttons printed in pink

Hold down SHIFT (15), then press the button printed in pink that you want to use.

Example: Hold down SHIFT (15), then press ENT/MEM (3).

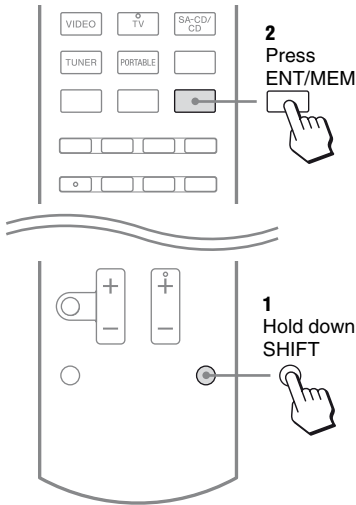

## To control the receiver

### 2 I/O\* (on/standby)

Turns the receiver on or sets it to standby mode.

#### Saving the power in standby mode

When "CTRL.HDMI" is set to "CTRL OFF" (page 56).

### 3 Input buttons\*\*

Selects the equipment you want to use. When you press any of the input buttons, the receiver turns on. The buttons are assigned to control Sony equipment.

#### Numeric buttons\*\*

Hold down SHIFT (15), then press numeric buttons to preset or tune to the preset stations.

#### ENT/MEM

Hold down SHIFT (15), then press ENT/MEM to store a station during tuner operation.

### 4 DIMMER

Adjusts the brightness of the display panel in 3 levels.

### 5 INPUT MODE

Selects the input mode when the same equipment is connected to both digital and analog jacks.

### 6 DISPLAY

Views information on the display panel.

### 9 AMP MENU

Displays the menu to operate the receiver.

### 10

Press /// to select the settings, then press to enter/confirm the selection.

### 13 TUNING +/-

Scans a station.

#### PRESET +/-

Selects preset stations.

#### D.TUNING

Enters direct tuning mode.

### 14 SOUND FIELD +\*\*/-

Selects a sound field.

### 15 SHIFT

Changes the remote control button function to activate the buttons printed in pink (page 12).

### 17 MASTER VOL +/- or

Adjust the volume level of all speakers at the same time.

### 18 MUTING or

Turns off the sound temporarily.

Press the button again to restore the sound.

### 19 RETURN/EXIT

Returns to the previous menu.

### 23 AUTO VOL

Adjusts the volume automatically depending on the input signal or content from the connected equipment (ADVANCED AUTO VOLUME function).

This function is useful, for example, when the sound of a commercial is louder than the TV programs.

#### Notes

- Be sure to reduce the volume level before you turn off this function.
- As this function is available only when Dolby Digital, DTS or Linear PCM signals are input, the sound may suddenly increase when you switch to other formats.
- This function does not work in the following cases.
  - Linear PCM signals with a sampling frequency of more than 48 kHz are being received.
  - Dolby Digital Plus, Dolby TrueHD, DTS 96/24, DTS-HD Master Audio, or DTS-HD High Resolution Audio signals are being received.

## AUTO CAL

Hold down SHIFT (15), then press AUTO CAL to activate the Auto Calibration function (page 31).

## 24 NIGHT MODE

Allows you to retain a theater like environment at low volume levels.

When watching a movie late at night, you will be able to hear the dialog clearly even at a low volume level. This function can be used with other sound fields.

Press the button again to turn off this function.

### Note

This function does not work when "A. DIRECT" is selected.

### Tips

- You can also set the NIGHT MODE by using the "NIGHT M." in AUDIO menu.
- While the NIGHT MODE is turned on, the bass, treble, and effect levels increase, and "D. RANGE" is automatically set to "COMP. MAX".

## 25 SLEEP

Sets the receiver to turn off automatically at a specified time.

Each time you press this button, the display changes cyclically as follows.

0-30-00 → 1-00-00 → 1-30-00 → 2-00-00 → OFF

When Sleep Timer is being used, "SLEEP" indicator lights up in the display panel.

### Tip

To check the remaining time before the receiver turns off, press SLEEP. The remaining time appears on the display panel. If you press SLEEP again, the Sleep Timer will be canceled.

\* If you press AV I/⏻ (1) and I/⏻ (2) simultaneously, the receiver and connected equipment will turn off (SYSTEM STANDBY). The function of the AV I/⏻ (1) changes automatically each time you press the input buttons (3).

\*\* The 5/TV, AUDIO/⏻, ► and TV CH +/ SOUND FIELD +/PROG +/⏻ buttons have tactile dots. Use the tactile dots as references when operating the receiver.

## To control a Sony TV

Hold down TV (16), then press the button printed in yellow to select the function you want.

Example: Hold down TV (16), then press TV CH + or PROG + (14).

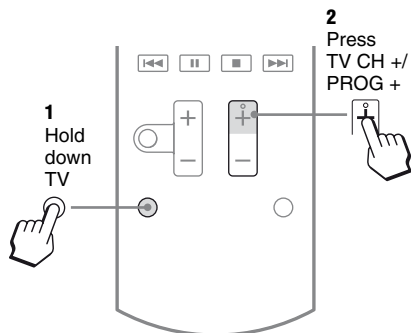

## 1 TV I/⏻ (on/standby)

Turns the TV on or off.

## 3 Numeric buttons\*\*

Selects the TV channels.

### ENT/MEM

Enters the selections.

### ⏮ (Previous channel)

Returns to the previous channel watched (for more than five seconds).

### CLEAR

Use with the numeric buttons to select the channel numbers of the Digital CATV terminal. For example, to select 2.1, press 2, CLEAR, and 1.

### ≡ (Text)

Displays text information.

## 6 DISPLAY

Displays information related to the current TV program.

### i+/? (Info/Text reveal)

Displays information such as current channel number and screen mode.

Reveals hidden information (e.g. answers to a quiz) while in the text mode.

## 8 Color buttons

Displays an operation guide on the TV screen when the color buttons are available. Follow the operation guide to perform a selected operation.

## 11 TOOLS/OPTIONS

Displays the TV function options.

continued

**12 MENU/HOME**

Displays the TV menus.

**14 TV CH +\*\*/- or PROG +\*\*/-**

Scans for the preset TV channels.



Selects the next or previous page while in the text mode.

**17 TV VOL +/- or  +/-**

Adjusts the TV volume.

**18 MUTING or **

Activates the TV's muting function.

**19 RETURN/EXIT **

Returns to the previous TV menu.

**20 GUIDE or **

Display the on-screen program guide.

**22 AUDIO\*\* or **



Changes the dual sound mode.



**26 INPUT or  (Input select)**

Selects the input signal (TV or video).



Holds the current page while in the text mode.

\* If you press AV  (**1**) and  (**2**) simultaneously, the receiver and connected equipment will turn off (SYSTEM STANDBY). The function of the AV  (**1**) changes automatically each time you press the input buttons (**3**).

\*\*The 5/TV, AUDIO/,  and TV CH +/ SOUND FIELD +/PROG +/ buttons have tactile dots. Use the tactile dots as references when operating the receiver.

## To control other Sony equipment

Be sure to hold down SHIFT (15) to activate the buttons printed in pink (page 12).

Name	Blu-ray Disc, DVD player	Satellite tuner, cable TV tuner	VCR	CD player
1 AV I/⏻*	Power	Power	Power	Power
3 <b>Numeric buttons**</b>	Track	Channel	Channel	Track
ENT/MEM	Enter	Enter	Enter	Enter
CLEAR	Clear	Clear	–	Track > 10
6 DISPLAY	Display	Display	Display	Display
7 POP UP/MENU	Menu	–	–	–
8 <b>Color buttons</b>	Menu, guide	Menu, guide	–	–
10 ⊕	Enter	Enter	Enter	–
↕/↔/↔/↔	Select	Select	Select	–
11 <b>TOOLS/OPTIONS</b>	Options menu	Options menu	–	–
12 <b>MENU/HOME</b>	Menu	Menu	Menu	–
13 ◀◀/▶▶	Search forward, backward	–	Fast forward, rewind	Fast forward, rewind
▶**	Play	–	Play	Play
◀◀/▶▶	Skip track	–	Search index	Skip track
⏸	Pause	–	Pause	Pause
■	Stop	–	Stop	Stop
19 <b>RETURN/EXIT</b> ⏪	Return	Return, exit	–	–
20 <b>GUIDE</b> or 📅	Program schedule	Guide menu	–	–
21 <b>TOP MENU</b>	On-screen guide	–	–	–
22 <b>AUDIO**</b> or 🎧**	Audio	–	–	–
26 <b>INPUT</b>	Select input	–	Select input	–

\* If you press AV I/⏻ (1) and I/⏻ (2) simultaneously, the receiver and connected equipment will turn off (SYSTEM STANDBY). The function of the AV I/⏻ (1) changes automatically each time you press the input buttons (3).

\*\*The 5/TV, AUDIO/🎧, ▶ and TV CH +/SOUND FIELD +/PROG +/⏪ buttons have tactile dots. Use the tactile dots as references when operating the receiver.

### Notes

- The above explanation is intended to serve as examples.
- Depending on the model of your connected equipment, some functions explained in this section may not work with the supplied remote control.

# Getting started

You can enjoy your audio/video equipment connected to the receiver by following the simple steps below.

## Installing and connecting the speakers (page 17, 19)



## Checking the connection appropriate for your equipment

### Connecting the TV and video equipment (page 21, 22)

The image quality depends on the connecting jack. See the illustration below. Select the connection according to the jacks on your equipment.

We recommend that you connect your video equipment via HDMI connection if they have HDMI jacks.

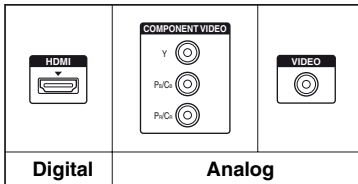

High quality image



## Connecting the audio equipment (page 28)



## Setting the audio output settings on the connected equipment

To output multi channel digital audio, check the digital audio output setting on the connected equipment.

For a Blu-ray Disc player, check that “Audio (HDMI)”, “Dolby Digital (Coaxial/Optical)”, and “DTS (Coaxial/Optical)” are set to “Auto”, “Dolby Digital” and “DTS” respectively (as of September 2010).

For a PlayStation 3, check that “BD/DVD Audio Output Format (HDMI)” is set to “Bitstream” (with system software version 3.5).

For details, refer to the operating instructions supplied with the connected equipment.



## Preparing the receiver

See “6: Connecting the AC power cord (mains lead)” (page 29) and “Initializing the receiver” (page 29).



## Setting the speakers

(USA and Canada models only)

Select the speaker pattern (page 30), then check the speaker connection using “T. TONE” in LEVEL menu (page 35). If the sound is not output correctly, check the speaker connection and make the settings explained above again.

(Other models)

Select the speaker pattern (page 30), then perform Auto Calibration (page 31).

You can check the speaker connection using “T. TONE” in LEVEL menu (page 35). If the sound is not output correctly, check the speaker connection and make the settings explained above again.

# 1: Installing the speakers

This receiver allows you to use a 7.1 channel system (7 speakers and one subwoofer).

## Example of speaker system configuration

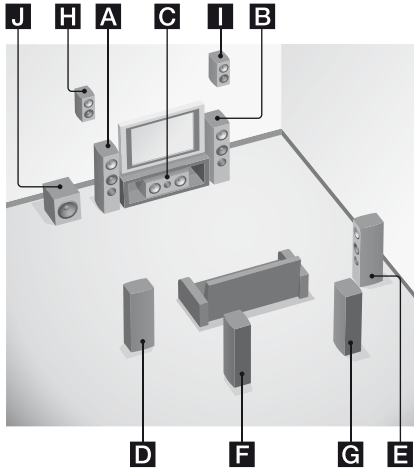

- A** Front speaker (Left)
- B** Front speaker (Right)
- C** Center speaker
- D** Surround speaker (Left)
- E** Surround speaker (Right)
- F** Surround back speaker (Left)\*
- G** Surround back speaker (Right)\*
- H** Front high speaker (Left)\*
- I** Front high speaker (Right)\*
- J** Subwoofer

\* You cannot use the surround back speakers and the front high speakers simultaneously.

## 5.1 channel speaker system

To fully enjoy theater-like multi channel surround sound requires five speakers (two front speakers, a center speaker, and two surround speakers) and a subwoofer.

## 7.1 channel speaker system using surround back speakers

You can enjoy high fidelity reproduction of DVD or Blu-ray Disc software recorded sound in 6.1 channel or 7.1 channel format by connecting additional one surround back speaker (6.1 channel) or two surround back speakers (7.1 channel).

## 7.1 channel speaker system using front high speakers

You can enjoy vertical sound effects by connecting additional two front high speakers in Dolby Pro Logic IIz mode (page 44).

## Tips

- When you connect a 7.1 channel speaker system with two surround back speakers, all the angles **A** should be the same.

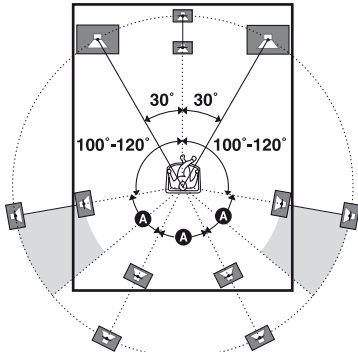

- When you connect a 7.1 channel speaker system with two front high speakers
  - at an angle between 22° to 45°.
  - at least 1 meter (3.3 feet) directly above the front speakers.

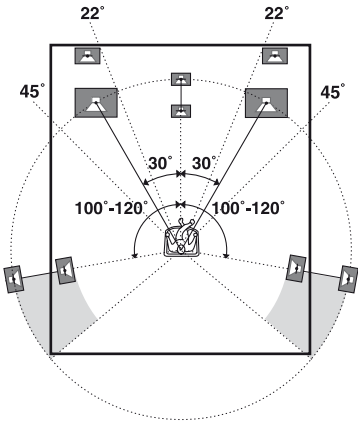

- When you connect a 6.1 channel speaker system, place the surround back speaker behind the seating position.

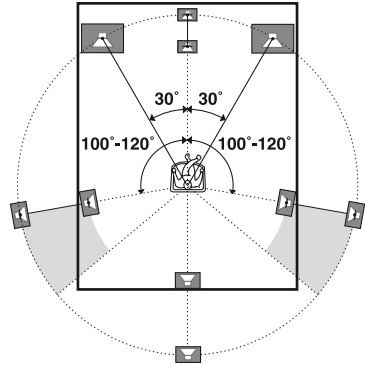

- Since the subwoofer does not emit highly directional signals, you can place it wherever you want.

## 2: Connecting the speakers

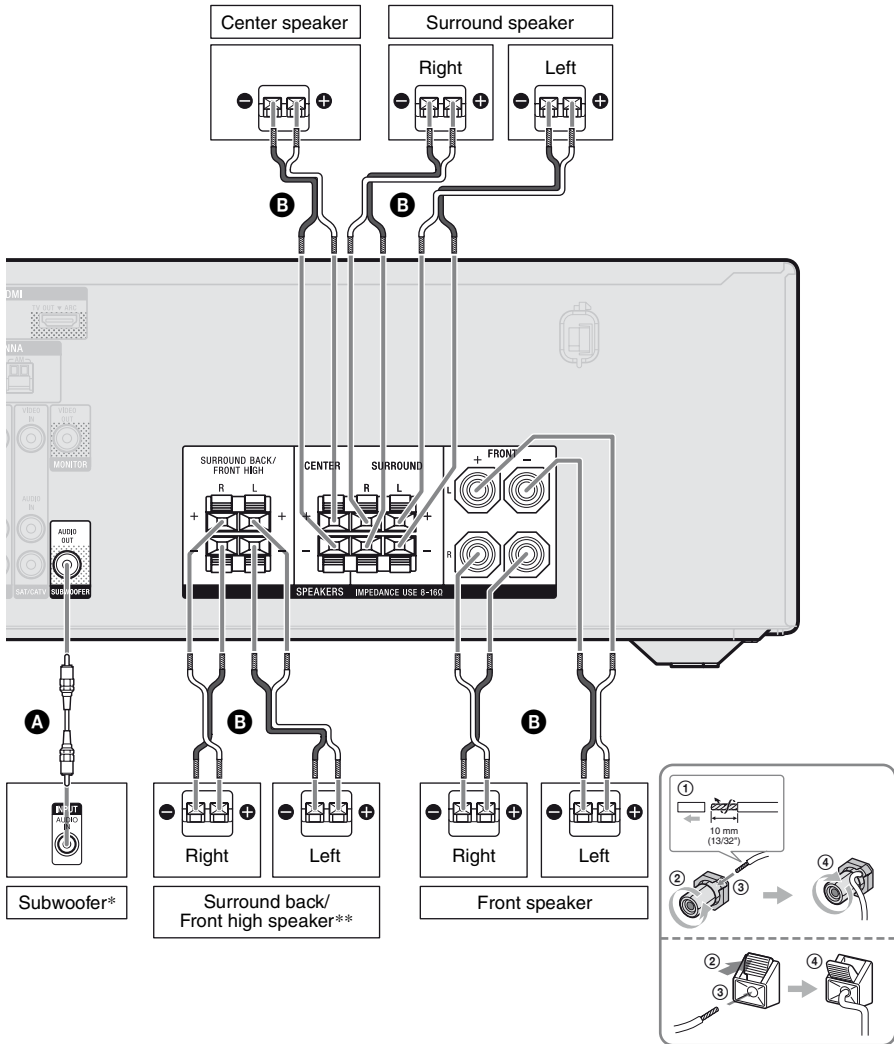

- A** Monaural audio cord (not supplied)
- B** Speaker cord (not supplied)

- \* When you connect a subwoofer with an auto standby function, turn off the function when watching movies. If the auto standby function is set to on, it turns to standby mode automatically based on the level of the input signal to the subwoofer, and the sound may not be output.
- \*\* If you connect only one surround back speaker, connect it to the SPEAKERS SURROUND BACK/FRONT HIGH L terminal.

## **Notes**

- Before connecting the cords, be sure to disconnect the AC power cord (mains lead).
- Before connecting the AC power cord (mains lead), make sure that metallic wires of the speaker cords are not touching each other within the SPEAKERS terminals.
- After you have install and connect your speaker, be sure to select the speaker pattern from SPEAKER menu (page 30).

# 3: Connecting the TV

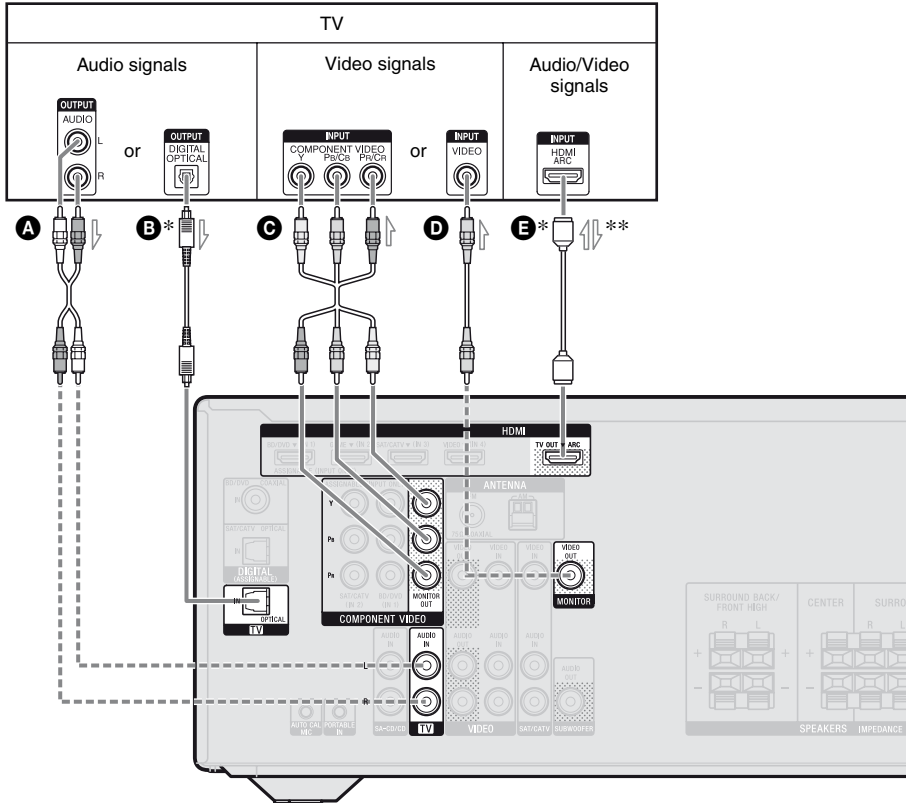

- A** Audio cord (not supplied)
- B** Optical digital cord (not supplied)
- C** Component video cord (not supplied)
- D** Video cord (not supplied)
- E** HDMI cable (not supplied)

Sony recommends that you use an HDMI-authorized cable or Sony HDMI cable.

— Recommended connection  
 - - - - Alternative connection

\* To enjoy the TV broadcast in multi channel surround sound from the speakers connected to the receiver, you can make either one of the following connections:

- connect **Ⓓ**.
- connect **Ⓔ** if your TV is compatible with the Audio Return Channel (ARC) function.

Be sure to turn off the TV's volume or activate the TV's muting function.

\*\* If you connect the receiver to the Audio Return Channel (ARC) compatible TV, the TV sound will output from the speakers connected to the receiver via the HDMI TV OUT jack. Be sure to set the "CTRL.HDMI" to "CTRL ON" in HDMI menu (page 56). If you want to select an audio signal using other than an HDMI cable (e.g., via an optical digital cord or an audio cord), switch the audio input mode using INPUT MODE (page 51).

## Notes

- Before connecting cords, be sure to disconnect the AC power cord (mains lead).
- Be sure to turn the receiver on when the video and audio signals of a playback equipment are being output to a TV via the receiver. Unless the power is turned on, neither video nor audio signals will be transmitted.
- Connect a TV monitor or a projector to the HDMI TV OUT or MONITOR OUT jack on the receiver. You may not be able to record even if you connect recording equipment.
- Depending on the status of the connection between the TV and the antenna (aerial), the image on the TV screen may be distorted. If this is the case, place the antenna (aerial) farther away from the receiver.
- When connecting optical digital cords, insert the plugs straight until they click into place.
- Do not bend or tie optical digital cords.

## Tips

- All the digital audio jacks are compatible with 32 kHz, 44.1 kHz, 48 kHz, and 96 kHz sampling frequencies.
- When you connect the audio output jack of the TV to the TV IN jacks of the receiver to output the TV sound from the speakers connected to the receiver, set the sound output jack of the TV to "Fixed" if it can be switched between either "Fixed" or "Variable".

# 4a: Connecting the video equipment

## Using HDMI connection

High-Definition Multimedia Interface (HDMI) is an interface which transmits video and audio signals in digital format.

By connecting Sony "BRAVIA" Sync-compatible equipment using HDMI cables, operations can be simplified. See "BRAVIA" Sync Features" (page 47).

## HDMI features

- A digital audio signals transmitted by HDMI can be output from the speakers connected to the receiver. This signal supports Dolby Digital, DTS, and Linear PCM. For details, see "Digital audio formats supported by the receiver" (page 46).
- The receiver can receive Multi Channel Linear PCM (up to 8 channels) with a sampling frequency of 192 kHz or less with an HDMI connection.
- This receiver supports High Bitrate Audio (DTS-HD Master Audio, Dolby TrueHD), Deep Color (Deep Colour), x.v.Color (x.v.Colour) and 3D transmission.

## Notes on HDMI connections

- An audio signal input to the HDMI IN jack is output through the SPEAKERS terminals, HDMI TV OUT jack and PHONES jack. It is not output through any other audio jacks.
- Video signals input to the HDMI IN jack can only be output through the HDMI TV OUT jack. The video input signals cannot be output through the VIDEO OUT jacks or MONITOR OUT jacks.
- When you want to listen to the sound from the TV speaker, set the "AUDIO.OUT" to "TV+AMP" in the HDMI menu (page 60). If you cannot play back multi channel audio source, set to "AMP". However, the sound will not output through the TV speaker.

- DSD signals of Super Audio CD are not input and output.
- Be sure to turn the receiver on when the video and audio signals of a playback equipment are being output to a TV via the receiver. If you set the “PASS.THROUGH” to “OFF”, video and audio signals will not be transmitted when the power is turned off.
- Audio signals (format, sampling frequency, bit length, etc.) transmitted from an HDMI jack may be suppressed by the connected equipment. Check the setup of the connected equipment if the image is poor or the sound does not come out of a equipment connected via the HDMI cable.
- Sound may be interrupted when the sampling frequency, the number of channels or audio format of audio output signals from the playback equipment is switched.
- When the connected equipment is not compatible with copyright protection technology (HDCP), the image and/or the sound from the HDMI TV OUT jack may be distorted or may be lost.  
If this is the case, check the specification of the connected equipment.
- You can enjoy High Bitrate Audio (DTS-HD Master Audio, Dolby TrueHD), Multi Channel Linear PCM only with an HDMI connection.
- Set the image resolution of the playback equipment to more than 720p/1080i to enjoy High Bitrate Audio (DTS-HD Master Audio, Dolby TrueHD).
- The image resolution of the playback equipment may need to be at certain settings before you can enjoy Multi Channel Linear PCM. Refer to the operating instructions of the playback equipment.
- To enjoy 3D images, connect 3D-compatible TV and video equipment (Blu-ray Disc player, Blu-ray Disc recorder, PlayStation 3, etc.) to the receiver using High Speed HDMI cables, put on 3D glasses, and then play back a 3D-compatible content.
- Depending on the TV or the video equipment, 3D images may not be displayed.
- Not every HDMI equipment supports all functions that are defined by the specific HDMI version. For example, equipment that support HDMI, version 1.4, may not support Audio Return Channel (ARC).
- Refer to the operating instructions of each connected equipment for details.

## When connecting cords

- Before connecting cords, be sure to disconnect the AC power cord (mains lead).
- It is not necessary to connect all the cords. Connect according to the availability of jacks on the connected equipment.
- Use a High Speed HDMI cable. If you use a Standard HDMI cable, 1080p, Deep Color (Deep Colour) or 3D images may not be displayed properly.
- We do not recommend using an HDMI-DVI conversion cable. When you connect an HDMI-DVI conversion cable to a DVI-D equipment, the sound and/or the image may be lost. Connect a separate audio cords or digital connecting cords, then set the “A. ASSIGN” in AUDIO menu (page 51) when the sound is not output correctly.
- When connecting optical digital cords, insert the plugs straight until they click into place.
- Do not bend or tie optical digital cords.

### Tip

All the digital audio jacks are compatible with 32 kHz, 44.1 kHz, 48 kHz, and 96 kHz sampling frequencies.

### If you want to connect several digital equipment, but cannot find an unused input

See “Using the sound/images from other inputs” (page 51).

# Connecting a Blu-ray Disc player, DVD player

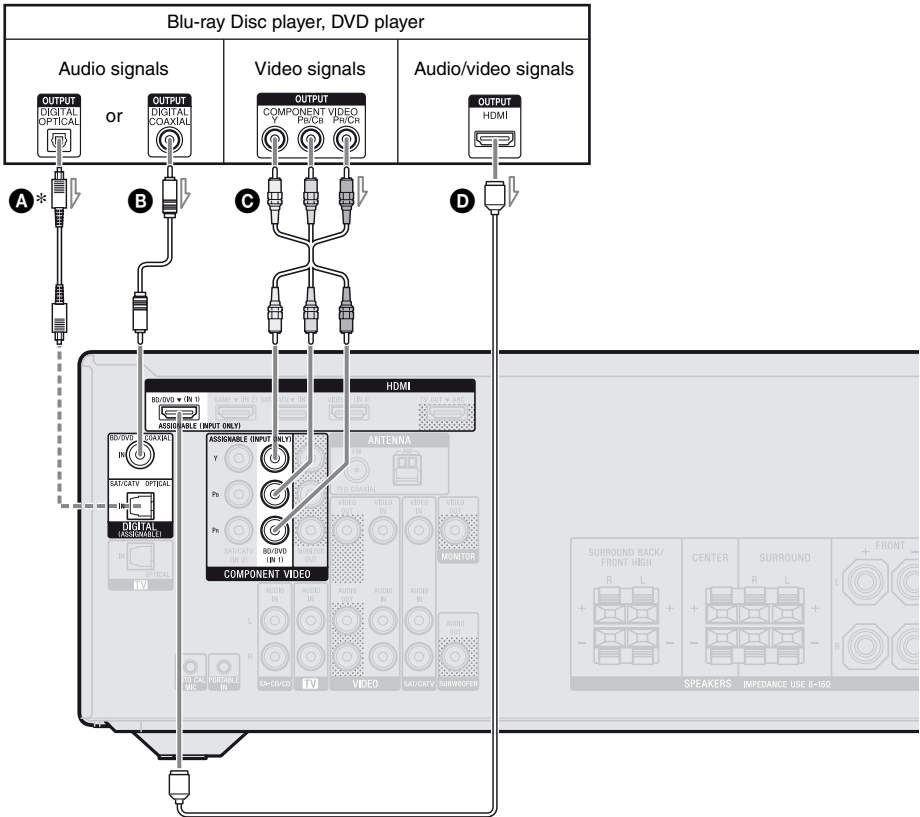

- A** Optical digital cord (not supplied)
- B** Coaxial digital cord (not supplied)
- C** Component video cord (not supplied)
- D** HDMI cable (not supplied)

**Sony recommends that you use an HDMI-authorized cable or Sony HDMI cable.**

— Recommended connection  
 - - - - Alternative connection

\* When you connect equipment equipped with a OPTICAL jack, set the “A. ASSIGN” in the AUDIO menu (page 51).

## Notes

- Be sure to change the default setting of the BD/DVD input button on the remote control so that you can use the button to control your DVD player. For details, see “Reassigning the input button” (page 61).
- You can also rename the BD/DVD input so that it can be displayed on the receiver’s display panel. For details, see “Naming inputs” (page 37).

# Connecting a PlayStation 3

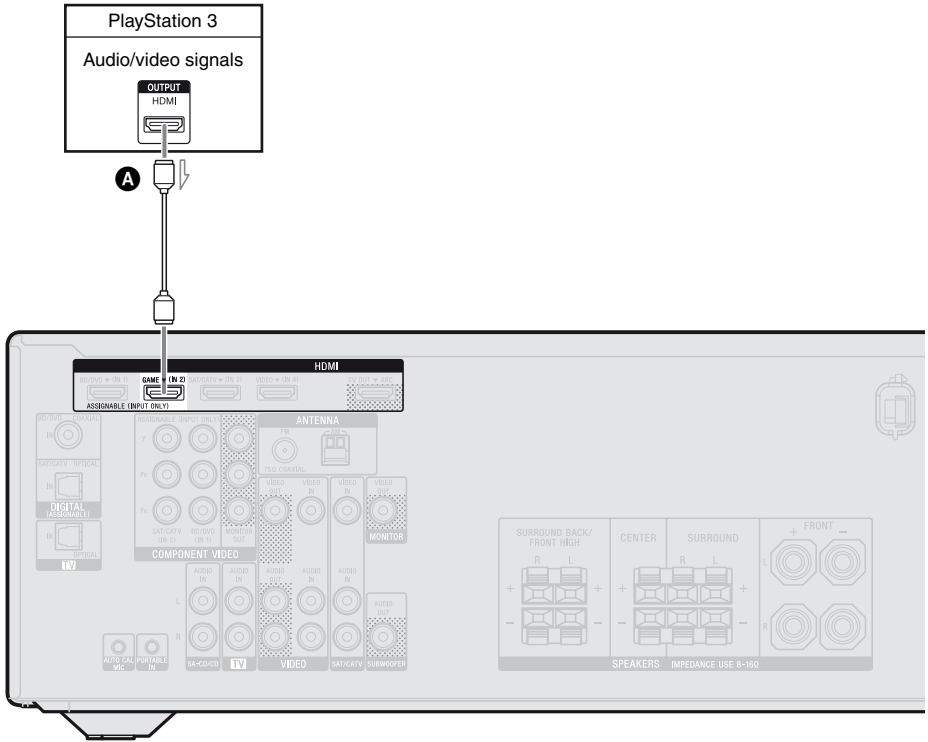

- A** HDMI cable (not supplied)  
Sony recommends that you use an HDMI-authorized cable or Sony HDMI cable.

# Connecting a satellite tuner, cable TV tuner

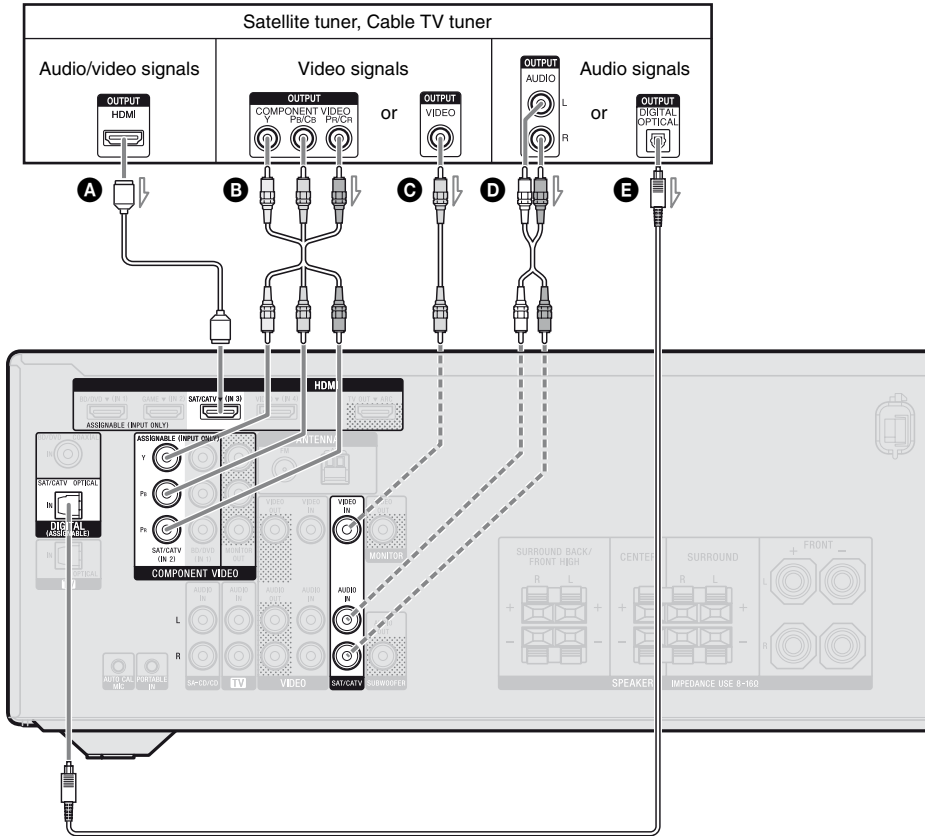

- A** HDMI cable (not supplied)  
Sony recommends that you use an HDMI-authorized cable or Sony HDMI cable.
- B** Component video cord (not supplied)
- C** Video cord (not supplied)
- D** Audio cord (not supplied)
- E** Optical digital cord (not supplied)

— Recommended connection  
 - - - Alternative connection

# Connecting a VCR, DVD recorder

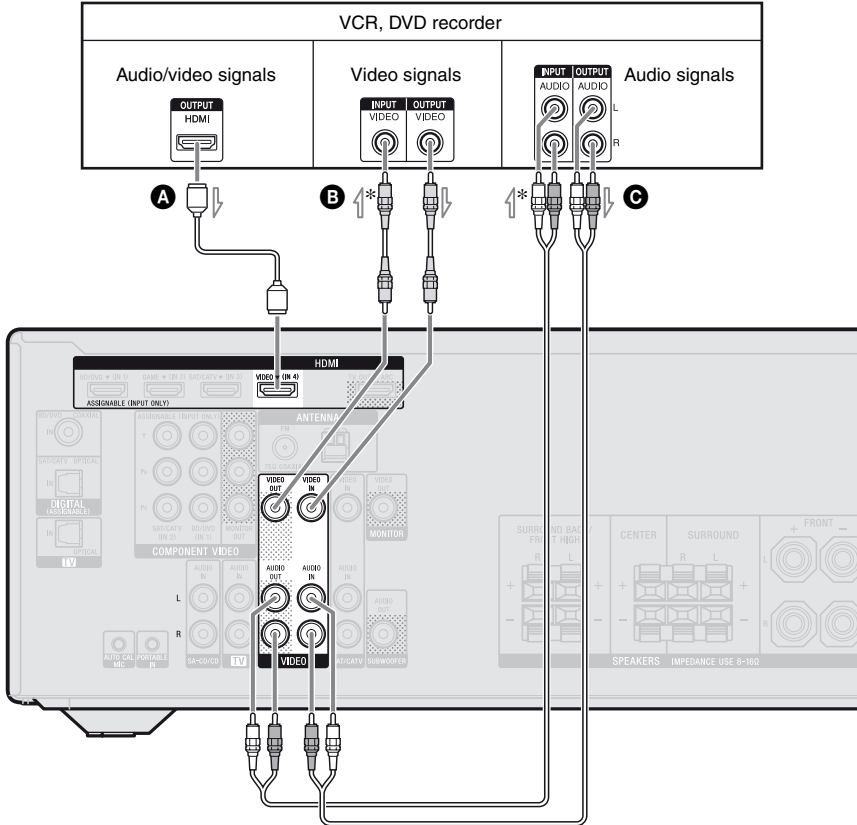

- A** HDMI cable (not supplied)  
Sony recommends that you use an HDMI-authorized cable or Sony HDMI cable.
- B** Video cord (not supplied)
- C** Audio cord (not supplied)

\* If you want to record, you must make this connection (page 38).

## Note

Be sure to change the default setting of the VIDEO input button on the remote control so that you can use the button to control your DVD recorder. For details, see “Reassigning the input button” (page 61).

## 4b: Connecting the audio equipment

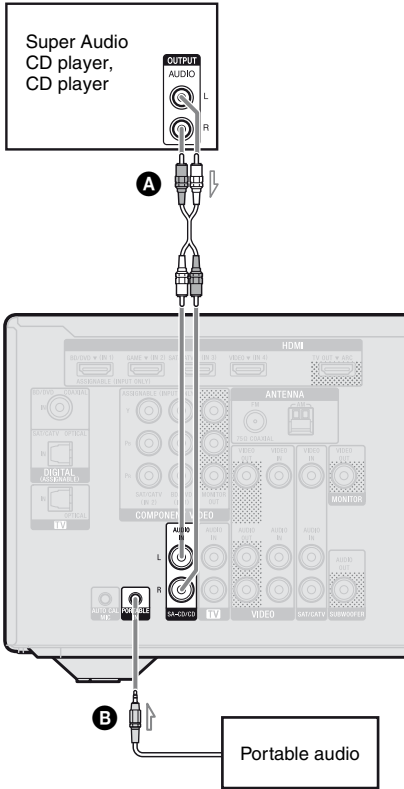

- A** Audio cord (not supplied)
- B** Phono cord with stereo headphone jack (not supplied)

### Notes

- Before connecting cords, be sure to disconnect the AC power cord (mains lead).
- When listening to a equipment connected to the PORTABLE IN jack, sound may be distorted or interrupted. This is not a malfunction and will depend on the connected equipment.
- If the sound from the equipment connected to the PORTABLE IN jack is very soft, you may increase the volume level. However, before you switch to other input, be sure to reduce the volume level to avoid damaging your speaker.

### Tip

We recommend you to use “P. AUDIO” sound field if the source is MP3 or other compressed source.

## 5: Connecting the antennas (aerials)

Before connecting antennas (aerials), be sure to disconnect the AC power cord (mains lead).

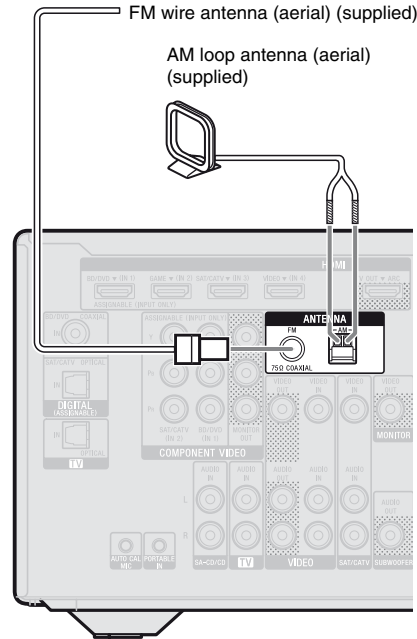

### Notes

- To prevent noise pickup, keep the AM loop antenna (aerial) away from the receiver and other equipment.
- Be sure to fully extend the FM wire antenna (aerial).
- After connecting the FM wire antenna (aerial), keep it as horizontal as possible.

## 6: Connecting the AC power cord (mains lead)

Connect the AC power cord (mains lead) to a wall outlet.

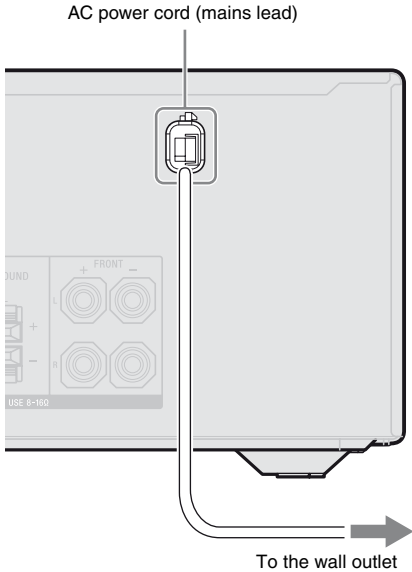

### Note

Be sure to turn the receiver on when the video and audio signals of a playback equipment are being output to a TV via the receiver. Unless the power is turned on, neither video nor audio signals will be transmitted.

## Preparing the Receiver

### Initializing the receiver

Before using the receiver for the first time, initialize the receiver by performing the following procedure. This procedure can also be used to revert back to the factory default settings.

Be sure to use the buttons on the receiver to perform this operation.

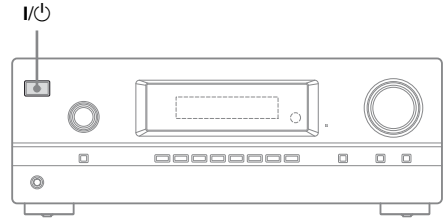

- 1 Press I/Power to turn off the receiver.**
- 2 Hold down I/Power for 5 seconds.**

The “CLEARING” appears on the display panel for a while, then changes to “CLEARED”.

Changes or adjustments made to the settings are now reset to the defaults.

# Selecting the speaker pattern

Select the speaker pattern according to the speaker system which you are using.

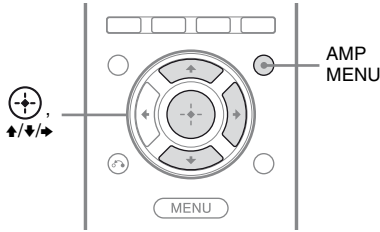

- 1** Press AMP MENU.
- 2** Press  $\uparrow/\downarrow$  repeatedly to select “SPKR”, then press  $\oplus$  or  $\rightarrow$ .
- 3** Press  $\uparrow/\downarrow$  repeatedly to select “PATTERN”, then press  $\oplus$  or  $\rightarrow$ .
- 4** Press  $\uparrow/\downarrow$  repeatedly to select the speaker pattern you want, then press  $\oplus$ .

## Speaker pattern settings

For example:

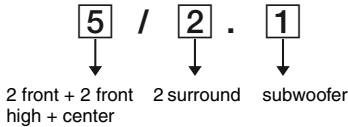

Speaker pattern	Front left/right	Front left/right high	Center	Surround left/right	Surround back left	Surround back right	Subwoofer
5/2.1	○	○	○	○	–	–	○
5/2	○	○	○	○	–	–	–
4/2.1	○	○	–	○	–	–	○
4/2	○	○	–	○	–	–	–
3/4.1	○	–	○	○	○	○	○
3/4	○	–	○	○	○	○	–
2/4.1	○	–	–	○	○	○	○
2/4	○	–	–	○	○	○	–
3/3.1	○	–	○	○	○	–	○
3/3	○	–	○	○	○	–	–
2/3.1	○	–	–	○	○	–	○
2/3	○	–	–	○	○	–	–
3/2.1	○	–	○	○	–	–	○
3/2	○	–	○	○	–	–	–
2/2.1	○	–	–	○	–	–	○
2/2	○	–	–	○	–	–	–
3/0.1	○	–	○	–	–	–	○
3/0	○	–	○	–	–	–	–
2/0.1	○	–	–	–	–	–	○
2/0	○	–	–	–	–	–	–

# Using AUTO CALIBRATION

## (Europe, Australia and Taiwan models only)

This receiver is equipped with DCAC (Digital Cinema Auto Calibration) Technology which allows you to perform automatic calibration as follows:

- Check the connection between each speaker and the receiver.\*
- Adjust the speaker level.
- Measure the distance of each speaker from your seating position.\*
- Measure the speaker size.\*
- Measure the frequency characteristics.\*

\* The measurement result is not utilized when "A. DIRECT" is selected.

The DCAC is designed to achieve proper sound balance for your room. However, you can adjust the speaker levels manually according to your preference. For details, see "Adjusting the speaker levels (TEST TONE)" (page 35).

## Before you perform Auto Calibration

Before you perform Auto Calibration, check the following items:

- Set up and connect the speakers (page 17, 19).
- Connect only the supplied optimizer microphone to the AUTO CAL MIC jack. Do not connect any other microphones to this jack.
- Disconnect the headphones.
- Remove any obstacles in the path between the optimizer microphone and the speakers to avoid measurement error.
- Get accurate measurement by making sure the environment is free from noise and quiet.

## Notes

- The speakers emit very loud sound during the calibration and the volume cannot be adjusted. Provide consideration to your neighborhood and to the children in presence.
- If the muting function has been activated before you perform Auto Calibration, the muting function will shut off automatically.
- The correct measurements may not be able to take or Auto Calibration cannot be performed when special speakers, such as dipole speakers are used.

## 1: Setting up the Auto Calibration

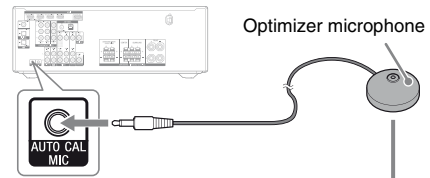

### Example of using surround back speakers

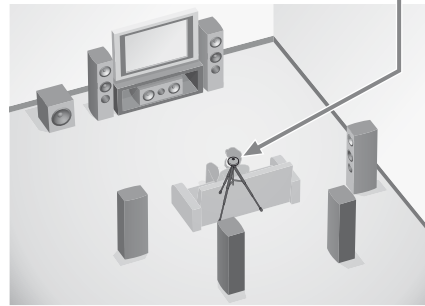

## 1 Select the speaker pattern (page 30).

If you connect front high speakers, select the speaker pattern that has front high speakers (5/■.■ or 4/■.■) each time you perform Auto Calibration. Otherwise, the characteristics of the front high speakers cannot be measured.

## 2 Connect the supplied optimizer microphone to the AUTO CAL MIC jack.

*continued*

### 3 Set up the optimizer microphone.

Place the optimizer microphone at your seating position. Use a stool or tripod so that the optimizer microphone remains at the same height as your ears.

### Confirm active subwoofer setup

- When a subwoofer is connected, turn on the subwoofer and turn up the volume prior to activating the subwoofer. Turn the LEVEL knob to just before the mid-point.
- If you connect a subwoofer with a crossover frequency function, set the value to the maximum.
- If you connect a subwoofer with an auto standby function, set it to off (deactivated).

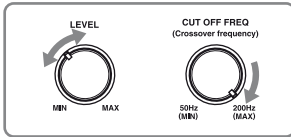

### Note

Depending on the characteristics of the subwoofer you are using, the setup distance value may be different from the actual position.

## 2: Performing Auto Calibration

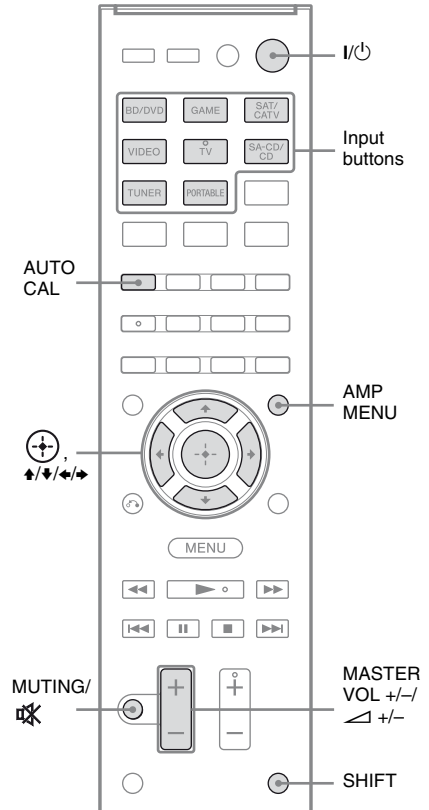

### Hold down SHIFT, then press AUTO CAL.

“STANDARD” Auto Calibration is automatically selected and the default calibration type is “ENGINEER”. Measurement starts in 5 seconds. The measurement process will take approximately 30 seconds to complete.

The table below provides measurement status shown on the display panel.

Measurement for	Display
Speaker existence	TONE
Speaker gain, distance, frequency response	T. S. P.*
Subwoofer gain and distance	WOOFER*

\* The corresponding speaker indicator lights up in the display panel during measurement.

### Tips

- You can also select the calibration type you want and perform the Auto Calibration by using the “CUSTOM” in AUTO CAL menu (page 35).
- You can change the unit of distance in “DIST.UNIT” in SPEAKER menu (page 58).

## To cancel Auto Calibration

The Auto Calibration function will be canceled when you perform the following during the measurement process:

- Press I/⏻.
- Press the input buttons or turn the INPUT SELECTOR on the receiver.
- Change the volume level.
- Press MUTING or 🚫.
- Connect headphones.
- Press AUTO CAL again.

## 3: Confirming/saving the measurement results

### 1 Confirm the measurement result.

When the measurement process is completed, the result appears on the display panel with a beep sound.

Measurement process [Display]	Do this
Completes properly [SAVE.EXIT]	Proceed to step 2.
Fails [E - ■■■■ ■■■]	See “When error codes appear” (page 34).

### 2 View the measurement result.

Press ▲/▼ repeatedly to select the item. Then, press ⊕.

- EXIT  
Exits the setting process without saving the measurement results.
- WARN CHK  
Displays warning related to the measurement results. See “Checking the warning message” (page 34).
- SAVE.EXIT  
Saves the measurement results and exits the setting process.
- RETRY  
Performs the Auto Calibration again.

### 3 Save the measurement result.

Select “SAVE.EXIT” in step 2. “COMPLETE” appears on the display panel and the settings are saved.

### 4 Disconnect the optimizer microphone from the receiver.

#### Note

If you reposition your speaker, we recommend that you perform Auto Calibration again to enjoy the surround sound.

#### Tip

The size of a speaker (LARGE/SMALL) is determined by the low frequency characteristics. The measurement results may vary, depending on the position of the optimizer microphone and speakers, and the shape of the room. It is recommended that you apply the measurement results. However, you can change those settings in the SPEAKER menu (page 54). Save the measurement results first, then try to change the settings.

## When error codes appear

### 1 Check the problem of the error.

---

#### Display and explanation

---

##### E - ■■■■\* 32

None of the speakers were detected. Make sure that the optimizer microphone is connected properly and perform the Auto Calibration again. If the optimizer microphone is connected properly but the error code still appears, the optimizer microphone cable may be damaged.

##### E - ■■■■\* 33

- None of the front speakers are connected or only one front speaker is connected.
- The optimizer microphone is not connected.
- Either the left or right surround speakers is not connected.
- Surround back speakers or front high speakers are connected even though surround speakers are not meant to be connected. Connect the surround speaker(s) to the SPEAKERS SURROUND terminals.  
The surround back speaker is connected only to the SPEAKERS SURROUND BACK/FRONT HIGH R terminals. When you connect only one surround back speaker, connect it to the SPEAKERS SURROUND BACK/FRONT HIGH L terminals.
- Either the front left high or front right high speaker is not connected.

---

\* ■■■■ represent a speaker channel

F	Front
S	Surround
SB	Surround back
FH	Front high

Depending on the error code, the speaker channel may not appear.

### 2 Perform Auto Calibration again.

Press ⊕. “RETRY Y” will appear on the display panel, then press ⊕.

### 3 Repeat steps in “3: Confirming/saving the measurement results” (page 33).

## Checking the warning message

If a warning on the measurement result is present, detailed information is displayed.

---

#### Display and explanation

---

##### W - ■■■■\* 40

The measurement process has completed with high noise level detection. You may be able to achieve better results if you try in a quiet environment again.

##### W - ■■■■\* 41

##### W - ■■■■\* 42

The input from the microphone is too big. The distance between the speaker and the microphone may be too close. Set them apart and perform the measurement again.

##### W - ■■■■\* 43

The distance and position of a subwoofer cannot be detected. This may be caused by noise. Try to perform the measurement in a quiet environment.

---

#### NO WARN

There is no warning information.

---

\* ■■■■ represent a speaker channel

FL	Front left
FR	Front right
CNT	Center
SL	Surround left
SR	Surround right
SBL	Surround back left
SBR	Surround back right
LH	Front left high
RH	Front right high
SW	Subwoofer

Depending on the measurement result, the speaker channel may not appear.

## To return to step 2 of “3: Confirming/saving the measurement results”

Press ⊕.

### Tip

Depending on the position of the subwoofer, the measurement results may vary. However, there will be no problems even if you continue to use the receiver with that value.

## Selecting the calibration type

You can select the calibration type you want and then perform the Auto Calibration.

- 1** Press **AMP MENU**.
- 2** Press **↑/↓** repeatedly to select **“A. CAL”**, then press **⊕** or **➡**.
- 3** Press **↑/↓** repeatedly to select **“CUSTOM”**, then press **⊕** or **➡**.
- 4** Press **↑/↓** repeatedly to select the calibration type you want, then press **⊕**.

- **FULL.FLAT**  
Makes the measurement of frequency from each speaker flat.
- **ENGINEER**  
Sets to “the Sony listening room standard” frequency characteristics.
- **FRONT.REF**  
Adjusts the characteristics of all the speakers to match the characteristics of the front speaker.
- **OFF**  
Sets the Auto Calibration equalizer level to off.

The Auto Calibration starts automatically.

- 5** Save the measurement result (page 33).

## Adjusting the speaker levels (TEST TONE)

You can adjust the speaker levels while listening to the test tone from your seating position.

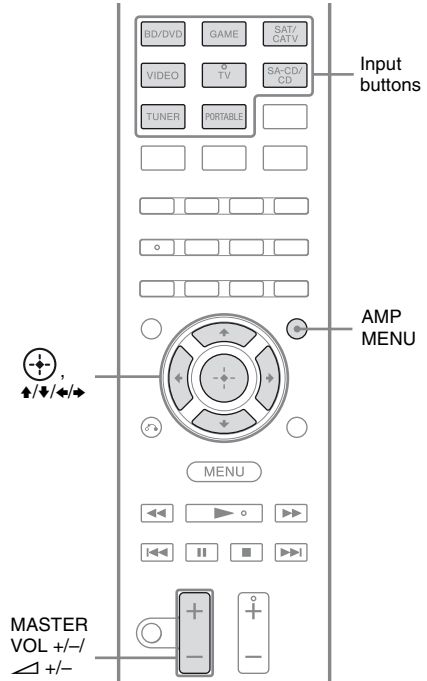

- 1** Press **AMP MENU**.
- 2** Press **↑/↓** repeatedly to select **“LEVEL”**, then press **⊕** or **➡**.
- 3** Press **↑/↓** repeatedly to select **“T. TONE”**, then press **⊕**.

## Playback

### 4 Press $\uparrow/\downarrow$ repeatedly to select “AUTO ■■■\*”.

The test tone is output from each speaker in sequence.

\* ■■■ represent a speaker channel.

#### Note

Depending on the speaker pattern settings, test tone may not be output from all speakers even though you selected “AUTO ■■■”.

### 5 Adjust the speaker levels.

Use the LEVEL menu (page 54) to adjust the speakers to have the same sounding test tone level for each speaker.

#### Tips

- To adjust the level of all speakers at the same time, press MASTER VOL +/- or  $\triangle$  +/- . You can also use MASTER VOLUME on the receiver.
- The adjusted value are shown on the display panel during adjustment.

### 6 Exit test tone.

Press any input buttons or select “OFF” under step 4.

### When a test tone is not output from the speakers

- The speaker cords may not be connected securely.
- The speaker cords may have the short-circuit problem.

### When a test tone is output from a different speaker than the speaker indicator showed in the display panel

The speaker pattern set up is incorrect. Make sure that the speaker connections and the pattern match correctly.

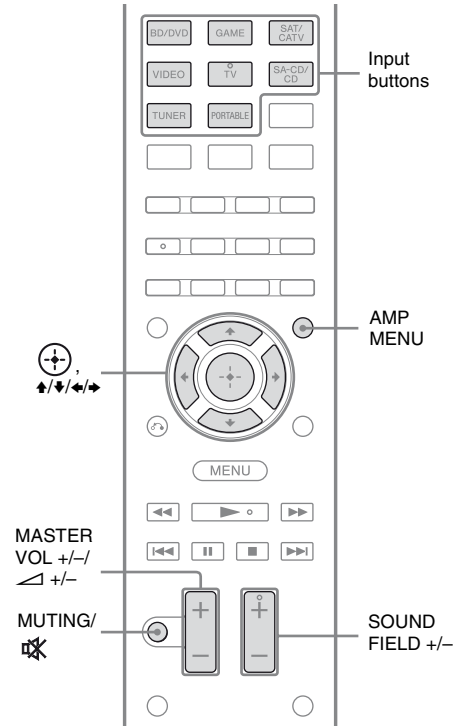

### 1 Turn on the connected equipment.

### 2 Turn on the receiver.

### 3 Press the input button which corresponds to the equipment you want.

You can also use INPUT SELECTOR on the receiver.

The selected input appears on the display panel.

#### Note

When you press TUNER, “FM TUNER” or “AM TUNER” appears for a while, and then frequency appears on the display panel.

- 4 **Play back the source.**
- 5 **Press MASTER VOL +/- or  $\triangle$  +/- to adjust the volume.**  
You can also use MASTER VOLUME on the receiver.
- 6 **Press SOUND FIELD +/- to enjoy the surround sound.**  
You can also use 2CH/A.DIRECT, A.F.D., MOVIE/HD-D.C.S. or MUSIC on the receiver.  
For details, see page 43.

### To activate the muting function

Press MUTING or  $\times$  on the remote control. The muting function will be canceled when you do the following.

- Press the button again.
- Increase the volume.
- Turn off the receiver.
- Perform Auto Calibration.

### To avoid damaging your speakers

Before you turn off the receiver, be sure to turn down the volume level.

### Naming inputs

You can enter a name of up to 8 characters for inputs (except TUNER) to appear on the display panel.

It is more recognizable having the equipment named on the display than the jacks.

- 1 **Press the corresponding input button which you want to create an index name.**  
You can also use INPUT SELECTOR on the receiver.
- 2 **Press AMP MENU.**
- 3 **Press  $\uparrow/\downarrow$  repeatedly to select “SYSTEM”, then press  $\odot$  or  $\rightarrow$ .**

- 4 **Press  $\uparrow/\downarrow$  repeatedly to select “NAME IN”, then press  $\odot$  or  $\rightarrow$ .**  
The cursor flashes and you can enter a character.
- 5 **Press  $\uparrow/\downarrow$  to select a character, then press  $\leftarrow/\rightarrow$  to move the input position backward and forward.**

#### Tips

- You can select the character type as follows by pressing  $\uparrow/\downarrow$ .  
Alphabet (upper case)  $\rightarrow$  Numbers  $\rightarrow$  Symbols
- To enter a blank space, press  $\rightarrow$  without selecting a character.

#### If you made a mistake

Press  $\leftarrow/\rightarrow$  until the character you want to change flashes, then press  $\uparrow/\downarrow$  to select the correct character.

- 6 **Press  $\odot$ .**

The name you entered is registered.

## Viewing information on the display panel

The display panel provides various information of the receiver status such as sound field.

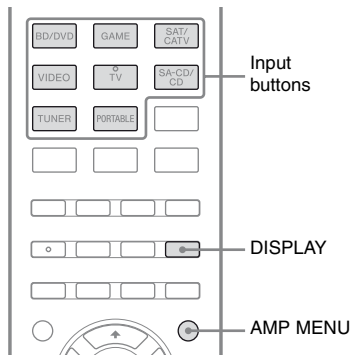

continued

**1 Press the corresponding input button which you want to check the information.**

**2 Press AMP MENU, then press DISPLAY repeatedly.**

Each time you press the button, the display changes cyclically as follows:

Index name of the input\* → Selected input → Sound field currently applied → Volume level → Stream info\*\*

**When listening to FM and AM radio**

Preset station name\* → Frequency → Sound field currently applied → Volume level

**When receiving RDS broadcasts (Europe, Australia and Taiwan models only)**

Program Service name or preset station name\* → Frequency, band and preset number → Sound field currently applied → Volume level

\* Index name appears only when you have assigned one to the input or preset station (page 37, 42). Index name does not appear when only blank spaces have been entered, or it is the same as the input name.

\*\*Stream information may not be displayed.

### Note

Character or marks may not be displayed for some languages.

## Recording using the receiver

You can record from an audio/video equipment using the receiver. Refer to the operating instructions supplied with your recording equipment.

**1 Press the input button which corresponds to the playback equipment.**

You can also use INPUT SELECTOR on the receiver.

**2 Prepare the playback equipment for playing.**

For example, insert the video tape you want to copy into the VCR.

**3 Prepare the recording equipment.**

Insert a blank video tape, etc. into the recording equipment (VIDEO) for recording.

**4 Start recording on the recording equipment, then start the playback equipment.**

### Notes

- Some sources contain copyright protection to prevent recording. In this case, you may not be able to record from the source.
- Only analog signals are output from the analog output jack (for recording).
- HDMI sound cannot be recorded.
- While only composite video signals are being recorded, the auto standby function of the receiver may start up and interrupt the recording. In this case, set the "AUTO.STBY" to "STBY OFF" (page 60).

## Tuner Operations

# Listening to FM/AM radio

You can listen to FM and AM broadcasts through the built-in tuner. Before operation, make sure you have connected the FM and AM antennas (aerials) to the receiver (page 28).

### Tip

The tuning scale for direct tuning is shown below.

Area	FM	AM
USA, Canada	100 kHz	10 kHz*
Europe, Australia, Taiwan	50 kHz	9 kHz

\* The AM tuning scale can be changed (page 40).

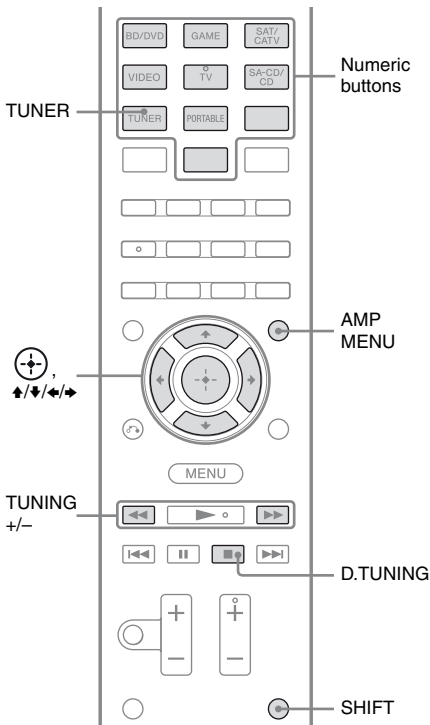

## Tuning to a station automatically (Automatic Tuning)

- 1 Press TUNER repeatedly to select the FM or AM band.**
- 2 Press TUNING + or TUNING -.**  
TUNING + scans from lower to higher frequency stations and TUNING - for scanning higher to lower.  
The receiver stops scanning whenever a frequency is received.

## Using the control buttons on the receiver

- 1 Turn INPUT SELECTOR to select the FM or AM band.**
- 2 Press TUNING MODE repeatedly to select "AUTO".**
- 3 Press TUNING + or TUNING -.**

## In case of poor FM stereo reception

If the FM stereo reception is poor and "ST" flashes on the display panel, select monaural audio to lessen the sound distortion.

- 1 Press AMP MENU.**
- 2 Press  $\uparrow/\downarrow$  repeatedly to select "TUNER", then press  $\odot$  or  $\rightarrow$ .**
- 3 Press  $\uparrow/\downarrow$  repeatedly to select "FM MODE", then press  $\odot$  or  $\rightarrow$ .**
- 4 Press  $\uparrow/\downarrow$  repeatedly to select "MONO", then press  $\odot$ .**

To return to stereo mode, repeat steps 1 to 4 and select "STEREO" in step 4.

## Tuning to a station directly (Direct Tuning)

You can enter the frequency of a station directly by using the numeric buttons.

### 1 Press TUNER repeatedly to select the FM or AM band.

You can also use INPUT SELECTOR on the receiver.

### 2 Press D.TUNING.

### 3 Hold down SHIFT, then press the numeric buttons to enter the frequency.

Example 1: FM 102.50 MHz

• USA and Canada models only:

Select 1 → 0 → 2 → 5

• Other models:

Select 1 → 0 → 2 → 5 → 0

Example 2: AM 1,350 kHz

Select 1 → 3 → 5 → 0

#### Tip

Adjust the direction of the AM loop antenna (aerial) for optimum reception upon tuning to an AM station.

### 4 Press $\oplus$ .

## If you cannot tune to a station

Make sure you have entered the right frequency. Try repeating steps 2 to 4. If you still cannot tune to a station, the frequency may not be in use in your area.

## Changing the AM tuning scale

### (USA and Canada models only)

You can change the AM tuning scale to either 9 kHz or 10 kHz using the buttons on the receiver.

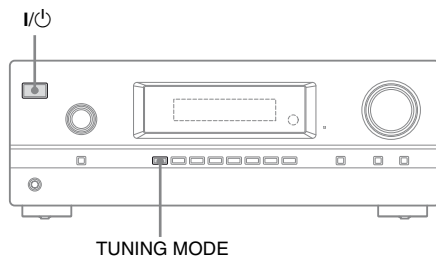

### 1 Press I/Power to turn off the receiver.

### 2 While holding down TUNING MODE, press I/Power.

### 3 Change the current AM tuning scale to 9 kHz (or 10 kHz).

To reset the scale to 10 kHz (or 9 kHz), repeat the procedure above.

#### Note

All preset stations will be erased when you change the tuning scale.

## Presetting FM/AM radio stations

You can store up to 30 FM and 30 AM stations as your favorite stations as preset stations.

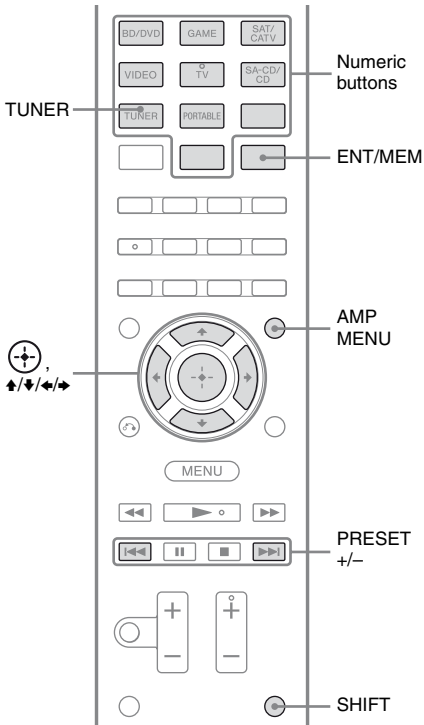

- 1 Press TUNER repeatedly to select the FM or AM band.**  
You can also use INPUT SELECTOR on the receiver.
- 2 Tune to the station that you want to preset using Automatic Tuning (page 39) or Direct Tuning (page 40).**
- 3 Hold down SHIFT, then press ENT/MEM.**  
You can also use MEMORY/ENTER on the receiver.

- 4 Hold down SHIFT, then press the numeric buttons to select a preset number.**

You can also press PRESET + or PRESET – to select a preset number.

- 5 Press  $\oplus$ .**

The station is stored as the selected preset number.

- 6 Repeat steps 1 to 5 to store another station.**

### Tuning to preset stations

- 1 Press TUNER repeatedly to select the FM or AM band.**
- 2 Press PRESET + or PRESET – repeatedly to select the station.**

Each time you press the button, you can select a preset station as follows:

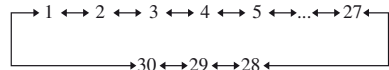

You can also hold down SHIFT and then press the numeric buttons to enter the preset station. To tune to the selection, press  $\oplus$ .

### Using the control buttons on the receiver

- 1 Turn INPUT SELECTOR to select the FM or AM band.**
- 2 Press TUNING MODE repeatedly to select “PRESET”.**
- 3 Press TUNING + or TUNING – to select the preset station you want.**

## Naming preset stations

- 1 Press **TUNER** repeatedly to select the **FM** or **AM** band.

You can also use **INPUT SELECTOR** on the receiver.

- 2 Tune to the preset station you want to create an index name for (page 41).

- 3 Press **AMP MENU**.

- 4 Press **▲/▼** repeatedly to select “**TUNER**”, then press **⊕** or **➔**.

- 5 Press **▲/▼** repeatedly to select “**NAME IN**”, then press **⊕** or **➔**.

The cursor flashes and you can enter a character.

- 6 Press **▲/▼** to select a character, then press **◀/▶** to move the input position backward and forward.

You can enter up to 8 characters to name the station.

### Tips

- You can select the character type as follows by pressing **▲/▼**.  
Alphabet (upper case) → Numbers → Symbols
- To enter a blank space, press **➔** without selecting a character.

### If you made a mistake

Press **◀/▶** until the character you want to change flashes, then press **▲/▼** to select the correct character.

- 7 Press **⊕**.

The name you entered is registered.

### Note (Europe, Australia and Taiwan models only)

When you name an RDS (Radio Data System) station and tune to that station, the Program Service name appears instead of the name you entered.

## Receiving RDS broadcasts

### (Europe, Australia and Taiwan models only)

This receiver allows you to use Radio Data System (RDS), which enables radio stations to send additional information along with the regular programming signal. This receiver offers convenient RDS features, such as Program Service name display. RDS is available only for FM stations.\*

\* Not all FM stations provide RDS service, nor do they provide the same type of services. If you are not familiar with the RDS services in your area, check with your local radio stations for details.

### Simply select a station on the FM band using Direct Tuning (page 40), Automatic Tuning (page 39), or Tuning with Preset Station (page 41).

When you tune to a station that provides RDS services, “RDS” lights up and the Program Service name appears on the display panel.

### Note

RDS may not work properly if the station you tuned to is not transmitting the RDS signal or if the signal strength is weak.

### Tip

While a Program Service name is displayed, you can check the frequency by pressing **DISPLAY** repeatedly (page 37).

## Enjoying Surround Sound

### Selecting the sound field

This receiver can create multi channel surround sound. You can select one of the optimized sound fields from the receiver's pre-programmed sound fields.

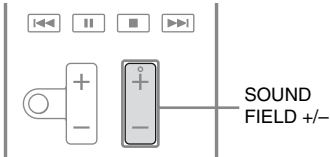

**Press SOUND FIELD +/- repeatedly to select the sound field you want.**

You can also press 2CH/A.DIRECT, A.F.D., MOVIE/HD-D.C.S. or MUSIC on the receiver.

#### 2 channel sound mode

You can switch the output sound to 2 channel sound regardless of the recording formats of the software you are using, the playback equipment connected, or the sound field settings of the receiver.

##### ■ 2CH ST. (2 Channel Stereo)

The receiver outputs the sound from the front left/right speakers only. There is no sound from the subwoofer.

Standard 2 channel stereo sources completely bypass the sound field processing and multi channel surround formats are downmixed to 2 channel except LFE signal.

##### ■ A. DIRECT (Analog Direct)

You can switch the audio of the selected input to 2 channel analog input. This function enables you to enjoy high quality analog sources without any adjustment.

When using this function, only the volume and front speaker level can be adjusted.

#### Note

You cannot select "A. DIRECT" when you select BD/DVD and GAME as input.

#### Auto Format Direct (A.F.D.) mode

The Auto Format Direct (A.F.D.) mode allows you to listen to high fidelity sound and select the decoding mode for listening to a 2 channel stereo sound as multi channel sound.

##### ■ A.F.D. AUTO (A.F.D. Auto)

Presets the sound as it was recorded/encoded without adding any surround effects.

However, for USA and Canada models, this receiver will generate a low frequency signal for output to the subwoofer when there is no LFE signals.

##### ■ MULTI ST. (Multi Stereo)

Outputs 2 channel left/right signals from all speakers. However, sound may not be output from certain speakers depending on the speaker settings.

#### Movie mode

You can take advantage of surround sound simply by selecting one of the receiver's pre-programmed sound fields. They bring the exciting and powerful sound of movie theaters into your home.

## ■ HD-D.C.S. (HD Digital Cinema Sound)

This mode is Sony's new innovative home theater technology using the latest acoustic and digital signal processing technologies. It is based on precise response measurement data of a mastering studio.

With this mode, you are able to enjoy Blu-ray and DVD movies at home with not only the high quality of sound, but also the best sound ambience, just as the movie's sound engineer intended in the mastering process.

You can select the effect type for HD-D.C.S. (page 58).

## ■ PLII MV (Pro Logic II Movie)

Performs Dolby Pro Logic II Movie mode decoding. This setting is ideal for movies encoded in Dolby Surround. In addition, this mode can reproduce sound in 5.1 channel for watching videos of overdubbed or old movies.

## ■ PLIIX MV (Pro Logic IIX Movie)

Performs Dolby Pro Logic IIX Movie mode decoding. This setting expands Dolby Pro Logic II Movie or Dolby Digital 5.1 to discrete 7.1 movie channels.

## ■ PLIIZ (Pro Logic IIZ)

Performs Dolby Pro Logic IIZ mode decoding. This setting increases flexibility to expand a 5.1 to a 7.1 channel system. Its vertical equipment gives a dimension of presence and depth.

## ■ NEO6 CIN (Neo:6 Cinema)

Performs DTS Neo:6 Cinema mode decoding. A source recorded in 2 channel format is decoded into 7 channels.

## Music mode

You can take advantage of surround sound simply by selecting one of the receiver's pre-programmed sound fields. They bring the exciting and powerful sound of concert halls into your home.

## ■ HALL (Hall)

Reproduces the acoustics of a classical concert hall.

## ■ JAZZ (Jazz Club)

Reproduces the acoustics of a jazz club.

## ■ CONCERT (Concert)

Reproduces the acoustics of a 300-seat live house.

## ■ STADIUM (Stadium)

Reproduces the feeling of a large open-air stadium.

## ■ SPORTS (Sports)

Reproduces the feeling of sports broadcasting.

## ■ P. AUDIO (Portable Audio Enhancer)

Reproduces a clear enhanced sound image from your portable audio device. This mode is ideal for MP3 and other compressed music.

## ■ PLII MS (Pro Logic II Music)

Perform Dolby Pro Logic II Music mode decoding. This setting is ideal for normal stereo sources such as CDs.

## ■ PLIIX MS (Pro Logic IIX Music)

Performs Dolby Pro Logic IIX Music mode decoding. This setting is ideal for normal stereo sources such as CDs.

## ■ PLIIZ (Pro Logic IIZ)

Performs Dolby Pro Logic IIZ mode decoding. This setting increases flexibility to expand a 5.1 to a 7.1 channel system. Its vertical equipment gives a dimension of presence and depth.

## ■ NEO6 MUS (Neo:6 Music)

Performs DTS Neo:6 Music mode decoding. A source recorded in 2 channel format is decoded into 7 channels. This setting is ideal for normal stereo sources such as CDs.

## When headphones are connected

You can only select the following sound fields if the headphones are connected to the receiver.

### ■ HP 2CH (Headphones 2CH)

This mode is selected automatically if you use headphones (except Analog Direct). Standard 2 channel stereo sources completely bypass the sound field processing and multi channel surround formats are downmixed to 2 channels except LFE signals.

### ■ HP DIR (Headphones Direct)

This mode is selected automatically if you use headphones and when "A. DIRECT" is selected.

Outputs the analog signals without processing by the equalizer, sound field, etc.

## If you connect a subwoofer

This receiver will generate a low frequency signal for output to the subwoofer when there is no LFE signal, which is a low-pass sound effect output from a subwoofer to a 2 channel signal. However, the low frequency signal is not generated for "NEO6 CIN" or "NEO6 MUS" when all speakers are set to "LARGE". In order to take full advantage of the Dolby Digital bass redirection circuitry, we recommend setting the subwoofer's cut off frequency as high as possible.

## Notes on sound fields

- Depends on the speaker pattern settings, some sound fields may not be available.
- The sound fields for music and movie do not work in the following cases.
  - DTS-HD Master Audio, DTS-HD High Resolution Audio or Dolby TrueHD with sampling frequency of more than 48 kHz are being received.
  - "A. DIRECT" is selected.

- "PLII MV", "PLIIX MV", "PLII MS", "PLIIX MS", "PLIIZ", "NEO6 CIN" and "NEO6 MUS" also do not work when the speaker pattern is set to 2/0 or 2/0.1.
- You cannot select "PLIIX" and "PLIIZ" at the same time.
  - "PLIIX" is available only when the speaker pattern is set to a setting with surround back speaker(s).
  - "PLIIZ" is available only when the speaker pattern is set to a setting with front high speakers.
- When one of the sound fields for music is selected, no sound is output from the subwoofer if all the speakers are set to "LARGE" in the SPEAKER menu. However, the sound will be output from the subwoofer if
  - the digital input signal contains LFE signals.
  - the front or surround speakers are set to "SMALL".
  - "MULTI ST.", "PLII MV", "PLII MS", "PLIIX MV", "PLIIX MS", "HD-D.C.S." or "P. AUDIO" is selected.

## To turn off the surround effect for movie/music

Press SOUND FIELD +/- repeatedly to select "2CH ST." or "A.F.D. AUTO".

You can also repeatedly press 2CH/A.DIRECT or press A.F.D on the receiver to select "2CH ST." or "A.F.D. AUTO" respectively.

## Digital audio formats supported by the receiver

Digital audio formats that this receiver can decode depend on digital audio output jacks of the connected equipment. This receiver supports the following audio formats.

Audio format	Maximum number of channels	Connection between the playback equipment and the receiver	
		COAXIAL/OPTICAL	HDMI
Dolby Digital	5.1	○	○
Dolby Digital EX	6.1	○	○
Dolby Digital Plus <sup>a)</sup>	7.1	×	○
Dolby TrueHD <sup>a)</sup>	7.1	×	○
DTS	5.1	○	○
DTS-ES	6.1	○	○
DTS 96/24	5.1	○	○
DTS-HD High Resolution Audio <sup>a)</sup>	7.1	×	○
DTS-HD Master Audio <sup>a)b)</sup>	7.1	×	○
Multi Channel Linear PCM <sup>a)</sup>	7.1	×	○

<sup>a)</sup> Audio signals are output in another format if the playback equipment does not correspond to the format. For details, refer to the operating instructions of the playback equipment.

<sup>b)</sup> Signals with a sampling frequency of more than 96 kHz are played back at 96 kHz or 88.2 kHz.

# Resetting sound fields to the default settings

Be sure to use the buttons on the receiver to perform this operation.

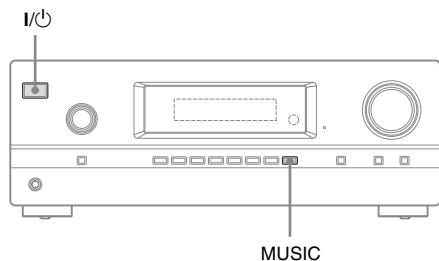

**1** Press I/Power to turn off the receiver.

**2** While holding down MUSIC, press I/Power.

“S.F. CLEAR” appears on the display panel and all sound fields are reset to their default setting.

## “BRAVIA” Sync Features

### What is “BRAVIA” Sync?

The “BRAVIA” Sync function allows communication between Sony products such as TV, Blu-ray Disc/DVD Player, AV amplifier, etc. that supports the Control for HDMI function.

By connecting Sony equipment that is compatible with the “BRAVIA” Sync with an HDMI cable (not supplied), operation is simplified as follows:

- One-Touch Play (page 49)
- System Audio Control (page 49)
- System Power-Off (page 50)
- Theater/Theatre Mode Sync (page 50)
- Scene Select (page 50)

Control for HDMI is a mutual control function standard used by HDMI CEC (Consumer Electronics Control) for HDMI (High-Definition Multimedia Interface).

We recommend that you connect the receiver to products featuring “BRAVIA” Sync.

#### Note

Depending on the connected equipment, the Control for HDMI function may not work. Refer to the operating instructions of the equipment.

## Preparing for the “BRAVIA” Sync

The receiver is compatible with the “Control for HDMI-Easy Setting” function.

- If your TV is compatible with the “Control for HDMI-Easy Setting” function, you can set the Control for HDMI function of the receiver and playback equipment automatically by setting the Control for HDMI function on your TV (page 48).
- If your TV is not compatible with the “Control for HDMI-Easy Setting” function, set the Control for HDMI function of the receiver, playback equipment and TV individually (page 48).

### If your TV is compatible with the “Control for HDMI-Easy Setting” function

- 1** Connect the receiver, TV and playback equipment via HDMI connection.  
(The respective equipment must be compatible with the Control for HDMI function.)
- 2** Turn on the receiver, TV and playback equipment.
- 3** Turn on the Control for HDMI function of the TV.  
The Control for HDMI function of the receiver and all the connected equipment are turned on simultaneously. When the setup is completed, “COMPLETE” will appear on the display panel.

For details on setting the TV, refer to the operating instructions supplied with the TV.

### If your TV is not compatible with the “Control for HDMI-Easy Setting” function

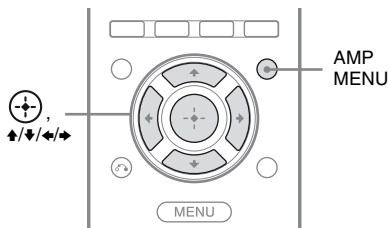

- 1** Press AMP MENU.
- 2** Press  $\uparrow/\downarrow$  repeatedly to select “HDMI”, then press  $\oplus$  or  $\rightarrow$ .
- 3** Press  $\uparrow/\downarrow$  repeatedly to select “CTRL.HDMI”, then press  $\oplus$  or  $\rightarrow$ .
- 4** Press  $\uparrow/\downarrow$  repeatedly to select “CTRL ON”, then press  $\oplus$ .  
Control for HDMI function is turned on.
- 5** Set the Control for HDMI function for the connected equipment to on.  
If the Control for HDMI function is already set to on, you do not need to change the setting.  
For details on setting the TV and connected equipment, refer to the operating instructions of the respective equipment.

#### Notes

- Before you perform the “Control for HDMI-Easy Setting” on your TV, be sure to turn on the TV and other connected equipment including the receiver first.
- If the playback equipment cannot function after you have made the settings for “Control for HDMI-Easy Setting”, check the Control for HDMI setting on your TV.
- If the connected equipment do not support the “Control for HDMI-Easy Setting”, but still supports the Control for HDMI then you need to set the Control for HDMI function for the connected equipment before you perform the “Control for HDMI-Easy Setting” from the TV.
- If you have assigned the HDMI input to another input using “H. ASSIGN” in HDMI menu, the One-Touch Play function is not available.

## Playing back equipment with one-touch operation (One-Touch Play)

By a simple operation (one-touch), equipment connected to the receiver with "BRAVIA" Sync function start automatically. You can enjoy the sound/image from connected equipment.

When you set "PASS.THROUGH" to "AUTO" or "ON", sound and image can be output only from the TV while the receiver remains in standby mode.

When you start playback a connected equipment, the receiver and TV operation are simplified as follow:

### Receiver and TV

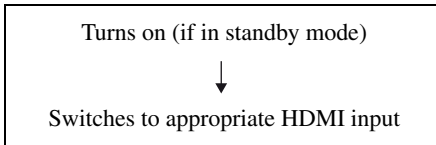

### Notes

- Depending on the TV, the start of the content may not appear.
- Depending on the settings, the receiver may not turn on when "PASS.THROUGH" is set to "AUTO" or "ON".
- Be sure that the System Audio Control function is set to on using TV menu.

### Tip

You can also select a connected equipment, such as Blu-ray Disc/DVD player from the TV menu. The receiver and TV will automatically switch to the appropriate HDMI input.

## Enjoying the TV sound from the speakers connected to the receiver (System Audio Control)

You can enjoy the TV sound from the speakers connected to the receiver by a simple operation.

You can operate System Audio Control function using the TV menu. For details, refer to the operating instructions of the TV.

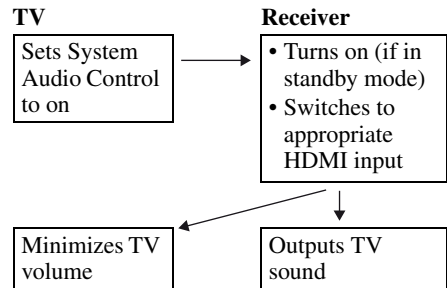

You can also use the System Audio Control function as follows.

- If you turn on the receiver while the TV is turned on, the System Audio Control function will automatically activate to output TV sound through the speakers connected to the receiver. However, if you turn off the receiver, the sound will output from the TV speakers.
- When you adjust the TV volume, the System Audio Control function adjusts the receiver's volume simultaneously.

### Notes

- If System Audio Control does not function according to your TV setting, refer to the operating instructions of the TV.
- When "CTRL.HDMI" is set to "CTRL ON", the "AUDIO.OUT" settings in the HDMI menu will set automatically based on the System Audio Control settings.
- Your TV must support the System Audio Control function.
- If the TV is turned on before turning on the receiver, the TV will momentarily lose the sound output.

## Turning off the receiver with the TV

### (System Power-Off)

When you turn the TV off, using the POWER button on the TV's remote control, the receiver and the connected equipment turn off automatically.

You can also use the receiver's remote control to turn off the TV.

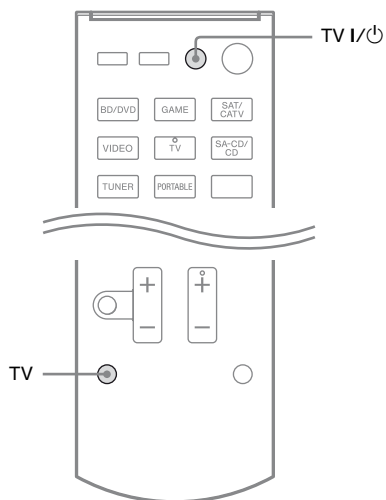

### Hold down TV, then press TV I/⏻.

The TV, receiver and the equipment connected via HDMI are turned off.

#### Notes

- Set the TV power supply interlock function to on before using the System Power-Off function. For details, refer to the operating instructions of the TV.
- Depending on the connected equipment, it may not be turned off. For details, refer to the operating instructions of the connected equipment.

## Enjoying movies with the optimum sound field

### (Theater/Theatre Mode Sync)

**Press the THEATER or THEATRE button on the remote control of the TV or the Blu-ray Disc player, while pointing the remote control toward the TV.**

The sound field switches to “HD-D.C.S.”.

To return to the previous sound field, press the THEATER or THEATRE button again.

#### Note

The sound field may not switch depending on the TV.

#### Tip

The sound field may revert to the previous field when you change the TV's input.

## Enjoying optimum sound field for the selected scene

### (Scene Select)

The Scene Select function allows you to enjoy the optimum picture quality and switches the sound field according to the selected scene on your TV. For details on the operation, refer to the operating instructions of the TV.

#### Note

The sound field may not switch depending on the TV.

# Switching between digital and analog audio (INPUT MODE)

When you connect equipment to both digital and analog audio input jacks on the receiver, you can fix the audio input mode to either of them, or switch from one to the other, depending on the type of material you intend to watch.

## 1 Press input button to select the input source.

You can also use the INPUT SELECTOR on the receiver.

## 2 Press INPUT MODE repeatedly.

The selected audio input mode appears on the display panel.

- **AUTO:** Gives priority to digital audio signals when there are both digital and analog connections.

If there are more than one digital connection, HDMI audio signals have priority.

If there are no digital audio signals, analog audio signals are selected.

When TV input is selected, priority is given to the Audio Return Channel (ARC) signals. If your TV is not compatible with the Audio Return Channel (ARC) function, the digital optical audio signals are selected.

- **COAX:** Specifies the digital audio signals input to the DIGITAL COAXIAL jack.
- **OPT:** Specifies the digital audio signals input to the DIGITAL OPTICAL jack.
- **ANALOG:** Specifies the analog audio signals input to the AUDIO IN (L/R) jacks.

## Notes

- Some audio input modes may not be set up based on the input.
- When “A. DIRECT” is being used, audio input is set to “ANALOG”. You cannot select other modes.
- The Audio Return Channel (ARC) function does not work in the following cases.
  - Your TV is not compatible with the Audio Return Channel (ARC) function.
  - “CTRL.HDMI” is set to “CTRL OFF”.
  - When you do not connect the receiver to the ARC compatible TV’s HDMI jack via an HDMI cable.

# Using the sound/images from other inputs

You can reassign the HDMI, COMPONENT VIDEO and DIGITAL input jacks to other input if the default settings of the jacks do not correspond to your connected equipment.

After you have reassigned the input jacks, you can use the input button (or INPUT SELECTOR on the receiver) to select the equipment you connected.

Example:

When you connect the DVD player to the OPTICAL SAT/CATV IN and COMPONENT VIDEO SAT/CATV (IN 2) jacks.

- Assign the OPTICAL SAT/CATV IN jack to “BD/DVD”
- Assign the COMPONENT VIDEO SAT/CATV (IN 2) jacks to “BD/DVD”

## Note

Before you reassign the HDMI input jacks, be sure to set “CTRL.HDMI” to “CTRL OFF”.

## 1 Press AMP MENU.

## 2 Press $\uparrow/\downarrow$ repeatedly to select “AUDIO”, “VIDEO” or “HDMI”, then press $\odot$ or $\rightarrow$ .

**3** Press  $\uparrow/\downarrow$  repeatedly to select “A. ASSIGN”, “V. ASSIGN” or “H. ASSIGN”, then press  $\odot$  or  $\rightarrow$ .

**4** Press  $\uparrow/\downarrow$  repeatedly to select the following setting, then press  $\odot$  or  $\rightarrow$ .

For “A. ASSIGN” and “V. ASSIGN”:  
Select input name you want to assign to.  
For “H. ASSIGN”:  
Select input jack you want to reassign.

**5** Press  $\uparrow/\downarrow$  repeatedly to select the following setting, then press  $\odot$ .

For “A. ASSIGN” and “V. ASSIGN”:  
Select input jack you want to reassign.  
For “H. ASSIGN”:  
Select input name you want to assign to.

**To return to the previous display**

Press  $\leftarrow$  or RETURN/EXIT  $\rightarrow$ .

## Assigning input jacks

Assignable input jacks		Input name						
		BD/DVD	GAME	SAT (SAT/CATV)	VIDEO	SA-CD (SA-CD/CD)	PORT (PORTABLE)	NONE
HDMI	HDMI 1	$\odot^*$	$\circ$	$\circ$	$\circ$	$\circ$	$\circ$	$\circ$
	HDMI 2	$\circ$	$\odot^*$	$\circ$	$\circ$	$\circ$	$\circ$	$\circ$
	HDMI 3	$\circ$	$\circ$	$\odot^*$	$\circ$	$\circ$	$\circ$	$\circ$
	HDMI 4	$\circ$	$\circ$	$\circ$	$\odot^*$	$\circ$	$\circ$	$\circ$
Video	CMPNT 1 (Component 1)	$\odot^*$	$\circ$	$\circ$	$\circ$	$\circ$	$\circ$	–
	CMPNT 2 (Component 2)	$\circ$	$\circ$	$\odot^*$	$\circ$	$\circ$	$\circ$	–
	COMP (Composite)	–	–	$\circ$	$\odot^*$	–	–	–
	NONE	$\circ$	$\odot^*$	–	–	$\odot^*$	$\odot^*$	–
Audio	SAT OPT	$\circ$	$\circ$	$\odot^*$	$\circ$	$\circ$	$\circ$	–
	BD COAX	$\odot^*$	$\circ$	$\circ$	$\circ$	$\circ$	$\circ$	–
	ANALOG	–	–	$\circ$	$\odot^*$	$\odot^*$	$\odot^*$	–
	NONE	–	$\odot^*$	–	–	–	–	–

\* Default setting

### Notes

- When you reassign the HDMI or DIGITAL audio input jacks, the INPUT MODE setting may change automatically (page 51).
- One reassignment is allowed for each input.

# Using the setting menu

You can customize the receiver by making various adjustments with settings menu.

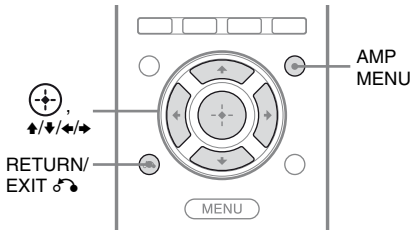

- 1 Press AMP MENU.**
- 2 Press  $\uparrow/\downarrow$  repeatedly to select the menu item you want, then press  $\ominus$  or  $\rightarrow$ .**
- 3 Press  $\uparrow/\downarrow$  repeatedly to select the parameter you want to adjust, then press  $\oplus$  or  $\rightarrow$ .**
- 4 Press  $\uparrow/\downarrow$  repeatedly to select the setting you want, then press  $\ominus$ .**

## To return to the previous display

Press  $\leftarrow$  or RETURN/EXIT  $\leftarrow$ .

## To exit the menu

Press AMP MENU.

### Note

Some parameters and settings may appear dimmed on the display panel. This means that they are either unavailable or fixed and unchangeable.

## Overview of the menus

The following options are available in each menu. For details, see the referencing page in the parentheses.

Menu [Display]	Parameters [Display]	Settings	Default setting
AUTO CAL <sup>a)</sup> [A. CAL] (page 31)	Auto Calibration (Standard) [STANDARD]		
	Auto Calibration (Custom) [CUSTOM]	FULL.FLAT, ENGINEER FRONT.REF, OFF	ENGINEER
LEVEL [LEVEL] (page 57)	Test tone <sup>b)</sup> [T. TONE]	OFF, AUTO ■■■ <sup>c)</sup>	OFF
	Front left speaker level <sup>b)</sup> [FL LVL]	FL -10.0 dB to FL +10.0 dB (0.5 dB interval)	FL 0 dB
	Front right speaker level <sup>b)</sup> [FR LVL]	FR -10.0 dB to FR +10.0 dB (0.5 dB interval)	FR 0 dB
	Center speaker level <sup>b)</sup> [CNT LVL]	CNT -10.0 dB to CNT +10.0 dB (0.5 dB interval)	CNT 0 dB
	Surround left speaker level <sup>b)</sup> [SL LVL]	SL -10.0 dB to SL +10.0 dB (0.5 dB interval)	SL 0 dB
	Surround right speaker level <sup>b)</sup> [SR LVL]	SR -10.0 dB to SR +10.0 dB (0.5 dB interval)	SR 0 dB
	Surround back speaker level <sup>b)</sup> [SB LVL]	SB -10.0 dB to SB +10.0 dB (0.5 dB interval)	SB 0 dB
	Surround back left speaker level <sup>b)</sup> [SBL LVL]	SBL -10.0 dB to SBL +10.0 dB (0.5 dB interval)	SBL 0 dB
	Surround back right speaker level <sup>b)</sup> [SBR LVL]	SBR -10.0 dB to SBR +10.0 dB (0.5 dB interval)	SBR 0 dB
	Front left high speaker level <sup>b)</sup> [LH LVL]	LH -10.0 dB to LH +10.0 dB (0.5 dB interval)	LH 0 dB
	Front right high speaker level <sup>b)</sup> [RH LVL]	RH -10.0 dB to RH +10.0 dB (0.5 dB interval)	RH 0 dB
	Subwoofer level <sup>b)</sup> [SW LVL]	SW -10.0 dB to SW +10.0 dB (0.5 dB interval)	SW 0 dB
	Dynamic range compressor [D. RANGE]	COMP. MAX, COMP. STD, COMP.AUTO, COMP. OFF	COMP.AUTO
	SPEAKER [SPKR] (page 57)	Speaker pattern [PATTERN]	For details, see page 30.
Front speakers size <sup>b)</sup> [FRT SIZE]		LARGE, SMALL	LARGE
Center speaker size <sup>b)</sup> [CNT SIZE]		LARGE, SMALL	LARGE

Menu [Display]	Parameters [Display]	Settings	Default setting
	Surround speakers size <sup>b)</sup> [SUR SIZE]	LARGE, SMALL	LARGE
	Front high speakers size <sup>b)</sup> [FH SIZE]	LARGE, SMALL	LARGE
	Front left speaker distance <sup>b)</sup> [FL DIST.]		
	Front right speaker distance <sup>b)</sup> [FR DIST.]		
	Center speaker distance <sup>b)</sup> [CNT DIST.]		
	Surround left speaker distance <sup>b)</sup> [SL DIST.]		
	Surround right speaker distance <sup>b)</sup> [SR DIST.]		
	Surround back speaker distance <sup>b)</sup> [SB DIST.]	1.00 m to 10.00 m (0.1 m interval) <sup>d)</sup> 3'3" to 32'9" (1 inch interval)	3.00 m 9'10"
	Surround back left speaker distance <sup>b)</sup> [SBL DIST.]		
	Surround back right speaker distance <sup>b)</sup> [SBR DIST.]		
	Front left high speaker distance <sup>b)</sup> [LH DIST.]		
	Front right high speaker distance <sup>b)</sup> [RH DIST.]		
	Subwoofer distance <sup>b)</sup> [SW DIST.]		
	Distance unit [DIST.UNIT]	METER, FEET	METER <sup>e)</sup>
	Front speakers crossover frequency <sup>f)</sup> [FRT CRS.]	CRS. 40 Hz to CRS. 200 Hz (10 Hz interval)	CRS. 120 Hz
	Center speaker crossover frequency <sup>f)</sup> [CNT CRS.]	CRS. 40 Hz to CRS. 200 Hz (10 Hz interval)	CRS. 120 Hz
	Surround speakers crossover frequency <sup>f)</sup> [SUR CRS.]	CRS. 40 Hz to CRS. 200 Hz (10 Hz interval)	CRS. 120 Hz
	Front high speakers crossover frequency <sup>f)</sup> [FH CRS.]	CRS. 40 Hz to CRS. 200 Hz (10 Hz interval)	CRS. 120 Hz
SURROUND [SURR] (page 58)	HD-D.C.S. effect type [EFFECT]	DYNAMIC, THEATER, STUDIO	THEATER

continued

<b>Menu [Display]</b>	<b>Parameters [Display]</b>	<b>Settings</b>	<b>Default setting</b>
EQ [EQ] (page 59)	Front speakers bass level [BASS]	BASS -10 dB to BASS +10 dB (1 dB interval)	BASS 0 dB
	Front speakers treble level [TREBLE]	TRE -10 dB to TRE +10 dB (1 dB interval)	TRE 0 dB
TUNER [TUNER] (page 59)	FM station receiving mode [FM MODE]	STEREO, MONO	STEREO
	Naming preset stations [NAME IN]	For details, see “Naming preset stations” (page 42).	
AUDIO [AUDIO] (page 59)	Synchronizes audio with video output [A/V SYNC]	SYNC ON, SYNC OFF	SYNC OFF
	Digital broadcast language selection [DUAL]	MAIN/SUB, MAIN, SUB	MAIN
	Digital audio input assignment [A. ASSIGN]	For details, see “Using the sound/ images from other inputs” (page 51).	
	Night mode [NIGHT M.]	NIGHT. ON, NIGHT.OFF	NIGHT.OFF
VIDEO [VIDEO] (page 59)	Video input assignment [V. ASSIGN]	For details, see “Using the sound/ images from other inputs” (page 51).	
HDMI [HDMI] (page 60)	Control for HDMI [CTRL.HDMI]	CTRL ON, CTRL OFF	CTRL ON
	HDMI Signal Pass Through [PASS.THROUGH]	ON, AUTO, OFF	OFF
	Setting HDMI audio input [AUDIO.OUT]	AMP, TV+AMP	AMP
	HDMI input assignment [H. ASSIGN]	For details, see “Using the sound/ images from other inputs” (page 51).	
SYSTEM [SYSTEM] (page 60)	Auto standby mode [AUTO.STBY]	STBY ON, STBY OFF	STBY ON
	Naming inputs [NAME IN]	For details, see “Naming inputs” (page 37).	

a) Europe, Australia and Taiwan models only.

b) Depends on the speaker pattern setting, some parameters may not be available.

c) ■■■ represent a speaker channel (FL, FR, CNT, SL, SR, SB, SBL, SBR, LH, RH, SW).

d) You can only adjust the distance in 0.01 meter interval when you have performed the Auto Calibration and saved the measurement result.

e) “FEET” for USA and Canada models.

f) You cannot select this setting if your speaker is set to “LARGE”.

## LEVEL menu

You can adjust the level of each speaker manually.

### ■ T. TONE

Lets you adjust the speaker levels while listening to the test tone from your seating position (page 35).

### ■ FL LVL, FR LVL, CNT LVL, SL LVL, SR LVL, SB LVL, SBL LVL, SBR LVL, LH LVL, RH LVL, SW LVL

You can adjust each speaker's level (front left/right, center, surround left/right, surround back left/right, front left/right high, subwoofer).

#### Note

Depends on the speaker pattern setting, some parameters may not be available.

### ■ D. RANGE

Lets you compress the dynamic range of the soundtrack. This may be useful when you want to watch movies at low volumes late at night. Dynamic range compression is possible with Dolby Digital sources only.

- COMP. MAX  
The dynamic range is compressed dramatically.
- COMP. STD  
The dynamic range is compressed as intended by the recording engineer.
- COMP. AUTO  
The dynamic range is compressed automatically.
- COMP. OFF  
The dynamic range is not compressed.

### Tip

Dynamic range compressor lets you compress the dynamic range of the soundtrack based on the dynamic range information included in the Dolby Digital signal.

“COMP. STD” is the standard setting, and enacts light compression. Therefore, we recommend using the “COMP. MAX” setting. This greatly compresses the dynamic range and lets you view movies late at night at low volumes. Unlike analog limiters, the levels are predetermined and provide a very natural compression.

## SPEAKER menu

You can adjust the size and distance of the speakers connected to this receiver.

### ■ PATTERN

Lets you select the speaker pattern according to the speaker system which you are using (page 30).

### ■ FRT SIZE, CNT SIZE, SUR SIZE, FH SIZE

You can adjust each speaker's size (front left/right, center, surround left/right, surround back left/right, front left/right high).

- LARGE  
If you connect large speakers that will effectively reproduce bass frequencies, select “LARGE”. Normally, select “LARGE”.
- SMALL  
If the sound is distorted, or you feel a lack of surround effects when using multi channel surround sound, select “SMALL” to activate the bass redirection circuitry and output the bass frequencies of each channel from the subwoofer or other “LARGE” speakers.

#### Note

This function does not work when “A. DIRECT” is selected.

## Tips

- The “LARGE” and “SMALL” settings for each speaker determine whether the internal sound processor will cut the bass signal from that channel.

When the bass is cut from a channel, the bass redirection circuitry sends the corresponding bass frequencies to the subwoofer or other “LARGE” speakers.

However, since bass sounds have a certain amount of directionality, it is best not to cut them, if possible. Therefore, even when using small speakers, you can set them to “LARGE” if you want to output the bass frequencies from that speaker. On the other hand, if you are using a large speaker, but prefer not to have bass frequencies output from that speaker, set it to “SMALL”.

If the overall sound level is lower than you prefer, set all speakers to “LARGE”. If there is not enough bass, you can use the equalizer to boost the bass levels. For details, see page 59.

- The surround back speakers will be set to the same setting as that of the surround speakers.
- When the front speakers are set to “SMALL”, the center, surround, and front high speakers are also automatically set to “SMALL”.
- If you do not use the subwoofer, the front speakers are automatically set to “LARGE”.

## ■ FL DIST., FR DIST., CNT DIST., SL DIST., SR DIST., SB DIST., SBL DIST., SBR DIST., LH DIST., RH DIST., SW DIST.

Lets you adjust the distance from your seating position to each speaker (front left/right, center, surround left/right, surround back left/right, front left/right high, subwoofer).

If both front speakers are not placed in equal distance from your seating position, set the distance to the closest speaker.

## Notes

- Depends on the speaker pattern setting, some parameters may not be available.
- This function does not work when “A. DIRECT” is selected.

## ■ DIST.UNIT

Lets you select the unit of measure for setting distances.

- METER  
The distance is displayed in meters.
- FEET  
The distance is displayed in feet.

## ■ FRT CRS., CNT CRS., SUR CRS., FH CRS.

Lets you set the bass crossover frequency of the speakers that have been set to “SMALL” in the SPEAKER menu.

## SURROUND menu

### ■ EFFECT

Lets you select the effect type for “HD-D.C.S.”. Each effect type has different reflection and reverberation sound mixture levels and is optimized to match a listener’s room uniqueness, taste and mood.

- DYNAMIC  
Want to enjoy the sound effects to the full extent, just like at the movie theaters? DYNAMIC type emphasizes on the reflection sound. Without HD-D.C.S., many rooms are often somewhat reverberant but lack a spacious feeling. This type acoustically opens up those types of rooms and provides a spacious and dynamism feeling equivalent to a mastering studio.
- THEATER  
THEATER type mixes reflection and reverberation sound creating the characteristics of a mastering studio. Additionally, this type mixes in frequency characteristics that are often found in professional studios and movie theaters. It is ideal for watching movies in a listening room that has less reverberation.
- STUDIO  
In STUDIO type, effects are kept to a minimum, while still providing a great theater experience. This type provides the accuracy of the original recording.

## EQ menu

You can adjust the tonal quality (bass/treble level) of the front speakers.

### ■ BASS

### ■ TREBLE

#### Note

This function does not work when “A. DIRECT” is selected.

## TUNER menu

You can set the FM station receiving mode and name the preset stations.

### ■ FM MODE

#### • STEREO

This receiver will decode the signal as stereo signal when the radio station is broadcast in stereo.

#### • MONO

This receiver will decode the signal as mono signal regardless of the broadcast signal.

### ■ NAME IN

Lets you set the name of preset stations. For details, see “Naming preset stations” (page 42).

## AUDIO menu

You can adjust settings for the audio to suit your preference.

### ■ A/V SYNC

Lets you delay the output of audio to minimize the time gap between audio output and visual display.

#### • SYNC ON (Delay time: 60 ms)

The audio output is delayed so that the time gap between the audio output and visual display is minimized.

#### • SYNC OFF (Delay time: 0 ms)

The audio output is not delayed.

### Notes

- This parameter is useful when you use a large LCD or plasma monitor or a projector.
- This function does not work when “A. DIRECT” is selected.
- The delay time may vary depending on audio format, sound field, speaker pattern and speaker distance settings.

### ■ DUAL

Lets you select the language you want to listen to during digital broadcast when available. This feature only functions for Dolby Digital sources.

#### • MAIN/SUB

Sound of the main language will be output through the front left speaker and sound of the sub language will be output through the front right speaker simultaneously.

#### • MAIN

Sound of the main language will be output.

#### • SUB

Sound of the sub language will be output.

### ■ A. ASSIGN

Lets you reassign the DIGITAL audio input jack to other input source. For details, see “Using the sound/images from other inputs” (page 51).

### ■ NIGHT M.

Lets you retain a theater-like environment at low volume levels (page 13).

#### • NIGHT. ON

#### • NIGHT.OFF

## VIDEO menu

### ■ V. ASSIGN

Lets you reassign the COMPONENT VIDEO input jack to other input source. For details, see “Using the sound/images from other inputs” (page 51).

## HDMI menu

You can make the required settings for equipment connected to the HDMI jack.

### ■ CTRL.HDMI

Lets you turn the Control for HDMI function on or off. For details, see ““BRAVIA” Sync Features” (page 47).

### ■ PASS.THRU

Lets you output the HDMI signals to the TV even when the receiver is in standby mode.

- ON

When the receiver is in the standby mode, the receiver continuously outputs HDMI signals from the receiver’s HDMI TV OUT jack.

- AUTO

When the TV is turned on while the receiver is in the standby mode, the receiver outputs HDMI signals from the receiver’s HDMI TV OUT jack. Sony recommends this setting if you use a “BRAVIA” Sync compatible Sony TV. This setting saves power in the standby mode when compared with the “ON” setting.

- OFF

The receiver does not output HDMI signals when in the standby mode. Turn on the receiver to enjoy the connected equipment’s source on the TV. This setting saves power in the standby mode when compared with the “ON” setting.

### Notes

- This parameter is not available when “CTRL.HDMI” is set to “CTRL OFF”.
- When “AUTO” is selected, it may take a little more time for the image and sound to be output to the TV than when “ON” is selected.
- When the receiver is in standby mode, “A.STANDBY” appears on the display if “PASS.THRU” is set to “AUTO” or “ON”. However, “A.STANDBY” will disappear when “PASS.THRU” is set to “AUTO” and no signals are detected.

## ■ AUDIO.OUT

Lets you set the HDMI audio output from the playback equipment connected to the receiver via an HDMI connection.

- AMP

The HDMI audio signals from the playback equipment are only output to the speakers connected to the receiver. Multi channel sound can be played back as it is.

- TV+AMP

The sound is output from TV’s speaker and the speakers connected to the receiver.

### Notes

- The sound quality of the playback equipment depends on the TV’s sound quality, such as the number of channels, and the sampling frequency, etc. If the TV has stereo speakers, the sound output from the receiver is also in stereo as that of the TV, even if you play back multi channel source.
- When you connect the receiver to an image display equipment (projector, etc.), sound may not be output from the receiver. In this case, select “AMP”.

## ■ H. ASSIGN

Lets you reassign the HDMI input jack to other input source. For details, see “Using the sound/images from other inputs” (page 51).

## SYSTEM menu

You can customize the settings of the receiver.

### ■ AUTO.STBY

Lets you set the receiver switch to standby mode automatically when you do not operate the receiver or when there is no signals input to the receiver.

- STBY ON

Switches to standby mode after approximately 30 minutes.

- STBY OFF

Does not switch to standby mode.

## Notes

- This function does not work when TUNER input is selected.
- If you use the Auto standby mode and the Sleep Timer at the same time, the Sleep Timer has priority.

## ■ NAME IN

Lets you set the name of inputs. For details, see “Naming inputs” (page 37).

## Using the Remote Control

### Reassigning the input button

You can change the default settings of the input buttons to suit the equipment in your system. For example, if you connect a Blu-ray Disc player to the SAT/CATV jack on the receiver, you can set the SAT/CATV button on this remote control to control the Blu-ray Disc player.

#### Note

You cannot reassign the TV, TUNER and PORTABLE input buttons.

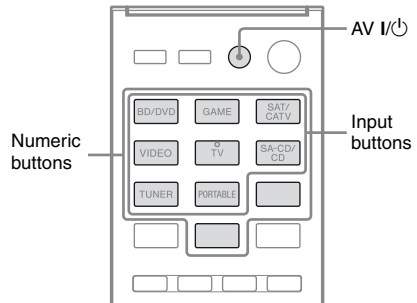

- 1 While holding down the input button of which you want to change the assignment, hold down AV I/O.**

Example: While holding down SAT/CATV, hold down AV I/O.

- 2 With the AV I/O button held, release the input button.**

Example: With the AV I/O button held, release SAT/CATV.

### 3 Referring to the following table, press the corresponding button for the category you want, then release AV I/⏻.

Example: Press 1, then release AV I/⏻. Now you can use the SAT/CATV button to control the Blu-ray Disc player.

Categories	Press
Blu-ray Disc player (command mode BD1) <sup>a)</sup>	1
Blu-ray Disc recorder (command mode BD3) <sup>a)</sup>	2
DVD player (command mode DVD1)	3
DVD recorder (command mode DVD3) <sup>b)</sup>	4
VCR (command mode VTR3) <sup>c)</sup>	5
CD player	6
DSS (Digital Satellite Receiver)/Euro Digital Satellite Receiver	7

<sup>a)</sup>For details on the BD1 or BD3 setting, refer to the operating instructions supplied with the Blu-ray Disc player or Blu-ray Disc recorder.

<sup>b)</sup>Sony DVD recorders are operated with a DVD1 or DVD3 setting. For details, refer to the operating instructions supplied with the DVD recorders.

<sup>c)</sup>Sony VCRs are operated with a VTR 3 setting which corresponds to VHS.

## Resetting the input buttons

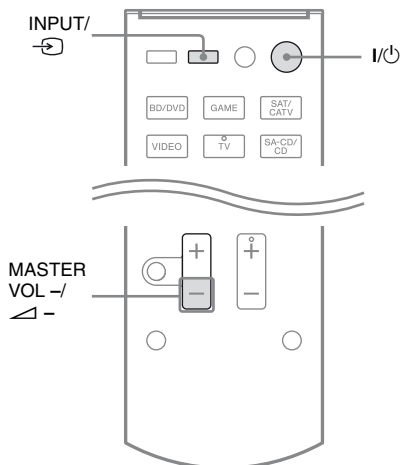

**1** While holding down **MASTER VOL -/ ▽ -**, press **I/⏻** and **INPUT/↵**.

**2** Release all buttons.

The input buttons are reset to the default setting.

# Precautions

## On safety

Should any solid object or liquid fall into the cabinet, unplug the receiver and have it checked by qualified personnel before operating it any further.

## On power sources

- Before operating the receiver, check that the operating voltage is identical with your local power supply.

The operating voltage is indicated on the nameplate on the back of the receiver.

- The unit is not disconnected from the AC power source (mains) as long as it is connected to the wall outlet, even if the unit itself has been turned off.
- If you are not going to use the receiver for a long time, be sure to disconnect the receiver from the wall outlet. To disconnect the AC power cord (mains lead), grasp the plug itself; never pull the cord.
- The AC power cord (mains lead) must be changed only at a qualified service shop.
- (USA and Canada models only)  
One blade of the plug is wider than the other for the purpose of safety and will fit into the wall outlet only one way. If you are unable to insert the plug fully into the outlet, contact your dealer.

## On heat buildup

Although the receiver heats up during operation, this is not a malfunction. If you continuously use this receiver at a large volume, the cabinet temperature of the top, side and bottom rises considerably. To avoid burning yourself, do not touch the cabinet.

## On placement

- Place the receiver in a location with adequate ventilation to prevent heat buildup and prolong the life of the receiver.
- Do not place the receiver near heat sources, or in a place subject to direct sunlight, excessive dust, or mechanical shock.
- Do not place anything on top of the cabinet that might block the ventilation holes and cause malfunctions.
- Do not place the receiver near equipment such as a TV, VCR, or tape deck. (If the receiver is being used in combination with a TV, VCR, or tape deck, and is placed too close to that equipment, noise may result, and picture quality may suffer. This is especially likely when using an indoor antenna (aerial). Therefore, we recommend using an outdoor antenna (aerial).)
- Use caution when placing the receiver on surfaces that have been specially treated (with wax, oil, polish, etc.) as staining or discoloration of the surface may result.

## On operation

Before connecting other equipment, be sure to turn off and unplug the receiver.

## On cleaning

Clean the cabinet, panel, and controls with a soft cloth slightly moistened with a mild detergent solution. Do not use any type of abrasive pad, scouring powder, or solvent, such as alcohol or benzine.

If you have any questions or problems concerning your receiver, please consult your nearest Sony dealer.

---

# Troubleshooting

If you experience any of the following difficulties while using the receiver, use this troubleshooting guide to help you remedy the problem. Should any problem persist, consult your nearest Sony dealer. Note that if service personnel changes some parts during repair, these parts may be retained.

---

## Power

---

### The receiver is turned off automatically.

- “AUTO.STBY” is set to “STBY ON” (page 60).
  - The Sleep Timer function is working (page 13).
- 

---

## Sound

---

### Dolby Digital or DTS multi channel sound is not reproduced.

- Check that the DVD, etc. you are playing is recorded in Dolby Digital or DTS format.
  - When connecting the DVD player, etc., to the digital input jacks of this receiver, make sure the digital audio output setting of the connected equipment is available.
  - Set “AUDIO.OUT” to “AMP” in the HDMI menu.
- 

---

### The surround effect cannot be obtained.

- Make sure you have selected the sound field for movie or music mode (page 43).
- Sound fields do not function when DTS-HD Master Audio, DTS-HD High Resolution Audio or Dolby TrueHD with sampling frequency of more than 48 kHz are being received.

---

### There is no sound, or only a very low-level sound is heard from specific speakers.

- Connect a pair of headphones to the PHONES jack to verify that sound is output from the headphones. If only one channel is output from the headphones, the equipment may not be connected to the receiver correctly. Check that all the cords are fully inserted into the jacks on both the receiver and the equipment. If both channels are output from the headphones, the front speaker may not be connected to the receiver correctly. Check the connection of the front speaker which is not outputting any sound.
- Make sure you have connected to both the L and R jacks of an analog equipment, analog equipment requires both L and R jack connections. Use an audio cord (not supplied).
- Check that the speaker settings are appropriate for the setup using the AUTO CAL menu\* or “PATTERN” in the SPEAKER menu. Then check that sound is output from each speaker correctly, using “T. TONE” in the LEVEL menu (page 35).
- Adjust the speaker level (page 54).
- Check that the subwoofer is connected correctly and securely.
- Make sure you have turned on your subwoofer.
- Depending on the selected sound field, no sound will be available from the subwoofer.
- When all speakers are set to “LARGE” and “NEO6 CIN” or “NEO6 MUS” is selected, there is no sound from the subwoofer.
- Some discs have no Dolby Digital Surround EX flag even though the packages have Dolby Digital Surround EX logos.

\*Europe, Australia and Taiwan models only.

---

**There is no sound from a specific equipment.**

- Check that the equipment is connected correctly to the audio input jacks for that equipment.
- Check that the cord(s) used for the connection is (are) fully inserted into the jacks on both the receiver and the equipment.
- Check the setting of “AUDIO.OUT” in the HDMI menu (page 60).
- Check that the equipment is connected correctly to the HDMI jack for that equipment.
- You cannot listen to the Super Audio CD by connecting HDMI.
- Depending on the playback equipment, you may need to set up the HDMI setting of the equipment. Refer to the operating instructions supplied with each equipment.
- Be sure to use a High Speed HDMI cable when you view images or listen to sound, especially for the 1080p, Deep Color (Deep Colour) or 3D transmission.
- Check the INPUT MODE (page 51).
- Check that the “A. DIRECT” is not selected.
- Check that the selected digital audio input jack is not reassigned to other inputs (page 51).

---

**There is no sound, no matter which equipment is selected, or only a very low-level sound is heard.**

- Check that all connecting cords are inserted to their input/output jacks for the respective jacks of the receiver, speakers and the equipment.
- Check that both the receiver and all equipment are turned on.
- Check that MASTER VOLUME is not set to “VOL MIN”.
- Check that headphones are not connected.
- Press MUTING or  on the remote control to cancel the muting function.

- Try pressing the input button on the remote control or turning INPUT SELECTOR on the receiver to select the equipment of your choice (page 36).
- The protective device on the receiver has been activated. Turn off the receiver, eliminate the short-circuit problem, and turn on the power again.

---

**There is severe hum or noise.**

- Check that the speakers and equipment are connected securely.
- Check that the connecting cords are away from a transformer or motor, and at least 3 meters (10 feet) away from a TV set or fluorescent light.
- Move your audio equipment away from the TV.
- The plugs and jacks are dirty. Wipe them with a cloth slightly moistened with alcohol.

---

**The left and right sounds are unbalanced or reversed.**

- Check that the speakers and equipment are connected correctly and securely.
- Adjust the level parameters using the LEVEL menu.

---

**When the receiver is in standby mode, there is no sound output from the TV.**

- When the receiver enters into standby mode, sound are from the last HDMI equipment selection before you turned off the receiver. If you are enjoying other equipment, play the equipment and perform the One-Touch Play operation, or turn on the receiver to select the HDMI equipment you want to enjoy.
- Make sure “PASS.THROUGH” is set to “ON” in the HDMI menu if you connect equipment not compatible with the “BRAVIA” Sync to the receiver (page 60).

---

**No sound is output from the receiver and TV speaker.**

- Check the setting of “AUDIO.OUT” in the HDMI menu (page 60).
- Check that the equipment is connected correctly to the HDMI jack for that equipment.
- You cannot listen to the Super Audio CD by connecting HDMI.
- Depending on the playback equipment, you may need to set up the HDMI setting of the equipment. Refer to the operating instructions supplied with each equipment.
- Be sure to use a High Speed HDMI cable when you view images or listen to sound, especially for the 1080p, Deep Color (Deep Colour) or 3D transmission.
- Make sure the TV is compatible with the System Audio Control function.
- If the TV does not have System Audio Control function, set the “AUDIO.OUT” settings in HDMI menu to
  - “TV+AMP” if you want to listen to the sound from the TV speaker and receiver.
  - “AMP” if you want to listen to the sound from the receiver.
- When you connect the receiver to a video equipment (projector, etc.), sound may not be output from the receiver. In this case, select “AMP”.
- If you cannot listen to the sound of the equipment connected to the receiver while TV input is selected
  - Be sure to change the input of the receiver to HDMI when you want to watch a program on the equipment connected via HDMI connection to the receiver.
  - Change the TV channel when you want to watch a TV broadcast.
  - Be sure to select the correct equipment or input you want when you watch a program from the equipment connected to the TV. Refer to the operating instructions of the TV on this operation.

---

**There is severe hum, interrupted noise or distortion from the equipment connected to the PORTABLE IN jack.**

- Check that the equipment are connected securely.
  - This is not a malfunction and will depend on the connected equipment.
- 

## Image

---

**No image appears on the TV.**

- Select the appropriate input using the input buttons.
- Set your TV to the appropriate input mode.
- Move your audio equipment away from the TV.
- Assign the HDMI and COMPONENT VIDEO input jacks correctly.
- Make sure that cables are correctly and securely connected to equipment.
- Depending on the playback equipment, you may need to set up the equipment. Refer to the operating instructions supplied with each equipment.
- Be sure to use a High Speed HDMI cable when you view images or listen to sound, especially for the 1080p, Deep Color (Deep Colour) or 3D transmission.

---

**No 3D image appears on the TV.**

- Depending on the TV or the video equipment, 3D images may not be displayed.

---

**When the receiver is in standby mode, there is no image output from the TV.**

- When the receiver enters into standby mode, image are from the last HDMI equipment selection before you turned off the receiver. If you are enjoying other equipment, play the equipment and perform the One-Touch Play operation, or turn on the receiver to select the HDMI equipment you want to enjoy.
- Make sure “PASS.THROUGH” is set to “ON” in the HDMI menu if you connect equipment not compatible with the “BRAVIA” Sync to the receiver (page 60).

---

**Recording cannot be carried out.**

- Check that the equipment are connected correctly.
- Select the source equipment using the input buttons (page 36).

---

## Tuner

---

**The FM reception is poor.**

- Use a 75-ohm coaxial cable (not supplied) to connect the receiver to an outdoor FM antenna (aerial) as shown below.

Outdoor FM antenna (aerial)

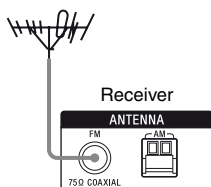

---

**Radio stations cannot be tuned in.**

- Check that the antennas (aerials) are connected securely. Adjust the antennas (aerials) and connect an external antenna (aerial), if necessary.
- The signal strength of the stations is too weak with automatic tuning. Use direct tuning.
- Make sure you set the tuning scale correctly (when tuning in AM stations with direct tuning) (page 40).
- No stations have been preset or the preset stations have been cleared (when tuning by scanning preset stations is used). Preset the stations (page 41).
- Press DISPLAY repeatedly so that the frequency appears on the display panel.

---

**RDS does not work.\***

- Make sure that you are tuned to an FM RDS station.
- Select a stronger FM station.

---

**The RDS information that you want does not appear.\***

- The service may be temporarily out of order. Contact the radio station and find out whether they actually provide the service in question.

---

\* Europe, Australia and Taiwan models only.

---

## Remote control

---

**The remote control does not function.**

- Point the remote control at the remote control sensor on the receiver.
- Remove any obstacles in the path between the remote control and the receiver.
- Replace all the batteries in the remote control with new ones, if they are weak.
- Make sure you select the correct input on the remote control.

## Other

### **The Control for HDMI function does not work.**

- Check the HDMI connection (page 21, 22).
- Make sure “CTRL.HDMI” is set to “CTRL ON” in the HDMI menu.
- Make sure the connected equipment is compatible with the Control for HDMI function.
- Check the Control for HDMI settings on the connected equipment. Refer to the operating instructions of the connected equipment.
- When “CTRL.HDMI” is set to “CTRL OFF”, the “BRAVIA” Sync does not work properly, even if a equipment is connected to the HDMI IN jack.
- The types and the number of equipment which can be controlled by the “BRAVIA” Sync are restricted in the HDMI CEC standard as follows.
  - Recording equipment (Blu-ray Disc recorder, DVD recorder, etc.): up to 3 equipment
  - Playback equipment (Blu-ray Disc player, DVD player, etc.): up to 3 equipment
  - Tuner-related equipment: up to 4 equipment
  - AV receiver (audio system): up to 1 equipment

### **The TV’s remote control cannot be used to control the connected equipment when using the Control for HDMI function.**

- Depending on the connected equipment and TV, you may need to set up the equipment and TV. Refer to the operating instructions supplied with each equipment and TV.
- Change the input of the receiver to the HDMI input connected to the equipment.

## Error messages

If there is a malfunction, a message appears on the display panel. You can check the condition of the system by the message. If any problem persists, consult your nearest Sony dealer. If an error message appears while you perform Auto Calibration, see “When error codes appear” (page 34) to solve the problem.

### **PROTECT**

Irregular current is output to the speakers, or the receiver is covered and ventilation holes are blocked. The receiver will automatically turn off after a few seconds. Check the speaker connection and turn on the power again.

## Clearing the memory

### **Reference sections**

<b>To clear</b>	<b>See</b>
All memorized settings	page 29
Customized sound fields	page 47

# Specifications

## AUDIO POWER SPECIFICATIONS

### POWER OUTPUT AND TOTAL HARMONIC DISTORTION: (USA model only)

With 8 ohm loads, both channels driven, from 20 – 20,000 Hz; rated 90 watts per channel minimum RMS power, with no more than 0.09% total harmonic distortion from 250 milliwatts to rated output.

#### Amplifier section

USA model<sup>1)</sup>

Minimum RMS Output Power  
(8 ohms, 20 Hz – 20 kHz, THD 0.09%)  
90 W + 90 W

Stereo Mode Output Power  
(8 ohms, 1 kHz, THD 1%)  
100 W + 100 W

Surround Mode Output Power<sup>2)</sup>  
(8 ohms, 1 kHz, THD 10%)  
130 W per channel

Canada, Europe, Australia and Taiwan models<sup>1)</sup>

Minimum RMS Output Power  
(8 ohms, 20 Hz – 20 kHz, THD 0.09%)  
85 W + 85 W

Stereo Mode Output Power  
(8 ohms, 1 kHz, THD 1%)  
100 W + 100 W

Surround Mode Output Power<sup>2)</sup>  
(8 ohms, 1 kHz, THD 10%)  
130 W per channel

<sup>1)</sup>Measured under the following conditions:

Area	Power requirements
USA, Canada, Taiwan	120 V AC, 60 Hz
Europe, Australia	230 V AC, 50 Hz

<sup>2)</sup>Reference power output for front, center, surround, surround back and front high speakers. Depending on the sound field settings and the source, there may be no sound output.

#### Frequency response

Analog 10 Hz – 70 kHz,  
+0.5/-2 dB (with sound field and equalizer bypassed)

#### Input

Analog (PORTABLE IN)  
Sensitivity: 1 V/50 kohms  
S/N<sup>3)</sup>: 96 dB (A, 500 mV<sup>4)</sup>)

Analog (Except PORTABLE IN)  
Sensitivity: 500 mV/  
50 kohms  
S/N<sup>3)</sup>: 96 dB (A, 500 mV<sup>4)</sup>)

Digital (Coaxial) Impedance: 75 ohms  
S/N: 100 dB  
(A, 20 kHz LPF)

Digital (Optical) S/N: 100 dB  
(A, 20 kHz LPF)

#### Output (Analog)

AUDIO OUT Voltage: 500 mV/1 kohm  
SUBWOOFER Voltage: 2 V/1 kohm

#### Equalizer

Gain levels ±10 dB, 1 dB step

<sup>3)</sup>INPUT SHORT (with sound field and equalizer bypassed).

<sup>4)</sup>Weighted network, input level.

#### FM tuner section

Tuning range 87.5 MHz – 108.0 MHz  
Antenna (aerial) FM wire antenna (aerial)  
Antenna (aerial) terminals 75 ohms, unbalanced  
Intermediate frequency 10.7 MHz

#### AM tuner section

Tuning range

Area	Tuning scale	
	10 kHz step	9 kHz step
USA, Canada	530 kHz – 1,710 kHz	531 kHz – 1,710 kHz
Europe, Australia, Taiwan	–	531 kHz – 1,602 kHz

Antenna (aerial) Loop antenna (aerial)

Intermediate frequency 450 kHz

## Video section

### Inputs/Outputs

Video: 1 Vp-p, 75 ohms

#### COMPONENT VIDEO:

Y: 1 Vp-p, 75 ohms

PB: 0.7 Vp-p, 75 ohms

PR: 0.7 Vp-p, 75 ohms

80 MHz HD Pass Through

## General

### Power requirements

Area	Power requirements
USA, Canada, Taiwan	120 V AC, 60 Hz
Europe, Australia	230 V AC, 50/60 Hz

Power consumption 240W

Power consumption (during standby mode)  
0.3 W (When  
“CTRL.HDMI” is set to  
“CTRL OFF”)

Dimensions (width/height/depth) (Approx.)  
430 mm × 157.5 mm ×  
322 mm (17 in × 6 1/4 in ×  
12 3/4 in) including  
projecting parts and  
controls

Mass (Approx.) 7.6 kg (16 lb 13 oz)

Design and specifications are subject to  
change without notice.

Halogenated flame retardants are not used in the certain printed wiring boards.
--

# Index

## Numerics

- 2 channel 43
- 5.1 channel 17
- 7.1 channel 17

## A

- A.F.D. mode 43
- Analog Direct 43
- AUTO CALIBRATION 31

## B

- Blu-ray Disc player
  - connecting 24

## C

- Cable TV tuner
  - connecting 26
- Clear
  - memory 29
  - remote control 62

## D

- Dolby Digital EX 46
- DVD player
  - connecting 24
- DVD recorder 27

## E

- Error messages 68

## H

- HD-D.C.S 44
- HDMI Signal Pass Through 60

## I

- Initial setup 29
- INPUT MODE 51

## M

- Menu
  - AUDIO 59
  - AUTO CAL 54
  - EQ 59
  - HDMI 60
  - LEVEL 57
  - SPEAKER 57
  - SURROUND 58
  - SYSTEM 60
  - TUNER 59
  - VIDEO 59
- Movie mode 43
- Music mode 44
- Muting 37

## N

- Naming 37, 42
- Night mode 13

## O

- One-Touch Play 49

## P

- PlayStation 3
  - connecting 25

## R

- RDS 42
- Recording 38
- Remote control 11

## S

- Satellite tuner
  - connecting 26
- Scene Select 50
- Sleep Timer 13
- Sound fields
  - resetting 47
  - selecting 43
- Speakers
  - connecting 19
  - installing 17
- System Audio Control 49
- System Power-Off 50

## T

- Test Tone 35
- Theater/Theatre Mode Sync 50
- Tuner
  - connecting 28
- Tuning
  - automatically 39
  - directly 40
  - to preset stations 41
- TV
  - connecting 21

## V

- VCR
  - connecting 27



\* 4 2 6 3 3 6 1 1 1 \* (2)