



MPK mini

User Guide

English (3 – 5)

Guía del usuario

Español (6 – 8)

Guide d'utilisation

Français (9 – 11)

Guida per l'uso

Italiano (12 – 14)

Benutzerhandbuch

Deutsch (15 – 17)

Appendix

English (18)

User Guide (English)

Introduction

Box Contents

MPK mini
USB Cable
MPK mini Editor (*download*)
Software Download Card
User Guide
Safety & Warranty Manual

Support

For the latest information about this product (system requirements, compatibility information, etc.) and product registration, visit akaipro.com/mpkmini.

For additional product support, visit akaipro.com/support.

Quick Start

Device Setup in Software

To select MPK mini as a controller for your digital audio workstation (DAW):

1. Connect MPK mini to your computer using a standard USB cable. (If you are connecting MPK mini to a USB hub, make sure it is a powered hub.)
2. Open your DAW.
3. Open your DAW's **Preferences**, **Options**, or **Device Setup**, select **MPK mini** as your hardware controller, and then close that window.

Your MPK mini is now able to communicate with your software.

MPK mini Editor Installation

We recommend visiting akaipro.com/mpkmini and downloading the **MPK mini Editor**, which gives you a visual and intuitive way to edit the various MIDI messages that MPK mini's controls (pads, knobs, and X-Y controller) send to your computer.

Learn more about the MPK mini Editor in the *User Guide* included with the download package.

Features

Top Panel

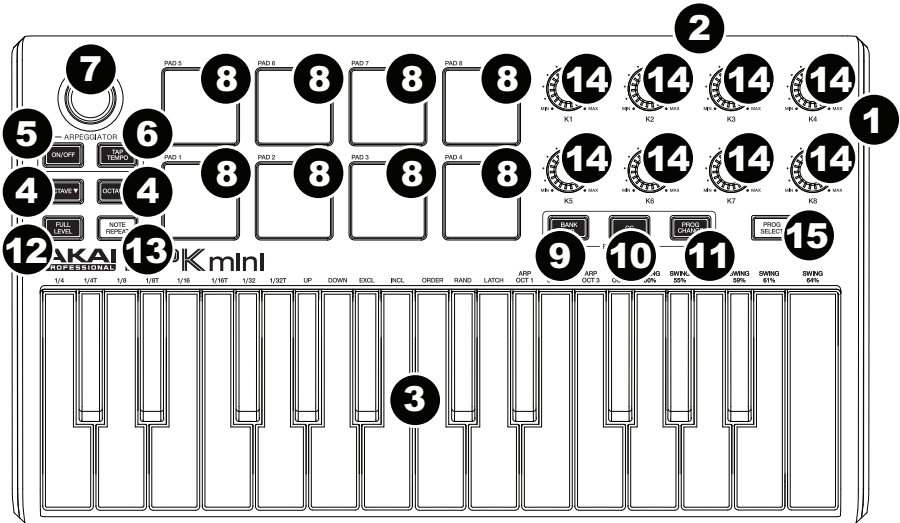

- 1. USB Port:** Use a standard USB cable to connect this USB port to a USB port on your computer. The computer's USB port will provide power to MPK mini. This connection is also used to send and receive MIDI data to and from your computer.
- 2. Sustain Pedal Input:** Connect an optional 1/4" TS sustain pedal to this input.
- 3. Keyboard:** This 25-note keyboard is velocity-sensitive and, in conjunction with the **Octave Down / Up** buttons, can control a ten-octave range. You can use the keys to access certain additional commands, as well.
- 4. Octave Down / Up:** Use these buttons to shift the keyboard's range up or down (up to four octaves in either direction). When you are higher or lower than the center octave, the corresponding Octave button will light. Press both Octave buttons simultaneously to reset the keyboard to the default center octave.
- 5. Arpeggiator On/Off:** Press this button to turn the Arpeggiator on or off. Pressing it during a latched arpeggio will stop the arpeggio.

Hold down **Arpeggiator On/Off** and press a key on MPK mini's keyboard to enter new settings for the Arpeggiator:

- **Time Division:** 1/4 note, 1/4 note triplet (1/4T), 1/8 note, 1/8 note triplet (1/8T), 1/16 note, 1/16 note triplet (1/16T), 1/32 note, or 1/32 note triplet (1/32T).
- **Mode:** The mode determines how the arpeggiated notes are played back.
 - **Up:** Notes will sound from the lowest to the highest.
 - **Down:** Notes will sound from the highest to lowest.
 - **Incl (Inclusive):** Notes will sound from the lowest to the highest, and then back down. The lowest and highest notes will sound *twice* at the directional change.
 - **Excl (Exclusive):** Notes will sound from the lowest to the highest, and then back down. The lowest and highest notes will sound *only once* at the directional change.
 - **Order:** Notes will sound in the order they were pressed.

- **Rand** (Random): Notes will sound in random order.
 - **Latch**: The Arpeggiator will continue to arpeggiate the notes even after you lift your fingers. While holding down the keys, you can add more notes to the arpeggiated chord by pressing down additional keys. If you press the keys, release them, and then press down a new combination of notes, the Arpeggiator will memorize and arpeggiate the new notes.
 - **Octave**: Arpeggio octave range (**Arp Oct**) of **0, 1, 2, or 3** octaves.
 - **Swing**: **50%** (no swing), **55%**, **57%**, **59%**, **61%**, or **64%**.
6. **Tap Tempo**: Tap this button at the desired rate to determine the tempo of the Arpeggiator. The minimum number of taps required is programmable in the MPK mini Editor.
- Note**: This button is disabled if the Arpeggiator is synced to an external clock.
7. **X-Y Controller**: Use this 4-axis thumbstick to send MIDI pitch bend messages or send MIDI CC messages. You can use the free, downloadable MPK mini Editor to assign how this X-Y Controller functions.
8. **Pads**: The pads can be used to trigger drum hits or other samples in your software. The pads are velocity-sensitive, which makes them very responsive and intuitive to play. You can use the free, downloadable MPK mini Editor to assign what MIDI message each pad (in each pad bank) sends.
9. **Bank A/B**: Press this button to switch MPK mini's pads between Pad Bank A or Pad Bank B. You can use the free, downloadable MPK mini Editor to assign what MIDI message each pad (in each pad bank) sends.
10. **CC**: When this button is active, MPK mini's pads will send MIDI CC messages instead of MIDI Note On messages. You can use the free, downloadable MPK mini Editor to assign what CC message each pad sends.
11. **Prog Change**: When this button is active, MPK mini's pads will send MIDI Program Change messages instead of MIDI Note On messages. You can use the free, downloadable MPK mini Editor to assign what Program Change message each pad sends.
12. **Full Level**: Press this button to activate or deactivate Full Level Mode in which the pads always play at a maximum velocity (127), no matter how hard or soft you hit them.
13. **Note Repeat**: Press and hold this button while striking a pad to cause the pad to retrigger at a rate based on the current Tempo and Time Division settings.
14. **Assignable Knobs**: Each 270° knob sends a MIDI CC message. You can use the free, downloadable MPK mini Editor to assign what CC message each knob sends.
15. **Prog Select**: Hold down this button and press **Pad 5**, **Pad 6**, **Pad 7**, or **Pad 8** to select the Program whose number is printed above that pad (**Prog 1**, **Prog 2**, **Prog 3**, or **Prog 4**).