

# Quick Start Guide

## 快速启动指南

中文P11

**WARNING**  
注意事项

1. Do not remove the wrapping around the nozzle.
  2. Hot! Avoid touching the heating nozzle in operation.
  3. Moving parts in printer may cause injury. Do not wear gloves or other sources of entanglement in operation.
1. 切勿去除包裹在喷嘴处的耐高温材料。
  2. 高温危险！打印机喷嘴在工作时会被加热，操作时请避免接触！
  3. 可动部件可能会造成卷入挤压和切割伤害。操作机器时请不要配带手套或缠绕物。



# Unpacking



1. Open the box.



2. Remove wrapping paper box on the top, there is a Quick start, an after-sales service, an accessory kit, a power cable and a roll of material on the plastic box.



3. Take out the printer of the carton, remove bubble pack outside the printer.



4. Tear off fixed tapes and front door protective bag.



5. Take power cable out and plug it into power input.

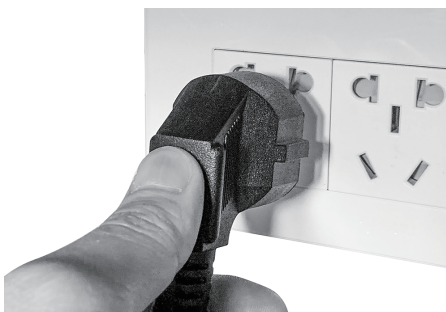

6. Plug the other end of power cable into socket, turn on the power switch.



7. Turn on the power switch.



8. Open the front door.

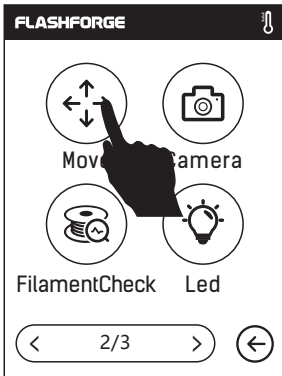
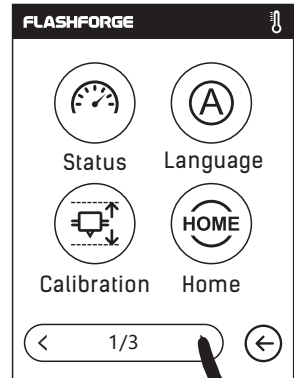
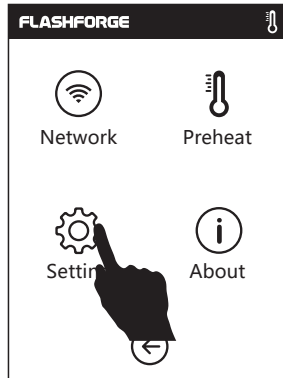
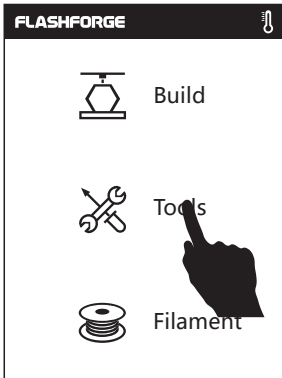

9. Tap [Tools]-[Setting] on the touch screen as the picture showed above, tap [Move].

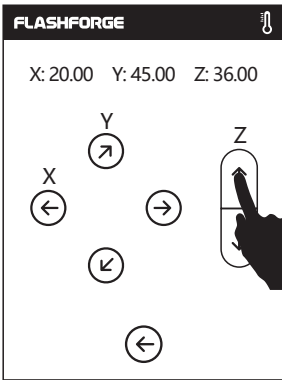

10. Tap the upper arrow in the moving page to make the extruder raises for removing the paper box on the bottom easier.



11. Squeeze wrapping paper box to the middle slightly and take it out.



12. Unboxing completed! Recommended that you take good care of packing materials for further carrying and keeping.

## Kit Contents

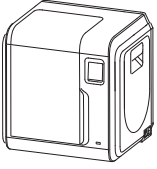

3D Printer



Filament



Power Cable



After-sales  
service card



Quick Start Guide



Screwdriver

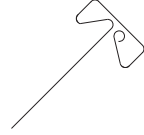

Unclogging Pin Tool



Allen Wrench

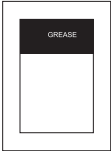

Grease

## Getting to know your Adventurer 3

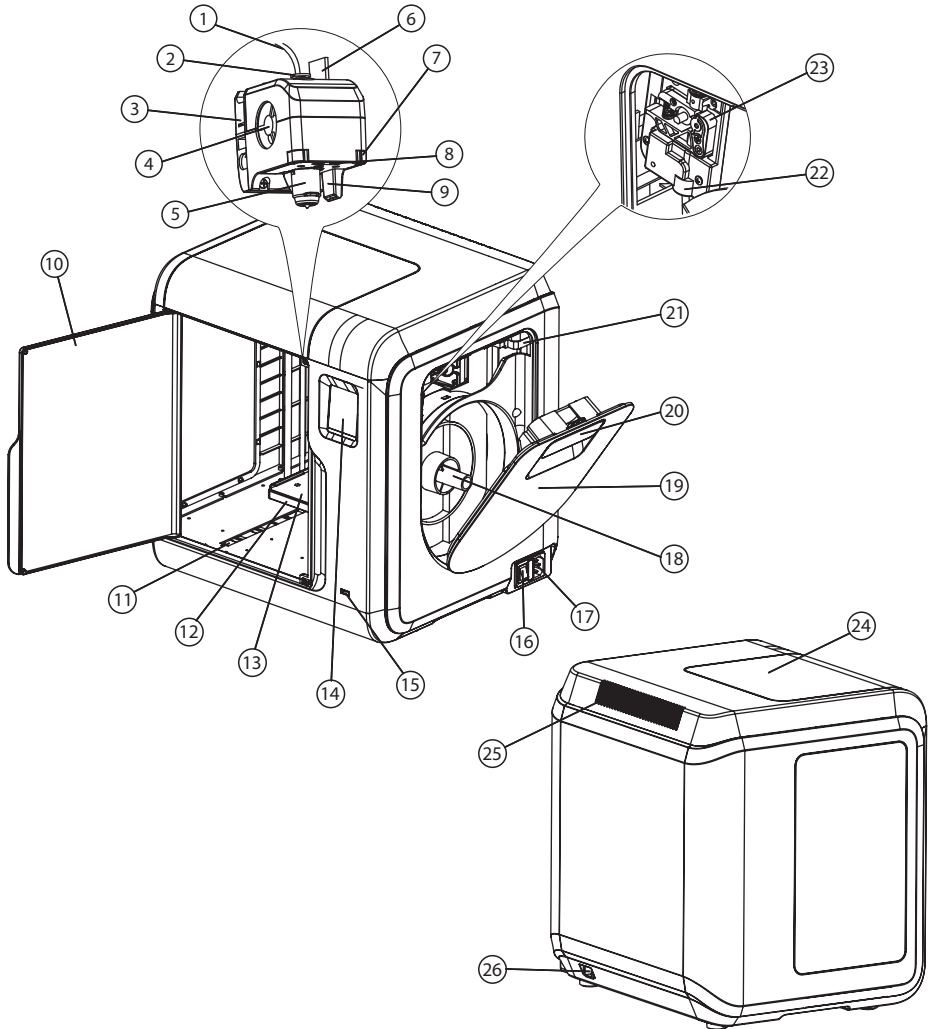

1. Filament guide tube    2. Filament guide tube joint    3. Extruder base    4. Cooling Fan  
 5. Removable nozzle    6. Extruder cables    7. Clip    8. Led light  
 9. Turbo Fan Baffle    10. Front door    11. Y-Axis sliding slot    12. Platform base  
 13. Removable build plate    14. Touch-screen    15. USB stick input    16. Power switch  
 17. Power input    18. Spool holder    19. Filament cover    20. Filament cover handle  
 21. Moto    22. Filament intake    23. Filament feeding wheel    24. Top cover  
 25. Air outlet    26. Ethernet input

# First Print

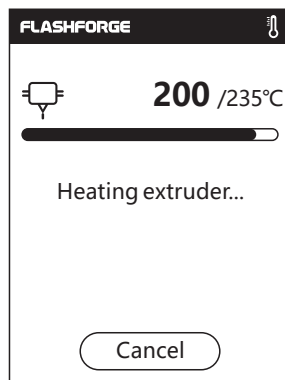
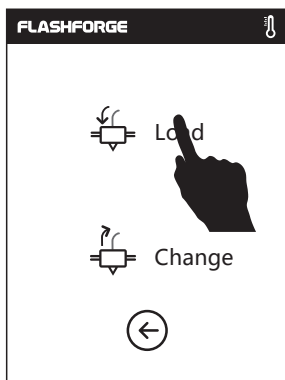
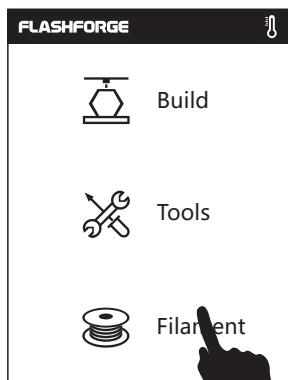

1. Tap [Filament], tap [Load], after load completed, tap [OK].

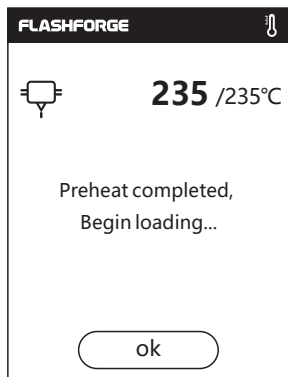

2. As shown on the left, loading starts when the extruder heated to target temperature.

3. Open the filament cover, insert the filament into the filament intake, push filament into the feeding wheel until some resistance is sensed.

**Note: Please make sure filament has been pushed into the feeding wheel!**

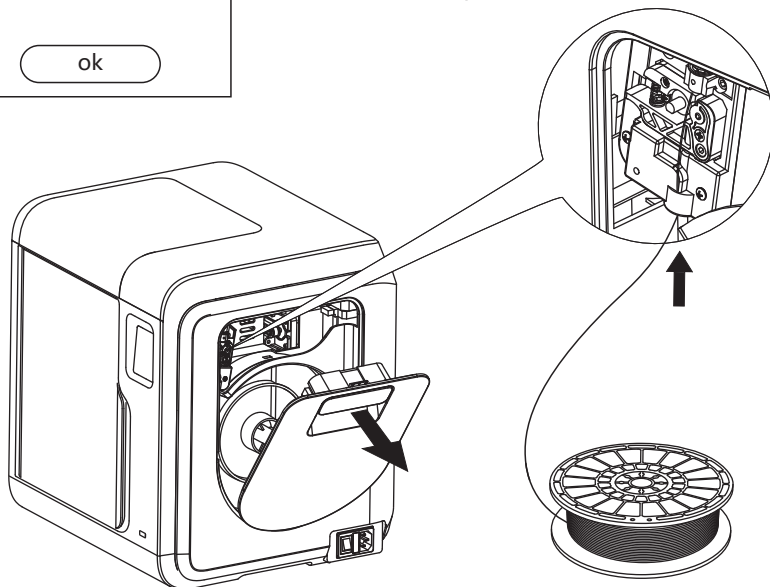

Mind the loading direction of filament, make sure to be clockwise as the picture showed.

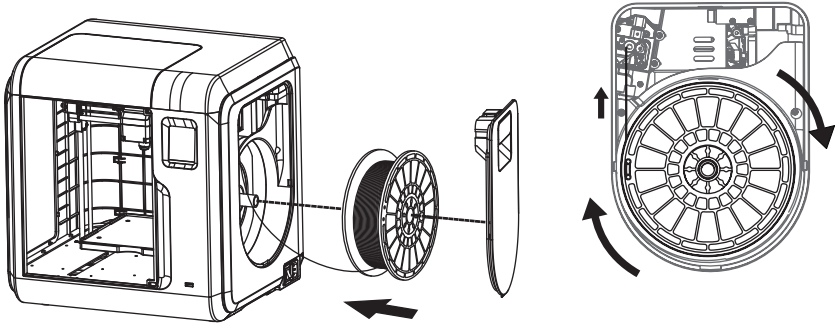



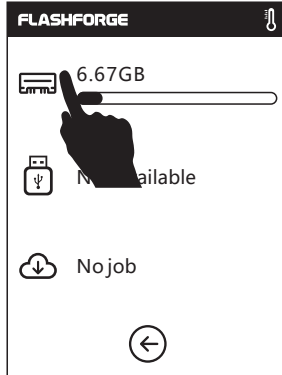
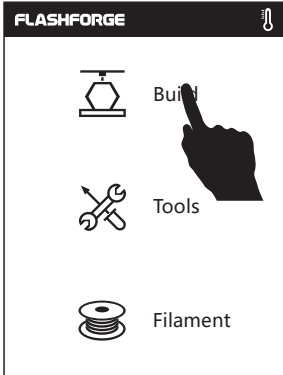

4. Load completed when you see filament come out of extruder, tap [OK]. Put the spool of filament on the spool holder, close the filament cover.

## Model Print

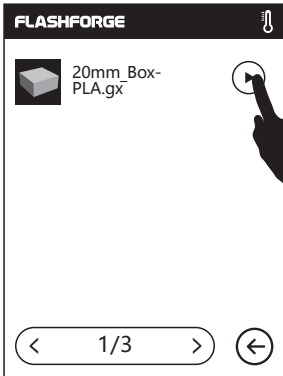

1. Tap [Build], choose the file path: Print from local memory card. 



2. Locate the model file  in the model list, Tap  on its right to start printing; or tap model file picture or file name to enter model details page, tap  to start printing.

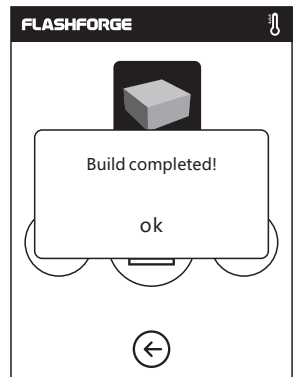
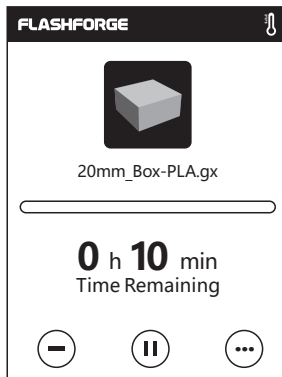
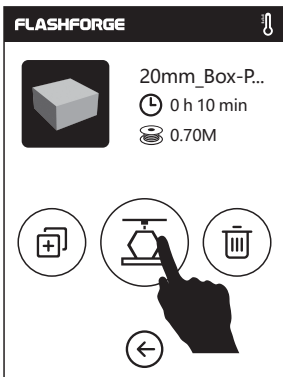

3. Extruder will heat up and printer will start printing after heating completed. After model printing finished, printer will sound a beep and pop out notice on touch screen.

## Model Remove

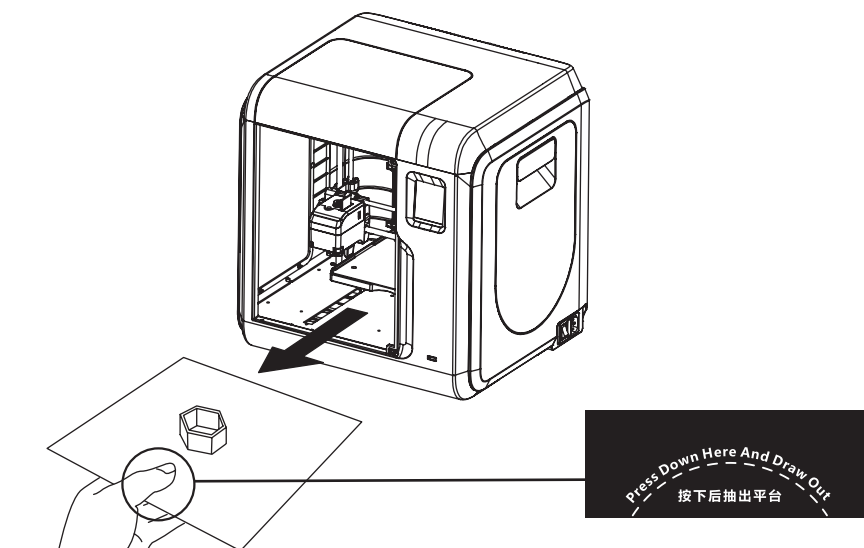

1. As showed in picture, press down dotted line area and draw out the removable build plate.

### ⚠ Notices

When printing completed, extruder and build plate may still hot, please start operating after cooling down!

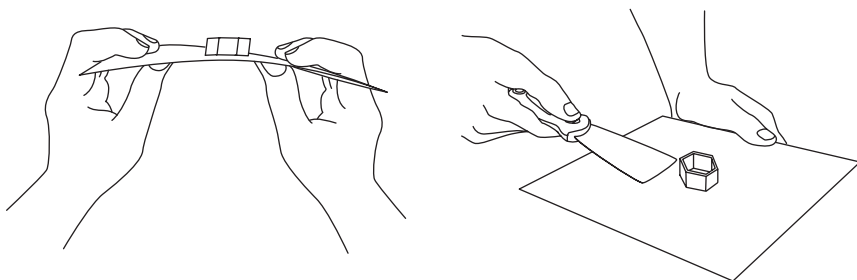

2. Bend the build plate, the plate will produce certain deformation, seperating the plate away from the bottom of model (Please use a scraper to assist removing when model is too small or big).

# Change Filament

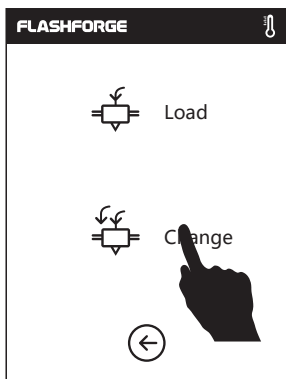

1. Tap [Filament], tap [Change], extruder starts preheating.

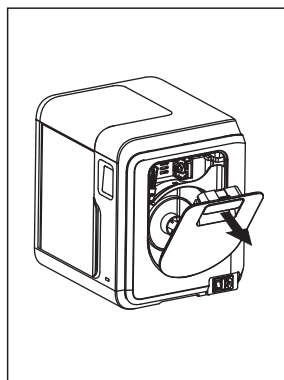
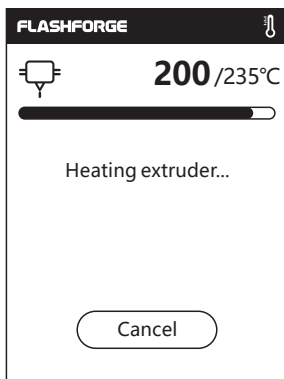

2. Open the filament cover.

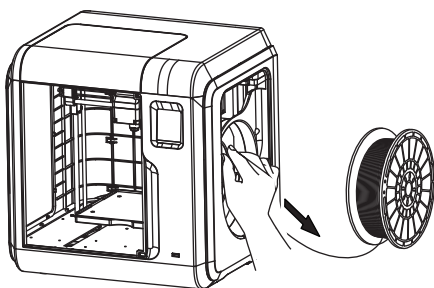

3. Pull out the filament as the picture showed above.

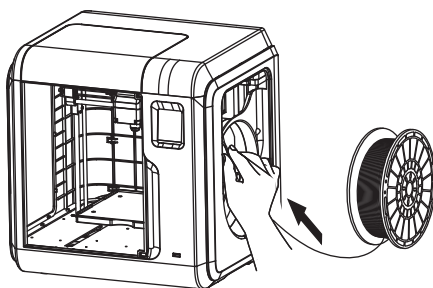

4. Insert new filament into the filament intake and push the filament into the feeding wheel until resistance is sensed.

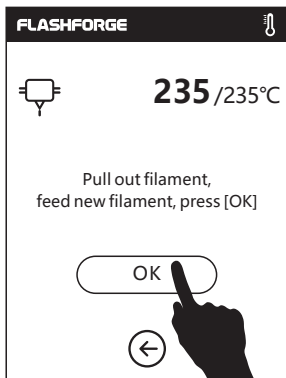

5. Tap [ok] after plugging in new filament, loading starts. When new filament come out of extruder steadily, replace is completed, tap [OK].

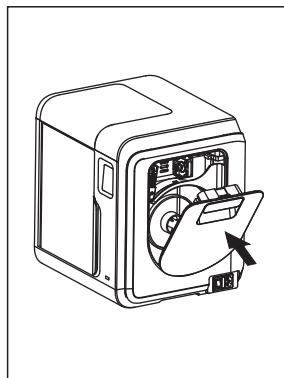

6. Put the spool of filament on the spool holder, close the filament cover.