

- USER MANUAL
- MANUEL DE L'UTILISATEUR
- BENUTZERHANDBUCH
- HANDLEIDING
- MANUALE D'USO
- MANUAL DEL USUARIO
- MANUAL DO UTILIZADOR
- РУКОВОДСТВО ПОЛЬЗОВАТЕЛЯ
- ΕΓΧΕΙΡΙΔΙΟ ΧΡΗΣΗΣ
- KULLANMA KILAVUZU
- INSTRUKCJA OBSŁUGI

- ユーザーマニュアル
- 用户手册

- دليل المستخدم

THRUSTMASTER®

T.16000M

Most Accurate Ever : 16000 x 16000 dots stick resolution

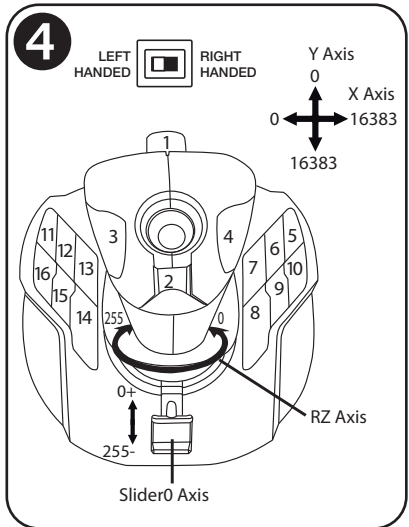
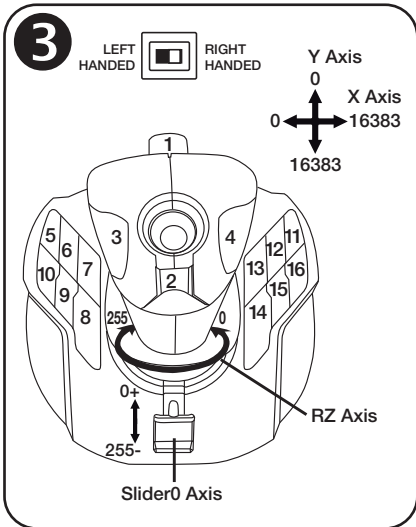
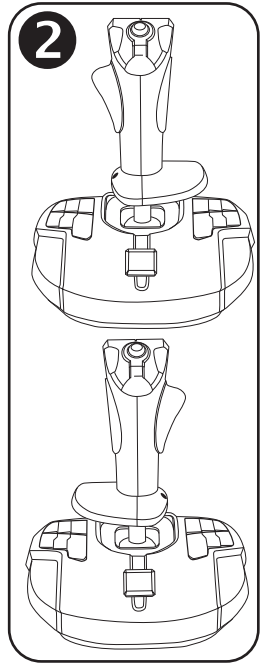
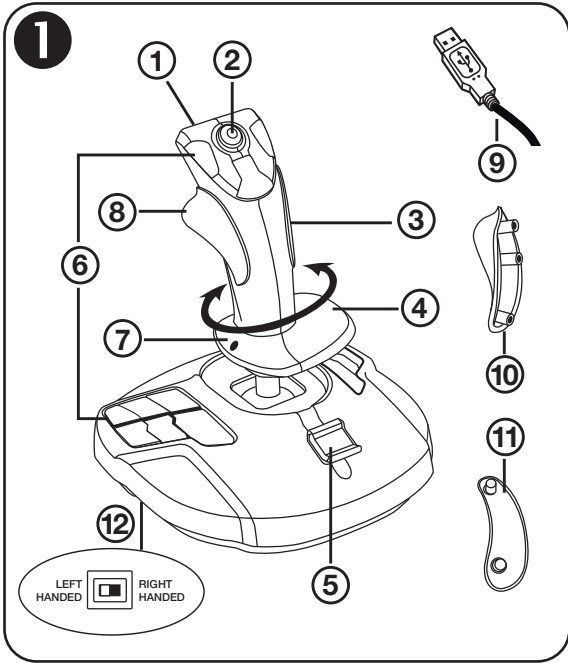

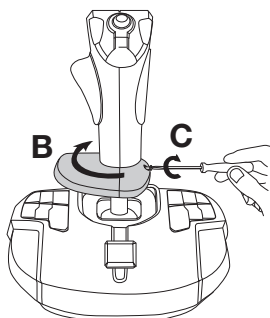
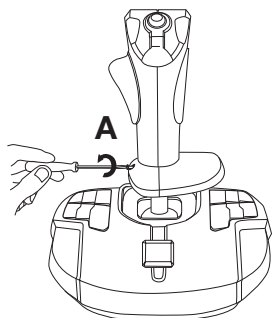
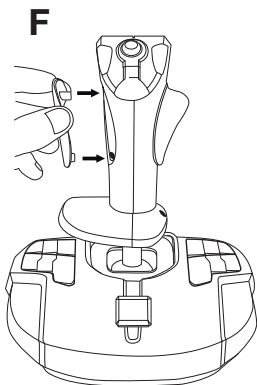
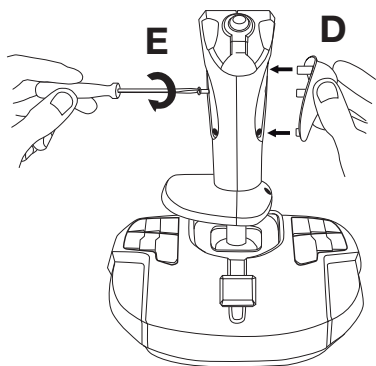
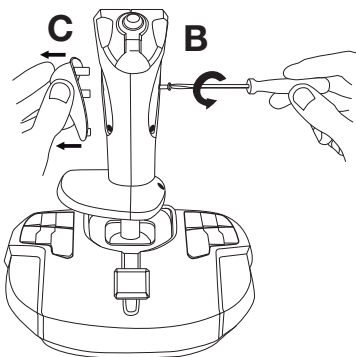
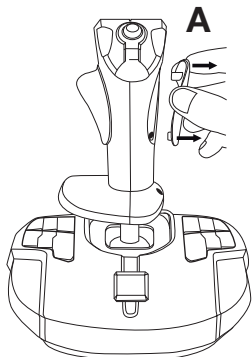
5**6**



Compatible: PC User Manual

TECHNICAL FEATURES **I**

1. Digital trigger
2. Multidirectional "Point of View" hat switch
3. Right-handed screw cover
4. Rudder control via rotating handle with hand rest
5. Throttle
6. 15 action buttons
7. Hand rest rotation screw, with right-handed or left-handed positions
8. Right-handed thumb rest
9. PC USB connector
10. Left-handed thumb rest
11. Left-handed screw cover
12. Right-handed or left-handed buttons selector switch

GETTING TO KNOW YOUR JOYSTICK

EXCLUSIVE PRECISION TECHNOLOGY:

"H.E.A.R.T™: HallEffect AccuRate Technology"

Your T-16000M joystick features technology providing it with a level of precision currently unequalled in the world of gaming joysticks, including:

- A 3D (Hall Effect) magnetic sensor on the stick, with a resolution of more than 268 million values over the X and Y axes (16384 x 16384 values), whereas current competing systems (even high-end systems) provide resolutions in the neighborhood of only one million values (1024 x 1024 values).
- A magnet: no friction, for unlimited precision and incredible responsiveness.
- Coil spring on stick (2.8mm): for firm, linear and ultra-fluid tension.

BACKLIGHTING

For even greater precision, there is no dead zone in the central position of the T-16000M's stick. To symbolize this, the center is backlit in green as soon as you move the stick (even very slightly); the backlighting switches off after 3 seconds of inactivity, once you have brought the stick back to dead center.

THROTTLE

Your joystick features a throttle **(5)**, which you can use to easily control your acceleration in games.

RUDDER FUNCTION

Your joystick features a rudder function (4), which in an airplane corresponds to the pedals used by the pilot to move the rudder, thereby allowing the plane to pivot around its vertical axis (making the plane turn to the left or to the right).

This rudder function is available on your joystick by rotating the stick to the left or right.

MULTIDIRECTIONAL "POINT OF VIEW" HAT SWITCH

Your joystick features a "Point of View" hat switch (2) which, as its name indicates, allows you to instantly view everything that is going on around your aircraft (in games where this feature is enabled). To use this feature, simply go into your game's setup menu, and program the different views (rear view, view to the left, view to the right, and also external views) onto the directions of the "Point of View" hat switch.

If you wish, you can also reserve the "Point of View" hat switch for other uses instead (firing, etc.).

AMBIDEXTROUS SYSTEM ②

Your T-16000M joystick has the advantage of being fully ambidextrous, allowing it to perfectly adapt to all players, whether they are right-handed or left-handed.

To do so, 3 elements can be adjusted: the configuration of the buttons on the base, the hand rest, and the thumb rest.

CONFIGURATION OF BUTTONS IN RIGHT-HANDED MODE ③

To set the positions of the 12 buttons located on the base to right-handed mode, set the selector switch (12) located under the joystick's base to "RIGHT HANDED":

CONFIGURATION OF BUTTONS IN LEFT-HANDED MODE ④

To set the positions of the 12 buttons located on the base to left-handed mode, set the selector switch (12) located under the joystick's base to "LEFT HANDED":

ADJUSTING THE HAND REST FOR RIGHT- OR LEFT-HANDED MODE ⑤

By default, the hand rest is configured in RIGHT-HANDED MODE.

To adjust it to LEFT-HANDED MODE:

- A) Using a small screwdriver, carefully loosen (without actually removing) the small hand rest rotation screw (7), located on the left of the hand rest.
- B) Turn the hand rest 180°.
- C) Completely tighten the screw on the hand rest again (now located on the right).

Note: Carry out this procedure in reverse to return to right-handed mode.

ADJUSTING THE THUMB REST FOR RIGHT- OR LEFT-HANDED MODE 6

By default, the stick's thumb rest is configured in RIGHT-HANDED MODE.
To adjust it to LEFT-HANDED MODE:

- A) Remove the right-handed screw cover (3) located on the right of the stick.
- B) Using a small screwdriver, unscrew and completely remove the long screw now accessible (on the right of the stick).
- C) Remove the right-handed thumb rest (8) located on the left of the stick.
- D) Position the left-handed thumb rest (10) (included separately in the joystick's box) on the right of the stick.
- E) Position the long screw in the opening on the left of the stick and completely tighten the screw in order to fasten the left-handed thumb rest in place.
- F) Position the left-handed screw cover (11) (included separately in the joystick's box) on the left of the stick.

Note: Carry out this procedure in reverse to return to right-handed mode.

PC

INSTALLATION ON PC

1. Connect the PC USB connector (9) to one of your computer's USB ports.
Windows XP, Vista, 7 or 8 will automatically detect the new device.
2. The drivers are installed automatically.
Follow the on-screen instructions to complete the installation.
3. Click **Start/Settings/Control Panel** and double-click **Game Controllers**.
*The **Game Controllers** dialog box displays the joystick's name with **OK** status.*
4. In the **Control Panel**, click **Properties** to test and view all of your joystick's functions.

You are now ready to play!

IMPORTANT NOTE

When connecting your joystick: always set the stick and the rudder to their central positions, and avoid moving them (to avoid any calibration problems).

TROUBLESHOOTING AND WARNING

- **My joystick isn't functioning properly or seems to be improperly calibrated:**

- Power off your computer and disconnect your joystick; then, turn your computer back on, reconnect your joystick and restart your game.
- When connecting your joystick: always set the stick and the rudder to their central positions, and avoid moving them (to avoid any calibration problems).

- **I can't configure my joystick:**

- In your game's "Options/Controller/Gamepad or Joystick" menu: select the appropriate configuration, or completely reconfigure the controller options.

- Please refer to your game's user manual or online help utility for more information.

- **My joystick is too sensitive or not sensitive enough:**

- Your joystick self-calibrates independently once you have made some movements along the different axes.

- In your game's "Options/Controller/Gamepad or Joystick" menu: adjust the sensitivity and dead zones for your joystick (if these options are available).

- **The joystick's central backlighting doesn't turn off automatically:**

- Move the stick very slightly so that it is set to the absolute central value; the backlighting will then switch off after 3 seconds of inactivity.

CONSUMER WARRANTY INFORMATION

Worldwide, Guillemot Corporation S.A., whose registered office is located at Place du Granier, B.P. 97143, 35571 Chantepie, France (hereinafter "Guillemot") warrants to the consumer that this Thrustmaster product shall be free from defects in materials and workmanship, for a warranty period which corresponds to the time limit to bring an action for conformity with respect to this product. In the countries of the European Union, this corresponds to a period of two (2) years from delivery of the Thrustmaster product. In other countries, the warranty period corresponds to the time limit to bring an action for conformity with respect to the Thrustmaster product according to applicable laws of the country in which the consumer was domiciled on the date of purchase of the Thrustmaster product (if no such action exists in the corresponding country, then the warranty period shall be one (1) year from the original date of purchase of the Thrustmaster product).

Notwithstanding the above, rechargeable batteries are covered by a warranty period of six (6) months from the date of original purchase.

Should the product appear to be defective during the warranty period, immediately contact Technical Support, who will indicate the procedure to follow. If the defect is confirmed, the product must be returned to its place of purchase (or any other location indicated by Technical Support).

Within the context of this warranty, the consumer's defective product shall, at Technical Support's option, be either replaced or returned to working order. If, during the warranty period, the Thrustmaster product is subject to such reconditioning, any period of at least seven (7) days during which the product is out of use shall be added to the remaining warranty period (this period runs from the date of the consumer's request for intervention or from the date on which the product in question is made available for reconditioning, if the date on which the product is made available for reconditioning is subsequent to the date of the request for intervention). If permitted under applicable law, the full liability of Guillemot and its subsidiaries (including for consequential damages) is limited to the return to working order or the replacement of the Thrustmaster product. If permitted under applicable law, Guillemot disclaims all warranties of merchantability or fitness for a particular purpose.

This warranty shall not apply: (1) if the product has been modified, opened, altered, or has suffered damage as a result of inappropriate or abusive use, negligence, an accident, normal wear, or any other cause unrelated to a material or manufacturing defect (including, but not limited to, combining the Thrustmaster product with any unsuitable element, including in particular power supplies, rechargeable batteries, chargers, or any other elements not supplied by Guillemot for this product); (2) if the product has been used for any use other than home use, including for professional or commercial purposes (game rooms, training, competitions, for example); (3) in the event of failure to comply with the instructions provided by Technical Support; (4) to software, said software being subject to a specific warranty; (5) to consumables (elements to be replaced over the product's lifespan: disposable batteries, audio headset or headphone ear pads, for example); (6) to accessories (cables, cases, pouches, bags, wrist-straps, for example); (7) if the product was sold at public auction.

This warranty is nontransferable.

The consumer's legal rights with respect to laws applicable to the sale of consumer goods in his or her country are not affected by this warranty.

Additional warranty provisions

During the warranty period, Guillemot shall not provide, in principle, any spare parts, as Technical Support is the only party authorized to open and/or recondition any Thrustmaster product (with the exception of any reconditioning procedures which Technical Support may request that the consumer carry out, by way of written instructions – for example, due to the simplicity and the lack of confidentiality of the reconditioning process – and by providing the consumer with the required spare part(s), where applicable).

Given its innovation cycles and in order to protect its know-how and trade secrets, Guillemot shall not provide, in principle, any reconditioning notification or spare parts for any Thrustmaster product whose warranty period has expired.

In the United States of America and in Canada, this warranty is limited to the product's internal mechanism and external housing. In no event shall Guillemot or its affiliates be held liable to any third party for any consequential or incidental damages resulting from the breach of any express or implied warranties. Some States/Provinces do not allow limitation on how long an implied warranty lasts or exclusion or limitation of liability for consequential or incidental damages, so the above limitations or exclusions may not apply to you. This warranty gives you specific legal rights, and you may also have other rights which vary from State to State or Province to Province.

Liability

If permitted under applicable law, Guillemot Corporation S.A. (hereinafter "Guillemot") and its subsidiaries disclaim all liability for any damages caused by one or more of the following: (1) the product has been modified, opened or altered; (2) failure to comply with assembly instructions; (3) inappropriate or abusive use, negligence, an accident (an impact, for example); (4) normal wear; (5) the use of the product for any use other than home use, including for professional or commercial purposes (game rooms, training, competitions, for example). If permitted under applicable law, Guillemot and its subsidiaries disclaim all liability for any damages unrelated to a material or manufacturing defect with respect to the product (including, but not limited to, any damages caused directly or indirectly by any software, or by combining the Thrustmaster product with any unsuitable element, including in particular power supplies, rechargeable batteries, chargers, or any other elements not supplied by Guillemot for this product).

FCC STATEMENT

1. This device complies with Part 15 of the FCC Rules. Operation is subject to the following two conditions:

(1) This device may not cause harmful interference, and
(2) This device must accept any interference received, including interference that may cause undesired operation.

2. Changes or modifications not expressly approved by the party responsible for compliance could void the user's authority to operate the equipment.

COPYRIGHT

© 2017 Guillemot Corporation S.A. All rights reserved. Thrustmaster® is a registered trademark of Guillemot Corporation S.A. Windows® is a registered trademark of Microsoft Corporation in the United States and/or other countries. All other trademarks are the property of their respective owners. Illustrations not binding. Contents, designs and specifications are subject to change without notice and may vary from one country to another. Made in China.

ENVIRONMENTAL PROTECTION RECOMMENDATION



* In the European Union: At the end of its working life, this product should not be disposed of with standard household waste, but rather dropped off at a collection point for the disposal of Waste Electrical and Electronic Equipment (WEEE) for recycling.

This is confirmed by the symbol found on the product, user manual or packaging.

Depending on their characteristics, the materials may be recycled. Through recycling and other forms of processing Waste Electrical and Electronic Equipment, you can make a significant contribution towards helping to protect the environment.

Please contact your local authorities for information on the collection point nearest you.

For all other countries: Please adhere to local recycling laws for electrical and electronic equipment.

Retain this information. Colours and decorations may vary.

Plastic fasteners and adhesives should be removed from the product before it is used.

www.thrustmaster.com

**Applicable to EU and Turkey only*



THRUSTMASTER®

TECHNICAL SUPPORT

<http://support.thrustmaster.com>

