

MKH 50 P 48

Bedienungsanleitung
Instructions for use
Notice d'emploi
Istruzioni per l'uso
Instrucciones para el uso

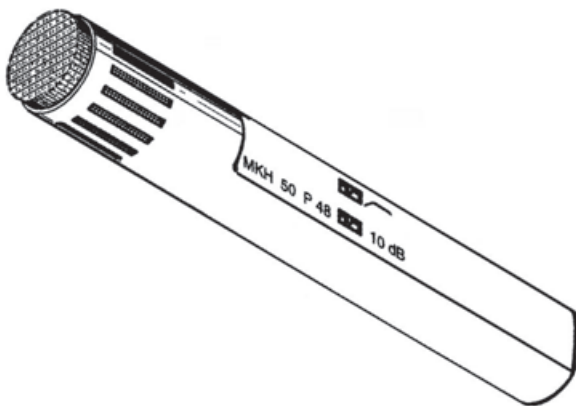

Brief description

The MKH 50 P 48 is a high-frequency condenser microphone with supercardioid characteristics. Its features include:

- Very low noise level, making possible high-dynamic recordings
- Supercardioid directional characteristic through virtually the entire frequency spectrum
- Wide frequency response range
- Electronically balanced output
- Pad switch (-10 dB attenuation)
- Defeatable roll-off filter

Putting into service

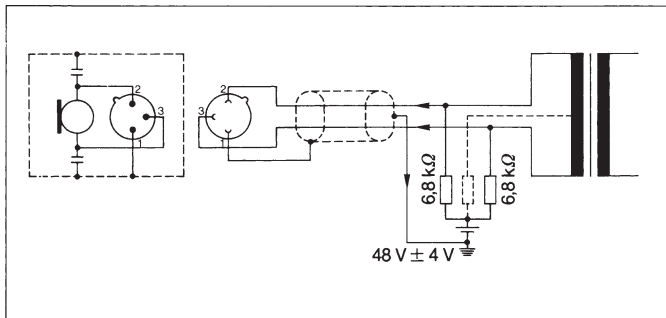

Power supply and connections

The MKH 50 P 48 is designed for use with a phantom power supply between 44 and 52 V, as prescribed in DIN 45 596.

Plug:	3-pole XLR
Wiring:	balanced
Impedance:	150 Ω
Min. terminating impedance:	1000 Ω

See page 18 for powering and connection possibilities.

Note: Extension cables should if possible be inserted between the power supply unit and the audio recorder or mixer. Total cable length should not exceed 200 m. At greater lengths the cable capacitance will affect microphone frequency response at the upper end of the response range.

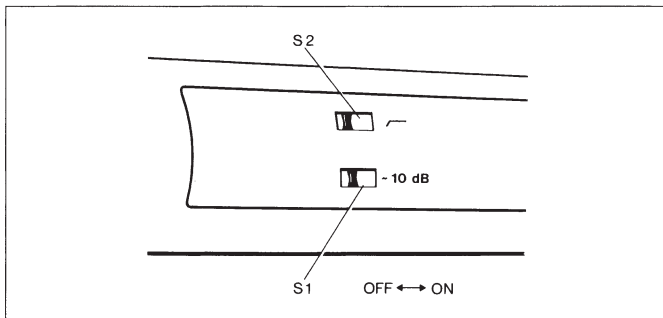

Setting the pre-attenuation and roll-off filter

Pre-attenuation **S 1**

Pad switch **S 1** is used to attenuate microphone sensitivity by 10 dB. This feature should be used only when the microphone input at downline equipment is not designed to handle the high microphone output voltages generated at high sound pressure levels (which would result in distortion).

Setting the roll-off filter **S 2**

The MKH 50 P 48 is equipped with a switchable roll-off filter to compensate for the proximity effect which is common for microphones and to avoid low-frequency interference due to footfall vibration. The filter design is such that the proximity effect is compensated for at distances from 40 to 60 cm. The effect of the roll-off filter on the frequency response is shown on page 16. Regardless of the setting of switch **S 2**, a cut-off filter is effective below 30 Hz to suppress disturbances due to low-frequency air or body noises (subsonic signals).

Mounting the microphone

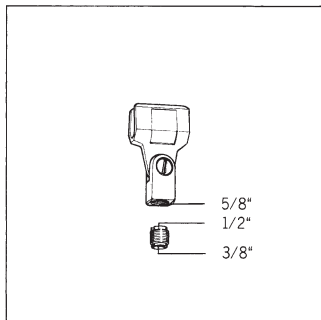
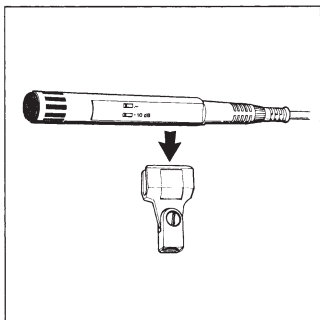

The stand socket is equipped with a threaded, interchangeable insert to adapt to stands with 3/8", 1/2" or 5/8" threads.

Technical data

Acoustic principle	pressure-gradient receiver
Directional characteristic	supercardioid
Frequency response range	40 to 20.000 Hz
Free-field, no-load transmission factor at 1 kHz	25 mV/Pa (8 mV/Pa) \pm -32 dBV (-42 dBV)
Equivalent sound pressure level	
as per DIN 45 500, curve A	12 dB (18 dB)
as per DIN 45 405/CCIR 468	21 dB (27 dB)
Max. sound pressure level	134 dB (142 dB)
Output	balanced
Nominal impedance	150 Ω
Min. terminating impedance	1000 Ω
Pre-attenuation	10 dB, defeatable
Low-cut filter	12 dB/oct below 30 Hz
Roll-off filter (switch setting " Γ ")	additional 4 dB attenuation at 50 Hz
Power supply	Phantom supply as per DIN 45 596
Supply voltage	44 to 52 V
Supply current	2 mA
Dimensions (mm)	25 \varnothing x 150
Weight	110 g
Standard equipment	1 MKH 50 P 48 microphone 1 MZQ 40 stand adapter 1 MZW 41 windscreen

Values in brackets with pad switch in position -10 dB

We reserve the right to adopt changes, particularly in the interest of technical progress.

dB Frequency response

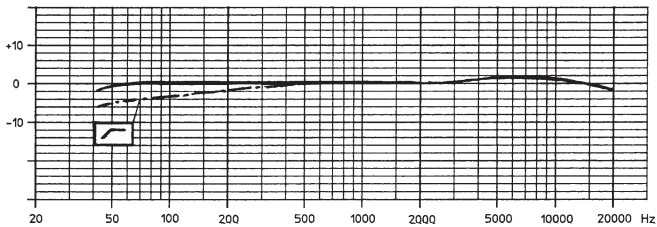

dB Effect of the roll-off filter

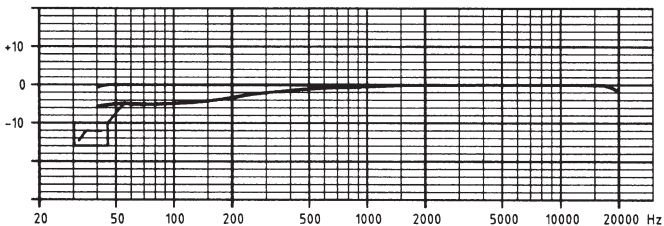

Polar diagram

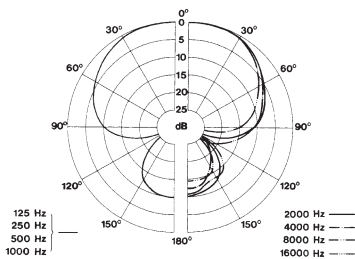

Recommended accessories

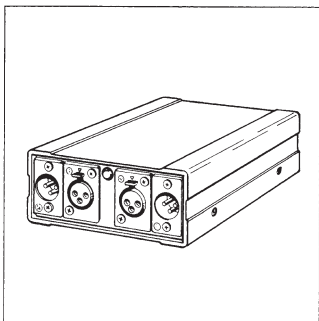

MZN 16 P 48 U power supply

(Art.No. 1241)

Power supply for 48 V phantom supply (DIN 45 596). Allows simultaneous supply of two microphones. Required line voltage: 95 to 265 V/50–60 Hz.

KA 7 U connector cable

(Art.No. 1777)

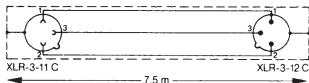

Three-conductor, shielded cable; 7.5 m long.

Suspension MZS 40

(Art.No. 03017)

Features high damping of structure-borne noise.

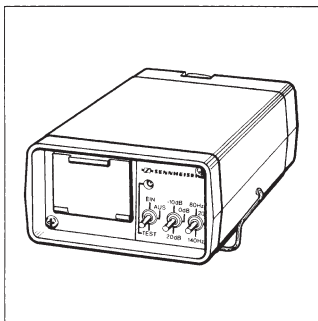

Battery-powered supply adapter

MZA 14 P 48 U

(Art.No. 2034)

Adapter to supply one microphone, independent of a line power source converter which boosts the voltage. The MZA 14 48 U contains a voltage of a 9 V battery to 48 V. Battery life: approx. 25 hours. Output suitable for connection to balanced and unbalanced microphone inputs. Special features: defeatable 10 dB preattenuation; switchable low-cut filter. Dimensions: 140 x 46 x 76 mm.

Stand holder MZQ 31

(Part. No. 35972)

Enables microphone adjustment in any direction.

Twin clip MZD 30

(Art.No. 02990)

For mechanical connection when used for MS-stereo recordings (Blumlein configuration).

Powering and connection possibilities

Connecting to balanced, groundfree microphone inputs

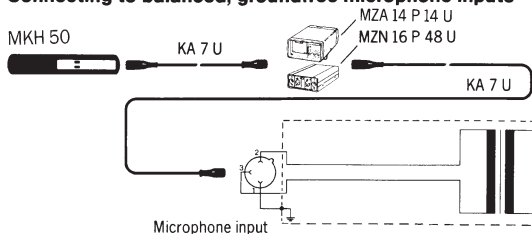

Connecting to unbalanced microphone inputs

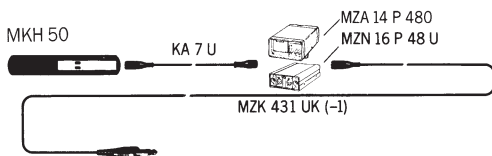

Connecting to mixers and audio recording decks with phantom voltage supply

