

# Professional Video Monitor

## Operating Instructions

Before operating the unit, please read this manual thoroughly and retain it for future reference.

**BVM-HX310**

Software Version 1.0

**TRIMASTER HX 4K HDMI®**

---

# Table of Contents

<b>Precaution .....</b>	<b>3</b>
On Safety .....	3
On Installation .....	3
Connecting to Other Devices .....	3
Handling the Screen .....	3
On the Surface of the Unit .....	3
On Burn-in .....	3
On Image Smearing .....	4
On a Long Period of Use .....	4
On High Brightness Display .....	4
On Fan Error .....	5
On Dew Condensation .....	5
Notes on security .....	5
On Long Periods of Continuous Use .....	5
Handling and Maintenance of the Screen .....	5
Transportation of the Unit .....	5
Disposal of the Unit .....	6
<b>Location and Function of Parts and Controls .....</b>	<b>7</b>
Front Panel .....	7
Input Signals and Adjustable/Setting Items.....	10
Quad View Functions and Adjustable/ Setting Items .....	11
Rear Panel .....	13
Connecting the SDI Signals.....	14
<b>Preventing Falling of the Monitor .....</b>	<b>15</b>
<b>Connecting the AC Power Cord .....</b>	<b>15</b>
<b>Using the Menu .....</b>	<b>16</b>
<b>Protection of the Setting Values .....</b>	<b>17</b>
Protecting the setting values using the KEY INHIBIT button .....	17
Protecting the setting values using Password Lock .....	17
<b>Adjustment Using the Menus .....</b>	<b>18</b>
Items .....	18
Adjusting and Changing the Settings .....	18
Status menu .....	18
User Preset Setting menu .....	19
Color Temp. menu .....	20
User Configuration menu .....	21
Serial Remote menu .....	37
Security menu .....	37
<b>Troubleshooting .....</b>	<b>38</b>
<b>Specifications .....</b>	<b>39</b>
Available Signal Formats .....	40
<b>Dimensions .....</b>	<b>50</b>

The terms HDMI and HDMI High-Definition Multimedia Interface, and the HDMI Logo are trademarks or registered trademarks of HDMI Licensing Administrator, Inc. in the United States and other countries.

---

## Precaution

---

### On Safety

- Operate the unit only with a power source as specified in the "Specifications" section.
- A nameplate indicating operating voltage, etc., is located on the rear panel.
- Should any solid object or liquid fall into the cabinet, unplug the unit and have it checked by qualified personnel before operating it any further.
- Do not drop or place heavy objects on the power cord. If the power cord is damaged, turn off the power immediately. It is dangerous to use the unit with a damaged power cord.
- Unplug the unit from the wall outlet if it is not to be used for several days or more.
- Disconnect the power cord from the AC outlet by grasping the plug, not by pulling the cord.
- The socket-outlet shall be installed near the equipment and shall be easily accessible.

---

### On Installation

- Allow adequate air circulation to prevent internal heat build-up.  
Do not place the unit on surfaces (rugs, blankets, etc.) or near materials (curtains, draperies) that may block the ventilation holes.
- Do not install the unit in a location near heat sources such as radiators or air ducts, or in a place subject to direct sunlight, excessive dust, mechanical vibration or shock.

When installing the installation space must be secured in consideration of the ventilation and service operation.

- Do not block the ventilation slots and vents of the fans.
- Leave a space around the unit for ventilation.
- Leave more than 40 cm of space in the rear of the unit to secure the operation area.

When the unit is installed on the desk or the like, leave at least 10 cm of space in the left and right sides, 10 cm or more of space above the unit.

---

### Connecting to Other Devices

When connecting this unit to other devices, turn off this unit and the other devices beforehand.

Connecting while turned on may cause a malfunction to this unit and the other devices.

---

### Handling the Screen

- The LCD panel fitted to this unit is manufactured with high precision technology, giving a functioning pixel ratio of at least 99.99%. Thus a very small proportion of pixels may be "stuck", either always off (black), always on (red, green, or blue), or flashing. In addition, over a long period of use, because of the physical characteristics of the liquid crystal display, such "stuck" pixels may appear spontaneously. These problems are not a malfunction.
- Do not leave the screen facing the sun as it can damage the screen. Take care when you place the unit by a window.
- Do not push or scratch the monitor's screen. Do not place a heavy object on the monitor's screen. This may cause the screen to lose uniformity.
- Make sure to use the unit without the panel-guard plate during power distribution. Otherwise, panel failure may result due to temperature increase of the panel.
- The screen and the cabinet become warm during operation. This is not a malfunction.

---

### On the Surface of the Unit

The surface of the unit becomes extremely hot. Do not touch the surface with your hand or body during power distribution. It may cause a burn.

---

### On Burn-in

For LCD panel, permanent burn-in may occur if still images are displayed in the same position on the screen continuously, or repeatedly over extended periods.

#### Images that may cause burn-in

- Still images in the HDR display
- Masked images with aspect ratios other than 17:9
- Color bars or images that remain static for a long time
- Character or message displays that indicate settings or the operating state

- On-screen displays such as center markers or area markers
- Images with a frame (including Multi-View displays)

For details on the HDR (High Dynamic Range) display, see "On High Brightness Display" (page 4).

#### **To reduce the risk of burn-in**

- Turn off the character and marker displays  
Press the MENU button to turn off the character displays. To turn off the character or marker displays of the connected equipment, operate the connected equipment accordingly. For details, refer to the operation manual of the connected equipment.
- Do not display static images that contain high brightness display, time codes, markers, or logos for extended periods. Consider applying a display method with low level signals of 100% or less.
- Do not display the images with a frame for a long time. Also, consider removing the frame during the Multi-View display, or displaying the signal level of the frame area by about 50% of the display area.
- Reduce the brightness  
Reduce the brightness as much as possible or reduce the input signal level when you do not use the display.
- Turn off the power when not in use  
Turn off the power if the monitor is not to be used for a prolonged period of time.

#### **Screen saver**

This product has a built-in screen saver function to reduce burn-in. When "Screen Saver" is set to "On" in the "System Setting," the screen brightness will decrease if an almost still image is displayed for more than 30 minutes during the HDR display.

---

## **On Image Smearing**

Due to an LCD's panel structure and characteristics of materials in its design, continuously displaying signals or/and image patterns may cause image smearing or/and flicker on the monitor. If such a problem occurs, perform monitor aging for a while with the video displayed on the monitor.

---

## **On a Long Period of Use**

Due to an LCD's panel structure and characteristics of materials in its design, displaying static images for extended periods, or using the unit repeatedly in a high temperature/high humidity environments may cause image smearing, burn-in, areas of which brightness is permanently changed, lines, or a decrease in overall brightness.

In particular, continually displaying an image smaller than the monitor screen, such as displaying an image in a different aspect ratio or displaying an image with a frame, may expedite the above issues.

Avoid displaying a still image for an extended period, or using the unit repeatedly in a high temperature/high humidity environment such as an airtight room, or around the outlet of an air conditioner.

To prevent any of the above issues, we recommend reducing brightness slightly, and to turn off the power whenever the unit is not in use.

---

## **On High Brightness Display**

- Using the unit with the high brightness display for extended periods may cause eyestrain or reduction of eyesight. Be sure to take an occasional break when using.
- Follow RECOMMENDATION ITU-R BT.1702 "Guidance for the reduction of photosensitive epileptic seizures caused by television" or other guidelines when using.
- In the HDR display, the display surface may emit heat when high brightness images are output. Do not touch the surface.
- When "2.4(HDR)," "S-Log3(HDR)," "S-Log2(HDR)," "SMPTE ST 2084(HDR)," "ITU-R BT.2100(HLG)," or "S-Log3(Live HDR)" is selected for "EOTF" in the "Input Setting" menu, images are displayed in HDR (High Dynamic Range). In this manual, this status is described as "HDR display."
- The HDR display is a method to faithfully display the brightness of signals defined of 100% or more level without compressing the brightness parts.
- You can check the bright portions exceeding the displayable brightness of the unit by decreasing the contrast.

- In the HDR display, the cooling fan is forcibly rotated regardless of outside temperature.

---

## On Fan Error

The unit has a built in fan for cooling. When the fan stops and the  (Power) switch indicator (page 8) blinks in red, turn off the power and contact an authorized Sony dealer.

---

## On Dew Condensation

If the unit is suddenly taken from a cold to a warm location, or if ambient temperature suddenly rises, moisture may form on the outer surface of the unit and/or inside of the unit. This is known as condensation. If condensation occurs, turn off the unit and wait until the condensation clears before operating the unit. Operating the unit while condensation is present may damage the unit.

---

## Notes on security

- SONY WILL NOT BE LIABLE FOR DAMAGES OF ANY KIND RESULTING FROM A FAILURE TO IMPLEMENT PROPER SECURITY MEASURES ON TRANSMISSION DEVICES, UNAVOIDABLE DATA LEAKS RESULTING FROM TRANSMISSION SPECIFICATIONS, OR SECURITY PROBLEMS OF ANY KIND.
- Depending on the operating environment, unauthorized third parties on the network may be able to access the unit. When connecting the unit to the network, be sure to confirm that the network is protected securely.

---

## On Long Periods of Continuous Use

Using this unit for extended periods may cause eyestrain or reduction of eyesight. As soon as you feel physical discomfort or pain, stop using this unit immediately and take a break. If the physical discomfort or pain remains even after taking a break, consult a physician.

---

## Handling and Maintenance of the Screen

The surface of the screen is specially coated to reduce image reflection. Make sure to observe

the following points as improper maintenance procedures may impair the screen's performance. In addition, the screen is vulnerable to damage. Do not scratch or knock against it using a hard object.

- Be sure to disconnect the AC power cord from the AC outlet before performing maintenance.
- The surface of the screen is specially coated. Do not attach adhesive objects, such as stickers, on it.
- The surface of the screen is specially coated. Do not touch the screen directly.
- Wipe the screen surface gently with the supplied cleaning cloth or a soft dry cloth to remove dirt.
- Stubborn stains may be removed with the supplied cleaning cloth, or a soft cloth slightly dampened with a mild detergent solution.
- The screen may become scratched if the cleaning cloth is dusty.
- Never use strong solvents such as alcohol, benzene, thinner, acidic or alkaline detergent, detergent with abrasives, or chemical wipe as these may damage the screen.
- Use a blower to remove dust from the screen surface.

---

## Transportation of the Unit

Do not subject the unit to severe vibration or high impact conditions during transportation. Doing so may result in deformation of the internal structure or exterior of the unit, damage of the screen, malfunction of the internal parts, or other damage. Make sure not to expose the unit to strong vibration or high impact when you transport the unit as cargo by truck, ship, or air, or as luggage with a rolling luggage bag.

### Caution

- This unit is heavy. Make sure to unpack and move the unit with two or more people.
- Firmly grip the bottom of this unit as shown below.

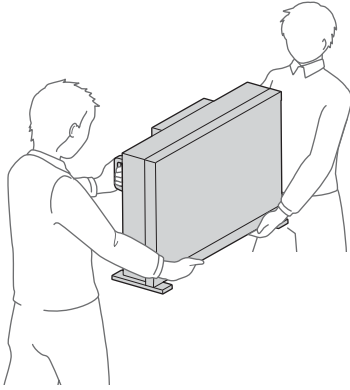

---

## Disposal of the Unit

- Do not dispose of the unit with general waste. Do not include the monitor with household waste.
- When you dispose of the monitor, you must obey the law in the relative area or country.

### Notes

- Always verify that the unit is operating properly before use. SONY WILL NOT BE LIABLE FOR DAMAGES OF ANY KIND INCLUDING, BUT NOT LIMITED TO, COMPENSATION OR REIMBURSEMENT ON ACCOUNT OF THE LOSS OF PRESENT OR PROSPECTIVE PROFITS DUE TO FAILURE OF THIS UNIT, EITHER DURING THE WARRANTY PERIOD OR AFTER EXPIRATION OF THE WARRANTY, OR FOR ANY OTHER REASON WHATSOEVER.
- SONY WILL NOT BE LIABLE FOR CLAIMS OF ANY KIND MADE BY USERS OF THIS UNIT OR MADE BY THIRD PARTIES.
- SONY WILL NOT BE LIABLE FOR THE TERMINATION OR DISCONTINUATION OF ANY SERVICES RELATED TO THIS UNIT THAT MAY RESULT DUE TO CIRCUMSTANCES OF ANY KIND.

# Location and Function of Parts and Controls

## Front Panel

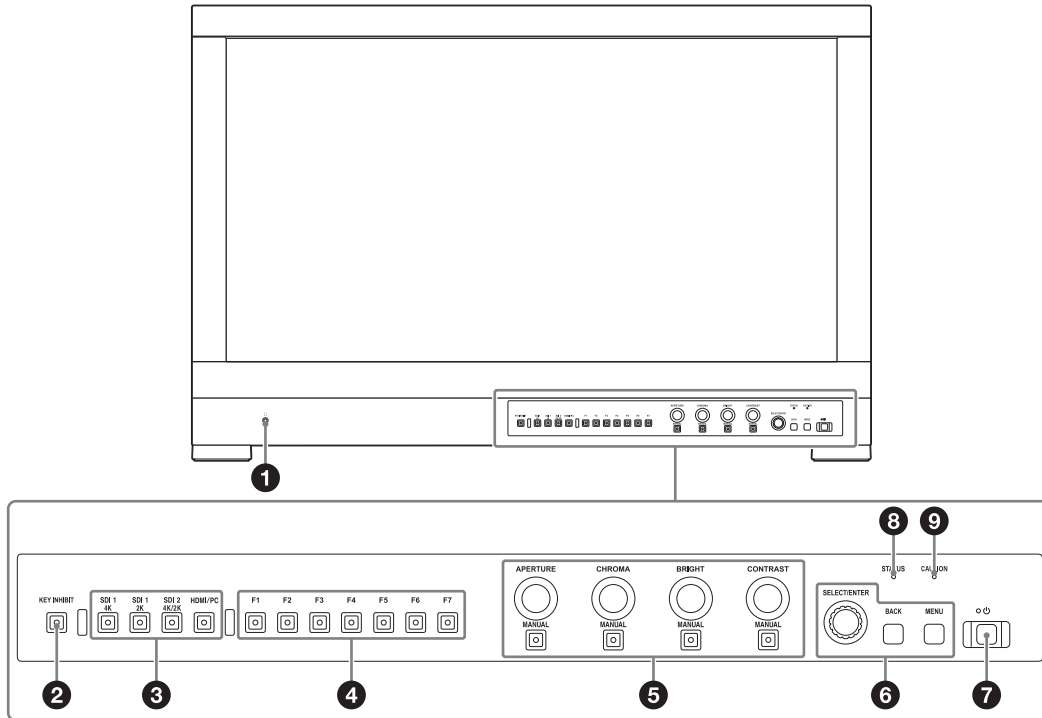

### 1 🎧 (headphones) jack

The audio signal which is selected by the input select button is output in stereo sound. The output audio can be changed in “Audio Setting” (page 31) of the “User Configuration” menu.

### 2 KEY INHIBIT button

You can turn the setting value protection on or off. When the setting value is protected with key inhibit, the value cannot be changed. To change the setting value, turn protection off by pressing the button for more than two seconds.

### 3 Input select buttons

Press to monitor the signal input to each connector.

**SDI1 4K button:** To monitor the 4K signal through the SDI 1 IN connector.

**SDI1 2K button:** To monitor the 2K signal through the SDI 1 IN connector.

**SDI2 4K/2K button:** To monitor the signal through the SDI 2 IN connector.

Select from the menu whether to use as either the SDI2 4K button for monitoring the 4K signal or the SDI2 2K button for monitoring the 2K signal.

For details, see “Input Select” (page 27).

**HDMI/PC button:** To monitor the signal through the HDMI IN connector.

When you sequentially press the buttons that the signal input has already monitored, you can change to the input setting with “Not Skip” selected.

For details, see “Input Setting Skip” (page 24, 27, 28).

### 4 Function buttons

You can turn the assigned function on or off. The factory default settings are following:

**F1 button:** Mono

**F2 button:** Quad View

**F3 button:** Blue Only

**F4 button:** Internal Signal

**F5 button:** Internal Signal Pattern

**F6 button:** Marker

**F7 button:** Time Code

You can assign various functions in “Function Button Setting” (page 29) of the “User Configuration” menu.  
The “Function Button Setting” menu can also be displayed by pressing and holding the function button.

## 5 Rotary encoder

**APERTURE knob:** Adjusts the picture sharpness. Turn the knob to the right to make picture sharper and turn it to the left to make the picture softer. This adjustment is available while the indicator of the MANUAL button below the knob is lit.

**CHROMA knob:** Adjusts the color intensity. Turn the knob to the right to increase the intensity and turn to the left to decrease it. This adjustment is available while the adjustment menu is displayed or the indicator of the MANUAL button below the knob is lit.

**BRIGHT knob:** Adjusts the picture brightness. Turn the knob to the right to increase the brightness and turn to the left to decrease it. This adjustment is available while the adjustment menu is displayed or the indicator of the MANUAL button below the knob is lit.

**CONTRAST knob:** Adjusts the picture contrast. Turn the knob to the right to increase the contrast and turn to the left to decrease it. This adjustment is available while the adjustment menu is displayed or the indicator of the MANUAL button below the knob is lit.

**MANUAL button:** Press to perform the adjustment manually with the knob. Each time the button is pressed, the button indicator lights up or goes out. Each adjustment is available with the knobs above each indicator while it is lit.

## 6 Menu operation buttons

Displays or sets the on-screen menu.

### SELECT/ENTER control

When the menu is displayed, turn the control to select a menu item or setting value, and then press the control to confirm the setting. If the menu is not displayed and the SELECT/ENTER control is pressed, the characters that represent the names of the buttons light up. Also, the names of the functions assigned to the function buttons appear on the screen. Press again to clear it.

Alternatively, if the menu is not displayed and the SELECT/ENTER control is pressed for more than two seconds, the signal format is displayed on the screen.

## BACK button

When the menu is displayed, press the button to reset the value of an item to the previous value (except some items).

## MENU button

Press to display the on-screen menu.  
Press again to clear the menu.

## 7 (Power) switch and indicator

Press to turn on the unit while the main power switch on the rear panel is ON. When the unit turns on, the unit starts up with the indicator flashing in green. When the unit is in operation, the indicator lights in green.  
Press the switch again to turn off the unit. The indicator goes out.

## 8 STATUS indicator

Lights up in blue during HDR display. Slowly flashes in blue when the screen saver displaying in HDR starts up, and quickly flashes in blue when a warning during startup occurs.  
For details on the HDR (High Dynamic Range) display, see “On High Brightness Display” (page 4).

## 9 CAUTION indicator

Flashes in amber when the brightness decreases due to abnormal temperature.

## About error/warning signals of the indicator

While the unit is in use, the  (Power) switch indicator or CAUTION indicator of the front panel may show error or warning signals.  
If an error display appears, refer to Sony qualified service personnel.

## Error display

CAUTION indicator	Power indicator	Symptom
–	Flashes in red (every second)	Power abnormality, circuit board abnormality, sensor abnormality
–	Flashes in red (every two seconds)	Fan abnormality, circuit board abnormality

## Warning display

CAUTION indicator	Power indicator	Symptom
Flashes in amber (every second) <sup>1)</sup>	–	Decreases the brightness to protect the panel from overheating

1) When using in the HDR display, regardless of the input signal, the screen brightness may decrease when the

protective function for the LCD panel activates. Keep the temperature of the peripheral environment of the unit around 25 °C (77 °F) to avoid brightness decrease due to the protection function. For the installation environment of the unit, see "On Installation" (page 3).  
For details on the HDR (High Dynamic Range) display, see "On High Brightness Display" (page 4).

## About operations using the Sony monitor control unit (the controller)

When the optional controller (BKM-16R or BKM-17R) is connected, the following operations are available with the buttons of the controller.  
For details on each function, see "Adjustment Using the Menus" (page 18).

### Menu operation buttons

Button	Operations
MENU button	When the on-screen menu is not displayed, press the button to display the menu. Press again to clear the menu. When the menu is displayed, press the button to reset the value of an item to the previous value.
ENTER button	When the menu is displayed, press the button to confirm a menu item or setting value.  However, displaying the signal format by pressing and holding the button is not available.
UP button	When the menu is displayed, press the button to select a menu item or setting value.
DOWN button	

### Power button

Button	Operations
MONITOR   / ⏻	Switches the operating mode of the monitor. Press the button for the sleep mode when the monitor is in the operating mode. The power indicator on the front panel lights in red. Press the button for the operating mode when the monitor is in the sleep mode.

### Rotary encoder/MANUAL buttons

Knob	Operations
CONTRAST knob	Adjusts the picture contrast.
BRIGHT knob	Adjusts the picture brightness.
CHROMA knob	Adjusts the color intensity.
PHASE knob	Available only in the color temperature adjusting menu. No other operations are available.

Button	Operations
CONTRAST MANUAL button	Press the button to adjust contrast manually.
BRIGHT MANUAL button	Press the button to adjust brightness manually.
CHROMA MANUAL button	Press the button to adjust color intensity manually.
PHASE MANUAL button	Available only in the color temperature adjusting menu. No other operations are available.

### Numeric buttons

Button	Operations
1 to 9 button	Turns on or off functions assigned to the numeric buttons from 1 to 9 on the controller. The factory default settings are following: 1 button: SDI1 4K 2 button: SDI1 2K 3 button: SDI2 4K 4 button: SDI2 2K 5 button: HDMI 6 button: Native Scan 7 button: Internal Signal 8 button: Internal Signal Pattern 9 button: Marker Each function can be assigned at "Function/Numeric Button Setting" (page 37) of the "Serial Remote" menu.
Ent button	Operates similar to the ENTER button on the controller.

### Function buttons

Button	Operations
F1 to F16 button	Turns on or off functions assigned to the function buttons on the controller. The following functions are available. Mono, Blue Only, R Off, G Off, B Off, Character Off, Native Scan, Interlace, Aperture (selecting the manually adjusted setting in Aperture), Marker, Aspect Marker, Area Marker1, Area Marker2, Center Marker, Aspect Marker-Line, Aspect Blanking-Black, Aspect Blanking-Half

#### Note

Up to a total of three controller units (including BKM-16R and BKM-17R) can be simultaneously connected to a BVM-HX310 unit.

## Input Signals and Adjustable/Setting Items

Item	Input signal							
	SDI 1/2 4K			SDI 1/2 2K			HDMI	
	YCbCr	RGB	XYZ	YCbCr	RGB	XYZ	YCbCr	RGB
APERTURE	○	○	×	○	○	×	○	○
CHROMA <sup>1)</sup>	○	○	×	○	○	×	○	○
BRIGHT	○	○	○	○	○	○	○	○
CONTRAST <sup>2)</sup>	○	○	○	○	○	○	○	○
User Preset	○	○	○	○	○	○	○	○
Color Temp.	○	○	○	○	○	○	○	○
Manual Adjustment (Color Temp.)	○	○	○	○	○	○	○	○
Screen Saver <sup>3)</sup>	○	○	○	○	○	○	○	○
RGB Range	×	○	×	×	○	×	×	○
YCC Range	×	×	×	×	×	×	○	×
Color Space	○	○	×	○	○	×	○	○
EOTF	○	○	×	○	○	×	○	○
Transfer Matrix	○	×	×	○	×	×	○	×
Internal Signal	○	○	×	○	○	×	○	○
Internal Signal Pattern	○	○	×	○	○	×	○	○
Mono <sup>4)</sup>	○	○	○	○	○	○	○	○
Blue Only	○	○	○	○	○	○	○	○
R Off	○	○	○	○	○	○	○	○
G Off	○	○	○	○	○	○	○	○
B Off	○	○	○	○	○	○	○	○
Character Off	○	○	○	○	○	○	○	○
Interlace <sup>5)</sup>	×	×	×	○	○	○	○	○
Native Scan	○	○	○	○	○	○	○	○
1080I/PsF <sup>6)</sup>	×	×	×	○	○	○	×	×
Area and Aspect Marker	○	○	○	○	○	○	○	○
Gamut Marker <sup>7)</sup>	○	○	×	○	○	×	○	○
Input Setting	○	○	○	○	○	○	○	○
Time Code	○	○	○	○	○	○	×	×
Volume	○	○	○	○	○	○	○	○
Audio Muting	○	○	○	○	○	○	○	○
Relative Contrast 1/2, Relative Contrast 1/3, Relative Contrast 1/4 <sup>8)</sup>	○	○	○	○	○	○	○	○
User LUT <sup>9)</sup>	○	○	×	○	○	×	×	×

○ : Adjustable/can be set

×

- 1) When the EOTF is set to "S-Log3(HDR)," "S-Log2(HDR)," "SMPTE ST 2084(HDR)," "ITU-R BT.2100(HLG)," or "S-Log3(Live HDR)," this does not function.
- 2) The available maximum brightness is reduced by half when the interlace display is selected.
- 3) Available only during HDR (High Dynamic Range) display.
- 4) When the RGB signal is input, the brightness signal based on the transfer matrix selected in "Transfer Matrix" is displayed.
- 5) The setting is available when 50I, 59.94I, 60I, 25PsF, 29.97PsF, or 30PsF signals are input in the SDI 2K input and the interlace process is selected in the "1080I/PsF" setting.
- 6) The setting is available when 50I, 59.94I, 60I, 25PsF, 29.97PsF, or 30PsF signals are input in the SDI 2K input.
- 7) The setting is available while "ITU-R BT.2020" is selected for "Color Space."

8) This setting is available only when the EOTF is set to "2.4(HDR)," "S-Log3(HDR)," "S-Log2(HDR)," "SMPTE ST 2084(HDR)," "ITU-R BT.2100(HLG)," or "S-Log3(Live HDR)."

9) Available only for SDI 2 input.

## Quad View Functions and Adjustable/Setting Items

Item	Function	
	Quad View <sup>2)</sup>	
	Common setting for four views	Individual setting for each view
APERTURE	○	○ <sup>3)</sup>
CHROMA <sup>1)</sup>	○	○ <sup>3)</sup>
BRIGHT	×	○ <sup>3)</sup>
CONTRAST	×	○ <sup>3)</sup>
User Preset	×	○
Color Temp.	×	○ <sup>3)</sup>
Manual Adjustment (Color Temp.)	○	○ <sup>3)</sup>
Screen Saver	○	×
RGB Range	○	○ <sup>4)</sup>
YCC Range	○	○ <sup>4)</sup>
Color Space	○	○ <sup>4)</sup>
EOTF	○	○ <sup>4)</sup>
Transfer Matrix	○	○ <sup>4)</sup>
Internal Signal	×	×
Internal Signal Pattern	×	×
Mono	×	×
Blue Only	○	×
R Off	○	×
G Off	○	×
B Off	○	×
Character Off	○	×
Interlace	×	×
Native Scan	×	×
1080i/PsF	○	×
Area and Aspect Marker	×	×
Gamut Marker	×	×
Input Setting	×	○
Time Code	○ <sup>5)</sup>	×
Volume	○ <sup>6)</sup>	×
Audio Muting	○	×
Relative Contrast 1/2, Relative Contrast 1/3, Relative Contrast 1/4	○	×
User LUT <sup>7)</sup>	○	○ <sup>4)</sup>

○ : Adjustable/can be set

×

1) When the EOTF is set to "S-Log3(HDR)," "S-Log2(HDR)," "SMPTE ST 2084(HDR)," "ITU-R BT.2100(HLG)," or "S-Log3(Live HDR)," this does not function.

2) The signal equivalent to HDMI 4K cannot be displayed with Quad View.

3) To individually switch the setting, set each "User Preset" to "Input Setting" and set each "Input Setting" to each view.

4) To individually switch the setting, set each to "Input Setting" and set each "Input Setting" to each view.

- 5) Only the Time Code of the signal that is input on Screen A is displayed during Quad View.
- 6) The audio signal input on Screen A is output during Quad View.
- 7) Available only for SDI 2 input.

## Rear Panel

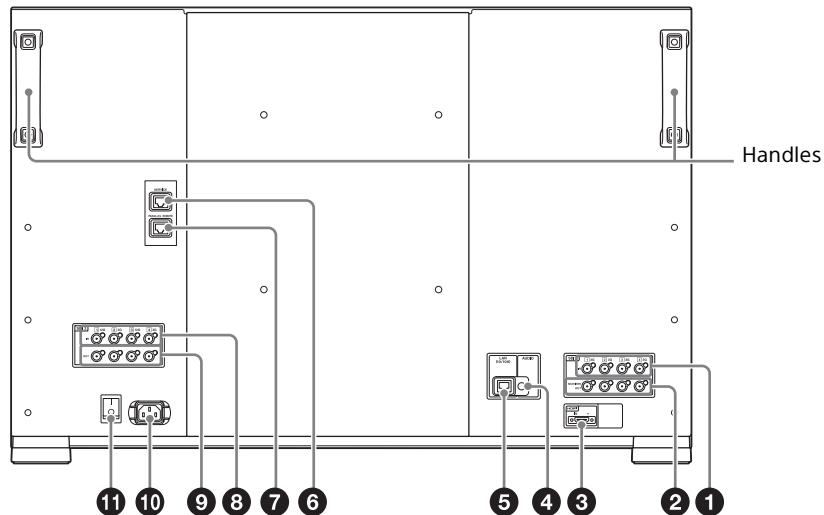

### 1 SDI 1 IN (SDI 1 input) connectors (BNC)

Input connectors for serial digital signals.  
For details, see “Connecting the SDI Signals” (page 14).

### 2 MONITOR OUT (SDI output) connectors (BNC)

Output connectors for serial digital signals.  
Outputs the signal that is input to the SDI 1 IN connector when the SDI 1 IN connector signal is displayed.  
The 1 to 4 connectors output the signal that is input to the corresponding SDI 1 IN connector.  
Outputs the signal that is input to the SDI 2 IN connector when the 3G or HD-SDI signal of SDI 2 IN connector is displayed. When using the User LUT function, the signal is output after it is converted to the different signal level from that of the input signal.  
The 1 to 4 connectors output the signal that is input to the corresponding SDI 2 IN connector.  
Outputs the signal that is input to the previously displayed SDI 1 IN/SDI 2 IN connector when the HDMI IN connector signal is displayed.

#### Note

SDI output is not activated when the unit is turned off.

### 3 HDMI IN (HDMI input) connector

Input connector for HDMI signals.  
HDMI (High-Definition Multimedia Interface) is an interface that supports both video and audio on a single digital connection, allowing you to enjoy high quality digital picture and sound. The

HDMI specification supports HDCP (High-bandwidth Digital Content Protection), a copy protection technology that incorporates coding technology for digital video signals.

#### Note

To input the HDMI signal equivalent to 4K, use an HDMI cable bearing the Premium High Speed logo within a length of 3 meters (Sony product recommended).  
To input other signals, we recommend using a Premium High Speed HDMI cable within a length of 3 meters.

### 4 AUDIO output connector (stereo mini jack)

The audio signal of the input signal which is selected by the input select button on the front panel is output.  
The output audio signal can be changed in “Audio Setting” (page 31) of the “User Configuration” menu.

### 5 LAN (10/100) connector

Connect to the controller by using a 10BASE-T/100BASE-TX LAN cable (shielded type, optional).

#### Note

The connection speed may be affected by the network system. This unit does not guarantee the communication speed or quality of 10BASE-T/100BASE-TX.

### 6 SERVICE connector

Used for services.

### 7 PARALLEL REMOTE connector

Used for future expansion. It is currently unavailable.

### 8 SDI 2 IN (SDI 2 input) connectors (BNC)

Input connectors for serial digital signals. For details, see "Connecting the SDI Signals" (page 14).

#### Note

When the 12G-SDI or 6G-SDI signal is input to the SDI 2 IN connectors, the 12G-SDI cable (L-5.5CUHD manufactured by Canare Electric Co., Ltd. or an equivalent cable) is recommended.

### 9 SDI 2 OUT (SDI 2 output) connectors (BNC)

Output connectors for serial digital signals.

The 1 to 4 connectors output the signal that is input to the corresponding SDI 2 IN connector.

#### Notes

- SDI output is not activated when the unit is turned off.
- When the 12G-SDI or 6G-SDI signal is output from the SDI 2 OUT connectors, the 12G-SDI cable (L-5.5CUHD manufactured by Canare Electric Co., Ltd. or an equivalent cable) is recommended.

### 10 AC IN socket

Connect the supplied AC power cord.

### 11 Main power switch

Press I to provide power supply to the unit.

## Connecting the SDI Signals

The following signals can be input to the SDI 1 IN and SDI 2 IN connectors of this unit.

Input signal			Connector		Maximum
			SDI 1 IN	SDI 2 IN	
Single Link	3G/HD-SDI	-	1 to 4	1 to 4	8 channels
	12G/6G-SDI	-	-	1, 3	2 channels
Dual Link	3G/HD-SDI	3G/HD-SDI Link 1	1	1	4 channels
		3G/HD-SDI Link 2	2	2	
		3G/HD-SDI Link 1	3	3	
		3G/HD-SDI Link 2	4	4	
Quad Link (2-sample interleave division)	3G/HD-SDI	3G-SDI Link 1	1	1	2 channels
		3G-SDI Link 2	2	2	
		3G-SDI Link 3	3	3	
		3G-SDI Link 4	4	4	
Quad Link (Square division)	3G/HD-SDI	Mapping signal of Sub image 1 (upper-left screen)	1	1	2 channels
		Mapping signal of Sub image 2 (upper-right screen)	2	2	
		Mapping signal of Sub image 3 (lower-left screen)	3	3	
		Mapping signal of Sub image 4 (lower-right screen)	4	4	

## Preventing Falling of the Monitor

- 1 Tie a piece of stout string (commercially available) to the left and right handles of the monitor.

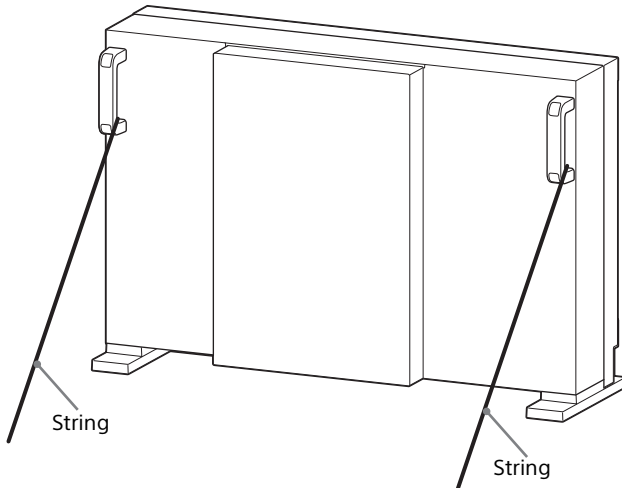

- 2 Secure the ends of the string to the floor or wall.

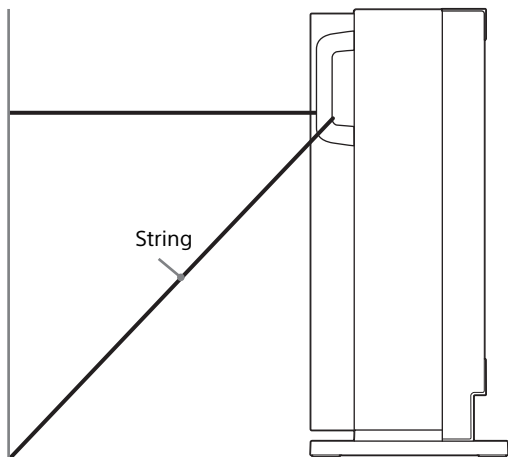

## Connecting the AC Power Cord

- 1 Plug the AC power cord into the AC IN socket on the rear panel. Then, attach the AC plug holder (supplied) to the AC power cord.

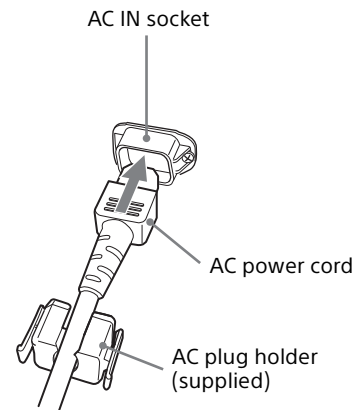

- 2 Slide the AC plug holder over the cord until it locks.

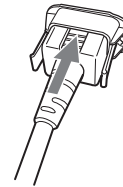

### To remove the AC power cord

Pull out the AC plug holder while pressing the lock levers.

# Using the Menu

Various adjustments and settings, such as picture quality adjustment, input signals setting, and default setting change, are made on the menu screen of the unit.

The current settings are displayed in place of the ■■■ marks on the illustrations of the menu screen.

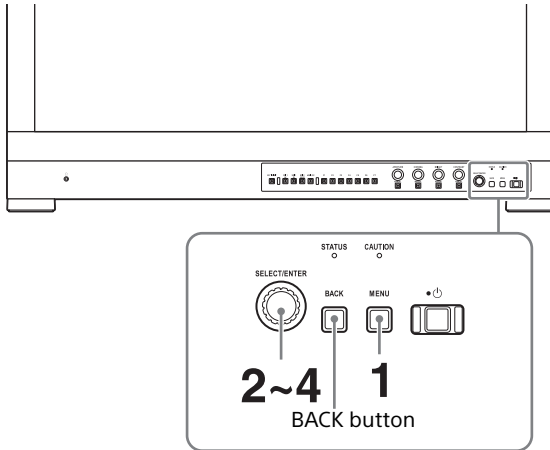

- 1 Press the MENU button.

The menu appears.  
The menu presently selected is shown in yellow.

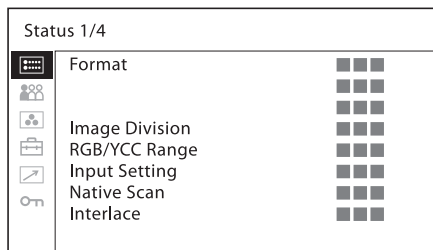

- 2 Turn the SELECT/ENTER control to select a menu, then press the SELECT/ENTER control.

The menu icon presently selected is shown in yellow and setting items are displayed.

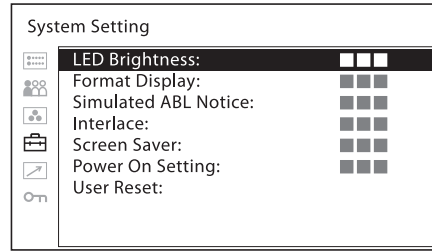

- 3 Turn the SELECT/ENTER control to select the item, then press the SELECT/ENTER control.

The selected item is displayed in yellow.  
If the menu consists of multiple pages, turn the SELECT/ENTER control to go to the desired menu page.

- 4 Make the setting or adjustment on an item.

### When changing the adjustment level:

To increase the number, turn the SELECT/ENTER control right.  
To decrease the number, turn the SELECT/ENTER control left.  
Press the SELECT/ENTER control to confirm the number, then restore the original screen.

### When changing the setting:

Turn the SELECT/ENTER control to change the setting, then press the SELECT/ENTER control to confirm the setting.

### When returning the adjustment or setting to the previous value:

Press the BACK button before pressing the SELECT/ENTER control.

### Notes

- An item displayed in black cannot be accessed. You can access the item if it is displayed in white.
- If the "Password Lock" has been turned "On," the setting values of the color temperature for "User1" and the User Preset for "User Preset1" cannot be changed. To change the values, enter the password.  
For details on the password lock function, see "Security menu" (page 37).

### To return the display to the previous screen

Press the BACK button.

### To clear the menu

Press the MENU button.

The menu disappears automatically if a button is not pressed for one minute.

### **About the memory of the settings**

The settings are automatically stored in the monitor memory.

---

## **Protection of the Setting Values**

---

### **Protecting the setting values using the KEY INHIBIT button**

You can protect the setting values using the KEY INHIBIT button (page 7).

When the values are protected by the key inhibit function, you cannot change the values. To change the values, press and hold the KEY INHIBIT button for more than two seconds to set the protection of the setting value to off.

---

### **Protecting the setting values using Password Lock**

You can protect the setting values of the color temperature for "User1" and the User Preset for "User Preset1" using "Password Lock."

When the values are protected with a password, you need to enter the password during the following operations.

- When you change the color temperature values for "User1" using "Adjust Gain/Bias" or "Copy From."
- When you change the User Preset values for "User Preset1."

For details, see "Password Lock" (page 38).

---

# Adjustment Using the Menus

---

## Items

The screen menu of this monitor consists of the following items.

### **Status (the items indicate the current settings.) (page 18)**

Displays the unit setting status, etc.  
For details on the displayed items, see "Status menu" (page 18).

### **User Preset Setting (page 19)**

- User Preset
  - Color Temp.
  - Contrast
  - Brightness
  - Chroma
  - Aperture
  - Volume
  - Marker Preset
- Copy From

### **Color Temp. (page 20)**

- Color Temp.
  - R/G/B Gain
  - R/G/B Bias
- Manual Adjustment
  - Adjust Gain/Bias
  - Signal
- Copy From

### **User Configuration (page 21)**

- System Setting
  - LED Brightness
  - Format Display
  - Simulated ABL Notice
  - Interlace
  - Screen Saver
  - Power On Setting
  - User Reset
- Input Setting
  - SDI1 4K/UHD Input Setting
  - SDI1 2K/HD Input Setting
  - Input Select
    - SDI2 4K/UHD Input Setting
    - SDI2 2K/HD Input Setting
  - HDMI Input Setting
- Function Button Setting

- Audio Setting
  - SDI Audio Setting
- Internal Signal Setting
  - Internal Signal
  - Pattern
- Gamut Marker Setting
  - Gamut Marker
  - Target
  - Type
- Area and Aspect Marker Setting
  - Marker Preset
- Time Code Setting
  - Time Code
  - Format
  - Position
  - Transparency
- Quad View Setting
  - Quad View Display
  - Input Port
  - Screen Setting
- User LUT Setting
  - Load LUT
  - Delete LUT

### **Serial Remote (page 37)**

- Monitor
  - Network Setting
  - Connection
- Controller
  - Network Setting
  - Function/Numeric Button Setting

### **Security (page 37)**

- Password Lock
  - Color Temp./User Pre.
  - Change Password

---

## Adjusting and Changing the Settings

### **Status menu**

The status menu displays the current status of the unit. The following items are displayed:

#### **Note**

Title displays in the "Status" menu differ during Quad View.

## Page 1

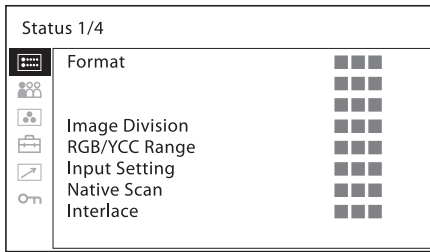

## Page 2

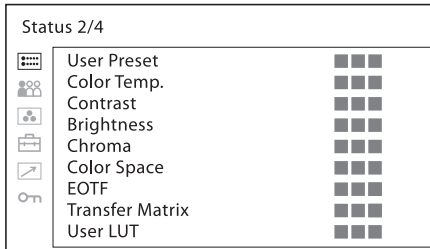

## Page 3 (for the SDI signal input)

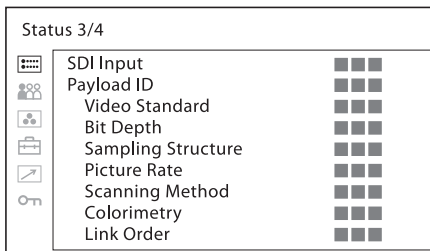

## Page 3 (for the HDMI signal input)

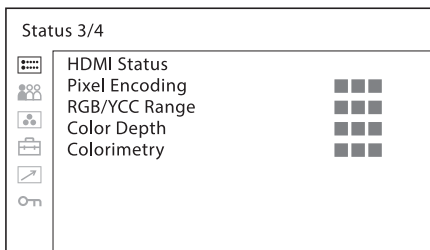

## Page 4

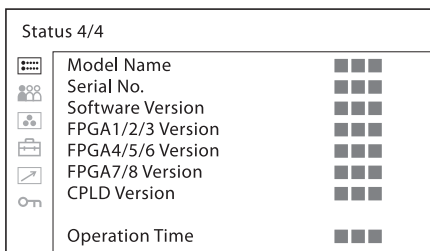

## User Preset Setting menu

You can set and adjust various items in the User Preset. The preset values can be copied from other preset data.

To apply the User Preset settings and adjustments in this menu, select User Preset in the "Input Setting" menu (page 24, 26, 28).

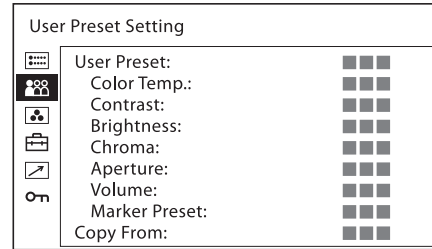

Submenu	Setting
User Preset	Select the User Preset data to be set. <ul style="list-style-type: none"> <li>• User Preset1 (Default value)</li> <li>• User Preset2</li> <li>• User Preset3</li> <li>• User Preset4</li> <li>• User Preset5</li> <li>• User Preset XYZ</li> </ul>

### Note

When the XYZ format signal is input, set to "User Preset XYZ."

Color Temp.

Select the color temperature to be used in the selected User Preset.

- D65 <sup>1)</sup> (Default value)
- D93 <sup>1)</sup>
- D61 <sup>1)</sup>
- D55 <sup>1)</sup>
- DCI
- User1 <sup>2)</sup> <sup>3)</sup>
- User2 <sup>2)</sup> <sup>3)</sup>
- User3 <sup>3)</sup>
- User4 <sup>3)</sup>
- User5 <sup>3)</sup>
- DCI XYZ

### Note

When the XYZ format signal is input, set to "DCI XYZ."

Contrast

Set the contrast of the selected User Preset. (Default value: 400) <sup>4)</sup>

Brightness

Set the brightness of the selected User Preset. (Default value: 0) <sup>4)</sup>

Submenu	Setting
Chroma	Set the chroma level of the selected User Preset. (Default value: 1000) <sup>4)</sup>
<b>Note</b>	
When "S-Log3(HDR)," "S-Log2(HDR)," "SMPTE ST 2084(HDR)," "ITU-R BT.2100(HLG)," or "S-Log3(Live HDR)" is selected for "EOTF" in the "Input Setting" menu, the chroma level setting is not applied. For details on the EOTF setting, see page 23.	
Aperture	Set the aperture of the selected User Preset. (Default value: 0)
Volume	Adjusts the volume of the selected User Preset. (Default value: 30)
Marker Preset	Select the marker preset to be used in the selected User Preset. <ul style="list-style-type: none"> <li>• Marker Preset1 (Default value)</li> <li>• Marker Preset2</li> <li>• Marker Preset3</li> <li>• Marker Preset4</li> <li>• Marker Preset5</li> </ul>
Copy From	Copies the other User Preset data to the selected User Preset. The appropriate settings are saved in "Default(D65)" for D65, "Default(D93)" for D93, and "Default(XYZ)" for XYZ format signal. <ul style="list-style-type: none"> <li>• User Preset1</li> <li>• User Preset2</li> <li>• User Preset3</li> <li>• User Preset4</li> <li>• User Preset5</li> <li>• Default(D65) (Default value)</li> <li>• Default(D93)</li> <li>• User Preset XYZ</li> <li>• Default(XYZ)</li> </ul>

- 1) If you measure the color temperatures of different display types, such as CRT, LCD, or OLED, by using a common (or general) color analyzer that is based on CIE 1931, and adjust the xy chromaticity to the same value, the appearance may be different because of optical spectrum differences. To compensate for this difference, the "D65," "D93," "D61," and "D55" settings of the monitor are adjusted by a color matching-adjusted offset for CRT and BVM-X300. (The offset value (x -0.006, y -0.011) is applied to the CIE 1931 (x, y) value.)
- 2) Chromaticity points of D65 and D93 without an offset are indicated as default values. (The values (x=0.313, y=0.329) and (x=0.283, y=0.297) are indicated based on the CIE 1931 (x, y) value.)
- 3) Chromaticity point of D65 without an offset can be set by respectively setting the R (Red)/G (Green)/B (Blue) gain value to 1000. (The value (x=0.313, y=0.329) can be set based on the CIE 1931 (x, y) value.)
- 4) If you select each setting item while the MANUAL button is turned on, the MANUAL button is turned off and the manually set value is copied.

### Color Temp. menu

You can select and adjust the color temperature.

You need to use the measurement instrument to adjust the white balance.

Recommended: Konica Minolta Color Analyzer CA-310/410

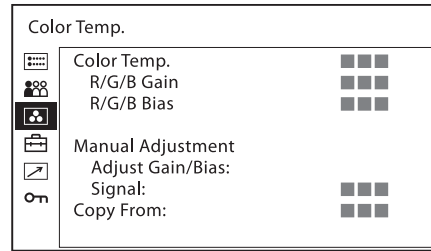

Submenu	Setting
Color Temp.	The current setting status of the color temperature is displayed.
Manual Adjustment	If you set the "Color Temp." to the "User1" to "User5" setting, you can adjust the color temperature.
Adjust Gain/Bias	Adjusts the color balance. <ul style="list-style-type: none"> <li>• <b>Gain:</b> Adjusts the color balance (gain) of R (red)/G (green)/B (blue).</li> <li>• <b>Bias:</b> Adjusts the color balance (bias) of R (red)/G (green)/B (blue). (Default value: 0)</li> </ul>
Signal	Select the signal to adjust the white balance. <ul style="list-style-type: none"> <li>• <b>Internal:</b> Select to adjust the white balance by using the internal signal. When the XYZ format signal is input, the internal signal is displayed as D65 48cd/m<sup>2</sup>. (Default value)</li> <li>• <b>External:</b> Select to adjust the white balance by using the signals input from an external device.</li> </ul>

Submenu	Setting
Copy From	Select from the following items to copy the white balance data of the selected color temperature. <ul style="list-style-type: none"> <li>• D65 (Default value)</li> <li>• D93</li> <li>• D61</li> <li>• D55</li> <li>• DCI</li> <li>• User1</li> <li>• User2</li> <li>• User3</li> <li>• User4</li> <li>• User5</li> <li>• DCI XYZ</li> </ul>
<p><b>Notes</b></p> <ul style="list-style-type: none"> <li>• If "Password Lock" has been turned "On," the "User1" value is protected by a password. To change the values, enter the password.</li> <li>• The color temperature data is used commonly regardless of the signal format or the EOTF setting. When the color temperature is adjusted under certain conditions, the adjusted result is reflected in all displays on which the same color temperature data is set.</li> </ul>	

## User Configuration menu

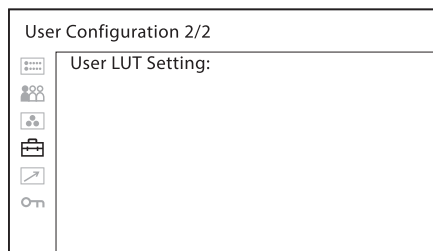
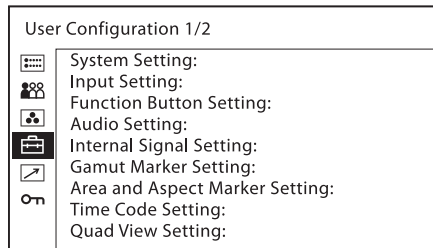

## System Setting

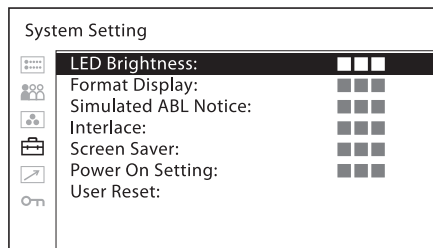

Submenu	Setting
LED Brightness	Selects the brightness of the indicator's LED of the buttons, power switch, etc. <ul style="list-style-type: none"> <li>• <b>High:</b> The level of the LED brightness becomes high. (Default value)</li> <li>• <b>Middle:</b> The level of the LED brightness becomes medium. The level of the character's brightness which shows the button name is "High" or "Low." When "Middle" is selected, the brightness is set to the same as "Low."</li> <li>• <b>Low:</b> The level of the LED brightness becomes low.</li> </ul>
Format Display	Selects the display mode of the signal format. <ul style="list-style-type: none"> <li>• <b>Auto:</b> The format is displayed for about five seconds when the input of the signal starts. (Default value)</li> <li>• <b>Off:</b> The display is hidden.</li> </ul>
Simulated ABL Notice	Simulates the ABL (Automatic Brightness Limiter) performance of Professional Video Monitor BVM-X300. Set whether to display "Simulated ABL" on the screen when ABL is being activated (the screen brightness is lowered) on BVM-X300. <ul style="list-style-type: none"> <li>• <b>On:</b> "Simulated ABL" is displayed.</li> <li>• <b>Off:</b> "Simulated ABL" is not displayed. (Default value)</li> </ul>

### Note

This function provides a rough indication of the ABL performance of BVM-X300. When the monitor and BVM-X300 are used side by side, the display timing between "Simulated ABL" on the monitor and the ABL performance of BVM-X300 may not be matched exactly.

Interlace	The interlace signal is displayed as the interlace picture by inserting the black line without I/P conversion processing. A picture faithful to the original signal with the same feel as a CRT is gained. <ul style="list-style-type: none"> <li>• <b>On:</b> Interlaced video is displayed. (Default value)</li> <li>• <b>Off:</b> The progressive signals by I/P conversion processing are displayed.</li> </ul>
-----------	---------------------------------------------------------------------------------------------------------------------------------------------------------------------------------------------------------------------------------------------------------------------------------------------------------------------------------------------------------------------------------------------------------------------

### Note

The brightness of HDR display is reduced by half when the interlace display is selected. Except for HDR display, the normal brightness is set by increasing the value of gain. However, the maximum brightness is reduced by half.

Submenu	Setting
Screen Saver	<p>Sets the screen saver function On or Off.</p> <ul style="list-style-type: none"> <li>• <b>On:</b> If a still image is displayed for more than 30 minutes, the brightness of the screen is automatically decreased to reduce burn-in. The screen returns to normal brightness when you input a video signal to the unit or operate the buttons on the front panel of the unit. While the screen saver is active, the STATUS indicator flashes every two seconds. Before the screen saver starts up, the STATUS indicator flashes every second to notify users that the screen saver will start up. (Default value)</li> <li>• <b>Off:</b> The screen saver function is deactivated.</li> </ul> <p><b>Note</b></p> <p>In the SDR (Standard Dynamic Range) display, this setting is forcibly set to "Off."</p>
Power On Setting	<p>Sets this unit's setting status after the unit is turned on.</p> <ul style="list-style-type: none"> <li>• Last Memory (Default value)</li> <li>• Input Setting1</li> <li>• Input Setting2</li> <li>• Input Setting3</li> <li>• Input Setting4</li> <li>• Input Setting5</li> <li>• Input Setting6</li> <li>• Input Setting7</li> <li>• Input Setting8</li> </ul>
User Reset	<p>Returns to the factory default setting.</p> <ul style="list-style-type: none"> <li>• <b>Cancel:</b> Cancels reset.</li> <li>• <b>Confirm:</b> Resets the unit.</li> </ul> <p><b>Note</b></p> <p>The following are not reset to the default setting even when User Reset is performed.</p> <ul style="list-style-type: none"> <li>• Color temperature for User1 to User5</li> <li>• User Preset for User Preset1</li> <li>• Network setting of the monitor</li> <li>• Password setting</li> </ul>

## Input Setting

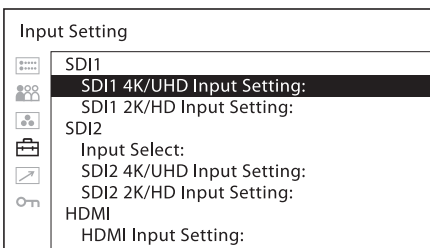

## SDI1 4K/UHD Input Setting / SDI2 4K/UHD Input Setting

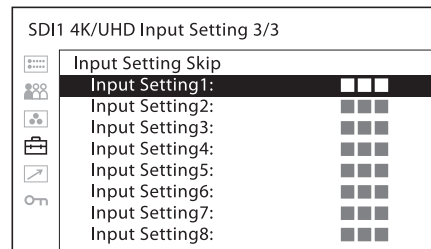
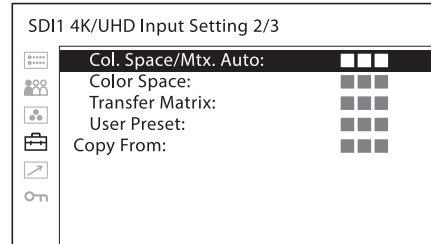
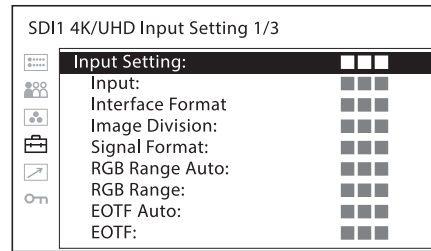

### Note

In the "SDI2 4K/UHD Input Setting" menu, submenu items displayed on the "SDI2 4K/UHD Input Setting 2/3" screen differ.

Submenu	Setting
Input Setting	<p>Sets the input setting of the SDI 4K signal. The input settings from "Input Setting1" to "Input Setting8" can be individually set for the SDI1 4K and SDI2 4K signals.</p> <ul style="list-style-type: none"> <li>• Input Setting1 (Default value)</li> <li>• Input Setting2</li> <li>• Input Setting3</li> <li>• Input Setting4</li> <li>• Input Setting5</li> <li>• Input Setting6</li> <li>• Input Setting7</li> <li>• Input Setting8</li> </ul>

Submenu	Setting
Input	<p>Set the input connector of the SDI 4K signal.</p> <ul style="list-style-type: none"> <li>• <b>Input1,2,3&amp;4:</b> Select to use SDI IN [1], SDI IN [2], SDI IN [3], and SDI IN [4] with Quad Link. (Default value)</li> <li>• <b>Input1&amp;2:</b> Select to use SDI IN [1] and SDI IN [2] with Dual Link.</li> <li>• <b>Input3&amp;4:</b> Select to use SDI IN [3] and SDI IN [4] with Dual Link.</li> <li>• <b>Input1 1):</b> Select to use SDI 2 IN [1] with Single Link.</li> <li>• <b>Input3 1):</b> Select to use SDI 2 IN [3] with Single Link.</li> </ul> <p>1) Displayed only on the "SDI2 4K/UHD Input Setting" menu. Select this when the 12G/6G-SDI signal is input.</p>
Interface Format	<p>Displays the interface format of the SDI 4K signal.</p> <ul style="list-style-type: none"> <li>• Quad-Link 3G/HD-SDI (Default value)</li> <li>• Dual-Link 3G-SDI</li> <li>• Single-Link 12G/6G-SDI 1)</li> </ul> <p>1) Displayed only on the "SDI2 4K/UHD Input Setting" menu.</p>
Image Division	<p>Set the image division of the SDI 4K signal.</p> <ul style="list-style-type: none"> <li>• <b>Auto:</b> Select for the Auto setting. (Default value)</li> <li>• <b>2SI:</b> Select to receive images of the 2 sample Interleave system.</li> <li>• <b>Square:</b> Select to receive images of the Square system.</li> </ul>
Signal Format	<p>Select from the following when "Interface Format" is set to "Quad-Link 3G/HD-SDI" or "Single-Link 12G/6G-SDI."</p> <ul style="list-style-type: none"> <li>• Auto (Default value)</li> <li>• 422 YCbCr 10bit</li> <li>• 444 RGB 10bit</li> <li>• 444 YCbCr 10bit</li> <li>• 444 RGB 12bit</li> <li>• 444 YCbCr 12bit</li> <li>• 444 XYZ 12bit</li> </ul> <p>"422 YCbCr 10bit" is set when "Interface Format" is set to "Dual-Link 3G-SDI."</p>
RGB Range Auto	<p>Select how to set the RGB Range.</p> <ul style="list-style-type: none"> <li>• <b>On:</b> Use the RGB Range according to the input signal information. (Default value)</li> <li>• <b>Off:</b> Use the RGB Range that was set in "RGB Range."</li> </ul>

Submenu	Setting
RGB Range	<p>Select from the following when "RGB Range Auto" is set to "Off" and the RGB signal is input.</p> <ul style="list-style-type: none"> <li>• <b>Full:</b> 0 to 1023 (10bit) / 0 to 4095 (12bit)</li> <li>• <b>Limited:</b> 64 to 940 (10bit) / 256 to 3760 (12bit)</li> <li>• <b>SDI Full Range 1):</b> 4 to 1019 (10bit) / 16 to 4076 (12bit)</li> </ul> <p>1) This manual regards the Full Range signals that are scaled to the quantized value except the inhibit code on the SDI standard as the SDI Full Range.</p>
EOTF Auto	<p>Select how to set EOTF when "Signal Format" is set to a setting other than "444 XYZ 12bit."</p> <ul style="list-style-type: none"> <li>• <b>On:</b> Use EOTF according to the input signal information. When the value of SDI Payload ID Transfer characteristics is Unspecified, EOTF that was set in "EOTF" is applied.</li> <li>• <b>Off:</b> Use EOTF that was set in "EOTF."</li> </ul>
EOTF	<p>Select the gamma from the following when "EOTF Auto" is set to "Off."</p> <ul style="list-style-type: none"> <li>• 2.2</li> <li>• 2.4</li> <li>• 2.6</li> <li>• CRT</li> <li>• 2.4(HDR)</li> <li>• S-Log3(HDR)</li> <li>• S-Log2(HDR)</li> <li>• SMPTE ST 2084(HDR)</li> <li>• ITU-R BT.2100(HLG)</li> <li>• S-Log3(Live HDR)</li> </ul> <p>When "ITU-R BT.2100(HLG)" is selected</p> <ul style="list-style-type: none"> <li>• <b>HLG System Gamma:</b> Sets the system gamma of the HLG. Set from 1.000 to 1.500. (Default value: 1.200)</li> </ul>
Col. Space/Mtx. Auto	<p>Select how to set the color space and transfer matrix when "Signal Format" is set to a setting other than "444 XYZ 12bit."</p> <ul style="list-style-type: none"> <li>• <b>On:</b> Use the color space and transfer matrix according to the input signal information.</li> <li>• <b>Off:</b> Use the color space and transfer matrix that was set in the menu.</li> </ul>

### Note

When "Signal Format" is set to "Auto" or "444 XYZ 12bit" and the XYZ signal is input, the optimum setting for the XYZ signal is fixed.

Submenu	Setting
Color Space	<p>Select the color space from the following when "Col. Space/Mtx. Auto" is set to "Off."</p> <ul style="list-style-type: none"> <li>• ITU-R BT.709</li> <li>• EBU</li> <li>• SMPTE-C</li> <li>• Native <sup>1)</sup></li> <li>• S-Gamut/S-Gamut3</li> <li>• S-Gamut3.Cine</li> <li>• DCI-P3</li> <li>• ITU-R BT.2020</li> </ul> <p>1) Displays with the unit's color space of the three primary color chromaticity points. This is the widest color space setting which the unit can reproduce.</p> <p><b>Note</b></p> <p>When "Signal Format" is set to "Auto" or "444 XYZ 12bit" and the XYZ signal is input, the optimum setting for the XYZ signal is fixed.</p>
Transfer Matrix	<p>Select the transfer matrix from the following when "Col. Space/Mtx. Auto" is set to "Off."</p> <ul style="list-style-type: none"> <li>• ITU-R BT.709</li> <li>• ITU-R BT.2020</li> </ul> <p>Set the following depending on the "Color Space" setting.</p> <p>When "ITU-R BT.2020" is selected: Select ITU-R BT.2020.</p> <p>When "ITU-R BT.709" is selected: Select ITU-R BT.709.</p> <p>When another item is selected: Select the transfer matrix setting of the device which outputs the signal.</p> <p><b>Note</b></p> <p>When "Signal Format" is set to "Auto" or "444 XYZ 12bit" and the XYZ signal is input, the optimum setting for the XYZ signal is fixed.</p>
User Preset	<p>Select the User Preset data to be applied.</p> <ul style="list-style-type: none"> <li>• User Preset1 (Default value)</li> <li>• User Preset2</li> <li>• User Preset3</li> <li>• User Preset4</li> <li>• User Preset5</li> <li>• User Preset XYZ</li> </ul> <p><b>Note</b></p> <p>When the XYZ format signal is input, set to "User Preset XYZ."</p>

Submenu	Setting
User LUT <sup>1)</sup>	<p>Select the User LUT file to apply to a picture.</p> <ul style="list-style-type: none"> <li>• Off (Default value)</li> <li>• User LUT1 to User LUT30</li> </ul> <p>When you select from "User LUT1" to "User LUT30"</p> <ul style="list-style-type: none"> <li>• <b>File Name:</b> Displays the User LUT name that you selected. Up to 15 characters of the User LUT name are displayed.</li> </ul> <p>When you press the SELECT/ENTER control after checking the file name, the selected file is applied to the picture.</p> <p><b>Note</b></p> <p>To apply the User LUT data, you need to load the User LUT file to the monitor in advance. For details, see "Loading User LUT files to the monitor" (page 36).</p> <p>1) Displayed only on the "SDI2 4K/UHD Input Setting" menu.</p>
Copy From	<p>Copy another input setting data to the selected input setting.</p> <ul style="list-style-type: none"> <li>• Input Setting1 (Default value)</li> <li>• Input Setting2</li> <li>• Input Setting3</li> <li>• Input Setting4</li> <li>• Input Setting5</li> <li>• Input Setting6</li> <li>• Input Setting7</li> <li>• Input Setting8</li> </ul>
Input Setting Skip	<p>Sets the skip setting when changing the input setting with Input select buttons (page 7) or the controller. Select "Skip"/"Not Skip" for each input setting of "Input Setting1" to "Input Setting8."</p> <ul style="list-style-type: none"> <li>• <b>Skip:</b> Skips.</li> <li>• <b>Not Skip:</b> Does not skip.</li> </ul> <p>When "Not Skip" is selected, the input setting changes in sequential order every time Input select buttons are pressed.</p>

### About S-Log3(Live HDR)

"S-Log3(Live HDR)" is the setting for which this unit is used as the reference monitor in the S-Log3 Live HDR workflow <sup>1)</sup> which Sony advocates. Displays the S-Log3 input signal adding the system gamma.

This system gamma is set so that the compatibility with the monitoring of the conventional (SDR) environment is valued and you can perform suitable picture expression without discomfort when adjusting the picture of the HDR camera.

1) Refer to the description of What's HDR and the Live HDR workflow on the Sony website.

## SDI1 2K/HD Input Setting / SDI2 2K/HD Input Setting

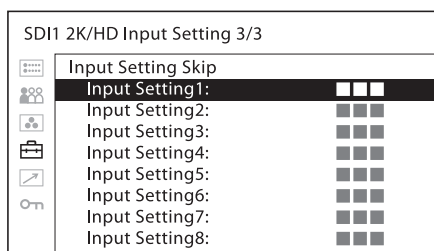
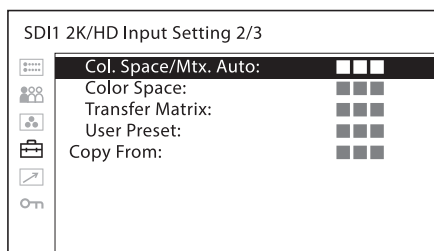
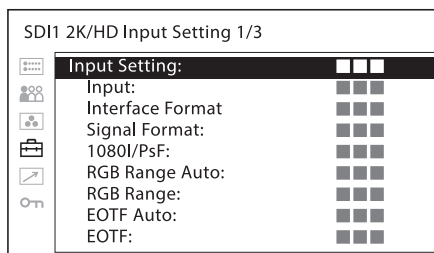

### Note

In the “SDI2 2K/HD Input Setting” menu, submenu items displayed on the “SDI2 2K/HD Input Setting 2/3” screen differ.

Submenu	Setting
Input Setting	<p>Sets the input setting of the SDI 2K signal. The input settings from “Input Setting1” to “Input Setting8” can be individually set for the SDI1 2K and SDI2 2K signals.</p> <ul style="list-style-type: none"> <li>• Input Setting1 (Default value)</li> <li>• Input Setting2</li> <li>• Input Setting3</li> <li>• Input Setting4</li> <li>• Input Setting5</li> <li>• Input Setting6</li> <li>• Input Setting7</li> <li>• Input Setting8</li> </ul>

Submenu	Setting
Input	<p>Set the input connector of the SDI 2K signal.</p> <ul style="list-style-type: none"> <li>• <b>Input1:</b> Select to use SDI IN [1] with Single Link.</li> <li>• <b>Input2:</b> Select to use SDI IN [2] with Single Link.</li> <li>• <b>Input3:</b> Select to use SDI IN [3] with Single Link.</li> <li>• <b>Input4:</b> Select to use SDI IN [4] with Single Link.</li> <li>• <b>Input1&amp;2:</b> Select to use SDI IN [1] and SDI IN [2] with Dual Link.</li> <li>• <b>Input3&amp;4:</b> Select to use SDI IN [3] and SDI IN [4] with Dual Link.</li> </ul>
Interface Format	<p>Displays the interface format of the SDI 2K signal.</p> <ul style="list-style-type: none"> <li>• <b>Single-Link 3G/HD-SDI:</b> For Single Link. (Default value)</li> <li>• <b>Dual-Link 3G/HD-SDI:</b> For Dual Link of 3G/HD-SDI.</li> </ul>
Signal Format	<p>Sets the signal format of the SDI 2K signal.</p> <ul style="list-style-type: none"> <li>• Auto (Default value)</li> <li>• 422 YCbCr 10bit</li> <li>• 444 RGB 10bit</li> <li>• 444 YCbCr 10bit</li> <li>• 444 RGB 12bit</li> <li>• 444 YCbCr 12bit</li> <li>• 444 XYZ 12bit</li> </ul>
1080I/PsF	<p>Set how to display when 50I, 59.94I, 60I, 25PsF, 29.97PsF, or 30PsF SDI 2K signals are input.</p> <p>23.98 Hz and 24 Hz signals are processed as the PsF signal.</p> <ul style="list-style-type: none"> <li>• <b>Auto:</b> When Payload ID is added to SDI signals, they are processed based on the ID data. They are processed as the interlace signals without the Payload ID. (Default value)</li> <li>• <b>PsF:</b> Processes as the PsF signal.</li> <li>• <b>Interlace:</b> Processes as the interlace signal.</li> </ul>
RGB Range Auto	<p>Select how to set the RGB Range.</p> <ul style="list-style-type: none"> <li>• <b>On:</b> Use the RGB Range according to the input signal information. (Default value)</li> <li>• <b>Off:</b> Use the RGB Range that was set in “RGB Range.”</li> </ul>
RGB Range	<p>Select from the following when “RGB Range Auto” is set to “Off” and the RGB signal is input.</p> <ul style="list-style-type: none"> <li>• <b>Full:</b> 0 to 1023 (10bit) / 0 to 4095 (12bit)</li> <li>• <b>Limited:</b> 64 to 940 (10bit) / 256 to 3760 (12bit) (Default value)</li> <li>• <b>SDI Full Range <sup>1)</sup>:</b> 4 to 1019 (10bit) / 16 to 4076 (12bit)</li> </ul>

1) This manual regards the Full Range signals that are scaled to the quantized value except the inhibit code on the SDI standard as the SDI Full Range.

Submenu	Setting
EOTF Auto	Select how to set EOTF when "Signal Format" is set to a setting other than "444 XYZ 12bit." <ul style="list-style-type: none"> <li>• <b>On:</b> Use EOTF according to the input signal information. When the value of SDI Payload ID Transfer characteristics is Unspecified, EOTF that was set in "EOTF" is applied. (Default value)</li> <li>• <b>Off:</b> Use EOTF that was set in "EOTF."</li> </ul>
EOTF	Select the gamma from the following when "EOTF Auto" is set to "Off." <ul style="list-style-type: none"> <li>• 2.2</li> <li>• 2.4 (Default value)</li> <li>• 2.6</li> <li>• CRT</li> <li>• 2.4(HDR)</li> <li>• S-Log3(HDR)</li> <li>• S-Log2(HDR)</li> <li>• SMPTE ST 2084(HDR)</li> <li>• ITU-R BT.2100(HLG)</li> <li>• S-Log3(Live HDR)</li> </ul> <p>When "ITU-R BT.2100(HLG)" is selected</p> <ul style="list-style-type: none"> <li>• <b>HLG System Gamma:</b> Sets the system gamma of the HLG. Set from 1.000 to 1.500. (Default value: 1.200)</li> </ul> <p><b>Note</b></p> <p>When "Signal Format" is set to "Auto" or "444 XYZ 12bit" and the XYZ signal is input, the optimum setting for the XYZ signal is fixed.</p>
Col. Space/Mtx. Auto	Select how to set the color space and transfer matrix when "Signal Format" is set to a setting other than "444 XYZ 12bit." <ul style="list-style-type: none"> <li>• <b>On:</b> Use the color space and transfer matrix according to the input signal information. (Default value)</li> <li>• <b>Off:</b> Use the color space and transfer matrix that was set in the menu.</li> </ul>

Submenu	Setting
Color Space	Select the color space from the following when "Col. Space/Mtx. Auto" is set to "Off." <ul style="list-style-type: none"> <li>• ITU-R BT.709 (Default value)</li> <li>• EBU</li> <li>• SMPTE-C</li> <li>• Native <sup>1)</sup></li> <li>• S-Gamut/S-Gamut3</li> <li>• S-Gamut3.Cine</li> <li>• DCI-P3</li> <li>• ITU-R BT.2020</li> </ul> <p>1) Displays with the unit's color space of the three primary color chromaticity points. This is the widest color space setting which the unit can reproduce.</p> <p><b>Note</b></p> <p>When "Signal Format" is set to "Auto" or "444 XYZ 12bit" and the XYZ signal is input, the optimum setting for the XYZ signal is fixed.</p>
Transfer Matrix	Select the transfer matrix from the following when "Col. Space/Mtx. Auto" is set to "Off." <ul style="list-style-type: none"> <li>• ITU-R BT.709 (Default value)</li> <li>• ITU-R BT.2020</li> </ul> <p>Set the following depending on the "Color Space" setting.</p> <p>When "ITU-R BT.2020" is selected: Select ITU-R BT.2020.</p> <p>When "ITU-R BT.709" is selected: Select ITU-R BT.709.</p> <p>When another item is selected: Select the transfer matrix setting of the device which outputs the signal.</p> <p><b>Note</b></p> <p>When "Signal Format" is set to "Auto" or "444 XYZ 12bit" and the XYZ signal is input, the optimum setting for the XYZ signal is fixed.</p>
User Preset	Select the User Preset data to be applied. <ul style="list-style-type: none"> <li>• User Preset1 (Default value)</li> <li>• User Preset2</li> <li>• User Preset3</li> <li>• User Preset4</li> <li>• User Preset5</li> <li>• User Preset XYZ</li> </ul> <p><b>Note</b></p> <p>When the XYZ format signal is input, set to "User Preset XYZ."</p>

Submenu	Setting
User LUT <sup>1)</sup>	<p>Select the User LUT file to apply to a picture.</p> <ul style="list-style-type: none"> <li>Off (Default value)</li> <li>User LUT1 to User LUT30</li> </ul> <p>When you select from "User LUT1" to "User LUT30"</p> <ul style="list-style-type: none"> <li><b>File Name:</b> Displays the User LUT name that you selected. Up to 15 characters of the User LUT name are displayed.</li> </ul> <p>When you press the SELECT/ENTER control after checking the file name, the selected file is applied to the picture.</p> <p><b>Note</b></p> <p>To apply the User LUT data, you need to load the User LUT file to the monitor in advance. For details, see "Loading User LUT files to the monitor" (page 36).</p> <p>1) Displayed only on the "SDI2 2K/HD Input Setting" menu.</p>
Copy From	<p>Copy another input setting data to the selected input setting.</p> <ul style="list-style-type: none"> <li>Input Setting1 (Default value)</li> <li>Input Setting2</li> <li>Input Setting3</li> <li>Input Setting4</li> <li>Input Setting5</li> <li>Input Setting6</li> <li>Input Setting7</li> <li>Input Setting8</li> </ul>
Input Setting Skip	<p>Sets the skip setting when changing the input setting with Input select buttons (page 7) or the controller. Select "Skip"/"Not Skip" for each input setting of "Input Setting1" to "Input Setting8."</p> <ul style="list-style-type: none"> <li><b>Skip:</b> Skips.</li> <li><b>Not Skip:</b> Does not skip.</li> </ul> <p>When "Not Skip" is selected, the input setting changes in sequential order every time Input select buttons are pressed.</p>

### Input Select

Sets the operation of the SDI2 4K/2K button.

- 4K:** Operates as the SDI2 4K button.
- 2K:** Operates as the SDI2 2K button.

## HDMI Input Setting (HDMI input only)

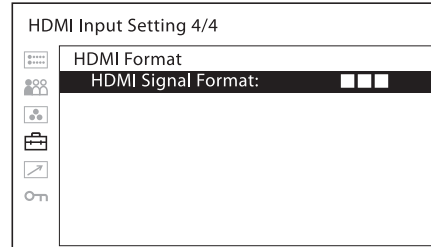
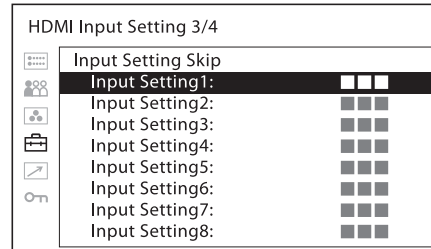
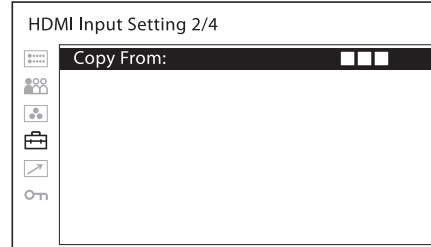
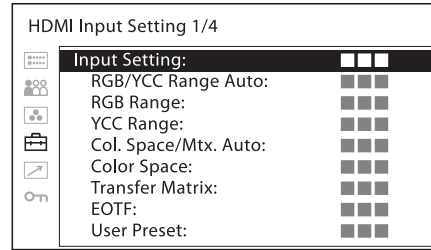

Submenu	Setting
Input Setting	<p>Sets the input setting of the HDMI signal.</p> <ul style="list-style-type: none"> <li>Input Setting1 (Default value)</li> <li>Input Setting2</li> <li>Input Setting3</li> <li>Input Setting4</li> <li>Input Setting5</li> <li>Input Setting6</li> <li>Input Setting7</li> <li>Input Setting8</li> </ul>
RGB/YCC Range Auto	<p>Select how to set the RGB/YCC Range.</p> <ul style="list-style-type: none"> <li><b>On:</b> Use the RGB/YCC Range according to the input signal information. (Default value)</li> <li><b>Off:</b> Use the RGB/YCC Range that was set in the menu.</li> </ul>

Submenu	Setting
RGB Range	When "RGB/YCC Range Auto" is set to "Off" and the signal is RGB, select from the following: <ul style="list-style-type: none"> <li>• <b>Full:</b> 0 to 1023 (10bit) / 0 to 4095 (12bit)</li> <li>• <b>Limited:</b> 64 to 940 (10bit) / 256 to 3760 (12bit)</li> </ul>
YCC Range	When "RGB/YCC Range Auto" is set to "Off" and the signal is YCbCr, select from the following: <ul style="list-style-type: none"> <li>• <b>Full:</b> 0 to 1023 (10bit) / 0 to 4095 (12bit)</li> <li>• <b>Limited:</b> 64 to 940 (10bit) / 256 to 3760 (12bit) (Default value)</li> </ul>
Col. Space/Mtx. Auto	Select how to set the color space and transfer matrix. <ul style="list-style-type: none"> <li>• <b>On:</b> Use the color space and transfer matrix according to the input signal information.</li> <li>• <b>Off:</b> Use the color space and transfer matrix that was set in the menu.</li> </ul>
Color Space	Select the color space from the following when "Col. Space/Mtx. Auto" is set to "Off." <ul style="list-style-type: none"> <li>• ITU-R BT.709</li> <li>• EBU</li> <li>• SMPTE-C</li> <li>• Native <sup>1)</sup></li> <li>• S-Gamut/S-Gamut3</li> <li>• S-Gamut3.Cine</li> <li>• DCI-P3</li> <li>• ITU-R BT.2020</li> </ul> <p>1) Displays with the unit's color space of the three primary color chromaticity points. This is the widest color space setting which the unit can reproduce.</p>
Transfer Matrix	Select the transfer matrix from the following when "Col. Space/Mtx. Auto" is set to "Off." <ul style="list-style-type: none"> <li>• ITU-R BT.709</li> <li>• ITU-R BT.2020</li> </ul> Set the following depending on the "Color Space" setting. When "ITU-R BT.2020" is selected: Select ITU-R BT.2020. When "ITU-R BT.709" is selected: Select ITU-R BT.709. When another item is selected: Select the transfer matrix setting of the device which outputs the signal.

Submenu	Setting
EOTF	Select the gamma from the following: <ul style="list-style-type: none"> <li>• 2.2</li> <li>• 2.4</li> <li>• 2.6</li> <li>• CRT</li> <li>• 2.4(HDR)</li> <li>• S-Log3(HDR)</li> <li>• S-Log2(HDR)</li> <li>• SMPTE ST 2084(HDR)</li> <li>• ITU-R BT.2100(HLG)</li> <li>• S-Log3(Live HDR)</li> </ul> <p>When "ITU-R BT.2100(HLG)" is selected</p> <ul style="list-style-type: none"> <li>• <b>HLG System Gamma:</b> Sets the system gamma of the HLG. Set from 1.000 to 1.500. (Default value: 1.200)</li> </ul>
User Preset	Select the User Preset data to be applied. <ul style="list-style-type: none"> <li>• User Preset1 (Default value)</li> <li>• User Preset2</li> <li>• User Preset3</li> <li>• User Preset4</li> <li>• User Preset5</li> <li>• User Preset XYZ</li> </ul>
<b>Note</b>	
When the XYZ format signal is input, set to "User Preset XYZ."	
Copy From	Copy another input setting data to the selected input setting. <ul style="list-style-type: none"> <li>• Input Setting1 (Default value)</li> <li>• Input Setting2</li> <li>• Input Setting3</li> <li>• Input Setting4</li> <li>• Input Setting5</li> <li>• Input Setting6</li> <li>• Input Setting7</li> <li>• Input Setting8</li> </ul>
Input Setting Skip	Sets the skip setting when changing the input setting with Input select buttons (page 7) or the controller. Select "Skip"/"Not Skip" for each input setting of "Input Setting1" to "Input Setting8." <ul style="list-style-type: none"> <li>• <b>Skip:</b> Skips.</li> <li>• <b>Not Skip:</b> Does not skip.</li> </ul> When "Not Skip" is selected, the input setting changes in sequential order every time Input select buttons are pressed.

Submenu	Setting
HDMI Format	
HDMI Signal Format	<p>Change the setting to receive images in a high-resolution HDMI signal <sup>1)</sup>.</p> <p>1) Signals in resolutions of 3840 × 2160 or 4096 × 2160 are listed below:</p> <p>4:4:4 RGB/YCbCr-50P/60P-8bit signals</p> <p>4:2:2 YCbCr-50P/60P-12bit signals</p> <p>4:4:4 RGB/YCbCr-24P/25P/30P-10/12bit signals</p> <ul style="list-style-type: none"> <li>• <b>Standard Format:</b> Select to use for a standard HDMI format signal. (Default value)</li> <li>• <b>Enhanced Format:</b> Select to use for a high-resolution HDMI format signal.</li> </ul>
	<p><b>Notes</b></p> <ul style="list-style-type: none"> <li>• Images and sounds may not be output correctly with "Enhanced Format." In that case, select "Standard Format."</li> <li>• To display the corresponding signal with "Enhanced Format," use a Premium High-Speed HDMI cable within a length of 3 meters (Sony product recommended).</li> </ul>

## Function Button Setting

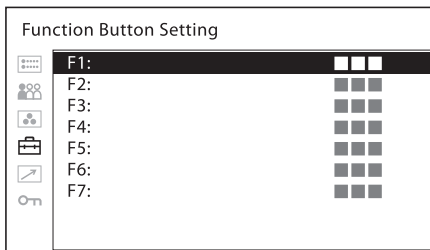

Submenu	Setting
F1 to F7	<p>Assigns functions to the function buttons of the front panel and turns the function on or off.</p> <p>The "Function Button Setting" menu can also be displayed by pressing and holding the function button, and the setting can be changed. Note that you cannot move to the other menu.</p>

## About functions that can be assigned to the function buttons on the unit and the buttons 1 to 9 on the controller

### Mono

Press the button to display a monochrome picture. When the button is pressed again, the monitor switches automatically to color mode.

### Blue Only

Press the button to eliminate the red and green signals. Only the blue signal is displayed as an apparent monochrome picture on the screen. This facilitates observation of signal noise.

### Native Scan

Press the button to switch between the image with the scaling display (Off) and the image displayed directly from pixels (On).

### Notes

- When Native Scan is selected, 2K resolution signals are displayed while enlarged horizontally and vertically with the following proportion (repeating pixel values).
  - 1280 × 720 signal: × 3
  - Others: × 2
- 640 × 480/60P, 720 × 480/60P, and 720 × 576/50P signals for HDMI are not enlarged up to the end of the display.

### Audio Muting

Press to turn off the sound from the headphone output. To turn on the sound, press this once again or turn the volume up adjusting "Volume" of the "User Preset Setting menu" (page 19).

### R Off

Press the button to turn off the R (red) signal.

### G Off

Press the button to turn off the G (green) signal.

### B Off

Press the button to turn off the B (blue) signal.

### Character Off

Press the button to hide the menu while adjusting the picture. When the button is pressed again, the monitor switches to the previous display.

### Internal Signal

Press the button to display the internal signal.

### Internal Signal Pattern

Press the button to change the pattern of the internal signal when the internal signal is displayed. With every press of the button, the picture switches to "PLUGE," "Gray," "White," "5 Step," "Ramp," and "Color Bars," in this order.

### Interlace

Press the button to display with the interlace.

### **Gamut Marker**

Press the button to display the gamut marker.

### **Input Setting1**

### **Input Setting2**

### **Input Setting3**

### **Input Setting4**

### **Input Setting5**

### **Input Setting6**

### **Input Setting7**

### **Input Setting8**

Press the button so that the setting switches to the assigned input setting.

### **Marker**

Press the button to display the aspect marker, area marker 1, area marker 2 or center marker with the selected marker preset setting.

### **Aspect Marker**

Press the button to display the aspect marker.

### **Area Marker1**

Press the button to display area marker 1.

### **Area Marker2**

Press the button to display area marker 2.

### **Center Marker**

Press the button to display the center marker.

### **Aspect Marker-Line**

Press the button to display the line of the aspect marker.

### **Aspect Blanking-Half**

Press the button to set the aspect blanking to half.

### **Aspect Blanking-Black**

Press the button to set the aspect blanking to black.

### **Note**

The "Marker" to "Aspect Blanking-Black" settings are not available in the following cases:

- When the input signal is no sync signal
- When the internal signal is displayed
- When the screen saver is activated

### **Time Code**

Press the button to display the "Time Code." Adjust the settings for the "Time Code" in "Time Code Setting" (page 34).

### **Relative Contrast 1/2**

Press the button to reduce the contrast (including the contrast setting value that was set manually) of the screen to 1/2 during the HDR display.

### **Relative Contrast 1/3**

Press the button to reduce the contrast (including the contrast setting value that was set manually) of the screen to 1/3 during the HDR display.

### **Relative Contrast 1/4**

Press the button to reduce the contrast (including the contrast setting value that was set manually) of the screen to 1/4 during the HDR display.

### **SDI1 4K 1)**

Press the button to monitor the 4K signal through the SDI 1 IN connector (operates in the same way as the SDI1 4K button on the front panel).

### **SDI1 2K 1)**

Press the button to monitor the 2K signal through the SDI 1 IN connector (operates in the same way as the SDI1 2K button on the front panel).

### **SDI2 4K 1)**

Press the button to monitor the 4K signal through the SDI 2 IN connector (operates in the same way as the SDI2 4K/2K button on the front panel while "Input Select" of SDI2 is set to "4K").

### **SDI2 2K 1)**

Press the button to monitor the 2K signal through the SDI 2 IN connector (operates in the same way as the SDI2 4K/2K button on the front panel while "Input Select" of SDI2 is set to "2K").

### **HDMI 1)**

Press the button to monitor the signal through the HDMI connector.

### **Quad View**

Press the button to display four inputs on the screen. Press again to return to the previous screen.

- 1) You cannot assign this function to the function buttons on the unit. It can only be assigned to the buttons 1 to 9 on the controller.

## Audio Setting

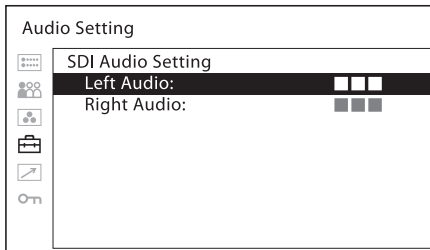

Submenu	Setting
SDI Audio Setting	<p>Sets the audio channel when SDI signal is input.</p> <ul style="list-style-type: none"> <li>• <b>Left Audio:</b> Select from channels "CH1" to "CH16." (Default value: CH1)</li> <li>• <b>Right Audio:</b> Select from channels "CH1" to "CH16." (Default value: CH2)</li> </ul> <p>When a channel from "CH1" to "CH8" is selected in "Left Audio," you cannot select a channel other than a channel from "CH1" to "CH8" (e.g.: CH9) in "Right Audio."</p> <p>When a channel from "CH9" to "CH16" is selected in "Left Audio," you cannot select a channel other than a channel from "CH9" to "CH16" (e.g.: CH1) in "Right Audio."</p>

## Internal Signal Setting

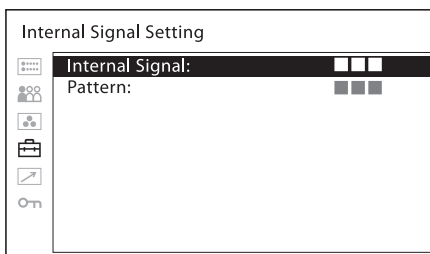

Submenu	Setting
Internal Signal	<p>Turns the internal signal display On/Off.</p> <ul style="list-style-type: none"> <li>• <b>On:</b> The internal signal is displayed.</li> <li>• <b>Off:</b> The internal signal is not displayed. (Default value)</li> </ul>
Pattern	<p>Select the pattern of the internal signal.</p> <ul style="list-style-type: none"> <li>• PLUGE</li> <li>• Gray</li> <li>• White (Default value)</li> <li>• 5 Step</li> <li>• Ramp</li> <li>• Color Bars</li> </ul>

## Gamut Marker Setting

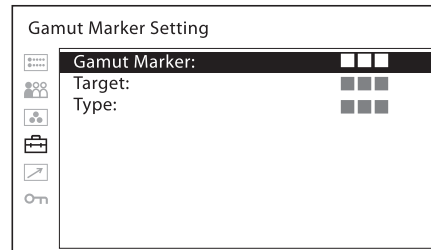

Submenu	Setting
Gamut Marker	<p>Turns the gamut marker On/Off. The zebra pattern can be displayed for the signal outside of the targeted color space while "ITU-R BT.2020" is selected for "Color Space."</p> <ul style="list-style-type: none"> <li>• <b>On:</b> Displays the gamut marker.</li> <li>• <b>Off:</b> Disables the gamut marker function. (Default value)</li> </ul>
Target	<p>Sets the targeted color space. The zebra pattern can be displayed for the signal outside of the selected color space. 1)</p> <ul style="list-style-type: none"> <li>• ITU-R BT.709 (Default value)</li> <li>• DCI-P3</li> </ul> <p><b>Notes</b></p> <ul style="list-style-type: none"> <li>• The setting is available while "ITU-R BT.2020" is selected for "Color Space."</li> <li>• The setting does not depend on the status of picture control functions such as contrast, chroma or white balance.</li> <li>• When the input signal which is included the noise composition is over the targeted color space, the zebra pattern display may emphasize the noise.</li> </ul>
Type	<ul style="list-style-type: none"> <li>• <b>Type1:</b> Displays the black zebra pattern. (Default value)</li> <li>• <b>Type2:</b> Displays the black &amp; white zebra pattern.</li> </ul>

1) For detecting the color space, use the following definitions of the transmission gamma based on the selected EOTF.

The EOTF's selection on the unit	The definitions used while detecting the color space
2.2, 2.4, 2.6, CRT, 2.4(HDR)	ITU-R BT.2020
S-Log3(HDR), S-Log3(Live HDR)	sLog3
S-Log2(HDR)	sLog2
SMPTE ST 2084(HDR)	SMPTE ST 2084
ITU-R BT.2100(HLG)	ITU-R BT.2100

## Area and Aspect Marker Setting

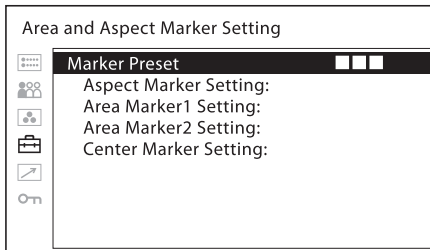

### Marker Preset

Displays the selected marker preset data. (Default value: Marker Preset1)

### Aspect Marker Setting

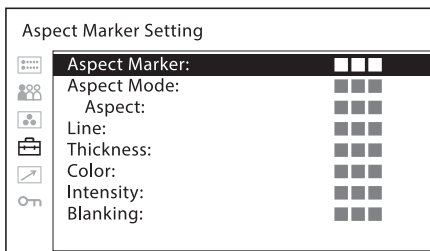

Submenu	Setting
Aspect Marker	Sets whether or not to display the aspect marker (Off or On). (Default value: Off)
Aspect Mode	Sets the aspect ratio of the aspect marker. <ul style="list-style-type: none"> <li>16:9 (Default value)</li> <li>15:9</li> <li>14:9</li> <li>13:9</li> <li>4:3</li> <li>2.39:1</li> <li>2.35:1</li> <li>1.85:1</li> <li>1.66:1</li> <li>1.896:1</li> <li>Variable</li> </ul>
Aspect	Sets the aspect ratio of the aspect marker when "Variable" is selected in "Aspect Mode." Set to 1.00:1 to 3.00:1. (Default value: 1.78:1)
Line	Sets whether or not to display the line of the aspect marker (Off or On). (Default value: On)
Thickness	Sets the thickness of the line of the aspect marker. <ul style="list-style-type: none"> <li>1 dot</li> <li>2 dots (Default value)</li> <li>3 dots</li> <li>4 dots</li> <li>5 dots</li> </ul>

Submenu	Setting
Color	Sets the color of the aspect marker. <ul style="list-style-type: none"> <li>White (white) (Default value)</li> <li>Red (red)</li> <li>Green (green)</li> <li>Blue (blue)</li> <li>Yellow (yellow)</li> <li>Cyan (cyan)</li> <li>Magenta (magenta)</li> </ul>
Intensity	Sets the luminance of the aspect marker. <ul style="list-style-type: none"> <li>High (bright)</li> <li>Low (dark) (Default value)</li> </ul>
Blanking	Sets the blanking outside the area of the aspect marker. <ul style="list-style-type: none"> <li><b>Off:</b> Blanking is released. (Default value)</li> <li><b>Black:</b> Sets blanking.</li> <li><b>Half:</b> Sets half blanking.</li> </ul>

### Area Marker1 Setting

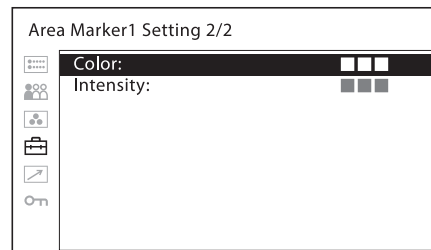
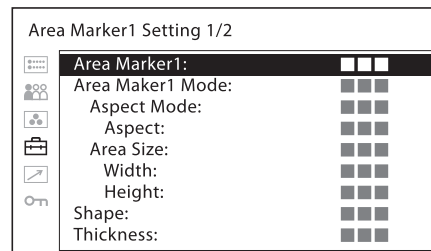

Submenu	Setting
Area Marker1	Sets whether or not to display area marker 1 (Off or On).
Area Marker1 Mode	Sets the display mode of the area marker. <ul style="list-style-type: none"> <li>Safe Area Marker (Default value)</li> <li>Flexible Area Marker</li> </ul>

Submenu	Setting
Aspect Mode	<p>Sets the aspect ratio of area marker 1 when "Safe Area Marker" is selected in "Area Marker1 Mode."</p> <ul style="list-style-type: none"> <li>• 16:9 (Default value)</li> <li>• 15:9</li> <li>• 14:9</li> <li>• 13:9</li> <li>• 4:3</li> <li>• 2.39:1</li> <li>• 2.35:1</li> <li>• 1.85:1</li> <li>• 1.66:1</li> <li>• 1.896:1</li> <li>• Variable</li> </ul>

**Note**

When "Variable(dots)" is selected in "Area Size," the size of area marker 1 is set in the pixels of the input signal and the "Aspect Mode" setting becomes invalid.

When "Variable" is selected in "Aspect Mode"

- **Aspect:** Sets the aspect ratio of area marker 1. Set to 1.00:1 to 3.00:1. (Default value: 1.78:1)

Area Size	<p>Sets the size of area marker 1 when "Safe Area Marker" is selected in "Area Marker1 Mode."</p> <ul style="list-style-type: none"> <li>• 80% (Default value)</li> <li>• 88%</li> <li>• 90%</li> <li>• 93%</li> <li>• Variable(%)</li> <li>• Variable(dots)</li> </ul>
-----------	-------------------------------------------------------------------------------------------------------------------------------------------------------------------------------------------------------------------------------------------------------------------------

When "Area Size" is set to "Variable(%)" or "Variable(dots)"

- **Width:** Sets the width of area marker 1.
  - Set to 050 to 100 (%) when "Variable(%)" is selected. (Default value: 080 %)
  - Set to 640 to 4096 (dots) when "Variable(dots)" is selected. Set one digit each. (Default value: 1024 dots)
- **Height:** Sets the height of area marker 1.
  - Set to 050 to 100 (%) when "Variable(%)" is selected. (Default value: 080 %)
  - Set to 360 to 2160 (dots) when "Variable(dots)" is selected. Set one digit each. (Default value: 0576 dots)

H Position	<p>Sets the horizontal position of the marker at the top left corner of the image display area as the starting point when "Flexible Area Marker" is selected in "Area Marker1 Mode." You can set to a position from 0 to 4095.</p>
------------	------------------------------------------------------------------------------------------------------------------------------------------------------------------------------------------------------------------------------------

Submenu	Setting
V Position	<p>Sets the vertical position of the marker at the top left corner of the image display area as the starting point when "Flexible Area Marker" is selected in "Area Marker1 Mode." You can set to a position from 0 to 2159. (Default value: 200)</p>
Width	<p>Sets the width of the marker when "Flexible Area Marker" is selected in "Area Marker1 Mode." You can set to a position from 1 to 4096.</p>
Height	<p>Sets the height of the marker when "Flexible Area Marker" is selected in "Area Marker1 Mode." You can set to a position from 1 to 2160. (Default value: 1760)</p>

Shape	<p>Sets the shape of area marker 1.</p> <ul style="list-style-type: none"> <li>• <b>Shape A</b> (Default value)</li> </ul>
-------	----------------------------------------------------------------------------------------------------------------------------



- **Shape B**



- **Shape C**

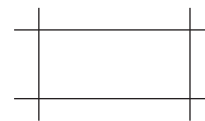

**Note**

When "Safe Area Marker" is selected in "Area Marker1 Mode," the size of the area differs depending on the "Aspect Mode" setting.

With 1.896:1

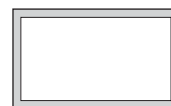

80% Aspect Mode is set to 1.896:1



80% Aspect Mode is set to 4:3

With 4:3



80% Aspect Mode is set to 1.896:1



80% Aspect Mode is set to 4:3

Submenu	Setting
Thickness	Sets the thickness of the line of the area marker 1. <ul style="list-style-type: none"> <li>• 1 dot</li> <li>• 2 dots (Default value)</li> <li>• 3 dots</li> <li>• 4 dots</li> <li>• 5 dots</li> </ul>
Color	Sets the color of area marker 1. <ul style="list-style-type: none"> <li>• White (white) (Default value)</li> <li>• Red (red)</li> <li>• Green (green)</li> <li>• Blue (blue)</li> <li>• Yellow (yellow)</li> <li>• Cyan (cyan)</li> <li>• Magenta (magenta)</li> </ul>
Intensity	Sets the luminance of area marker 1. <ul style="list-style-type: none"> <li>• High (bright)</li> <li>• Low (dark) (Default value)</li> </ul>



### Area Marker2 Setting

Sets area marker 2. The set items are the same as for "Area Marker1 Setting."

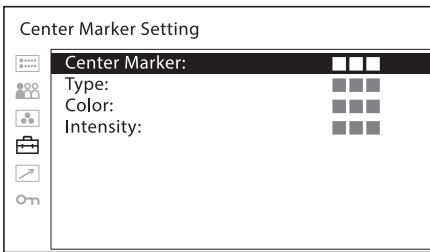
### Center Marker Setting

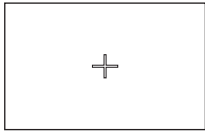

Submenu	Setting
Center Marker	Sets whether or not to display the center marker (Off or On). (Default value: Off)

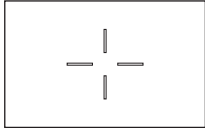
Submenu	Setting
Type	Sets the display mode of the center marker. <ul style="list-style-type: none"> <li>• <b>Type1</b> (Default value)</li> </ul>  <ul style="list-style-type: none"> <li>• <b>Type2</b></li> </ul>  <ul style="list-style-type: none"> <li>• <b>Type3</b></li> </ul> 

Color	Sets the color of the center marker. <ul style="list-style-type: none"> <li>• White (white) (Default value)</li> <li>• Red (red)</li> <li>• Green (green)</li> <li>• Blue (blue)</li> <li>• Yellow (yellow)</li> <li>• Cyan (cyan)</li> <li>• Magenta (magenta)</li> </ul>
Intensity	Sets the luminance of the center marker. <ul style="list-style-type: none"> <li>• High (bright)</li> <li>• Low (dark) (Default value)</li> </ul>

### Time Code Setting

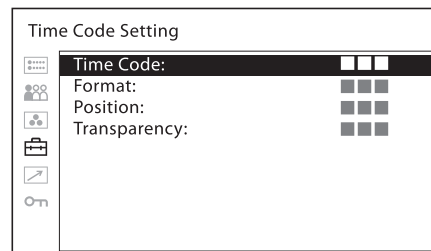

Submenu	Setting
Time Code	Turns the time code display On/Off. <ul style="list-style-type: none"> <li>• <b>On:</b> The time code is displayed.</li> <li>• <b>Off:</b> The time code is not displayed. (Default value)</li> </ul>
Format	Sets the time code format. <ul style="list-style-type: none"> <li>• <b>VITC:</b> To display the time code in VITC format. (Default value)</li> <li>• <b>LTC:</b> To display the time code in LTC format.</li> </ul>

Submenu	Setting
Position	Sets the position of the time code display. <ul style="list-style-type: none"> <li>• Top (Default value)</li> <li>• Bottom</li> </ul>
Transparency	Sets the background transparency of the time code display. <ul style="list-style-type: none"> <li>• <b>Black:</b> The background becomes black.</li> <li>• <b>Half:</b> The background becomes translucent. (Default value)</li> </ul>

## Quad View Setting

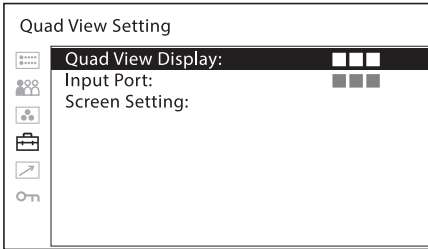

Submenu	Setting
Quad View Display	Sets the Quad View On or Off. <ul style="list-style-type: none"> <li>• <b>On:</b> Displays in Quad View.</li> <li>• <b>Off:</b> Turns off the Quad View function. (Default value)</li> </ul>
Input Port	Select the input signal for Quad View. <ul style="list-style-type: none"> <li>• <b>SDI1/HDMI:</b> Displays the 2K/HD signal input from the SDI 1 IN connector and HDMI IN connector. (Default value)</li> <li>• <b>SDI2/HDMI:</b> Displays the 2K/HD signal input from the SDI 2 IN connector and HDMI IN connector.</li> </ul>

## Screen Setting

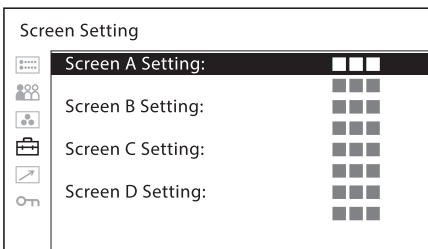

Submenu	Setting
Screen A Setting to Screen D Setting	Select the Input Setting. <ul style="list-style-type: none"> <li>• SDI 2K/HD In. Setting1</li> <li>• SDI 2K/HD In. Setting2</li> <li>• SDI 2K/HD In. Setting3</li> <li>• SDI 2K/HD In. Setting4</li> <li>• SDI 2K/HD In. Setting5</li> <li>• SDI 2K/HD In. Setting6</li> <li>• SDI 2K/HD In. Setting7</li> <li>• SDI 2K/HD In. Setting8</li> <li>• HDMI Input Setting1</li> <li>• HDMI Input Setting2</li> <li>• HDMI Input Setting3</li> <li>• HDMI Input Setting4</li> <li>• HDMI Input Setting5</li> <li>• HDMI Input Setting6</li> <li>• HDMI Input Setting7</li> <li>• HDMI Input Setting8</li> </ul>

## About the Quad View setting

When Quad View is set to "On," the screen is divided into four parts.

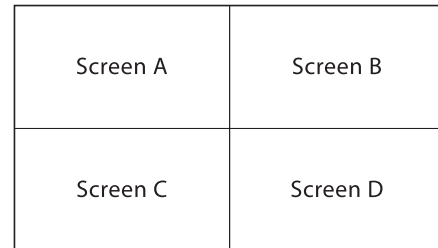

### Notes

- The signal equivalent to HDMI/SDI 4K cannot be displayed with Quad View.
- Only one Input Setting per input terminal can be displayed simultaneously. Example: If "Input Setting1" and "Input Setting2" is set to the same SDI1 input connector 1, they cannot be displayed at same time. To compare the same image, input the image of input connector 1 to the other connector and set "Input Setting2" to the input connector. When a combination which cannot be displayed simultaneously is set, the screen which can be displayed is displayed in order from Screen A. If the screen cannot be displayed, it turns black and the "Invalid Input Combination" message is displayed.
- Time code is displayed on only the signal that is input to Screen A.
- The audio signal input on Screen A is output.
- The drive frequency of the panel changes to the same as Screen A.

- The combination of SDI 1 and SDI2 cannot be displayed with Quad View.
- “Native Scan” is set to “Off.”
- The XYZ format signal is not supported.
- Set the same “RGB/YCC Range” settings for the all screens.
- Sets the same frame rate of the signal which is input to each screen for all screens.
- Set “Gamut Marker” and “Mono” to “Off.”

The following settings are available with a combination of Input Setting and User Preset.

Screen A SDI1 INPUT1, HDR (D65, BT.2020, S-Log3)	Screen B HDMI, SDR (D65, BT709, 2.4)
Screen C SDI1 INPUT3, SDR (D65, BT.2020, 2.4)	Screen D SDI1 INPUT4, HDR (D65, BT.2020, ST 2084)

## User LUT Setting

3D LUT files (Cube files), that are created with the RAW Viewer application or color grading tool, can be saved in the USB memory and loaded via the controller BKM-17R.

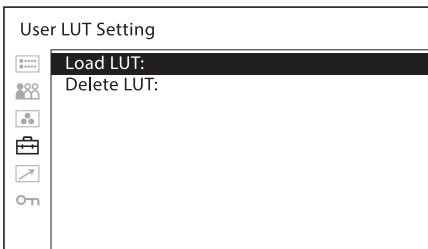

Submenu	Setting
Load LUT	Loads 3D LUT files to the monitor. Up to 30 files from “User LUT1” to “User LUT30” can be loaded.
Delete LUT	Individually or collectively deletes the 3D LUT files which were loaded to the monitor.

## Loading User LUT files to the monitor

User LUT files are loaded to the monitor via the controller BKM-17R.

To apply the loaded User LUT files to the input signals, you need to set “User LUT” (page 24, 27) in the “Input Setting” menu.

### Note

Connect the monitor and controller with the Peer to Peer connection.

- 1 Save the desired User LUT files to the following folder in the USB memory.

MSSONY/MONITOR/BVM/USER\_LUT

### Notes

- The USB memory is only FAT32 format-compatible.
- Cube files with the following conditions can be loaded.  
File format: Adobe .cube  
Number of lattice points: 17 or 33
- The loading 3D LUT file should be named up to a total of 20 alphanumeric characters (one-byte characters) including “-” and “\_” (excluding extension).
- Up to 15 characters of the 3D LUT file name are displayed in the menu of the monitor.
- Up to 1,000 User LUT files can be saved in the USB memory.

- 2 Connect the USB memory with the User LUT files saved to the USB connector on the controller BKM-17R.

- 3 Select “Load LUT” in the “User LUT Setting” menu, then select the desired User LUT number to load the User LUT file.

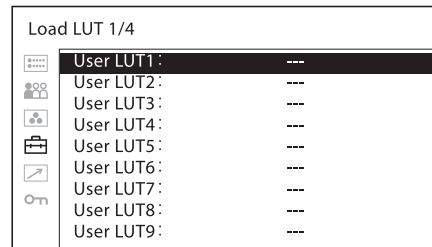

Files are loaded from the USB memory. “In Progress” is displayed while loading the files and LEDs on the function buttons light in order from F1 to F7.

When loading has completed, the User LUT files saved in the USB memory are listed on the screen of the selected User LUT number.

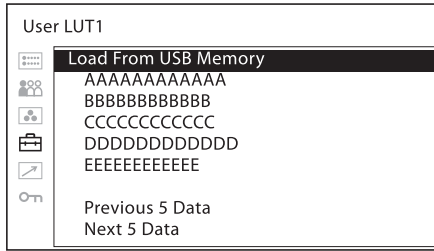

The files are displayed in numerical and alphabetical order. When more than 6 files are saved, selecting the “Previous 5 Data” or “Next 5 Data” displays other files.

- 4 Select the desired User LUT file.
- 5 Select “Confirm” on the “Load From USB Memory” screen.

The User LUT file is loaded from the USB memory to the monitor. “In Progress” is displayed while loading the file and LEDs on the function buttons light in order from F1 to F7.

When loading has completed, the User LUT file name is displayed next to the selected User LUT number.

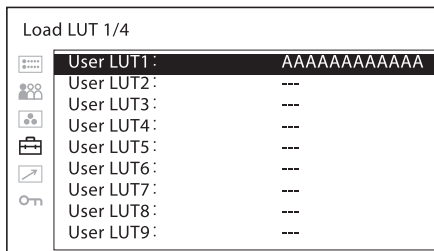

**Note**

If the User LUT file is not compatible with the file format that can be loaded to the monitor, the file name is not displayed next to the selected User LUT number and the loading terminates.

**Serial Remote menu**

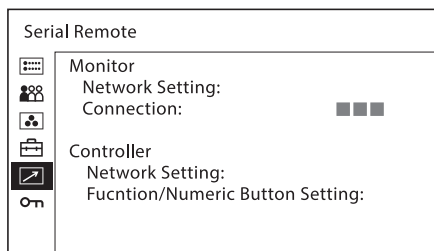

Submenu	Setting
Monitor	Sets the monitor setting.
Network Setting	<ul style="list-style-type: none"> <li>• <b>Monitor ID:</b> Sets the ID of the monitor. (Default value: 1)</li> <li>• <b>Group ID:</b> Sets the group ID of the monitor. (Default value: 1)</li> <li>• <b>IP Address:</b> Sets the IP address. (Default value: 192.168.000.001)</li> <li>• <b>Subnet Mask:</b> Sets the subnet mask. (Default value: 255.255.255.000)</li> <li>• <b>Default Gateway:</b> Sets the default gateway On or Off. (Default value: Off)</li> <li>• <b>Address:</b> Sets the default gateway. (Default value: 000.000.000.000)</li> <li>• <b>Cancel:</b> Selects to cancel the setting.</li> <li>• <b>Confirm:</b> Selects to save the setting.</li> </ul>
Connection	Sets the connection of the monitor and the controller. <ul style="list-style-type: none"> <li>• <b>Peer to Peer:</b> for one to one connection</li> <li>• <b>LAN:</b> for connection via a network</li> </ul>
Controller	Sets the controller setting.
Network Setting	<ul style="list-style-type: none"> <li>• <b>IP Address:</b> Sets the IP address.</li> <li>• <b>Subnet Mask:</b> Sets the subnet mask.</li> <li>• <b>Default Gateway:</b> Sets the default gateway On or Off.</li> <li>• <b>Address:</b> Sets the default gateway.</li> <li>• <b>Cancel:</b> Selects to cancel the setting.</li> <li>• <b>Confirm:</b> Selects to save the setting.</li> </ul>
Function/Numeric Button Setting	Set functions to be assigned to the F1 to F16 buttons and 1 to 9 buttons on the controller. For available functions with this unit, see page 9. For the functions which are assigned to the 1 to 9 buttons, see “About functions that can be assigned to the function buttons on the unit and the buttons 1 to 9 on the controller” (page 29).

**Note**

The “Controller” menu is available when the menu is displayed via the controller. (Only when the controller is connected with the Peer to Peer connection or Single connection.)

**Security menu**

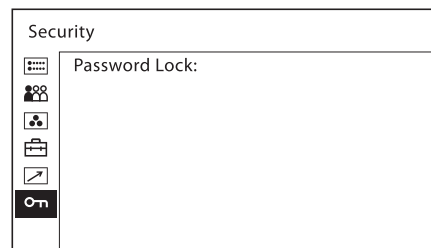

Submenu	Setting
Password Lock	<p>You can protect the setting with a password so that the settings saved in the color temperature for "User1" and the User Preset for "User Preset1" cannot be changed.</p> <p>When you protect the values with a password, set a four-digit number. The initial password is "0000." When you use "Password Lock," change the initial password first.</p> <ul style="list-style-type: none"> <li>• <b>Color Temp./User Pre.:</b> Select "On" to protect the setting values saved in the color temperature for "User1" and the User Preset for "User Preset1." Select "Off" to not protect with the password. (Default value: Off)</li> <li>• <b>Change Password:</b> Changes the password.</li> </ul>
	<p><b>Note</b></p> <p>If you forget the password, refer to Sony qualified service personnel.</p>

## Troubleshooting

This section may help you isolate the cause of a problem and as a result, eliminate the need to contact technical support.

- **The unit cannot be operated** → The key protection function is on. Press and hold the KEY INHIBIT button (page 7) for more than two seconds to set the protection of the setting value to off.  
Or, a function that does not work is assigned to a function button. When the menu is not displayed, press the SELECT/ENTER control (page 8) to confirm the functions assigned to function buttons.
- **Adjustments and settings cannot be made** → Adjustments and settings may not be possible depending on the input signals and the status of the unit. See "Input Signals and Adjustable/Setting Items" (page 10).
- **The black bars appear at the upper and lower or left and right positions of the display** → When the signal aspect ratio is different from that of the panel, the black bars appear. This is not a failure of the unit.
- **The screen becomes dark and the unit turns off** → If the internal temperature of the unit increases, the screen may become dark and the unit may turn off.  
Check if the ventilation slots or vents are blocked with something such as dust. In this case, refer to Sony qualified service personnel.
- **Color is not displayed correctly** → Check the "Interface Format" display (page 23, page 25) or the "Signal Format" (page 23, page 25), "Color Temp." (page 20), or "Color Space" (page 24, page 26, page 28) setting.

# Specifications

## Picture performance

LCD panel	a-Si TFT Active Matrix
Picture size (diagonal)	789.1 mm (31.1 inches)
Effective picture size (H × V)	698.0 × 368.1 mm (27 1/2 × 14 1/2 inches)
Resolution (H × V)	4096 × 2160 pixels
Aspect	17:9
Pixel efficiency	99.99%
Panel drive	RGB 10-bit
Viewing angle (Panel specification)	89°/89°/89°/89° (typical) (up/down/left/right, contrast > 10:1)
Scan	0% scan (fixed)
Color temperature	D65, D93, D61, D55, DCI
Standard luminance (SDR 100% white signal input)	100 cd/m <sup>2</sup> (User Preset1 – User Preset5) 48 cd/m <sup>2</sup> (User Preset XYZ)
Warm-up time	Approx. 30 minutes To provide stable picture quality, turn on the power of the monitor and leave it in this state for more than 30 minutes.

## Input

SDI 1 (3G/HD) input	BNC type (4) Input impedance: 75 Ω unbalanced
SDI 2 (3G/HD) input	BNC type (2) Input impedance: 75 Ω unbalanced
SDI 2 (12G/6G/3G/HD) input	BNC type (2) Input impedance: 75 Ω unbalanced
HDMI input	HDMI connector (1) HDCP 2.3
Serial remote (LAN)	RJ-45 modular connector (1) Ethernet (10BASE-T/100BASE-TX)

## Output

MONITOR (3G/HD) output	BNC type (4) Output impedance: 75 Ω unbalanced
SDI 2 (3G/HD) output	BNC type (2) Output impedance: 75 Ω unbalanced
SDI 2 (12G/6G/3G/HD) output	BNC type (2) Output impedance: 75 Ω unbalanced
Audio monitor output connector	Stereo mini jack (1)
Headphones output connector	Stereo mini jack (1)

## General

Power	AC 100 V to 240 V, 5.1 A to 2.1 A, 50/60 Hz
Power consumption	Approx. 450 W (max.)
Operating conditions	Temperature 0 °C to 35 °C (32 °F to 95 °F) Recommended temperature 20 °C to 30 °C (68 °F to 86 °F) Humidity 30% to 85% (no condensation) Pressure 700 hPa to 1060 hPa
Storage and transport conditions	Temperature –20 °C to +60 °C (–4 °F to +140 °F) Humidity 0% to 90% Pressure 700 hPa to 1060 hPa
Accessories supplied	AC power cord (1) AC plug holder (1) Before Using This Unit (1) CD-ROM (1)

Design and specifications are subject to change without notice.

## Available Signal Formats

The unit is applicable to the following signal formats.

### 2K/HD (HD-SDI)

Signal System	Signal Structure	SDI 1	SDI 2
1920 × 1080/60I <sup>1)</sup>	4 : 2 : 2 (YCbCr) 10bit	○	○
1920 × 1080/50I	4 : 2 : 2 (YCbCr) 10bit	○	○
1920 × 1080/30P <sup>1)</sup>	4 : 2 : 2 (YCbCr) 10bit	○	○
1920 × 1080/30PsF <sup>1)</sup>	4 : 2 : 2 (YCbCr) 10bit	○	○
1920 × 1080/25P	4 : 2 : 2 (YCbCr) 10bit	○	○
1920 × 1080/25PsF	4 : 2 : 2 (YCbCr) 10bit	○	○
1920 × 1080/24P <sup>1)</sup>	4 : 2 : 2 (YCbCr) 10bit	○	○
1920 × 1080/24PsF <sup>1)</sup>	4 : 2 : 2 (YCbCr) 10bit	○	○
1280 × 720/60P <sup>1)</sup>	4 : 2 : 2 (YCbCr) 10bit	○	○
1280 × 720/50P	4 : 2 : 2 (YCbCr) 10bit	○	○
1280 × 720/30P <sup>1)</sup>	4 : 2 : 2 (YCbCr) 10bit	○	○
1280 × 720/25P	4 : 2 : 2 (YCbCr) 10bit	○	○
1280 × 720/24P <sup>1)</sup>	4 : 2 : 2 (YCbCr) 10bit	○	○
2048 × 1080/30P <sup>1)</sup>	4 : 2 : 2 (YCbCr) 10bit	○	○
2048 × 1080/30PsF <sup>1)</sup>	4 : 2 : 2 (YCbCr) 10bit	○	○
2048 × 1080/25P	4 : 2 : 2 (YCbCr) 10bit	○	○
2048 × 1080/25PsF	4 : 2 : 2 (YCbCr) 10bit	○	○
2048 × 1080/24P <sup>1)</sup>	4 : 2 : 2 (YCbCr) 10bit	○	○
2048 × 1080/24PsF <sup>1)</sup>	4 : 2 : 2 (YCbCr) 10bit	○	○

### 2K/HD (HD-SDI Dual Link)

Signal System	Signal Structure	SDI 1	SDI 2
1920 × 1080/60P <sup>1)</sup>	4 : 2 : 2 (YCbCr) 10bit	○	○
1920 × 1080/50P	4 : 2 : 2 (YCbCr) 10bit	○	○
1920 × 1080/60I <sup>1)</sup>	4 : 4 : 4 (RGB) 10bit	○	○
	4 : 4 : 4 (YCbCr) 10bit		
	4 : 4 : 4 (RGB) 12bit		
1920 × 1080/50I	4 : 4 : 4 (YCbCr) 12bit	○	○
	4 : 4 : 4 (RGB) 10bit		
	4 : 4 : 4 (RGB) 12bit		
1920 × 1080/30P <sup>1)</sup>	4 : 4 : 4 (YCbCr) 10bit	○	○
	4 : 4 : 4 (RGB) 12bit		
	4 : 4 : 4 (YCbCr) 12bit		
1920 × 1080/30PsF <sup>1)</sup>	4 : 4 : 4 (RGB) 10bit	○	○
	4 : 4 : 4 (YCbCr) 10bit		
	4 : 4 : 4 (RGB) 12bit		

Signal System	Signal Structure	SDI 1	SDI 2
1920 × 1080/25P	4 : 4 : 4 (RGB) 10bit	○	○
	4 : 4 : 4 (YCbCr) 10bit		
	4 : 4 : 4 (RGB) 12bit		
	4 : 4 : 4 (YCbCr) 12bit		
1920 × 1080/25PsF	4 : 4 : 4 (RGB) 10bit	○	○
	4 : 4 : 4 (YCbCr) 10bit		
	4 : 4 : 4 (RGB) 12bit		
	4 : 4 : 4 (YCbCr) 12bit		
1920 × 1080/24P <sup>1)</sup>	4 : 4 : 4 (RGB) 10bit	○	○
	4 : 4 : 4 (YCbCr) 10bit		
	4 : 4 : 4 (RGB) 12bit		
1920 × 1080/24PsF <sup>1)</sup>	4 : 4 : 4 (RGB) 10bit	○	○
	4 : 4 : 4 (YCbCr) 10bit		
	4 : 4 : 4 (RGB) 12bit		
	4 : 4 : 4 (YCbCr) 12bit		
2048 × 1080/60P <sup>1)</sup>	4 : 2 : 2 (YCbCr) 10bit	○	○
2048 × 1080/50P	4 : 2 : 2 (YCbCr) 10bit	○	○
2048 × 1080/48P <sup>1)</sup>	4 : 2 : 2 (YCbCr) 10bit	○	○
2048 × 1080/30P <sup>1)</sup>	4 : 4 : 4 (RGB) 10bit	○	○
	4 : 4 : 4 (YCbCr) 10bit		
	4 : 4 : 4 (RGB) 12bit		
	4 : 4 : 4 (YCbCr) 12bit		
2048 × 1080/30PsF <sup>1)</sup>	4 : 4 : 4 (RGB) 10bit	○	○
	4 : 4 : 4 (YCbCr) 10bit		
	4 : 4 : 4 (RGB) 12bit		
	4 : 4 : 4 (YCbCr) 12bit		
2048 × 1080/25P	4 : 4 : 4 (RGB) 10bit	○	○
	4 : 4 : 4 (YCbCr) 10bit		
	4 : 4 : 4 (RGB) 12bit		
	4 : 4 : 4 (YCbCr) 12bit		
2048 × 1080/25PsF	4 : 4 : 4 (RGB) 10bit	○	○
	4 : 4 : 4 (YCbCr) 10bit		
	4 : 4 : 4 (RGB) 12bit		
	4 : 4 : 4 (YCbCr) 12bit		
2048 × 1080/24P <sup>1)</sup>	4 : 4 : 4 (RGB) 10bit	○	○
	4 : 4 : 4 (YCbCr) 10bit		
	4 : 4 : 4 (RGB) 12bit		
2048 × 1080/24PsF <sup>1)</sup>	4 : 4 : 4 (RGB) 10bit	○	○
	4 : 4 : 4 (YCbCr) 10bit		
	4 : 4 : 4 (RGB) 12bit		
	4 : 4 : 4 (YCbCr) 12bit		
2048 × 1080/30P	4 : 4 : 4 (XYZ) 12bit	○	○
2048 × 1080/30PsF	4 : 4 : 4 (XYZ) 12bit	○	○
2048 × 1080/25P	4 : 4 : 4 (XYZ) 12bit	○	○
2048 × 1080/25PsF	4 : 4 : 4 (XYZ) 12bit	○	○
2048 × 1080/24P	4 : 4 : 4 (XYZ) 12bit	○	○

Signal System	Signal Structure		SDI 1	SDI 2
2048 × 1080/24PsF	4 : 4 : 4 (XYZ) 12bit		○	○
<b>2K/HD (3G-SDI)</b>				
Signal System	Signal Structure		SDI 1	SDI 2
1920 × 1080/60P <sup>1)</sup>	4 : 2 : 2 (YCbCr) 10bit	Level A/Level B-DL	○	○
1920 × 1080/50P	4 : 2 : 2 (YCbCr) 10bit	Level A/Level B-DL	○	○
1920 × 1080/60I <sup>1)</sup>	4 : 4 : 4 (RGB) 10bit	Level A/Level B-DL	○	○
	4 : 4 : 4 (YCbCr) 10bit			
	4 : 4 : 4 (RGB) 12bit			
1920 × 1080/50I	4 : 4 : 4 (YCbCr) 10bit	Level A/Level B-DL	○	○
	4 : 4 : 4 (RGB) 12bit			
	4 : 4 : 4 (YCbCr) 12bit			
1920 × 1080/30P <sup>1)</sup>	4 : 4 : 4 (RGB) 10bit	Level A/Level B-DL	○	○
	4 : 4 : 4 (YCbCr) 10bit			
	4 : 4 : 4 (RGB) 12bit			
1920 × 1080/30PsF <sup>1)</sup>	4 : 4 : 4 (YCbCr) 10bit	Level A/Level B-DL	○	○
	4 : 4 : 4 (RGB) 12bit			
	4 : 4 : 4 (YCbCr) 12bit			
1920 × 1080/25P	4 : 4 : 4 (YCbCr) 10bit	Level A/Level B-DL	○	○
	4 : 4 : 4 (RGB) 12bit			
	4 : 4 : 4 (YCbCr) 12bit			
1920 × 1080/25PsF	4 : 4 : 4 (RGB) 10bit	Level A/Level B-DL	○	○
	4 : 4 : 4 (YCbCr) 10bit			
	4 : 4 : 4 (RGB) 12bit			
1920 × 1080/24P <sup>1)</sup>	4 : 4 : 4 (YCbCr) 10bit	Level A/Level B-DL	○	○
	4 : 4 : 4 (RGB) 12bit			
	4 : 4 : 4 (YCbCr) 12bit			
1920 × 1080/24PsF <sup>1)</sup>	4 : 4 : 4 (YCbCr) 10bit	Level A/Level B-DL	○	○
	4 : 4 : 4 (RGB) 12bit			
	4 : 4 : 4 (YCbCr) 12bit			
1280 × 720/60P <sup>1)</sup>	4 : 4 : 4 (RGB) 10bit	Level-A	○	○
	4 : 4 : 4 (YCbCr) 10bit			
1280 × 720/50P	4 : 4 : 4 (RGB) 10bit	Level-A	○	○
	4 : 4 : 4 (YCbCr) 10bit			
1280 × 720/30P <sup>1)</sup>	4 : 4 : 4 (RGB) 10bit	Level-A	○	○
	4 : 4 : 4 (YCbCr) 10bit			
1280 × 720/25P	4 : 4 : 4 (RGB) 10bit	Level-A	○	○
	4 : 4 : 4 (YCbCr) 10bit			
1280 × 720/24P <sup>1)</sup>	4 : 4 : 4 (RGB) 10bit	Level-A	○	○
	4 : 4 : 4 (YCbCr) 10bit			

Signal System	Signal Structure	SDI 1	SDI 2
2048 × 1080/60P <sup>1)</sup>	4 : 2 : 2 (YCbCr) 10bit	Level A/Level B-DL	○ ○
2048 × 1080/50P	4 : 2 : 2 (YCbCr) 10bit	Level A/Level B-DL	○ ○
2048 × 1080/48P <sup>1)</sup>	4 : 2 : 2 (YCbCr) 10bit	Level A/Level B-DL	○ ○
2048 × 1080/30P <sup>1)</sup>	4 : 4 : 4 (RGB) 10bit	Level A/Level B-DL	○ ○
	4 : 4 : 4 (YCbCr) 10bit		
	4 : 4 : 4 (RGB) 12bit		
	4 : 4 : 4 (YCbCr) 12bit		
2048 × 1080/30PsF <sup>1)</sup>	4 : 4 : 4 (RGB) 10bit	Level A/Level B-DL	○ ○
	4 : 4 : 4 (YCbCr) 10bit		
	4 : 4 : 4 (RGB) 12bit		
	4 : 4 : 4 (YCbCr) 12bit		
2048 × 1080/25P	4 : 4 : 4 (RGB) 10bit	Level A/Level B-DL	○ ○
	4 : 4 : 4 (YCbCr) 10bit		
	4 : 4 : 4 (RGB) 12bit		
	4 : 4 : 4 (YCbCr) 12bit		
2048 × 1080/25PsF	4 : 4 : 4 (RGB) 10bit	Level A/Level B-DL	○ ○
	4 : 4 : 4 (YCbCr) 10bit		
	4 : 4 : 4 (RGB) 12bit		
	4 : 4 : 4 (YCbCr) 12bit		
2048 × 1080/24P <sup>1)</sup>	4 : 4 : 4 (RGB) 10bit	Level A/Level B-DL	○ ○
	4 : 4 : 4 (YCbCr) 10bit		
	4 : 4 : 4 (RGB) 12bit		
	4 : 4 : 4 (YCbCr) 12bit		
2048 × 1080/24PsF <sup>1)</sup>	4 : 4 : 4 (RGB) 10bit	Level A/Level B-DL	○ ○
	4 : 4 : 4 (YCbCr) 10bit		
	4 : 4 : 4 (RGB) 12bit		
	4 : 4 : 4 (YCbCr) 12bit		
2048 × 1080/30P	4 : 4 : 4 (XYZ) 12bit	Level A/Level B-DL	○ ○
2048 × 1080/30PsF	4 : 4 : 4 (XYZ) 12bit	Level A/Level B-DL	○ ○
2048 × 1080/25P	4 : 4 : 4 (XYZ) 12bit	Level A/Level B-DL	○ ○
2048 × 1080/25PsF	4 : 4 : 4 (XYZ) 12bit	Level A/Level B-DL	○ ○
2048 × 1080/24P	4 : 4 : 4 (XYZ) 12bit	Level A/Level B-DL	○ ○
2048 × 1080/24PsF	4 : 4 : 4 (XYZ) 12bit	Level A/Level B-DL	○ ○

## 2K/HD (3G-SDI Dual Link)

Signal System	Signal Structure	SDI 1	SDI 2
1920 × 1080/60P <sup>1)</sup>	4 : 4 : 4 (RGB) 10bit	Level A/Level B-DL	○ ○
	4 : 4 : 4 (YCbCr) 10bit		
	4 : 4 : 4 (RGB) 12bit		
	4 : 4 : 4 (YCbCr) 12bit		
1920 × 1080/50P	4 : 4 : 4 (RGB) 10bit	Level A/Level B-DL	○ ○
	4 : 4 : 4 (YCbCr) 10bit		
	4 : 4 : 4 (RGB) 12bit		
	4 : 4 : 4 (YCbCr) 12bit		
2048 × 1080/60P <sup>1)</sup>	4 : 4 : 4 (RGB) 10bit	Level A/Level B-DL	○ ○
	4 : 4 : 4 (YCbCr) 10bit		
	4 : 4 : 4 (RGB) 12bit		
	4 : 4 : 4 (YCbCr) 12bit		

Signal System	Signal Structure		SDI 1	SDI 2
2048 × 1080/50P	4 : 4 : 4 (RGB) 10bit	Level A/Level B-DL	○	○
	4 : 4 : 4 (YCbCr) 10bit			
	4 : 4 : 4 (RGB) 12bit			
	4 : 4 : 4 (YCbCr) 12bit			
2048 × 1080/48P <sup>1)</sup>	4 : 4 : 4 (RGB) 10bit	Level A/Level B-DL	○	○
	4 : 4 : 4 (YCbCr) 10bit			
	4 : 4 : 4 (RGB) 12bit			
	4 : 4 : 4 (YCbCr) 12bit			

#### 4K/UHD (HD-SDI Quad Link)

Signal System	Signal Structure		SDI 1	SDI 2
3840 × 2160/30P <sup>1)</sup>	4 : 2 : 2 (YCbCr) 10bit	Square	○	○
3840 × 2160/30PsF <sup>1)</sup>	4 : 2 : 2 (YCbCr) 10bit	Square	○	○
3840 × 2160/25P	4 : 2 : 2 (YCbCr) 10bit	Square	○	○
3840 × 2160/25PsF	4 : 2 : 2 (YCbCr) 10bit	Square	○	○
3840 × 2160/24P <sup>1)</sup>	4 : 2 : 2 (YCbCr) 10bit	Square	○	○
3840 × 2160/24PsF <sup>1)</sup>	4 : 2 : 2 (YCbCr) 10bit	Square	○	○
4096 × 2160/30P <sup>1)</sup>	4 : 2 : 2 (YCbCr) 10bit	Square	○	○
4096 × 2160/30PsF <sup>1)</sup>	4 : 2 : 2 (YCbCr) 10bit	Square	○	○
4096 × 2160/25P	4 : 2 : 2 (YCbCr) 10bit	Square	○	○
4096 × 2160/25PsF	4 : 2 : 2 (YCbCr) 10bit	Square	○	○
4096 × 2160/24P <sup>1)</sup>	4 : 2 : 2 (YCbCr) 10bit	Square	○	○
4096 × 2160/24PsF <sup>1)</sup>	4 : 2 : 2 (YCbCr) 10bit	Square	○	○

#### 4K/UHD (3G-SDI Dual Link)

Signal System	Signal Structure		SDI 1	SDI 2
3840 × 2160/30P <sup>1)</sup>	4 : 2 : 2 (YCbCr) 10bit	Level B-DS <sup>2)</sup> Square/2SI	○	○
3840 × 2160/30PsF <sup>1)</sup>	4 : 2 : 2 (YCbCr) 10bit	Level B-DS <sup>2)</sup> Square	○	○
3840 × 2160/25P	4 : 2 : 2 (YCbCr) 10bit	Level B-DS <sup>2)</sup> Square/2SI	○	○
3840 × 2160/25PsF	4 : 2 : 2 (YCbCr) 10bit	Level B-DS <sup>2)</sup> Square	○	○
3840 × 2160/24P <sup>1)</sup>	4 : 2 : 2 (YCbCr) 10bit	Level B-DS <sup>2)</sup> Square/2SI	○	○
3840 × 2160/24PsF <sup>1)</sup>	4 : 2 : 2 (YCbCr) 10bit	Level B-DS <sup>2)</sup> Square	○	○
4096 × 2160/30P <sup>1)</sup>	4 : 2 : 2 (YCbCr) 10bit	Level B-DS <sup>2)</sup> Square/2SI	○	○
4096 × 2160/30PsF <sup>1)</sup>	4 : 2 : 2 (YCbCr) 10bit	Level B-DS <sup>2)</sup> Square	○	○
4096 × 2160/25P	4 : 2 : 2 (YCbCr) 10bit	Level B-DS <sup>2)</sup> Square/2SI	○	○
4096 × 2160/25PsF	4 : 2 : 2 (YCbCr) 10bit	Level B-DS <sup>2)</sup> Square	○	○
4096 × 2160/24P <sup>1)</sup>	4 : 2 : 2 (YCbCr) 10bit	Level B-DS <sup>2)</sup> Square/2SI	○	○
4096 × 2160/24PsF <sup>1)</sup>	4 : 2 : 2 (YCbCr) 10bit	Level B-DS <sup>2)</sup> Square	○	○

#### 4K/UHD (3G-SDI Quad Link)

Signal System	Signal Structure		SDI 1	SDI 2
3840 × 2160/60P <sup>1)</sup>	4 : 2 : 2 (YCbCr) 10bit	Level A/Level B-DL Square/2SI	○	○
3840 × 2160/50P	4 : 2 : 2 (YCbCr) 10bit	Level A/Level B-DL Square/2SI	○	○
3840 × 2160/30P <sup>1)</sup>	4 : 4 : 4 (RGB) 10bit	Level A/Level B-DL Square/2SI	○	○
	4 : 4 : 4 (YCbCr) 10bit			
	4 : 4 : 4 (RGB) 12bit			
	4 : 4 : 4 (YCbCr) 12bit			

Signal System	Signal Structure			SDI 1	SDI 2
3840 × 2160/30PsF <sup>1)</sup>	4 : 4 : 4 (RGB) 10bit	Level A/Level B-DL	Square	○	○
	4 : 4 : 4 (YCbCr) 10bit				
	4 : 4 : 4 (RGB) 12bit				
	4 : 4 : 4 (YCbCr) 12bit				
3840 × 2160/25P	4 : 4 : 4 (RGB) 10bit	Level A/Level B-DL	Square/2SI	○	○
	4 : 4 : 4 (YCbCr) 10bit				
	4 : 4 : 4 (RGB) 12bit				
	4 : 4 : 4 (YCbCr) 12bit				
3840 × 2160/25PsF	4 : 4 : 4 (RGB) 10bit	Level A/Level B-DL	Square	○	○
	4 : 4 : 4 (YCbCr) 10bit				
	4 : 4 : 4 (RGB) 12bit				
	4 : 4 : 4 (YCbCr) 12bit				
3840 × 2160/24P <sup>1)</sup>	4 : 4 : 4 (RGB) 10bit	Level A/Level B-DL	Square/2SI	○	○
	4 : 4 : 4 (YCbCr) 10bit				
	4 : 4 : 4 (RGB) 12bit				
	4 : 4 : 4 (YCbCr) 12bit				
3840 × 2160/24PsF <sup>1)</sup>	4 : 4 : 4 (RGB) 10bit	Level A/Level B-DL	Square	○	○
	4 : 4 : 4 (YCbCr) 10bit				
	4 : 4 : 4 (RGB) 12bit				
	4 : 4 : 4 (YCbCr) 12bit				
4096 × 2160/60P <sup>1)</sup>	4 : 2 : 2 (YCbCr) 10bit	Level A/Level B-DL	Square/2SI	○	○
4096 × 2160/50P	4 : 2 : 2 (YCbCr) 10bit	Level A/Level B-DL	Square/2SI	○	○
4096 × 2160/48P <sup>1)</sup>	4 : 2 : 2 (YCbCr) 10bit	Level A/Level B-DL	Square/2SI	○	○
4096 × 2160/30P <sup>1)</sup>	4 : 4 : 4 (RGB) 10bit	Level A/Level B-DL	Square/2SI	○	○
	4 : 4 : 4 (YCbCr) 10bit				
	4 : 4 : 4 (RGB) 12bit				
	4 : 4 : 4 (YCbCr) 12bit				
4096 × 2160/30PsF <sup>1)</sup>	4 : 4 : 4 (RGB) 10bit	Level A/Level B-DL	Square	○	○
	4 : 4 : 4 (YCbCr) 10bit				
	4 : 4 : 4 (RGB) 12bit				
	4 : 4 : 4 (YCbCr) 12bit				
4096 × 2160/25P	4 : 4 : 4 (RGB) 10bit	Level A/Level B-DL	Square/2SI	○	○
	4 : 4 : 4 (YCbCr) 10bit				
	4 : 4 : 4 (RGB) 12bit				
	4 : 4 : 4 (YCbCr) 12bit				
4096 × 2160/25PsF	4 : 4 : 4 (RGB) 10bit	Level A/Level B-DL	Square	○	○
	4 : 4 : 4 (YCbCr) 10bit				
	4 : 4 : 4 (RGB) 12bit				
	4 : 4 : 4 (YCbCr) 12bit				
4096 × 2160/24P <sup>1)</sup>	4 : 4 : 4 (RGB) 10bit	Level A/Level B-DL	Square/2SI	○	○
	4 : 4 : 4 (YCbCr) 10bit				
	4 : 4 : 4 (RGB) 12bit				
	4 : 4 : 4 (YCbCr) 12bit				
4096 × 2160/24PsF <sup>1)</sup>	4 : 4 : 4 (RGB) 10bit	Level A/Level B-DL	Square	○	○
	4 : 4 : 4 (YCbCr) 10bit				
	4 : 4 : 4 (RGB) 12bit				
	4 : 4 : 4 (YCbCr) 12bit				
4096 × 2160/30P	4 : 4 : 4 (XYZ) 12bit	Level A/Level B-DL	Square/2SI	○	○

Signal System	Signal Structure				SDI 1	SDI 2
4096 × 2160/30PsF	4 : 4 : 4 (XYZ)	12bit	Level A/Level B-DL	Square	○	○
4096 × 2160/25P	4 : 4 : 4 (XYZ)	12bit	Level A/Level B-DL	Square/2SI	○	○
4096 × 2160/25PsF	4 : 4 : 4 (XYZ)	12bit	Level A/Level B-DL	Square	○	○
4096 × 2160/24P	4 : 4 : 4 (XYZ)	12bit	Level A/Level B-DL	Square/2SI	○	○
4096 × 2160/24PsF	4 : 4 : 4 (XYZ)	12bit	Level A/Level B-DL	Square	○	○

#### 4K/UHD (6G-SDI Single Link)

Signal System	Signal Structure				SDI 1	SDI 2
3840 × 2160/30P <sup>1)</sup>	4 : 2 : 2 (YCbCr)	10bit	Mode 1	Square/2SI		○
3840 × 2160/25P	4 : 2 : 2 (YCbCr)	10bit	Mode 1	Square/2SI		○
3840 × 2160/24P <sup>1)</sup>	4 : 2 : 2 (YCbCr)	10bit	Mode 1	Square/2SI		○
4096 × 2160/30P <sup>1)</sup>	4 : 2 : 2 (YCbCr)	10bit	Mode 1	Square/2SI		○
4096 × 2160/25P	4 : 2 : 2 (YCbCr)	10bit	Mode 1	Square/2SI		○
4096 × 2160/24P <sup>1)</sup>	4 : 2 : 2 (YCbCr)	10bit	Mode 1	Square/2SI		○

#### 4K/UHD (12G-SDI Single Link)

Signal System	Signal Structure				SDI 1	SDI 2
3840 × 2160/60P <sup>1)</sup>	4 : 2 : 2 (YCbCr)	10bit	Mode 1	Square/2SI		○
3840 × 2160/50P	4 : 2 : 2 (YCbCr)	10bit	Mode 1	Square/2SI		○
3840 × 2160/30P <sup>1)</sup>	4 : 4 : 4 (RGB)	10bit	Mode 1	Square/2SI		○
	4 : 4 : 4 (YCbCr)	10bit				
	4 : 4 : 4 (RGB)	12bit				
	4 : 4 : 4 (YCbCr)	12bit				
3840 × 2160/25P	4 : 4 : 4 (RGB)	10bit	Mode 1	Square/2SI		○
	4 : 4 : 4 (YCbCr)	10bit				
	4 : 4 : 4 (RGB)	12bit				
	4 : 4 : 4 (YCbCr)	12bit				
3840 × 2160/24P <sup>1)</sup>	4 : 4 : 4 (RGB)	10bit	Mode 1	Square/2SI		○
	4 : 4 : 4 (YCbCr)	10bit				
	4 : 4 : 4 (RGB)	12bit				
	4 : 4 : 4 (YCbCr)	12bit				
4096 × 2160/60P <sup>1)</sup>	4 : 2 : 2 (YCbCr)	10bit	Mode 1	Square/2SI		○
4096 × 2160/50P	4 : 2 : 2 (YCbCr)	10bit	Mode 1	Square/2SI		○
4096 × 2160/48P <sup>1)</sup>	4 : 2 : 2 (YCbCr)	10bit	Mode 1	Square/2SI		○
4096 × 2160/30P <sup>1)</sup>	4 : 4 : 4 (RGB)	10bit	Mode 1	Square/2SI		○
	4 : 4 : 4 (YCbCr)	10bit				
	4 : 4 : 4 (RGB)	12bit				
	4 : 4 : 4 (YCbCr)	12bit				
4096 × 2160/25P	4 : 4 : 4 (RGB)	10bit	Mode 1	Square/2SI		○
	4 : 4 : 4 (YCbCr)	10bit				
	4 : 4 : 4 (RGB)	12bit				
	4 : 4 : 4 (YCbCr)	12bit				
4096 × 2160/24P <sup>1)</sup>	4 : 4 : 4 (RGB)	10bit	Mode 1	Square/2SI		○
	4 : 4 : 4 (YCbCr)	10bit				
	4 : 4 : 4 (RGB)	12bit				
	4 : 4 : 4 (YCbCr)	12bit				
4096 × 2160/30P	4 : 4 : 4 (XYZ)	12bit	Mode 1	Square/2SI		○
4096 × 2160/25P	4 : 4 : 4 (XYZ)	12bit	Mode 1	Square/2SI		○

Signal System	Signal Structure	SDI 1	SDI 2
4096 × 2160/24P	4 : 4 : 4 (XYZ) 12bit Mode 1 Square/2SI		○

1) Also compatible with 1/1.001.

2) When Square is selected (physically same when 2SI is selected).

## HDMI

Signal System	Signal Structure	HDMI
640 × 480/60P <sup>1)</sup>	4 : 4 : 4 (RGB) 12/10/8bit	○
	4 : 4 : 4 (YCbCr) 12/10/8bit	
	4 : 2 : 2 (YCbCr) 12bit	
720 × 480/60P <sup>1)</sup>	4 : 4 : 4 (RGB) 12/10/8bit	○
	4 : 4 : 4 (YCbCr) 12/10/8bit	
	4 : 2 : 2 (YCbCr) 12bit	
1280 × 720/60P <sup>1)</sup>	4 : 4 : 4 (RGB) 12/10/8bit	○
	4 : 4 : 4 (YCbCr) 12/10/8bit	
	4 : 2 : 2 (YCbCr) 12bit	
1920 × 1080/60I <sup>1)</sup>	4 : 4 : 4 (RGB) 12/10/8bit	○
	4 : 4 : 4 (YCbCr) 12/10/8bit	
	4 : 2 : 2 (YCbCr) 12bit	
720 × 576/50P	4 : 4 : 4 (RGB) 12/10/8bit	○
	4 : 4 : 4 (YCbCr) 12/10/8bit	
	4 : 2 : 2 (YCbCr) 12bit	
1280 × 720/50P	4 : 4 : 4 (RGB) 12/10/8bit	○
	4 : 4 : 4 (YCbCr) 12/10/8bit	
	4 : 2 : 2 (YCbCr) 12bit	
1920 × 1080/50I	4 : 4 : 4 (RGB) 12/10/8bit	○
	4 : 4 : 4 (YCbCr) 12/10/8bit	
	4 : 2 : 2 (YCbCr) 12bit	
1920 × 1080/60P <sup>1)</sup>	4 : 4 : 4 (RGB) 12/10/8bit	○
	4 : 4 : 4 (YCbCr) 12/10/8bit	
	4 : 2 : 2 (YCbCr) 12bit	
1920 × 1080/50P	4 : 4 : 4 (RGB) 12/10/8bit	○
	4 : 4 : 4 (YCbCr) 12/10/8bit	
	4 : 2 : 2 (YCbCr) 12bit	
1920 × 1080/30P <sup>1)</sup>	4 : 4 : 4 (RGB) 12/10/8bit	○
	4 : 4 : 4 (YCbCr) 12/10/8bit	
	4 : 2 : 2 (YCbCr) 12bit	
1920 × 1080/25P	4 : 4 : 4 (RGB) 12/10/8bit	○
	4 : 4 : 4 (YCbCr) 12/10/8bit	
	4 : 2 : 2 (YCbCr) 12bit	
1920 × 1080/24P <sup>1)</sup>	4 : 4 : 4 (RGB) 12/10/8bit	○
	4 : 4 : 4 (YCbCr) 12/10/8bit	
	4 : 2 : 2 (YCbCr) 12bit	
2048 × 1080/60P <sup>1)</sup>	4 : 4 : 4 (RGB) 12/10/8bit	○
	4 : 4 : 4 (YCbCr) 12/10/8bit	
	4 : 2 : 2 (YCbCr) 12bit	
2048 × 1080/50P	4 : 4 : 4 (RGB) 12/10/8bit	○
	4 : 4 : 4 (YCbCr) 12/10/8bit	
	4 : 2 : 2 (YCbCr) 12bit	

Signal System	Signal Structure	HDMI
2048 × 1080/48P	4 : 4 : 4 (RGB) 12/10/8bit	○
	4 : 4 : 4 (YCbCr) 12/10/8bit	
	4 : 2 : 2 (YCbCr) 12bit	
2048 × 1080/30P <sup>1) 6)</sup>	4 : 4 : 4 (RGB) 12/10/8bit	○
	4 : 4 : 4 (YCbCr) 12/10/8bit	
	4 : 2 : 2 (YCbCr) 12bit	
2048 × 1080/25P <sup>6)</sup>	4 : 4 : 4 (RGB) 12/10/8bit	○
	4 : 4 : 4 (YCbCr) 12/10/8bit	
	4 : 2 : 2 (YCbCr) 12bit	
2048 × 1080/24P <sup>1)</sup>	4 : 4 : 4 (RGB) 12/10/8bit	○
	4 : 4 : 4 (YCbCr) 12/10/8bit	
	4 : 2 : 2 (YCbCr) 12bit	
3840 × 2160/30P <sup>1) 2)</sup>	4 : 4 : 4 (RGB) 12/10/8bit <sup>3) 5)</sup>	○
	4 : 4 : 4 (YCbCr) 12/10/8bit <sup>3) 4)</sup>	
	4 : 2 : 2 (YCbCr) 12bit	
3840 × 2160/25P <sup>2)</sup>	4 : 4 : 4 (RGB) 12/10/8bit <sup>3) 5)</sup>	○
	4 : 4 : 4 (YCbCr) 12/10/8bit <sup>3) 4)</sup>	
	4 : 2 : 2 (YCbCr) 12bit	
3840 × 2160/24P <sup>1) 2)</sup>	4 : 4 : 4 (RGB) 12/10/8bit <sup>3) 5)</sup>	○
	4 : 4 : 4 (YCbCr) 12/10/8bit <sup>3) 4)</sup>	
	4 : 2 : 2 (YCbCr) 12bit	
4096 × 2160/30P <sup>1) 2)</sup>	4 : 4 : 4 (RGB) 12/10/8bit <sup>3) 5)</sup>	○
	4 : 4 : 4 (YCbCr) 12/10/8bit <sup>3) 4)</sup>	
	4 : 2 : 2 (YCbCr) 12bit	
4096 × 2160/25P <sup>2)</sup>	4 : 4 : 4 (RGB) 12/10/8bit <sup>3) 5)</sup>	○
	4 : 4 : 4 (YCbCr) 12/10/8bit <sup>3) 4)</sup>	
	4 : 2 : 2 (YCbCr) 12bit	
4096 × 2160/24P <sup>1) 2)</sup>	4 : 4 : 4 (RGB) 12/10/8bit <sup>3) 5)</sup>	○
	4 : 4 : 4 (YCbCr) 12/10/8bit <sup>3) 4)</sup>	
	4 : 2 : 2 (YCbCr) 12bit	
3840 × 2160/60P <sup>1) 2)</sup>	4 : 4 : 4 (RGB) 8bit <sup>3)</sup>	○
	4 : 4 : 4 (YCbCr) 8bit <sup>3)</sup>	
	4 : 2 : 2 (YCbCr) 12bit <sup>3)</sup>	
	4 : 2 : 0 (YCbCr) 8bit	
3840 × 2160/50P <sup>2)</sup>	4 : 4 : 4 (RGB) 8bit <sup>3)</sup>	○
	4 : 4 : 4 (YCbCr) 8bit <sup>3)</sup>	
	4 : 2 : 2 (YCbCr) 12bit <sup>3)</sup>	
	4 : 2 : 0 (YCbCr) 8bit	
4096 × 2160/60P <sup>1) 2)</sup>	4 : 4 : 4 (RGB) 8bit <sup>3)</sup>	○
	4 : 4 : 4 (YCbCr) 8bit <sup>3)</sup>	
	4 : 2 : 2 (YCbCr) 12bit <sup>3)</sup>	
	4 : 2 : 0 (YCbCr) 8bit	
4096 × 2160/50P <sup>2)</sup>	4 : 4 : 4 (RGB) 8bit <sup>3)</sup>	○
	4 : 4 : 4 (YCbCr) 8bit <sup>3)</sup>	
	4 : 2 : 2 (YCbCr) 12bit <sup>3)</sup>	
	4 : 2 : 0 (YCbCr) 8bit	

Signal System	Signal Structure	HDMI
800 × 600/60P	4 : 4 : 4 (RGB) 12/10/8bit	○
	4 : 4 : 4 (YCbCr) 12/10/8bit	
	4 : 2 : 2 (YCbCr) 12bit	
1024 × 768/60P	4 : 4 : 4 (RGB) 12/10/8bit	○
	4 : 4 : 4 (YCbCr) 12/10/8bit	
	4 : 2 : 2 (YCbCr) 12bit	

- 1) Also compatible with the frame rate 1/1.001.
- 2) This signal is described as "equivalent to the 4K signal" in this manual.
- 3) "Enhanced Format" must be selected in the "HDMI Signal Format" (page 29). Also, when using this input signal, use the Premium High-Speed HDMI cable. (30P, 25P, 24P signals are only for the 4:4:4 RGB/YCbCr 10/12bit signal.)
- 4) The 4:4:4(YCbCr)12/10bit signal is displayed after converting to the 4:2:2(YCbCr)12/10bit signal.
- 5) The 4:4:4(RGB)12/10bit signal is displayed as a 4:4:4(RGB)8bit signal.
- 6) This signal system is not described in EDID (Extended Display Identification Data).

# Dimensions

## Front

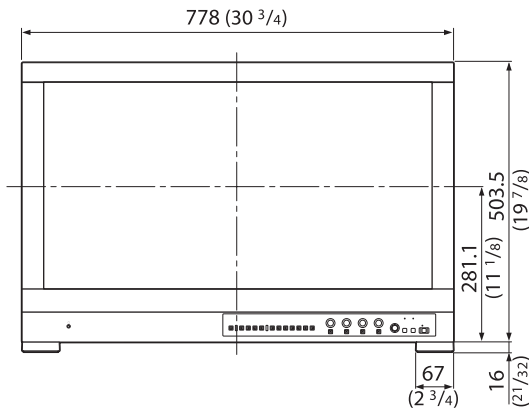

## Rear

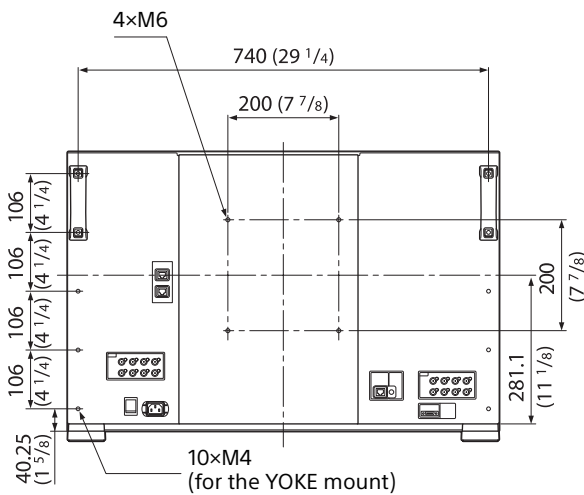

To install on a vehicle, fix the unit using screw holes for the YOKE mount.

## Side

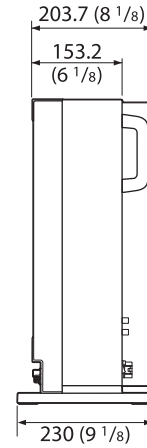

Unit: mm (inches)

Mass: Approx. 29 kg (63 lb 15 oz)

### \* Length of M4 screws (rear)

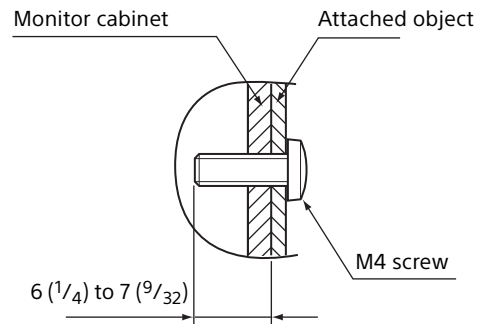

### \* Length of M6 screws (rear)

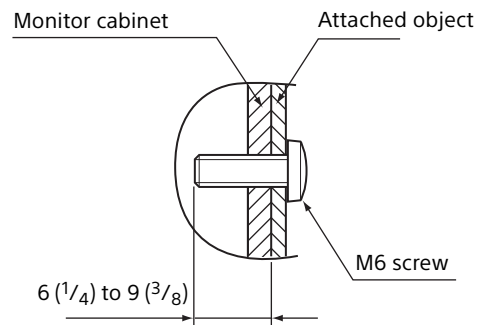

Unit: mm (inches)

### Notes

- Make sure to tighten the screws using the screwdriver which conforms to the supplied screws.
- When using an electric screwdriver, set the torque setting as follows.  
For M4 screws: approximately 1.2 N·m [12 kgf·cm]  
For M6 screws: approximately 1.5 N·m [15 kgf·cm]

