



Lenovo Mirage Camera with Daydream

User Guide

Basics

- All pictures and illustrations in this document are for reference only.
- The VR180 app supports both Android and iOS systems. This document uses the Android system as an illustrative example.

Before using this information and the product it supports, be sure to read the following:

- **Quick Start Guide and Safety & Warranty**
- **Regulatory Notice**
- **Important safety and handling information in Appendix**

This device contains labels to indicate physical tampering or liquid damage. If evidence of tampering or liquid damage is found during service, this will void the terms of the product warranty.

The Safety, Warranty & Product Guide and the Regulatory Notice are available at

<http://support.lenovo.com/jedichallenges>.

Getting started

Overview

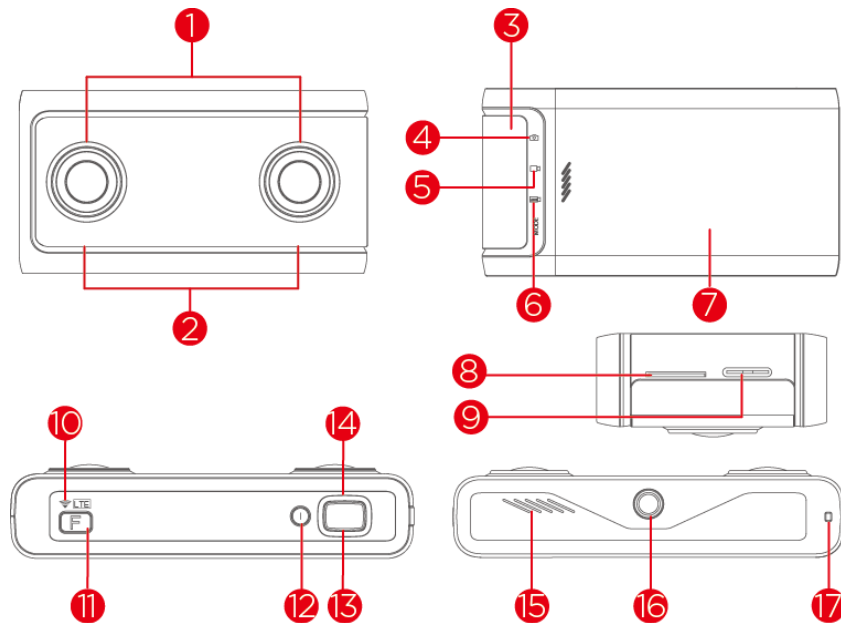

1	Lenses	2	Dual microphones	3	Input/output door
4	VR photos	5	VR videos	6	VR live streaming
7	Battery cover	8	microSD card slot	9	USB-C 2.0 port

10	Wi-Fi indicator	11	Function button	12	Power button
13	Shutter button	14	Status indicator	15	Speaker
16	Accessory socket	17	Wrist strap holes		

Downloading the VR180 app by Google

1. Open the Google Play Store or App Store in your mobile device.
2. Search for **VR180 app by Google**.
3. Download the VR180 app by Google.



Search for the **VR180 by Google**

Turning on/off

Turn on

Tap the power button. The status indicator blinks in green, then glows in blue a few seconds later.

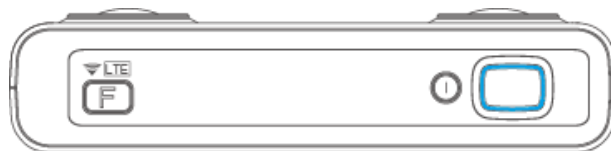

Turn off

Press and hold the power button until the indicator turns off.



In the standby mode, the camera will automatically shut down if there is no operation within 2 hours.

Sleep/wake up

- **Sleep:** The camera will automatically enter Sleep mode if there is no operation within 5 minutes when it does not connect with the VR180 app. At this time, the camera cannot take photos or record videos..
- **Wake up:** tap the Power button to wake up the camera.

Status indicator

Camera state	Battery percent	Indicator
Standby	Battery percent > 20%	Blue
	Battery percent ≤ 20%	Red
The camera is pairing	/	Flashes blue and green
The camera is powering on /updating firmware	/	Flashes green
The camera is recording video	Battery percent > 20%	Flashes blue
	Battery percent ≤ 20%	Flashes red
The camera is charging and recording video	Battery percent = 100%	Flashes blue
	Battery percent < 100%	Flashes orange
The camera is charging	Battery percent = 100%	Blue
	Battery percent < 100%	Orange
Camera failure	/	Quickly flashes red 3 times

-  Please do not perform any operation while updating the firmware to prevent damage to the device.

Connecting the camera to a mobile device using the VR180 app

1. Open the VR180 app.
2. Turn on your mobile device's Bluetooth.
3. Follow the onscreen steps in the app to pair your camera and mobile device to finish.

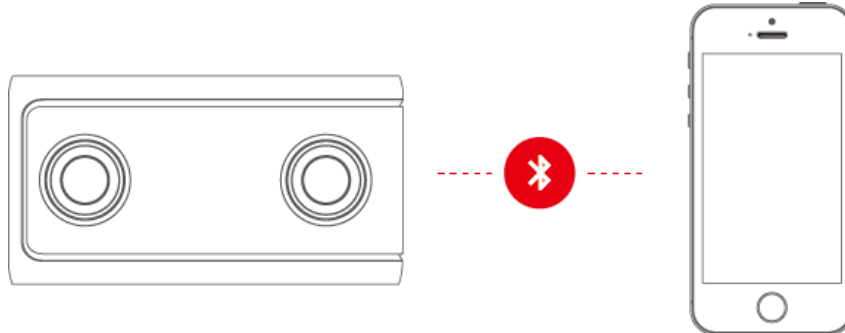

Connecting the camera to the Internet

You'll need to regularly connect your camera to the Internet using the VR180 app to get the latest camera software updates.

1. Open the VR180 app.
2. Ensure your camera is paired with Bluetooth.
3. Follow the prompts to connect your camera to Wi-Fi.

Using the camera

Taking photos/recording videos

The camera can take photos/record videos without connecting to another device.

- 1、 Turn on the camera.
 - 2、 Tap the Function button to choose shooting mode.
 - 3、 Focus the lens on the object to be shot.
 - 4、 Tap the shutter button to take photos or record videos.
- The camera's shooting coverage is larger than the visual range of human eyes.
 - Please do not extend your fingers beyond the edge of the camera when shooting.

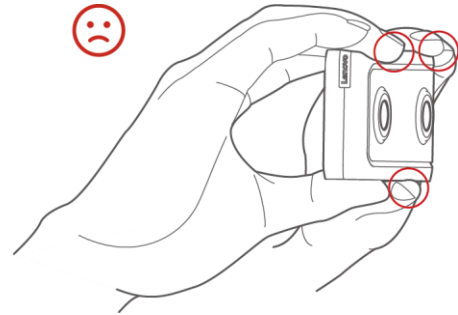
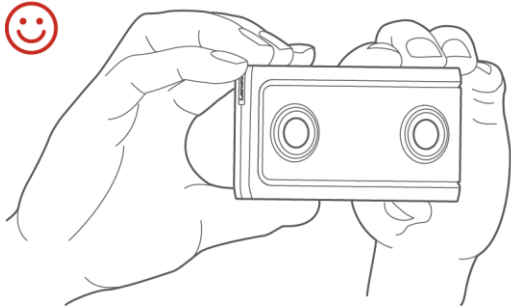

Shooting coverage

The camera's shooting coverage is 180° in both the horizontal and vertical directions.

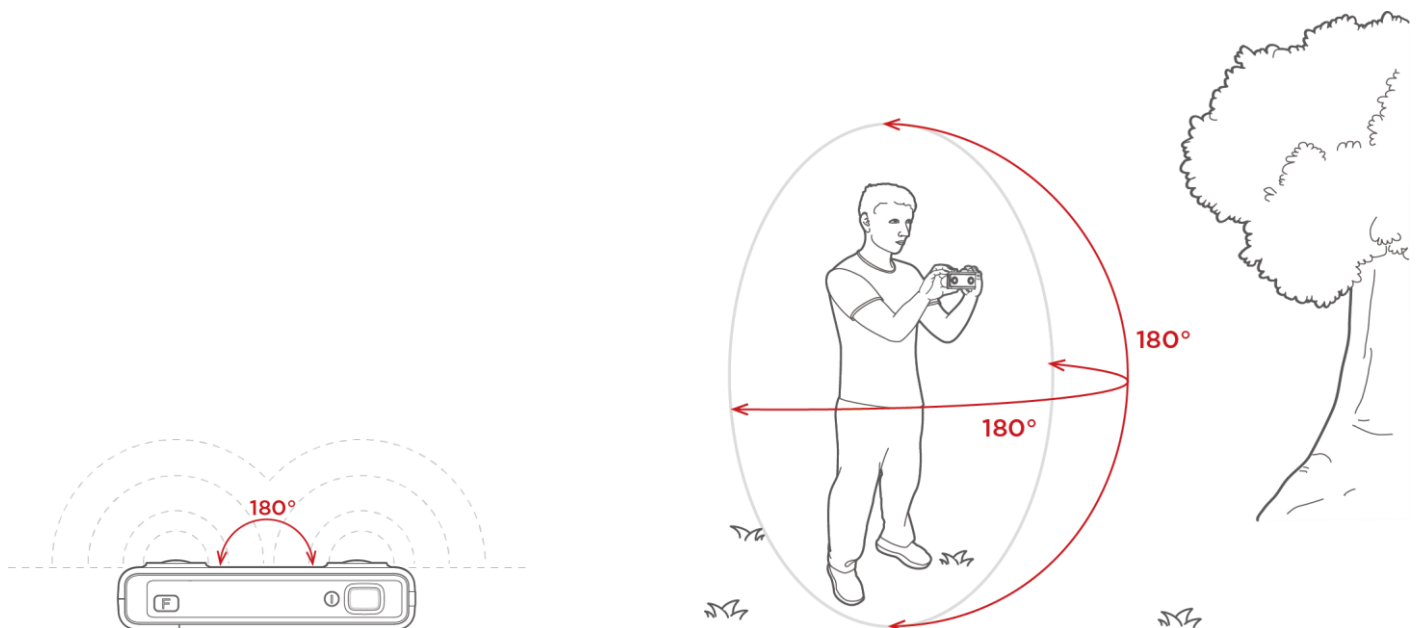

Shooting distance



When shooting, keep the camera and the object to be shot the correct distance from each other to get the best 3D effect. **The best recommended distance is x m - x m.**

- The 3D effect will decrease as the shooting distance increases.
- When the shooting distance is too short, viewing photos / videos will produce discomfort.

Use VR180 app

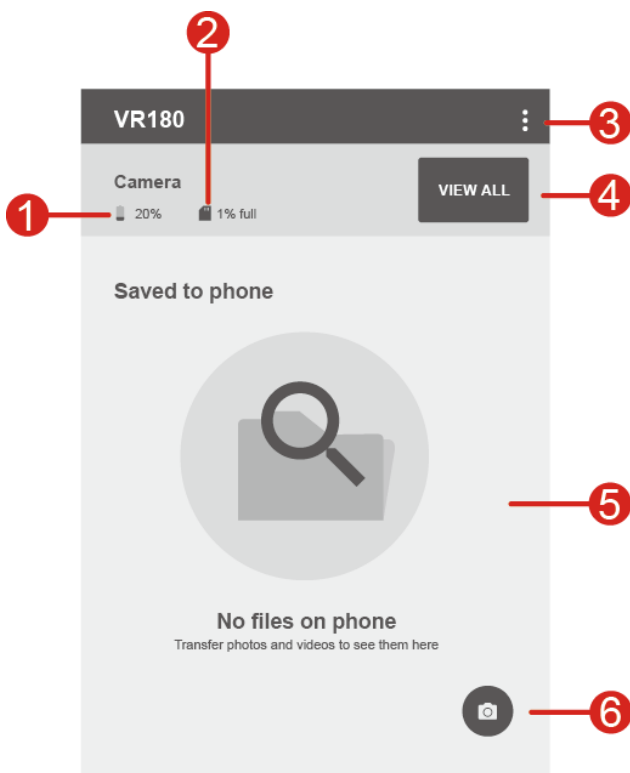
Use main interface



1	Displays the battery charge percentage.
2	The used storage space can be viewed.
3	Tap  to perform the following operations: <ul style="list-style-type: none">• Choose to delete the photos/videos saved in the mobile device.• Other settings.
4	Tap VIEW ALL to view all of the photos or videos.
5	The photos / videos downloaded to the mobile device can be viewed.
6	Tap  to enter the shooting interface.

Shooting interface

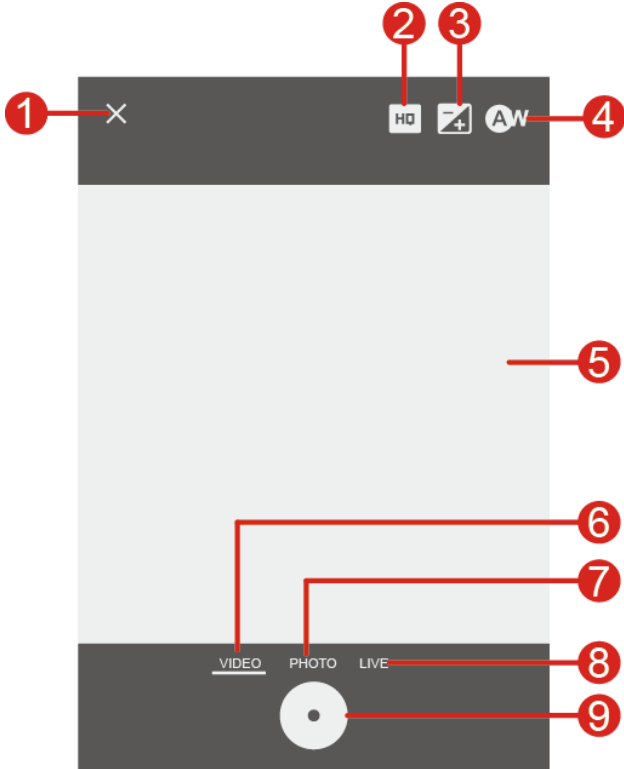

1	Tap to exit the Shooting interface.
2	Tap to switch the video resolution.
3	Tap to manually adjust the exposure value.
4	Tap to choose the shooting mode.
5	Preview interface.
6	Tap VIDEO to switch to video mode.
7	Tap PHOTO to switch to photo mode.
8	Tap LIVE to switch to live mode.
9	Shooting button.

Connect the VR180 app to take photos

1. Start the VR180 app, tap > **PHOTO**.
2. Focus the lens on the object to be shot.
3. Tap .

Connect the VR180 app to record videos



1. Choose video mode:
 - Tap the Mode switch button to choose video mode.
 - Start the VR180 app, tap > **VIDEO**.
2. Focus the lens on the object to be recorded.

3. Tap .

- When the battery charge percentage is < 10%, the camera will stop recording videos.
- Please do not turn the camera off or remove the microSD card immediately after finishing recording.

Live



Before using the live function, please log in your Google account and complete the settings according to the interface prompts.

1. Start the VR180 app, tap  > **LIVE**.
2. Focus the lens on the object to be live broadcast.
3. Tap .

Viewing 2D photos / videos

1. Start the VR180 app
2. Tap **VIEW ALL**.
3. Choose the photos / videos to be viewed.

Downloading photos / videos to a mobile device

1. Start the VR180 app
2. Tap **VIEW ALL**.
3. You can download photos / videos in the following ways.
 - Tap on the photos / videos to be downloaded, tap .
 - Tap  > **Select...**, choose the photos / videos to be downloaded, tap .

Sharing photos / videos

1. Start the VR180 app.
 2. Tap on the photos / videos to be shared.
 3. Tap , complete the sharing by following the screen prompts.
- Only the photos / videos saved in the mobile device can be shared.

Deleting photos / videos

1. Start the VR180 app
2. Tap **VIEW ALL**.
3. You can delete photos / videos in the following ways.
 - Tap the thumbnails of the photos / videos to be deleted, then tap **Delete**.
 - Press and hold the thumbnails of the photos / videos to be deleted, then tap .

Connecting the camera to a computer

Connect the camera to a computer with a USB cable. You can transfer files between the camera and the computer.



Viewing 3D photos / videos using a VR device

You can view 3D photos / videos using a VR device (such as a Mirage Solo with Daydream).

- View using a Mirage Solo with Daydream
 - Save the photos / videos in the microSD card, then insert the micro SD card into the VR device.
- View by other VR devices
 - Upload the photos / videos to social media, then open them in the VR device to view them.
 - Copy the photos / videos to Google Photo, then open them in the VR device to view them.
-  Please refer to the user manual for the VR device for detailed operating steps.
- Please visit xxxxxxxx to see the supported VR devices.

Settings

Managing your camera

1. Tap the VR180 app.

2. Tap  > **Settings** > **Camera**.

Factory reset

Factory reset will delete all the personal data in the camera, including photos, videos, and VR180 app settings. Before factory reset, please copy the important data in the camera to external storage.

1. Start the VR180 app.
2. Tap  > **Settings** > **Camera** > **Factory reset camera** > **RESET**.

Rename the camera

1. Start the VR180 app.
2. Tap  > **Settings** > **Camera** > **Camera name**.
3. Type in the new name, then tap **DONE**.

Precautions for camera use

- When using the camera, please turn on the Wi-Fi on the mobile device where the VR180 app is installed to enjoy a better experience.
- When carrying the camera, please use the protective lens bag to avoid scratching the lens, resulting in unclear images.
- Avoid any heavy pressure on the lens which can damage it.
- Please use camera in a well-lit area to avoid poor results due to insufficient light.
- Keep the camera is in the stable position when shooting. We recommend using stabilizer to assist shooting if mobile shooting is required.

Appendix

Important safety and handling information

To avoid personal injury, property damage, or accidental damage to the product, read all of the information in this section before using the product. For additional tips to help you operate your device safely, go to <http://www.lenovo.com/safety>.

Handle your device with care

Do not drop, bend, or puncture your device; do not insert foreign objects into or place heavy objects on your device. Sensitive components inside might become damaged. When using your device, keep it away from hot or high-voltage environments, such as electrical appliances, electrical heating equipment, or electrical cooking equipment. Use your device only in the temperature range of 0°C (32°F) to 40°C (104°F) (storage -20°C (-4°F) to 60°C (140°F)) to avoid damage.

Don't expose your device to water, rain, extreme humidity, sweat or other liquids.

Do not disassemble or modify your device

Your device is a sealed unit. There are no end-user serviceable parts inside. All internal repairs must be done by a Lenovo-authorized repair facility or a Lenovo-authorized technician. Attempting to open or modify your device will void the warranty.

Rechargeable battery notice

CAUTION: Risk of explosion if the battery is replaced with an incorrect type.

When replacing the lithium battery, use only the same or an equivalent type that is recommended by the manufacturer. The battery contains lithium and can explode if not properly used, handled, or disposed of.

Dispose of used batteries according to the instructions.

Do not:

Throw or immerse into water.

Repair or disassemble.

Heat to more than 100°C (212°F)

Plastic bag notice

DANGER:

Plastic bags can be dangerous. Keep plastic bags away from babies and children to avoid danger of suffocation.

Adapter information

- **Prevent your device and AC adapter from getting wet.**

Do not immerse your device in water or leave your device in a location where it can come into contact with water or other liquids.

- **Use approved charging methods only.**

Note: Please only use standard Lenovo power adapters. The use of third-party power adapters will affect the charging speed, resulting in abnormal charging and potential damage to the equipment.

- Connect a standard power adapter to a suitable power outlet.
- Use a standard data cable to connect the device to a PC or a device that complies with USB 2.0 or higher.

Charging devices might become warm during normal use. Ensure that you have adequate ventilation around the charging device. Unplug the charging device if any of the following occurs:

- The charging device has been exposed to rain, liquid, or excessive moisture.
- The charging device shows signs of physical damage.
- You want to clean the charging device.

Warning:

Lenovo is not responsible for the performance or safety of products not manufactured or approved by Lenovo. Use only approved Lenovo ac adapters and batteries.

Take care when using your device in a motor vehicle or on a bicycle

Always prioritize your safety and the safety of others. Follow the law. Local laws and regulations might govern how you can use mobile electronic devices, such as your device, while you drive a motor vehicle or ride a bicycle.

Dispose according to local laws and regulations

When your device reaches the end of its useful life, do not crush, incinerate, immerse in water, or dispose of your device in any manner contrary to local laws and regulations. Some internal parts contain substances that can explode, leak, or have an adverse environmental effects if disposed of incorrectly.

See “Recycling and environmental information” for additional information.

Keep your device and accessories away from small children

Your device contains small parts that can be a choking hazard to small children. Additionally, the glass screen can break or crack if dropped on or thrown against a hard surface.

Protect your data and software

Do not delete unknown files or change the name of files or directories that were not created by you; otherwise, your device software might fail to work.

Be aware that accessing network resources can leave your device vulnerable to computer viruses, hackers, spyware, and other malicious activities that might damage your device, software, or data. It is your responsibility to ensure that you have adequate protection in the form of firewalls, antivirus software, and anti-spyware software and keep such software up to date.

Keep electrical appliances away from your device. These include electric fans, radios, high-powered speakers, air-conditioners, and microwave ovens. The strong magnetic fields generated by electrical appliances can damage the screen and the data on the device.

Be aware of heat generated by your device

When your device is turned on or the battery is charging, some parts might become hot. The temperature that they reach depends on the amount of system activity and the battery charge level. Extended contact with your body, even through clothing, could cause discomfort or even a skin burn. Avoid keeping your hands, your lap, or any other part of your body in contact with a hot section of the device for any extended time.

Electronic emission notices

FCC Compliance Statement

This equipment has been tested and found to comply with the limits for a Class B digital device, pursuant to Part 15 of the FCC Rules. These limits are designed to provide reasonable protection against harmful interference in a residential installation. This equipment generates, uses, and can radiate radio frequency energy and, if not installed and used in accordance with the instructions, may cause harmful interference to radio communications. However, there is no guarantee that interference will not occur in a particular installation. If this equipment does cause harmful interference to radio or television reception, which can be determined by turning the equipment off and on, the user is encouraged to try to correct the interference by one or more of the following measures:

- Reorient or relocate the receiving antenna.
- Increase the separation between the equipment and receiver.
- Connect the equipment into an outlet on a circuit different from that to which the receiver is connected.
- Consult an authorized dealer or service representative for help.

Lenovo is not responsible for any radio or television interference caused by unauthorized changes or modifications to this equipment. Unauthorized changes or modifications could void the user's authority to operate the equipment.

This device complies with Part 15 of the FCC Rules. Operation is subject to the following two conditions: (1) this device may not cause harmful interference, and (2) this device must accept any interference received, including interference that may cause undesired operation.

Responsible Party:

Lenovo (United States) Incorporated

1009 Think Place - Building One

Morrisville, NC 27560

Telephone: 1-919-294-5900



ISED Caution

This device complies with Innovation, Science and Economic Development Canada license-exempt RSS standard(s). Operation is subject to the following two conditions:

- (1) This device may not cause interference, and
- (2) this device must accept any interference, including interference that may cause undesired operation of the device.

Le présent appareil est conforme aux CNR d'Industrie Canada applicables aux appareils radio exempts de licence. L'exploitation est autorisée aux deux conditions suivantes:

- (1) l'appareil ne doit pas produire de brouillage, et
- (2) l'utilisateur de l'appareil doit accepter tout brouillage radioélectrique subi, même si le brouillage est susceptible d'en compromettre le fonctionnement.

Japanese VCCI Class B statement

この装置は、クラス B 情報技術装置です。この装置は、家庭環境で使用することを目的としていますが、この装置がラジオやテレビジョン受信機に近接して使用されると、受信障害を引き起こすことがあります。取扱説明書に従って正しい取り扱いをして下さい。VCCI-B

Japan compliance statement for products that connect to power mains rated at less than or equal to 20A per phase

日本の定格電流が 20A/相 以下の機器に対する高調波電流規制

高調波電流規格 JIS C 61000-3-2 適合品

Environmental, recycling, and disposal information

General recycling statement

Lenovo encourages owners of information technology (IT) equipment to responsibly recycle their equipment when it is no longer needed. Lenovo offers a variety of programs and services to assist equipment owners in recycling their IT products. For information on recycling Lenovo products, go to <http://www.lenovo.com/recycling>.

Important battery and WEEE information



Batteries and electrical and electronic equipment marked with the symbol of a crossed-out wheeled bin may not be disposed as unsorted municipal waste. Batteries and waste of electrical and electronic equipment (WEEE) shall be treated separately using the collection framework available to customers for the return, recycling, and treatment of batteries and WEEE. When possible, remove and isolate batteries from WEEE prior to placing WEEE in the waste collection stream. Batteries are to be collected separately using the framework available for the return, recycling, and treatment of batteries and accumulators.

Country-specific information is available at <http://www.lenovo.com/recycling>.

Recycling information for Japan

Recycling and disposal information for Japan is available at <http://www.lenovo.com/recycling/japan>.

Recycling information for India

Recycling and disposal information for India is available at

http://www.lenovo.com/social_responsibility/us/en/sustainability/ptb_india.html.

Battery recycling marks

- The battery recycling information of Taiwan



- Battery recycling information for the United States and Canada



US & Canada Only

- Battery recycling information for the European Union

EU



Export classification notice

This product is subject to the United States Export Administration Regulations (EAR) and has an Export Classification Control Number (ECCN) of 5A992.c. It can be re-exported except to any of the embargoed countries in the EAR E1 country list.