



# BG-C19

## BATTERY GRIP

Designed for the  
Canon EOS R  
Mirrorless Camera

 VELLO®

USER'S MANUAL

# Thank you for choosing Vello

The Vello BG-C19 battery grip offers extended shooting time and comfort when shooting in a vertical (portrait) orientation. This grip is compatible with the Canon EOS R mirrorless camera and accepts up to two Canon LP-E6N/LP-E6NH rechargeable batteries. Use the included USB-C™ power adapter to charge the batteries in the grip without removing them. The grip provides an alternate shutter release button, main and quick-control dials, control lock switch, AF start button, AE/FE lock button, and AF point/magnify button, making the grip ideal for shooting portrait photography. The control lock switch disables all the grip's controls to prevent unwanted triggering.

*Please read through this entire manual before using the BG-C19 battery grip.*



# Precautions

- 1.** The BG-C19 should be used only with the compatible devices specified in this manual.
- 2.** Use only with the batteries and battery holders recommended in this manual.
- 3.** If you notice smoke, noise, or an unusual smell from the battery pack, discontinue use immediately. Remove the batteries, and take the device to a Vello authorized reseller.
- 4.** The battery level may not display properly if batteries are installed before mounting the grip.
- 5.** Remove batteries from the grip when not in use.
- 6.** Do not attempt to disassemble.
- 7.** Avoid exposing this product to water or extreme humidity, and keep it in a cool, dry place.
- 8.** Keep out of reach of children.
- 9.** All images are for illustrative purposes only.

# Overview

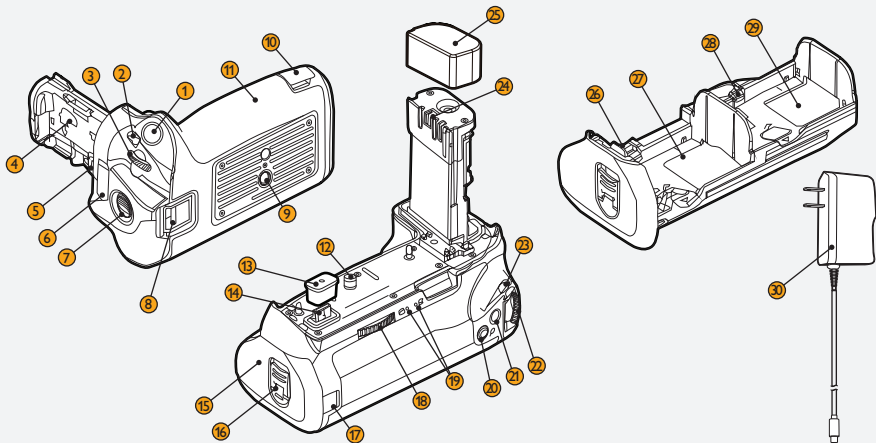

- ① Shutter release button
- ② Multi-function button
- ③ Main dial
- ④ Camera battery door holder
- ⑤ Camera contact cover holder
- ⑥ USB-C port
- ⑦ Control lock switch
- ⑧ Hand-strap mount
- ⑨ Tripod socket
- ⑩ PC terminal port

- ⑪ Nonslip grip
- ⑫ Mounting screw
- ⑬ Contact cap
- ⑭ Contacts
- ⑮ Battery compartment
- ⑯ Battery compartment lock
- ⑰ DC coupler cord hole
- ⑱ Thumbwheel
- ⑲ Charge indicator LEDs
- ⑳ AF point / index / reduce button

- ㉑ AE lock / FE lock button
- ㉒ Quick-control dial
- ㉓ AF-ON / AF start button
- ㉔ Power contacts
- ㉕ Power contact cap
- ㉖ Slot 1 lock release
- ㉗ Battery slot 1
- ㉘ Slot 2 lock release
- ㉙ Battery slot 2
- ㉚ USB-C power adapter

# Attaching the Battery Grip

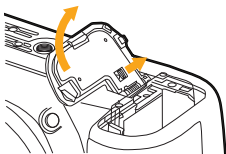

1. Ensure that the camera is turned off, and remove the camera's battery chamber door. Press the door's latch release and pull gently until the door detaches.

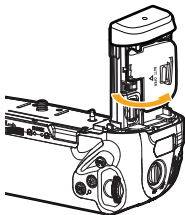

2. Insert the chamber door into the BG-C19's camera battery door holder, and push down so it clicks in place.

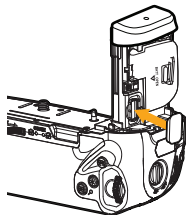

3. Remove the camera's contact cover, and place it in the grip's camera contact cover holder.

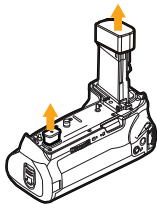

- 4.** Remove the grip's two contact caps.

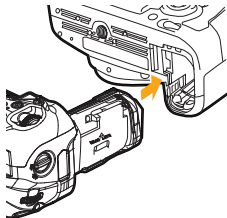

- 5.** Insert the battery grip's power contacts into the camera's battery chamber and attach the grip to the camera.

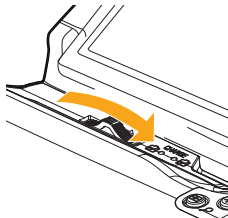

- 6.** Rotate the thumbwheel in the direction of the arrow until the grip is secured to the camera.

# Inserting the Batteries

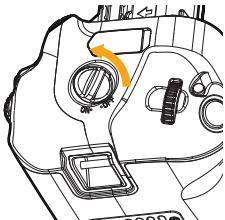

1. Turn off the camera's power, and make sure the grip's control lock switch is in the Off position.

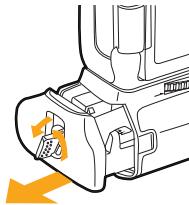

2. Twist the battery tray's lock and remove the battery tray from the grip.

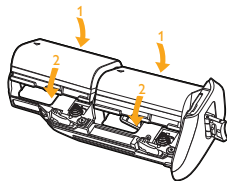

3. Insert one or both batteries as shown, and push down to lock in place.

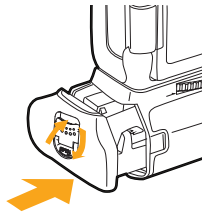

4. Insert and lock the battery tray inside the battery grip.

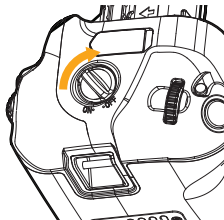

5. Turn on the camera power, and switch the grip's control lock to the On position.

*Note: When removing the grip, turn off the camera's power, switch the grip's control lock to off, and then remove the batteries.*

# Removing the Batteries

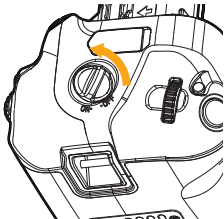

- 1.** Turn off the camera's power, and make sure the grip's control lock switch is in the Off position.

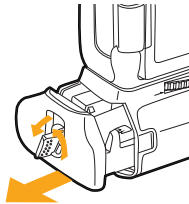

- 2.** Twist the battery tray's lock and remove the battery tray from the grip.

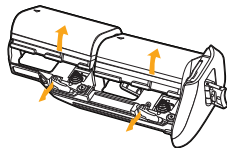

- 3.** Pull the lock release for battery slot 1 or 2 to remove.

# In-Grip Battery Charging

You can charge the batteries inside the grip, without removing them, using the included 5 V / 2.4 A power adapter. Make sure you turn off the camera to begin charging. Then use the included power adapter to connect the battery grip's USB-C port to an AC outlet.

The charging indicator LEDs will glow green when charging, and turn off when fully charged. If there are two batteries in the grip, slot 1 will charge first.

## Specifications

<b>Power source</b>	Up to two Canon LP-E6N/LP-E6NH type rechargeable Li-ion batteries Canon AC Adapter AC-E6N and DR-E6 DC Coupler
<b>USB port</b>	USB-C
<b>USB input</b>	5 V / 2.4 A
<b>Operating temperature</b>	32°F to 104°F (0°C to 40°C)
<b>Dimensions (H × W × D)</b>	1.9 × 5.7 × 3.2 in. (4.9 × 14.4 × 8.1 cm)
<b>Weight</b>	10.2 oz. (290 g) without batteries

Specifications and design are subject to change without notice.

# ONE-YEAR LIMITED WARRANTY

This VELLO product is warranted to the original purchaser to be free from defects in materials and workmanship under normal consumer use for a period of one (1) year from the original purchase date or thirty (30) days after replacement, whichever occurs later. The warranty provider's responsibility with respect to this limited warranty shall be limited solely to repair or replacement, at the provider's discretion, of any product that fails during normal use of this product in its intended manner and in its intended environment. Inoperability of the product or part(s) shall be determined by the warranty provider. If the product has been discontinued, the warranty provider reserves the right to replace it with a model of equivalent quality and function.

This warranty does not cover damage or defect caused by misuse, neglect, accident, alteration, abuse, improper installation or maintenance. EXCEPT AS PROVIDED HEREIN, THE WARRANTY PROVIDER MAKES NEITHER ANY EXPRESS WARRANTIES NOR ANY IMPLIED WARRANTIES, INCLUDING BUT NOT LIMITED TO ANY IMPLIED WARRANTY OF MERCHANTABILITY OR FITNESS FOR A PARTICULAR PURPOSE. This warranty provides you with specific legal rights, and you may also have additional rights that vary from state to state.

To obtain warranty coverage, contact the Vello Customer Service Department to obtain a return merchandise authorization ("RMA") number, and return the defective product to Vello along with the RMA number and proof of purchase. Shipment of the defective product is at the purchaser's own risk and expense.

For more information or to arrange service, visit [www.vellogear.com](http://www.vellogear.com) or call Customer Service at 212-594-2353.

Product warranty provided by the Gradus Group.

[www.gradusgroup.com](http://www.gradusgroup.com)

VELLO is a registered trademark of the Gradus Group. © 2020 Gradus Group LLC. All Rights Reserved.



[www.vellogear.com](http://www.vellogear.com)

All other trademarks are the property of their respective owners.

GG1