

ViewSonic®



VFD1028w
Digital Photo Frame
User Guide

Model No. VS14962

Compliance Information

FCC Statement

This device complies with part 15 of FCC Rules. Operation is subject to the following two conditions: (1) this device may not cause harmful interference, and (2) this device must accept any interference received, including interference that may cause undesired operation.

This equipment has been tested and found to comply with the limits for a Class B digital device, pursuant to part 15 of the FCC Rules. These limits are designed to provide reasonable protection against harmful interference in a residential installation. This equipment generates, uses, and can radiate radio frequency energy, and if not installed and used in accordance with the instructions, may cause harmful interference to radio communications. However, there is no guarantee that interference will not occur in a particular installation. If this equipment does cause harmful interference to radio or television reception, which can be determined by turning the equipment off and on, the user is encouraged to try to correct the interference by one or more of the following measures:

- Reorient or relocate the receiving antenna.
- Increase the separation between the equipment and receiver.
- Connect the equipment into an outlet on a circuit different from that to which the receiver is connected.
- Consult the dealer or an experienced radio/TV technician for help.

Warning: You are cautioned that changes or modifications not expressly approved by the party responsible for compliance could void your authority to operate the equipment.

For Canada

- This Class B digital apparatus complies with Canadian ICES-003.
- Cet appareil numérique de la classe B est conforme à la norme NMB-003 du Canada.

CE Conformity for European Countries



The device complies with the EMC Directive 2004/108/EC and Low Voltage Directive 2006/95/EC.

Following information is only for EU-member states:

The mark is in compliance with the Waste Electrical and Electronic Equipment Directive 2002/96/EC (WEEE).

The mark indicates the requirement NOT to dispose the equipment including any spent or discarded batteries or accumulators as unsorted municipal waste, but use the return and collection systems available.



If the batteries, accumulators and button cells included with this equipment, display the chemical symbol Hg, Cd, or Pb, then it means that the battery has a heavy metal content of more than 0.0005% Mercury or more than, 0.002% Cadmium, or more than 0.004% Lead.



Declaration of RoHS Compliance

This product has been designed and manufactured in compliance with Directive 2002/95/EC of the European Parliament and the Council on restriction of the use of certain hazardous substances in electrical and electronic equipment (RoHS Directive) and is deemed to comply with the maximum concentration values issued by the European Technical Adaptation Committee (TAC) as shown below:

Substance	Proposed Maximum Concentration	Actual Concentration
Lead (Pb)	0.1%	< 0.1%
Mercury (Hg)	0.1%	< 0.1%
Cadmium (Cd)	0.01%	< 0.01%
Hexavalent Chromium (Cr ⁶⁺)	0.1%	< 0.1%
Polybrominated biphenyls (PBB)	0.1%	< 0.1%
Polybrominated diphenyl ethers (PBDE)	0.1%	< 0.1%

Certain components of products as stated above are exempted under the Annex of the RoHS Directives as noted below:

Examples of exempted components are:

1. Mercury in compact fluorescent lamps not exceeding 5 mg per lamp and in other lamps not specifically mentioned in the Annex of RoHS Directive.
2. Lead in glass of cathode ray tubes, electronic components, fluorescent tubes, and electronic ceramic parts (e.g. piezoelectronic devices).
3. Lead in high temperature type solders (i.e. lead-based alloys containing 85% by weight or more lead).
4. Lead as an alloying element in steel containing up to 0.35% lead by weight, aluminium containing up to 0.4% lead by weight and as a copper alloy containing up to 4% lead by weight.

Copyright Information

Copyright© ViewSonic Corporation, 2012. All rights reserved.

ViewSonic, the three birds logo, OnView, ViewMatch, and ViewMeter are registered trademarks of ViewSonic Corporation.

Disclaimer: ViewSonic Corporation shall not be liable for technical or editorial errors or omissions contained herein; nor for incidental or consequential damages resulting from furnishing this material, or the performance or use of this product.

In the interest of continuing product improvement, ViewSonic Corporation reserves the right to change product specifications without notice. Information in this document may change without notice.

No part of this document may be copied, reproduced, or transmitted by any means, for any purpose without prior written permission from ViewSonic Corporation.

For Your Records

Product Name:	VFD1028w ViewSonic Digital Photo Frame
Model Number:	VS14962
Document Number:	VFD1028w_UG_ENG Rev. 1A 09-04-12
Serial Number:	_____
Purchase Date:	_____

Product disposal at end of product life

ViewSonic respects the environment and is committed to working and living green. Thank you for being part of Smarter, Greener Computing. Please visit ViewSonic website to learn more.

USA & Canada: <http://www.viewsonic.com/company/green/recycle-program/>

Europe: <http://www.viewsoniceurope.com/uk/support/recycling-information/>

Taiwan: <http://recycle.epa.gov.tw/recycle/index2.aspx>

Important Safety Precautions

Always follow these basic safety precautions when using your Digital Picture Frame. This will reduce the risk of fire, electric shock, and injury.

Warning: To reduce the risk of fire or shock hazard, do not expose this product to rain or moisture.

Warning: To prevent the risk of electric shock, do not remove the cover. There are no user-serviceable parts inside. Refer all servicing to qualified personnel.

- The Digital Picture Frame is for indoor use only.
- Unplug the Digital Picture Frame before performing care and maintenance.
- Do not block the ventilation holes on the back of the Digital Picture Frame at any time.
- Keep your Digital Picture Frame out of direct sunlight and heat sources.
- Protect the power cord. Route power cord so that it is not likely to be walked on or pinched by item places on or against it. Pay particular attention to the point where the cord attaches to the Digital Picture Frame.
- Only use the AC adapter included with the Digital Picture Frame. Using any other power adapter will void your warranty.
- Unplug the power cord from the outlet when the unit is not in use.
- Risk of explosion if battery replaced by an incorrect type. Dispose of used batteries according to the instructions.

Cleaning the LCD Screen

Touch the screen gently.

To clean fingerprints or dust from the LCD screen, it is recommended to use a soft, non-abrasive cloth such as a camera lens cloth to clean the LCD screen.

If you use a commercial LCD cleaning kit, do not apply the cleaning liquid directly to the LCD screen. Clean the LCD screen with a cleaning cloth moistened with the liquid.

Cleaning the Digital Picture Frame

Clean the outer surface of the Digital Picture Frame (excluding the screen) with a soft cloth dampened with water.

Package Content

- Digital Picture Frame
- Power Adapter
- Stand
- Remote Control
- USB Cable
- Quick Start Guide
- User's Manual

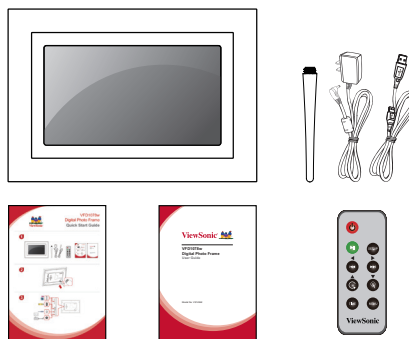

Table of Contents

1. Hardware	1
1.1. Specifications	1
1.2. Identification of Controls	1
1.3. Accessories	2
1.4. Features	2
1.5. Features Checklist	3
1.6. Remote control	3
2. Main function	4
2.1. Photo	5
2.1.1. Browse	6
2.1.2. Slideshow	6
2.2. Calendar	7
2.2.1. Display Mode	7
2.2.1.1. Monthly calendar	7
2.2.1.2. Calendar	8
2.2.1.3. Clock	8
2.3. Settings	9
2.3.1. Photo Setting	10
2.3.2. Calendar Setting	10
2.3.3. System Setting	11
3. Troubleshooting	12
Customer Support	13
Limited Warranty	14

1. Hardware

1.1. Specifications

LCD screen	Panel size/ Aspect ratio	10.1 inch/ Wide	
	Effective viewing area	8.2" W x 4.1" H (208.3 mm x 104.1 mm)	
	Resolution	1024 x 600 pixels	
Photo File	Image formats supported	JPG, JPEG (baseline coding), BMP	
	Max. image resolution	30 million pixels	
Calendar		Clock, Calendar	
Memory Medium	Internal	128 MB	
	Memory Card	MMC, SD, SDHC (max. 32GB)	
	USB	USB flash drive	
	File System	FAT, FAT32	
Electric Specification	Power Input	5VDC, 1A	
	Power Consumption	≤ 5W	
	Power Adapter	Input	AC 100-240V, 50/60HZ
		Output	DC5V, 1A
Dimensions	Dimensions	12.52"W x 8.7"H x 1.42"D (318 x 221 x 36 mm)	
	Weight	Approx. 2.03 lbs (917g)	
	Operating Mode	Buttons on panel and IR Remote	
Environmental Requirements	Operating temperature	0°C ~ 40°C (32°F~104°F)	
	Storage temperature	-20°C ~ 60°C (-4°F~140°F)	

1.2. Identification of Controls

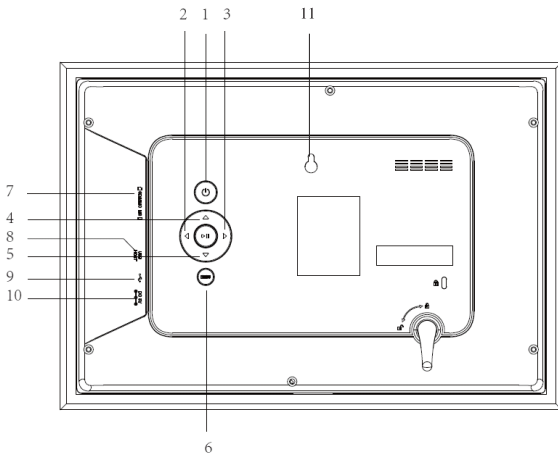

1. Power on/off
2. Right
3. Left
4. UP
5. DOWN
6. MENU
7. MMC/SD/MS
8. USB HOST
9. MINI USB
10. DC IN
11. Wall mount hole

1.3. Accessories

The following accessories are included with the digital photo frame.



Remote Control



AC/DC Adapter



USB Cable



Stand

1.4. Features

- Remote control and hard keypad control.
- Playback of photo stored on data storage devices through High-Speed USB 2.0 port, card-reader port or the built-in memory.
- Data storage devices: USB disk, SD, MS, MMC card.
- Multi-language OSD supports: English, French, Spanish.
- File format: JPG, BMP.
- Photo Play Sequence: sequence, random.
- Automatic slideshow with multiple transition effects and adjustable display time.
- Supports calendar.
- Has screen saver function.
- 10.1 inch TFT LCD display, brightness, contrast and saturation adjustable.
- Add and delete image on built-in memory.

1.5. Features Checklist

	VFD1028w
Remote control and keypad control	√
SD/MS/MMC	√
USB	√
Photo	√
10.1" TFT-LCD display	√
Built-in memory	√
Calendar	√

1.6. Remote control

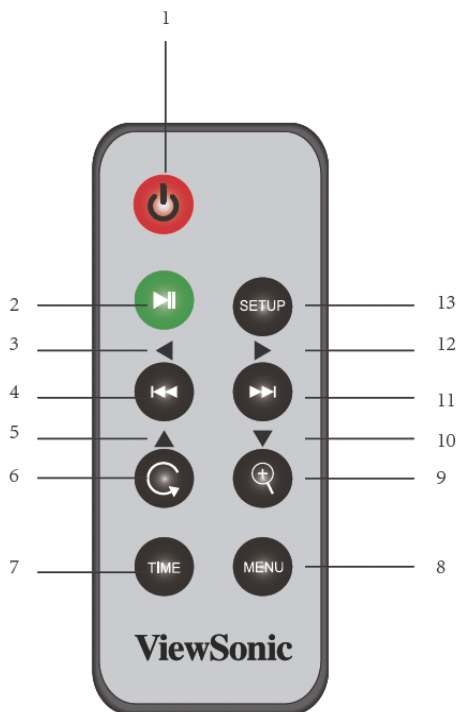

- 1: Power on/off
- 2: Play/Pause/Enter
- 3/4: Left/Backward
- 5/6: Up/Return
- 7: Time
- 8: Menu
- 9/10: Zoom/Down
- 11/12: Forward/Right
- 13: Setup menu

2. Main function

To attach the stand, screw in the stand clockwise until it is secure.

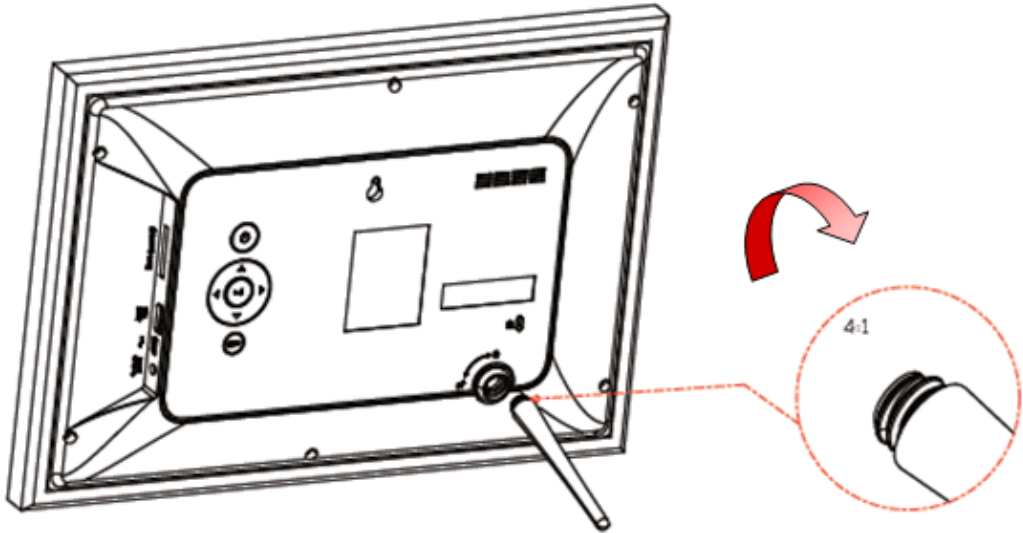

Insert an SD/SDHC/MMC or USB memory source device into an appropriate memory slot. Connect the supplied power adapter to the photo frame and to an electrical outlet.

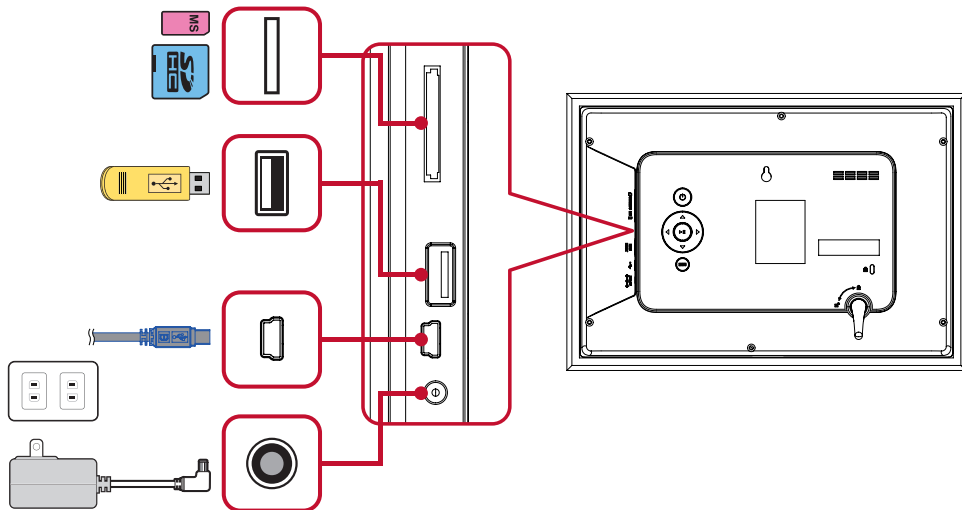

The photo frame will power on automatically. Press “  ” to power on and off manually.

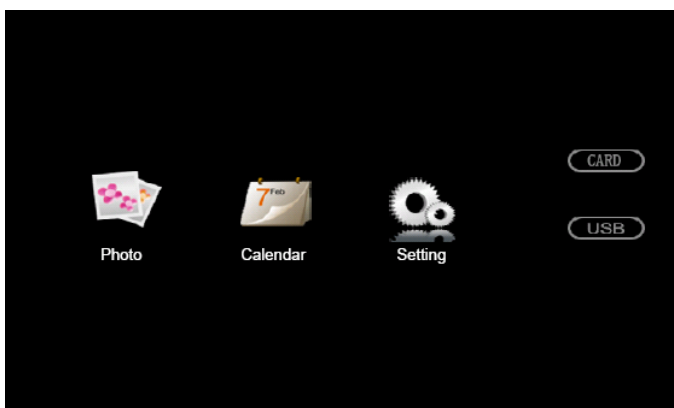

On the Main Menu, there are **【Photo】** **【Calendar】** **【Setting】** .

This photo frame searches the memory source device after power on and playback photos in slideshow mode if there are photos found. If there is no photo found, the Main Menu will be shown.





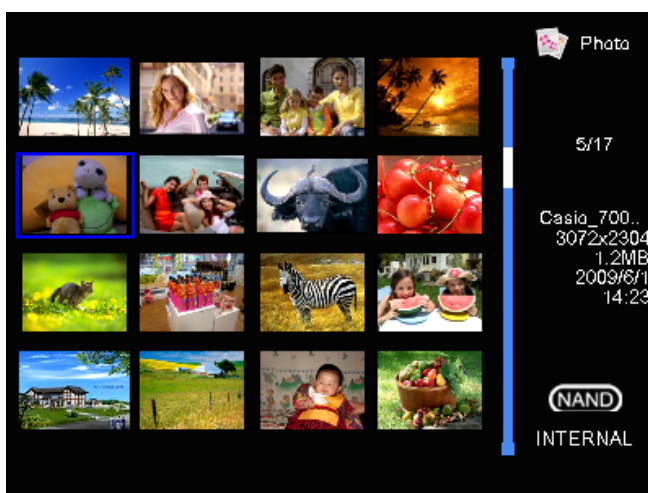

2.1. Photo

Insert a memory card or USB flash drive with the photo on it into the photo frame if you had not done so. Select **【Photo】** from the main menu, press the **ENTER** button, this photo frame will start slideshow automatically. Press **MENU** to display photos in a thumbnail view.









The following button functions are available while viewing photos in thumbnail and slideshow modes.

2.1.1. Browse

Buttons	Functional descriptions
	Exit to thumbnail view
	Previous photo
	Next photo
	--
	--
	Toggle Browse and Slideshow modes

2.1.2. Slideshow

Buttons	Functional descriptions
	Exit to thumbnail view
	Previous photo
	Next photo
	--
	--
	Toggle Browse and Slideshow modes

2.2. Calendar

Select **Calendar** from the main menu, press the **ENTER** button to view the calendar. Monthly calendar mode is the default.





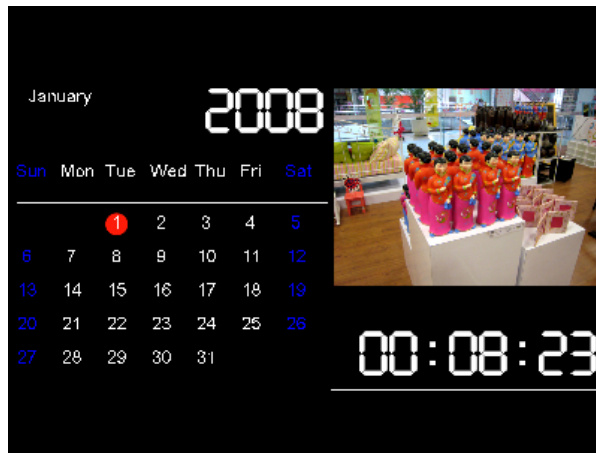

2.2.1. Display Mode

The date and time displayed on the calendar are the current date and time set in the system.



2.2.1.1 Monthly calendar





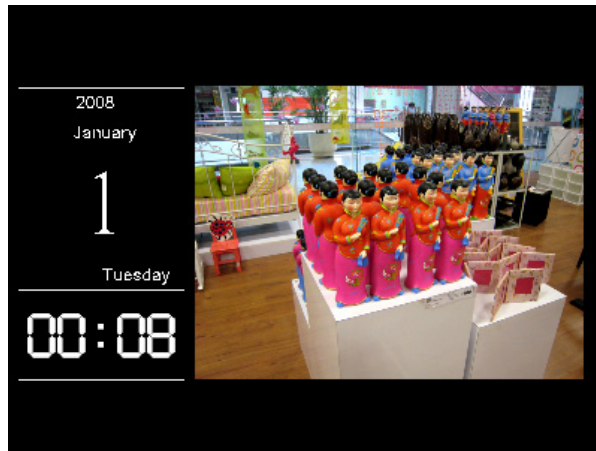

In this mode, photos are shown in slideshow on the top right.

Buttons	Functional descriptions
	Exit to the main menu
	Previous photo
	Next photo
	Previous month
	Next month
	Toggle Monthly calendar, Calendar (day), and Clock viewing modes

2.2.1.2 Calendar

In this mode, photos are shown in slideshow on the right.









Buttons	Functional descriptions
	Exit to the main menu
	Previous photo
	Next photo
	--
	--
	Toggle Monthly calendar, Calendar (day), and Clock viewing modes

2.2.1.3 Clock

In this mode, an analog clock is shown in the center.







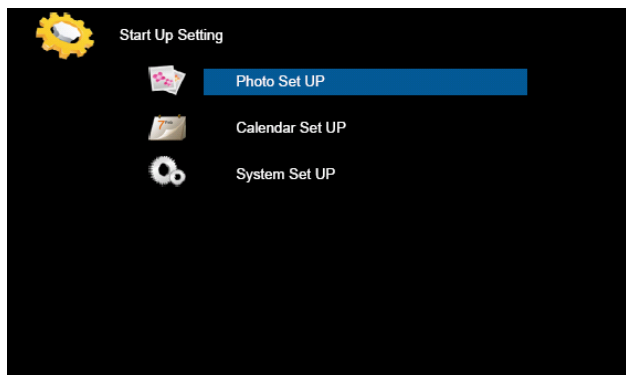

Buttons	Functional descriptions
	Exit to the main menu
	
	
	--
	--
	Toggle Monthly calendar, Calendar (day), and Clock viewing modes

2.3. Settings

Select **【Setup】** from the main menu, press the “**ENTER**” button or press the **【SETUP】** button on the remote control to enter the Settings Menu. The Photo, Calendar, and System settings are shown below.



Press the Up **【▲】** or Down **【▼】** button to highlight a setting category, then **【ENTER】** button to enter the setup submenu.

Buttons	Functional descriptions
	Exit to Main Setting Menu
	Decrease the setting value
	Increase the setting value
	Move down or to the previous menu entry field
	Move up or to the next menu entry field
	Enter the setup submenu

2.3.1. Photo Setting

Press the Up [▲] or Down [▼] button to highlight Photo Setting, then [ENTER] button to enter the setup submenu. Press the Left [◀] or Right [▶] button to change the entry field. Press the Up [▲] or Down [▼] button to move between entry fields.

Photo Setting Options	Functional descriptions
Display Mode	Photo startup modes: Slideshow, Thumbnail, or Browse Mode
Display Ratio	Set the display scaling: Fit to Screen, Crop to Fill, or Full Screen
Slideshow Duration	Set the duration time for slideshow: 5sec, 15 sec, 30 sec, 60 sec, 5 min, or 15 min
Slideshow Repeat	Repeat modes: Repeat (on) or Once (off)
Slideshow Effect	Set the slide transition effects: Random, S-Curve, Partition, Erase, Blind, Random line, Grid, Cross, Spiral, Rectangle, or Close
PhotoFrom	Source settings: Current Directory or All Directories
Photo Play Sequence	Set playback modes: Sequential Order or Random

2.3.2. Calendar Setting

Press the Up [▲] or Down [▼] button to highlight Calendar Setting, then [ENTER] button to enter the setup submenu. Press the Left [◀] or Right [▶] button to change the entry field. Press the Up [▲] or Down [▼] button to move between entry fields.

Calendar Setting Options	Functional descriptions
Display Mode	Set the calendar display modes: Monthly Calendar, Calendar (day), or Clock
Date	Set the current date
Clock Mode	Set the clock display formats: 12 Hour or 24 Hour
Clock Time	Set the current time

2.3.3. System Setting

Press the Up [▲] or Down [▼] button to highlight System Setting, then [ENTER] button to enter the setup submenu. Press the Left [◀] or Right [▶] button to change the entry field. Press the Up [▲] or Down [▼] button to move between entry fields.

Photo Setting Options	Functional descriptions
Language	Set the display language
Brightness	Adjust screen brightness: 1 to 16
Contrast	Adjust the screen contrast: 1 to 16
Saturation	Adjust the screen saturation: contrast: 1 to 16
Auto Power On	Off is disable and On is enable
Auto Boot-Up Time	Set the time for the unit to power on automatically
Auto Power Off	Off is disable and On is enable
Auto Shutdown Time	Set the time for the unit to power off automatically
Auto-Power Frequency	How often you want the unit to use the timer after the timer is enable. Available options are: Everyday, Weekday, Weekend, and Once.
Reset default setting	Restore the factory default settings
Version	Displays version information
System	For firmware upgrade

3. Troubleshooting

Symptoms	Solutions
Cannot power on, even when the device is connected to an electrical outlet.	<ul style="list-style-type: none">• Check whether the AC power adapter rating is correct, and it is securely plugged to the device and to an electrical outlet.
Failed to read memory card	<ul style="list-style-type: none">• Check whether memory card is inserted properly. The notch should match the label on the device. Do not force the memory card in
Cannot playback pictures	<ul style="list-style-type: none">• The digital photo frame only supports pictures in JPEG, JPG format in baseline and BMP.
Screen is off or too dark	<ul style="list-style-type: none">• Check whether the screen brightness is set to a low level in the Setup menu.

Customer Support

For technical support or product service, see the table below or contact your reseller.

Note: You will need the product serial number.

Country/ Region	Web Site	T=Telephone F=Fax	E-mail
Australia/New Zealand	www.viewsonic.com.au	AUS=1800 880 818 NZ=0800 008 822	service@au.viewsonic.com
Canada	www.viewsonic.com	T (Toll-Free)= 1-866-463-4775 T (Toll)= 1-424-233-2533 F= 1-909-468-3757	service.ca@viewsonic.com
Europe	www.viewsoniceurope.com	www.viewsoniceurope.com/uk/Support/Calldesk.htm	
Hong Kong	www.hk.viewsonic.com	T= 852 3102 2900	service@hk.viewsonic.com
India	www.in.viewsonic.com	T= 1800 11 9999	service@in.viewsonic.com
Ireland (Eire)	www.viewsoniceurope.com/ uk/	www.viewsoniceurope.com/uk/ support/call-desk/	service_ie@viewsoniceurope.com
Korea	www.kr.viewsonic.com	T= 080 333 2131	service@kr.viewsonic.com
Latin America (Argentina)	www.viewsonic.com/la/	T= 0800-4441185	soporte@viewsonic.com
Latin America (Chile)	www.viewsonic.com/la/	T=1230-020-7975	soporte@viewsonic.com
Latin America (Columbia)	www.viewsonic.com/la/	T= 01800-9-157235	soporte@viewsonic.com
Latin America (Mexico)	www.viewsonic.com/la/	T= 001-8882328722	soporte@viewsonic.com
Renta y Datos, 29 SUR 721, COL. LA PAZ, 72160 PUEBLA, PUE. Tel: 01.222.891.55.77 CON 10 LINEAS Electroser, Av Reforma No. 403Gx39 y 41, 97000 Merida, Yucatan. Tel: 01.999.925.19.16 Other places please refer to http://www.viewsonic.com/la/soporte/index.htm#Mexico			
Latin America (Peru)	www.viewsonic.com/la/	T= 0800-54565	soporte@viewsonic.com
Macau	www.hk.viewsonic.com	T= 853 2870 0303	service@hk.viewsonic.com
Middle East	ap.viewsonic.com/me/	Contact your reseller	service@ap.viewsonic.com
Puerto Rico & Virgin Islands	www.viewsonic.com	T= 1-800-688-6688 (English) T= 1-866-379-1304 (Spanish) F= 1-909-468-3757	service.us@viewsonic.com soporte@viewsonic.com
Singapore/ Malaysia/ Thailand	www.viewsonic.com.sg	T= 65 6461 6044	service@sg.viewsonic.com
South Africa	ap.viewsonic.com/za/	Contact your reseller	service@ap.viewsonic.com
United Kingdom	www.viewsoniceurope.com/ uk/	www.viewsoniceurope.com/uk/ support/call-desk/	service_gb@ viewsoniceurope.com
United States	www.viewsonic.com	T (Toll-Free)= 1-800-688-6688 T (Toll)= 1-424-233-2530 F= 1-909-468-3757	service.us@viewsonic.com

Limited Warranty

VIEWSONIC Digital Photo Frame

What the warranty covers:

ViewSonic warrants its products to be free from defects in material and workmanship, under normal use, during the warranty period. If a product proves to be defective in material or workmanship during the warranty period, ViewSonic will, at its sole option, repair or replace the product with a like product. Replacement product or parts may include remanufactured or refurbished parts or components.

How long the warranty is effective:

ViewSonic Digital Photo Frame are warranted for 1 year for labor from the date of the first customer purchase.

Who the warranty protects:

This warranty is valid only for the first consumer purchaser.

What the warranty does not cover:

1. Any product on which the serial number has been defaced, modified or removed.
2. Damage, deterioration or malfunction resulting from:
 - a. Accident, misuse, neglect, fire, water, lightning, or other acts of nature, unauthorized product modification, or failure to follow instructions supplied with the product.
 - b. Repair or attempted repair by anyone not authorized by ViewSonic.
 - c. Causes external to the product, such as electric power fluctuations or failure.
 - d. Use of supplies or parts not meeting ViewSonic's specifications.
 - e. Normal wear and tear.
 - f. Any other cause which does not relate to a product defect.
3. Any product exhibiting a condition commonly known as "image burn-in" which results when a static image is displayed on the product for an extended period of time.

How to get service:

1. For information about receiving service under warranty, contact ViewSonic Customer Support (please refer to Customer Support page). You will need to provide your product's serial number.
2. To obtain warranted service, you will be required to provide (a) the original dated sales slip, (b) your name, (c) your address, (d) a description of the problem, and (e) the serial number of the product.
3. Take or ship the product freight prepaid in the original container to an authorized ViewSonic service center or ViewSonic.
4. For additional information or the name of the nearest ViewSonic service center, contact ViewSonic.

Limitation of implied warranties:

There are no warranties, express or implied, which extend beyond the description contained herein including the implied warranty of merchantability and fitness for a particular purpose.

Exclusion of damages:

ViewSonic's liability is limited to the cost of repair or replacement of the product. ViewSonic shall not be liable for:

1. Damage to other property caused by any defects in the product, damages based upon inconvenience, loss of use of the product, loss of time, loss of profits, loss of business opportunity, loss of goodwill, interference with business relationships, or other commercial loss, even if advised of the possibility of such damages.
2. Any other damages, whether incidental, consequential or otherwise.
3. Any claim against the customer by any other party.



ViewSonic®