

PYLE

PyleUSA.com



PT8000CH

8-Channel Home Theater Amplifier
Multi-Zone Audio Source Control,
Rack Mount Amp, 8000 Watt

User Manual

Read through this user manual before using the product to ensure its correct use. Keep this manual for future reference.

The **PT8000CH** contains the excellent performance and reliability that PYLEUSA products have been recognized for. The PT8000CH features the flexibility needed for demanding custom installation applications. It is ideal for use in home theater, stereo, multi-room, multi-zone and commercial applications.

For best performance, please carefully read the instructions in this manual.

TABLE OF CONTENTS

Features	3
Front Panel Diagram	4
Rear Panel Diagram	4
System Design & Operation Considerations	6
System Design Examples	8
Diagram 4 - Multi Room Installation	9
Diagram 5 - Multi-Zone Installation #1	10
Diagram 6 - Multi-Zone Installation #2	11
Diagram 7- Home Theater/Multi-Room Installation	12
Installation Considerations	13
Installation	14
Operation	18
Troubleshooting	19
Specifications	21

FEATURES

Audiophile Design

Sophisticated design and superior internal components result in outstanding sound quality, performance and long term reliability.

Advanced Protection

Each channel is individually protected. If the circuitry determines that a channel must be shutdown for protection, a rare occurrence, only the channel affected will be turned off. The other channels will continue to play. Once conditions return to normal, the affected channel will be turned back on and operate as normal.

Flexible Input Selection

Each of the 8 channels can be assigned a variety of source inputs. A dedicated input can be assigned to each channel. Each channel can also be configured to play common signals from the Bus or Auxiliary inputs. This provides the flexibility needed in sophisticated custom audio installations.

Bridging

The power output of adjacent channels can be combined to provide extra power when needed in certain areas. This is easily accomplished by flipping a single switch.

Individual Channel Level Adjustments

Each channel has its own level adjustment. This allows the loudness of each speaker to be perfectly matched to its area.

Multiple Power Modes and Output Trigger

There are three ways to turn the amplifier ON: constant, trigger and audio sense. This allows the amplifier to operate seamlessly as part of a sophisticated custom installation. A separate output trigger allows the amplifier to activate other components via voltage trigger.

DIAGRAM 1 - FRONT PANEL

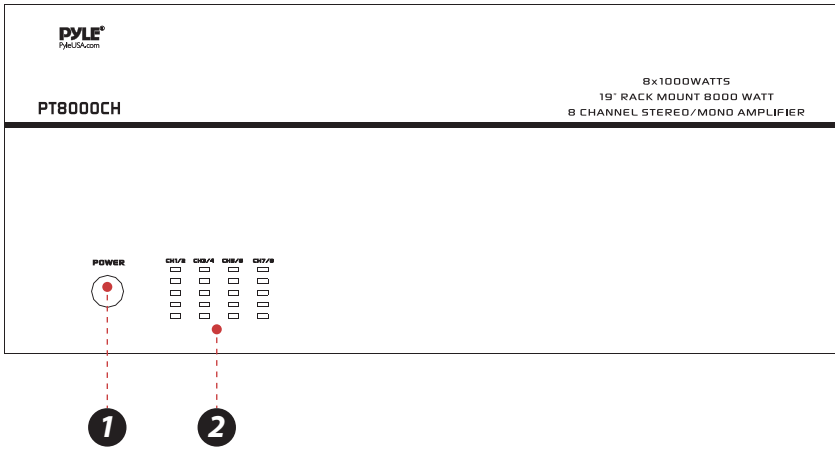

1. POWER SWITCH

Master power switch. Turns off power to amplifier and Power Mode Circuitry.

2. POWER OUTPUT LEVEL INDICATOR

This is level meter which shows outputs levels of ch 1-2 ch 3-4 ch 5-6 & ch 7-8 condition on the operation. Therefore, you can see output condition thru this master indicator.

DIAGRAM 2 - REAR PANEL

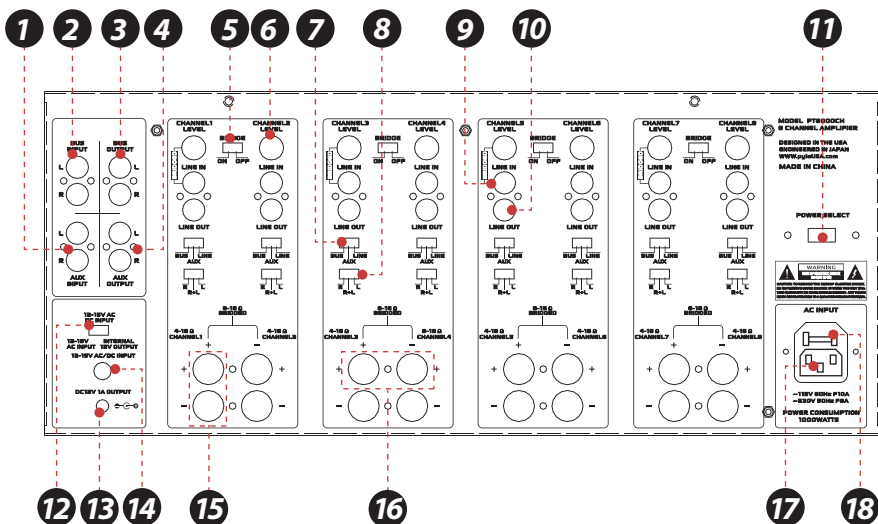

- 1-2.** Main bus inputs allow outputs from receivers, CD players, TVs, or any stereo audio sources to be amplified across all channels for easy multi-room applications. Auxiliary inputs allows an addition audio source to be played on any channel that is switched to AUX .
- 3-4.** Bus outputs allows the bus inputs to be sent to other amplifiers or a daisy chain without the need for "Y" cable splitters. Auxiliary output allows you to daisy chain the input to other audio sources.
- 5.** Bridging switch allows you to easily double the power output by coupling two channels together.
- 6.** Level controls for each channel.
- 7.** Input Selection switch allows you to select between the common bus and auxiliary inputs or the individual channel input.
- 8.** One switch allows you to select which stereo Input channel will play through the speaker outputs: left, right, or left and right combined. If switched to Left + Right, both input channels are combined.
- 9.** Gold plated individual channel inputs allow you to connect different audio sources to each channel.
- 10.** Line signal output
- 11.** Voltage Selector 110-220V
- 12.** The Power Mode switch is used to toggle between three different trigger methods to power up the amplifier.
- 13.** 12V output to turn on other devices when amplifier is powered up.
Connect to projector screens, powered drapes, or other devices with voltage triggers.
- 14.** 12-15V A/C or D/C input to trigger power up with voltage from another device, such as a receiver.
- 15.** Speaker channel output binding posts.
- 16.** Speaker channel bridged mode binding.
- 17.** 3-Prong removable power plug.
- 18.** Fused AC

SYSTEM DESIGN & OPERATION CONSIDERATIONS

To best understand system design and operation of the PT8000CH, it is useful to understand the following terms and features as they relate to the PT8000CH.

Multi-Room

A system design that plays the same source at the same time in all rooms. If a change is made in one room, the same changes takes place in all other rooms. For example, if a listener changes from CD to Tuner in the bedroom, the same change will be heard in the kitchen.

Note: With the use of volume controls or speaker switchers the volume of each room can be controlled separately of the other rooms.

Multi-Zone

A system design that allows different sources to be played in each room. A change in one room can be made without changing the other rooms. For example the CD player can be heard in the bedroom while the kitchen is playing the tuner.

Bridging

The combining of 2 channels to create one mono channel. It is useful when more volume is needed in a particular area.

Source

Component, audio or video, that provides an audio signal. Examples are CD, VCR, DVD, tape deck and tuner. The source provides the audio information that is amplified by the PT8000CH.

Channel

A distinct unit of the amplifier that provides output to one speaker. On the PT8000CH the input to each channel can be configured to select from the BUS INPUT, the AUX INPUT or that channel's unique CHANNEL INPUT. Two adjacent channels can be bridged to provide higher power to one speaker.

Level Controls

Allows any of the channels to be adjusted independently to raise or lower the output of each channel. This may be used to control the speaker output in order to balance different rooms or areas of the system.

BUS* AUX* LINE Switch

Allows each channel to play a variety of different inputs. Depending on the switch position the channel amplifies the signal connected to the BUS input, the AUX input, or its own LINE input.

R R + L L Switch

When either a BUS or AUX input is selected, this switch is used to direct the channel to play the left signal from the input "L" or the right signal from the input "R", or a combined right and left signal from the input "R+L".

Bus Input

Allows the signal from a source to be distributed to any of the 12 channels on the amplifier.

Auxiliary Inputs

Allows the signal from a secondary source to be distributed to any of the 12 channels of the amplifier.

Power Mode Selection

There are three ways to turn the amplifier on and off. Use the following list to decide which mode will work best for your application. See Diagram 3 below.

1. Constant

Use this selection when you wish to manually turn the amplifier on and off by using the front mounted power button.

2. Trigger

Use this selection if you wish the amplifier turn on when it receives voltage (12-15V A/C or D/C) from an external source and turn off once that voltage has stopped. Some components have voltage outputs that are designed for this use. In addition there are devices that can be used as part of an automated system that will provide voltage to enable the mode. The voltage source must be connected to the trigger-input jack on the back of the amplifier.

3. Audio Sense

Use this selection when you want the amplifier to turn on when the amplifier's main input receives an audio signal. At the moment that either the left or right input jacks receive a signal the amplifier is turned on. Once the signal stops the amplifier waits 3 minutes and then turns off.

DIAGRAM 3: POWER MODE SELECTION

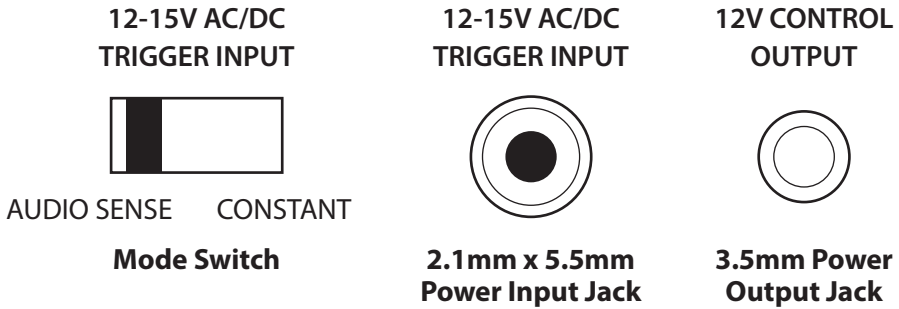

SYSTEM DESIGN EXAMPLES

There are many ways to configure the PT8000CH amplifier. The following pages contain some typical installation examples. Use these examples to generate ideas for your system design.

Multi-Room Installation Example (Diagram 4)

This illustrates the simplest use of the PT8000CH, distributing audio throughout the home. In this example only one source can be selected at a time, all pairs of speakers have the same audio signal available. The Input Selection switch is set to "BUS" on all channels. Adjacent channels are assigned left and right.

Multi-Zone Example #1 (Diagram 5)

This illustrates the simplest way to provide an audio signal to one area that is independent of the main audio signal. Zone 2 uses a CD player connected to just that Zone. The rest of the system operates Zone 1 and is connected to the preamplifier/receiver. The Input Selection switch on channels 1-10 is set to "BUS" with adjacent channels assigned left and right. The Input Selection Switch on channels 11 and 12 are set to "LINE".

Multi-Zone Example #2 (Diagram 6)

This illustrates the ability to listen to different audio signals in each zone, independent of every other zone. The system relies on a multi-zone preamplifier or up to 6 independent preamplifiers.

The Input Selection switch on each channel is set to "LINE"

Home Theater / Multi-Room Example (Diagram 7)

This configuration allows the user to access the sources connected to a home theater receiver for use in a multi-room installation. It relies on the home theater receiver having a multi-room or similar output.

The Input Selection switch on each channel is set to "BUS" with adjacent channels assigned left and right.

DIAGRAM 4 - MULTI-ROOM INSTALLATION

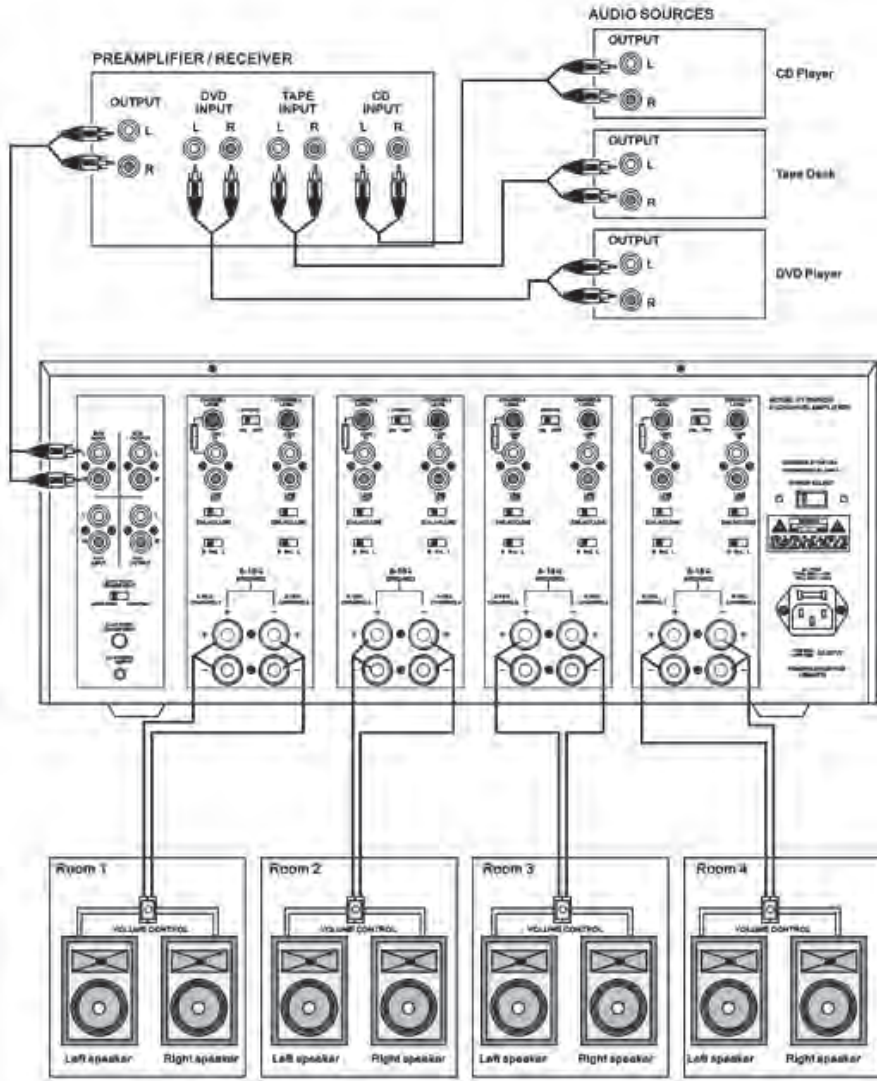

DIAGRAM 5 - MULTI-ZONE INSTALLATION #1

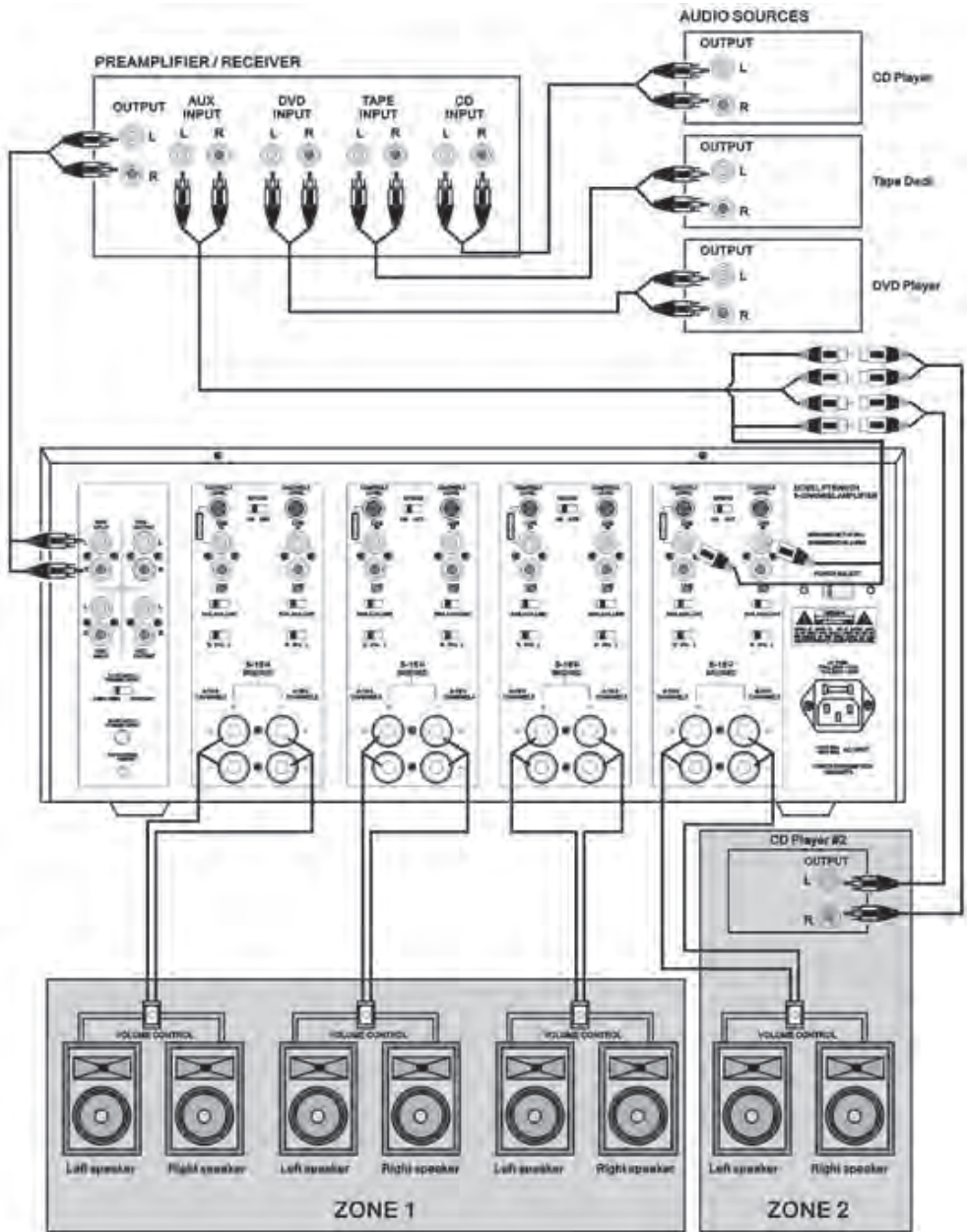

DIAGRAM 6 - MULTI-ZONE INSTALLATION #2

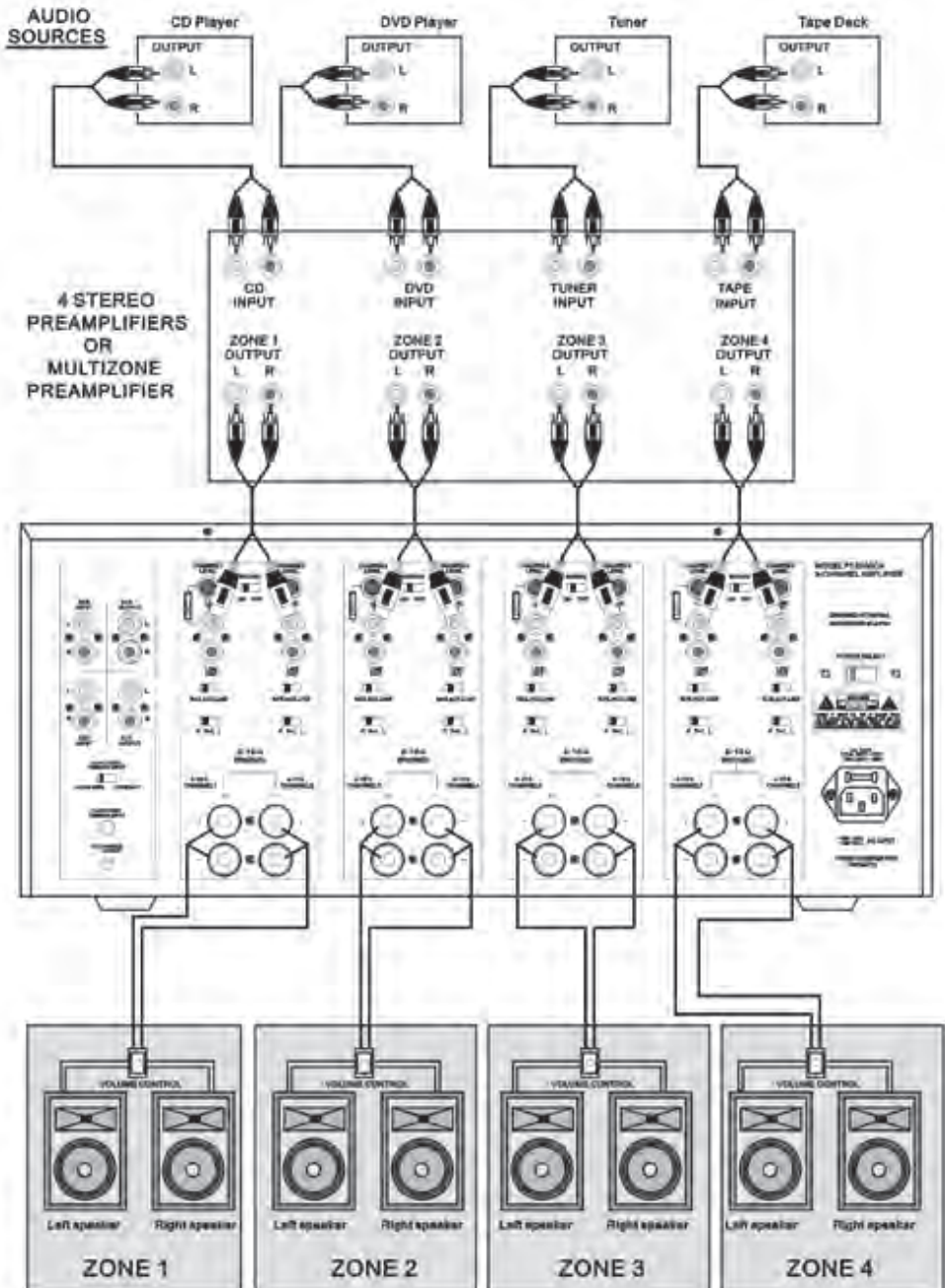
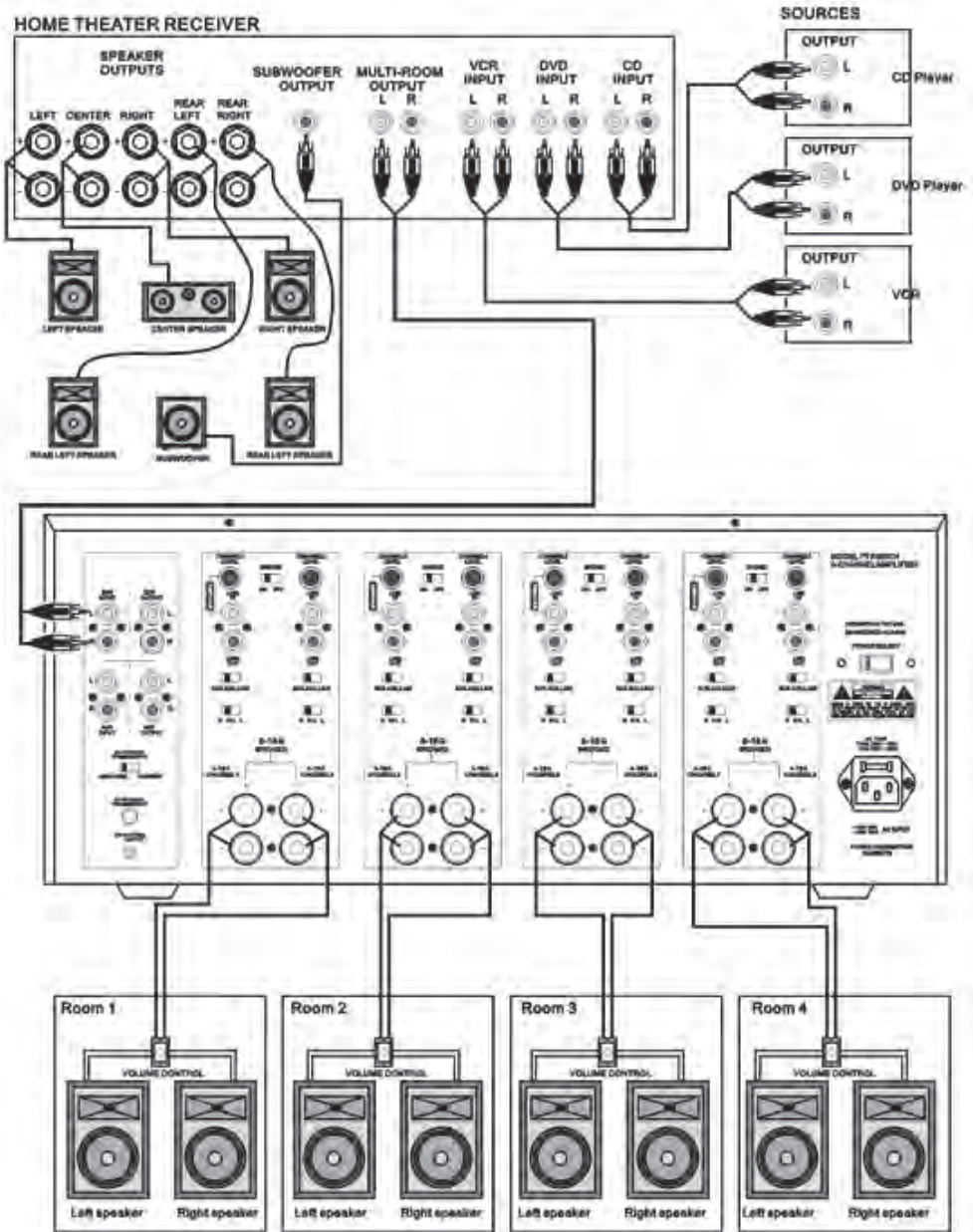

DIAGRAM 7 - HOME THEATER/MULTI-ROOM INSTALLATION



INSTALLATION CONSIDERATIONS

DO:

- Place the amplifier with the feet resting on a solid flat level surface.
- Place the amplifier in a well-vented area to provide proper cooling. In areas that lack proper ventilation, such as tight cabinets or racks, it may be necessary to install small fans to create air movement.

DON'T:

- Don't block the ventilation holes on the top or bottom of the amplifier. Never place it on carpeting or similar material.
- Don't place the amplifier in any other position other than horizontal with the feet down. Never place on its side or resting on the back where the terminals are located.
- Don't the amplifier near heat sources, or in an area that it would be exposed to moisture.

YOU SHOULD KNOW

- The power supply is very large and therefore may cause a hum to be heard in some components if they are placed very close to the amplifier.

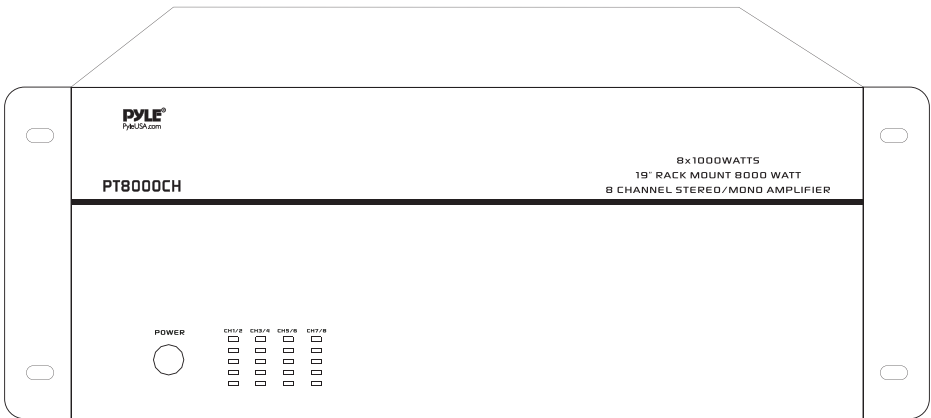

INSTALLATION

CAUTION: All connections and switching must be done with the amplifier's master power switch positioned to "off".

Select the Power Mode Selection

Refer to the Power Mode Selection area under installation considerations to determine which setting to use to turn the amplifier on. Once you have determined which mode you will be using set the switches as outlined in the following chart:

SELECTION MODE	SWITCH SETTINGS	ACTIVE LIGHT
Constant	Power Mode Selection = Set to "Constant". Master Power Button = Push to "In" position to turn amplifier "On", out position is "Off"	Will light up when the amplifier is "On/Active" and will go off when it is "off"
Trigger	Power Mode Selection = Set to "Trigger". Master Power Button = Leave in the "On" position (Button in).	Will light up only when the amplifier receives a voltage indicating the amplifier is "On/Active". Will turn off once the voltage has stopped.
Audio Sense	Power Mode Selection = Set to "Audio Sense". Master Power Button = Leave in the "On" position (Button in)	Will light up only when the amplifier receives an audio signal to the main inputs indicating the amplifier is "ON"/active. Will turn off three minutes after the signal has stopped

Selecting Inputs (See Diagrams 8 & 9)

Each channel is capable of delivering the source from many inputs. The three main inputs are BUS, AUX and LINE IN. The selection for these inputs is done via the Input Selection switch, marked "BUS-AUX-LINE". To select a source for each channel, follow the steps below:

1. Select the desired source input. Set the Input Selection switch to BUS (will play source connected to the BUS INPUT), AUX (will play source connected to the AUX INPUT) or LINE (will play source connected to the LINE IN).

Diagram 8



BUS.AUX.LINE

2. The BUS and AUX inputs each have a left and right input. The left, right or combined left and right signal from these may be selected via the switch marked "R R+L L". Select the side you want the channel to deliver. Selecting "R" ± will play the right channel of the selected input. Selecting "L" will play the left channel of the selected input. Selecting "R+L" will play the combined signals of right and left.

Diagram 9



R R+L R

Selecting Bridge Mode (See Diagram 10)

Under normal operation, this should be left in the 8 ohm position. It is sometimes desirable to combine two channels into one through bridging. The output of the combined channels can then be used to power one speaker.

To bridge two adjacent channels first make sure that the Impedance Switch is in the 8ohm position. Next move the switch marked "BRIDGE" to the "ON" position.

The speaker must be connected to the terminals immediately under the "BRIDGED" text as indicated in Diagram 10. All input selection and settings for the bridged channels will be done on the channel to the left.

Do not connect more than one speaker to the outputs of the bridged channel.

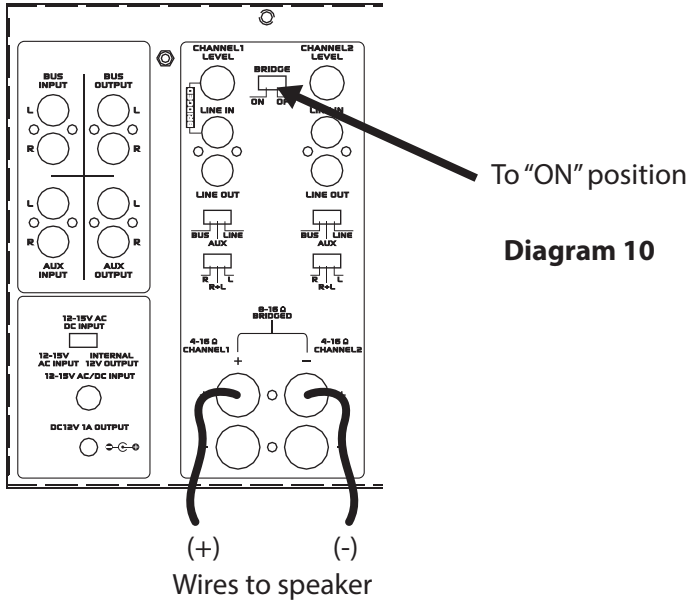

Diagram 10

Control Output

The 12V output jack on the back of the amplifier can be used to turn on a variety of components equipped to be activated when they receive a 12V DC output. Voltage is only delivered to the jack when the amplifier is "on" or active. When the amplifier turns off, the voltage ceases.

Before connecting another device to the 12 output please make sure that the device can accept 12V DC at 150ma. To connect the output to another device you must access the output jack with a two-conductor plug that fits into the 3.5mm jack. Be aware that the tip of the plug will be (+). If you are unsure about using this feature please contact an authorized PYLEUSA dealer for assistance.

Connecting the Speaker Wires

CAUTION: Only make connections when the amplifier is turned off.

Using Standard Connections (See Diagram 11)

For best performance use high quality speaker cables. The banana plug outputs on the back of the amplifier allow for a variety of ways to connect your speakers to the amplifier.

Diagram 11: Binding Post Detail

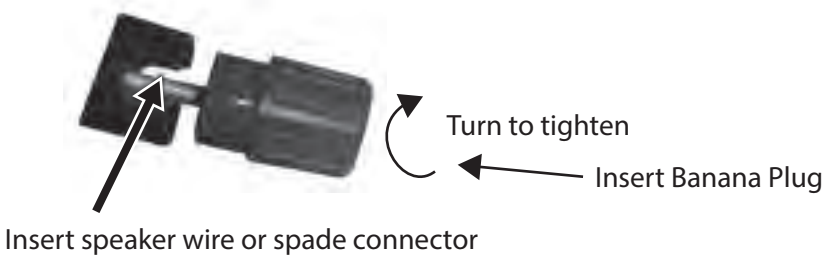

Connecting the Line Level Audio Inputs

CAUTION: Only make connections when the amplifier is turned off.

There are three areas that an input signal can be connected, BUS, AUX and LINE IN. Refer to the System Design Examples to determine which is best suited for your application.

Audio Outputs

Sources connected to the "BUS" or "AUX" inputs can be forwarded to other components or amplifiers by connecting to the corresponding output sections to the right of each input section. By using standard audio patch cables, you can connect these outputs to the inputs of another amplifier. Up to 5 amplifiers can be daisy-chained together.

AC Power

Plug the socket of the AC cord supplied with the amplifier into the receptacle on the rear of the amplifier. Plug the 2 prong plug directly into a 120V 60Hz wall outlet.

CAUTION: Do not plug the amplifier into the preamplifier or receivers switched outlet. If you wish to have the amplifier turn on once the preamplifier or receiver is activated, use one of the turn on modes, voltage or audio.

OPERATION

See Diagram 1 for the location of the following:

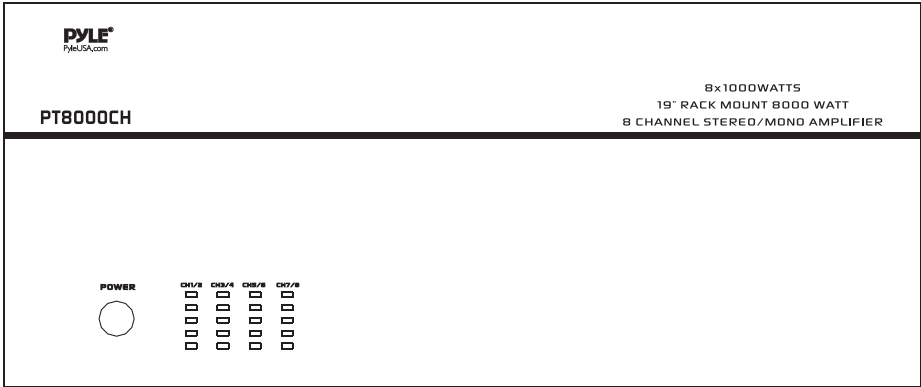

Power Switch

The switch marked "Power" on the front panel of the amplifier will turn off all amplifier circuitry no matter which turn on mode is selected.

Refer to the "Power Mode Selection" section for further information.

Active LED

When lit, the Active LED indicates that the amplifier is operating. Refer to the "Power Mode Selection" section of this manual for further information.

Protection LEDs

When lit the "Protection" LEDs located on the front of the amplifier indicate that either a fault in the wiring, the speaker, or the amplifier has caused the channels associated with the LED to shut down.

Level Adjustment Knobs

The level adjustment knobs on the back panel of the amplifier can be used to adjust the level of each channel. There are many reasons for needing to adjust the level. You may wish to closely match other levels in the system, or you may wish to limit the volume level in an area, such as a child's room.

TROUBLESHOOTING

The amplifier is designed to function trouble-free. Most problems occur because of operating errors. If you have a problem please check the troubleshooting list first. If the problem persists, contact your authorized dealer.

PROBLEM	POSSIBLE CAUSES AND SOLUTIONS
No sound is heard on all channels	<p>Audio cable to the source component is not connected properly or the cable is bad. Use another cable that you know is good.</p> <p>The Input Selection switch is positioned incorrectly. Refer to installation instructions for proper settings.</p> <p>Some or all of the internal fuses are blown. Return the amplifier to your dealer for servicing.</p>
No sound is heard on one or some channels	<p>Audio cable to the source component is not connected properly or the cable is bad. Use another cable that you know is good.</p> <p>The Input Selection switch is positioned incorrectly. Refer to installation instructions for proper settings.</p> <p>The Bridging switch is positioned incorrectly. Refer to installation instructions for proper settings.</p> <p>Check the termination points of the speaker cable at both the amplifier and speaker. If Connector, check the connections at the levers. A speaker is not working. Make sure by connecting the channel to a speaker that you know to be working.</p> <p>The level adjustment on the channel is turned all the way down. Turn it clockwise to raise the volume.</p> <p>Some or all of the internal fuses are blown. Return the amplifier to your dealer for servicing.</p>

PROBLEM	POSSIBLE CAUSES AND SOLUTIONS
<p>No sound is heard on all channels</p>	<p>Audio cable to the source component is not connected properly or the cable is bad. Use another cable that you know is good.</p> <p>The Input Selection switch is positioned incorrectly. Refer to installation instructions for proper settings.</p> <p>Some or all of the internal fuses are blown. Return the amplifier to your dealer for servicing.</p>
<p>Hum or buzzing sound is heard.</p>	<p>The sound may be caused by a ground loop in the system. Try to eliminate this by reversing the AC plugs of other components in the system.</p> <p>Other causes include faulty cables.</p>
<p>Amplifier will not turn on</p>	<p>The amplifier must be plugged into a live outlet. The power switch on the front panel must be on.</p> <p>The Power Mode switch may be positioned incorrectly.</p>



WARNING:

This product can expose you to a chemical or group of chemicals, which may include "Nickel Carbonate" which is known in the state of California to cause cancer, birth defects, or other reproductive harm. For more info, go to <https://www.p65warnings.ca.gov/>.

FEATURES:

- Multi-Zone Audio Source Amplifier System
- High-Powered & Distortion-Free Audio Distribution
- 8-Channel Sound Processing Amp Design
- Integrated 4-Channel Bridgeable (Bridge) Switches
- Front Panel Color LED Graphic Audio Level Display
- Independent Channel Rotary Level Control Knobs
- Channel Configuration: Left/Right/Mono - Bus/AUX Input
- Gold-Plated Audio/Speaker Connectors
- 5-Way Speaker Binding Posts (Banana Plug) Outputs
- Pass-Through Output for External Amplifier Linking (Daisy-Chaining)
- Individual Channel Safety with Protection & Overload Circuitry
- Master Power Button, ON/OFF
- Universal Rack Mount Compatibility
- Perfect for Home Theaters & Multi-Room Audio Control
- Used in Home, Office & Business Applications

WHAT'S IN THE BOX:

- 8-Channel Amplifier
- Power Cable

TECHNICAL SPECS:

- MAX Power Output: 8-Ch. x 1000 Watt
- RMS Power Output: 100W x 8-Ch @ 8Ohm
- T.H.D.: <1%
- Rack Mountable: 4U Rack Space
- Power: 115/230V Switchable (DC 12-15V)
- Dimension (W x D x H): 19.0" x 19.3" x 7.1"

PYLE

PyleUSA.com



VISIT US ONLINE:

Have a question?

Need service or repair?

Want to leave a comment?

PyleUSA.com/ContactUs

PYLE

Questions? Issues?

We are here to help!

Phone: (1) 718-535-1800

Email: support@pyleusa.com