

COLORADO *BATTEN* Q15

User Manual

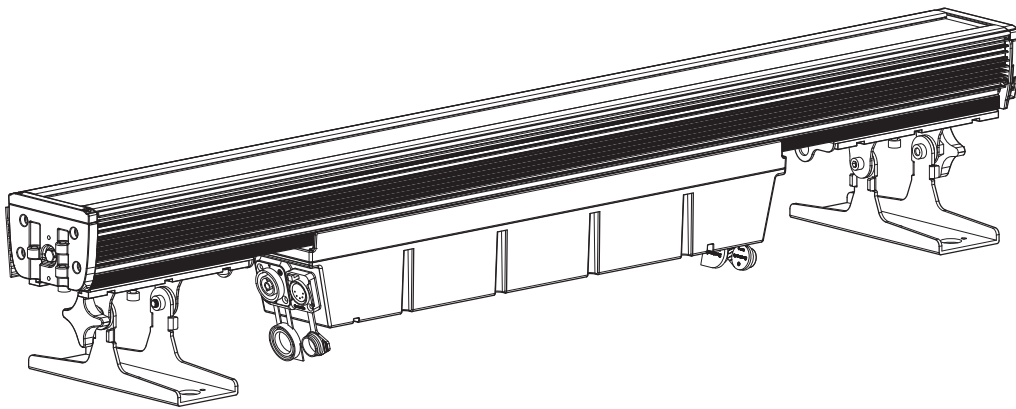

Model ID: COLORADOBATTENQ15

CHAUVET
PROFESSIONAL

Edition Notes

The COLORado Batten Q15 User Manual includes a description, safety precautions, installation, programming, operation and maintenance instructions for the COLORado Batten Q15 as of the release date of this edition.

Trademarks

CHAUVET, the Chauvet logo and COLORado Batten Q15 are registered trademarks or trademarks of Chauvet & Sons, LLC (d/b/a Chauvet and Chauvet Lighting) in the United States and other countries. Other company and product names and logos referred to herein may be trademarks of their respective companies.

Copyright Notice

The works of authorship contained in this manual, including, but not limited to, all design, text and images are owned by Chauvet.

© **Copyright 2021 Chauvet & Sons, LLC. All rights reserved.**

Electronically published by Chauvet in the United States of America.

Manual Use

Chauvet authorizes its customers to download and print this manual for professional information purposes only. Chauvet expressly prohibits the usage, copy, storage, distribution, modification, or printing of this manual or its content for any other purpose without written consent from Chauvet.

Document Printing

For best results, print this document in color, on letter size paper (8.5 x 11 in), double-sided. If using A4 paper (210 x 297 mm), configure the printer to scale the content accordingly.

Intended Audience

Any person installing, operating, and/or maintaining this product should completely read through the guide that shipped with the product, as well as this manual, before installing, operating, or maintaining this product.

Disclaimer

Chauvet believes that the information contained in this manual is accurate in all respects. However, Chauvet assumes no responsibility and specifically disclaims any and all liability to any party for any loss, damage or disruption caused by any errors or omissions in this document, whether such errors or omissions result from negligence, accident or any other cause. Chauvet reserves the right to revise the content of this document without any obligation to notify any person or company of such revision, however, Chauvet has no obligation to make, and does not commit to make, any such revisions. Download the latest version from www.chauvetprofessional.com.

Document Revision

This COLORado Batten Q15 User Manual is the 2nd edition of this document. Go to www.chauvetprofessional.com for the latest version.

TABLE OF CONTENTS

1. Before You Begin	1
What Is Included	1
Claims.....	1
Text Conventions.....	1
Symbols.....	1
Safety Notes	2
Personal Safety	2
Mounting and Rigging.....	2
Power and Wiring	2
Operation.....	2
Expected LED Lifespan	2
2. Introduction	3
Description.....	3
Features	3
Product Overview	3
Product Dimensions	4
3. Setup	5
AC Power	5
AC Plug.....	5
Power Linking	5
Remote Device Management (RDM)	5
Filter Installation	5
Mounting.....	6
Orientation	6
Rigging.....	6
Procedure	6
Base Plate	7
Attaching the Base Plate.....	7
Mounting Diagram (with Base Plate)	8
Series Attachment Instructions	9
Mounting Products Attached in Series.....	10
4. Operation	11
Control Panel Description.....	11
Control Options.....	11
Programming	11
Menu Map.....	11
Configuration (DMX).....	13
Control Personalities.....	13
Starting Address	13
Control Channel Assignments and Values	14
Color Macro Chart	14
Color Temperature Chart.....	14
15-Cell DMX Values	14
15 HSIC (76 Channels).....	14
15 Advanced (66 Channels)	17
15 Basic (64 Channels).....	19
15 Simple (60 Channels)	20
15 Pixel (45 Channels).....	21

1-Cell DMX Values	22
1 HSIC (6 Channels).....	22
1 Advanced (10 Channels)	23
1 Basic (8 Channels).....	23
1 Simple (4 Channels)	23
Configuration (Standalone).....	24
Static Colors	24
Preset Colors	24
Preset Color Temperatures.....	24
Custom Color Mixing.....	24
Automatic Programs	24
Run Program.....	24
Customize Program	24
Configuration (Settings).....	24
Output Setting.....	24
Master/Slave	24
Dimmer Mode	25
Pulse Width Modulation	25
Cell Order	25
DMX Error/Loss	25
Display Timeout.....	25
Display Passcode	25
Product Information	25
Factory Reset	25
5. Maintenance.....	26
Product Maintenance.....	26
6. Technical Specifications	27
7. Returns.....	28
8. Contact Us	29

Before You Begin

1. Before You Begin

What Is Included

- COLORado Batten Q15
- Seetronic Powerkon IP65 Power Cord
- 2 Omega Brackets
- Base Plate
- 2 Retaining Pins
- Glare Shield
- Filter
- Quick Reference Guide

Claims

Carefully unpack the product immediately and check the container to make sure all the parts are in the package and are in good condition.



If the box or the contents (the product and included accessories) appear damaged from shipping, or show signs of mishandling, notify the carrier immediately, not Chauvet. Failure to report damage to the carrier immediately may invalidate your claim. In addition, keep the box and contents for inspection.

For other issues, such as missing components or parts, damage not related to shipping, or concealed damage, file a claim with Chauvet within 7 days of delivery.

Text Conventions

Convention	Meaning
1–512	A range of values
50/60	A set of values of which only one can be chosen
Settings	A menu option not to be modified
<ENTER>	A key to be pressed on the product's control panel

Symbols

Symbol	Meaning
	Critical installation, configuration, or operation information. Not following these instructions may make the product not work, cause damage to the product, or cause harm to the operator.
	Important installation or configuration information. The product may not function correctly if this information is not used.
	Useful information.



Any reference to data or power connections in this manual assumes the use of Seetronic IP rated cables.



The term “DMX” used throughout this manual refers to the USITT DMX512-A digital data transmission protocol.

FCC Compliance

This device complies with Part 15 Part B of the FCC Rules. Operation is subject to the following two conditions:

1. This device may not cause harmful interference, and
2. This device must accept any interference received, including interference that may cause undesired operation.

Any changes or modifications not expressly approved by the party responsible for compliance could void the user's authority to operate the equipment.

Safety Notes

Read all the following safety notes before working with this product. These notes contain important information about the installation, usage, and maintenance of this product.



This product contains no user-serviceable parts. Any reference to servicing in this User Manual will only apply to properly trained, certified technicians. Do not open the housing or attempt any repairs.



All applicable local codes and regulations apply to proper installation of this product.

Personal Safety

- Avoid direct eye exposure to the light source while the product is on.
- Always disconnect the product from the power source before cleaning or replacing the fuse.
- Always connect the product to a grounded circuit to avoid the risk of electrocution.
- Do not touch the product's housing when operating because it may be very hot.

Mounting and Rigging

- Do not submerge this product (IP65). Temporary outdoor operation is fine.
- When using this product in an outdoor environment, use IP65 (or higher) rated power and data cables. Secure unused power and data ports with attached IP65 covers.
- CAUTION: When transferring product from extreme temperature environments, (e.g., cold truck to warm, humid ballroom) condensation may form on the internal electronics of the product. To avoid causing a failure, allow product to fully acclimate to the surrounding environment before connecting it to power.
- Not for permanent outdoor installation in locations with extreme environmental conditions. This includes, but is not limited to:
 - Exposure to a marine/saline environment (within 3 miles of a saltwater body of water).
 - Locations where the normal high or low temperatures exceed the temperature ranges in this manual.
 - Locations that are prone to flooding or being buried in snow.
 - Areas where the product will be subjected to extreme radiation or caustic substances.
- Mount this product in a location with adequate ventilation, at least 20 in (50 cm) from adjacent surfaces.
- Make sure there are no flammable materials close to the product when operating.
- When hanging this product, always secure to a fastening device using a safety cable.

Power and Wiring

- Make sure the power cord is not crimped or damaged.
- Always make sure you are connecting this product to the proper voltage in accordance with the specifications in this manual or on the product's specification label.
- To eliminate unnecessary wear and improve its lifespan, during periods of non-use completely disconnect the product from power via breaker or by unplugging it.
- Never connect this product to a dimmer pack or rheostat.
- Make sure to replace the fuse with another of the same type and rating.
- Never disconnect this product by pulling or tugging on the power cable.

Operation

- Do not operate this product if there is damage on the housing, lenses, or cables. Have the damaged parts replaced by an authorized technician at once.
- Do not cover the ventilation slots when operating to avoid internal overheating.
- The maximum ambient temperature is 113 °F (45 °C). Do not operate the product at higher temperatures.
- The minimum startup temperature is -4°F (-20°C). Do not start the product at lower temperatures.
- The minimum ambient temperature is -22°F (-30°C). Do not operate the product at lower temperatures.
- In the event of a serious operation problem, stop using this product immediately!



If your Chauvet product requires service, contact Chauvet Technical Support.

Expected LED Lifespan

Over time, use and heat will gradually reduce LED brightness. Clustered LEDs produce more heat than single LEDs, contributing to shorter lifespans if always used at full intensity. The average LED lifespan is 40,000 to 50,000 hours. To extend LED lifespan, maintain proper ventilation around the product, and limit the overall intensity.

2. Introduction

Description

The COLORado Batten Q15 is a quad-color RGBW LED batten with 15 individually controllable LEDs that eliminate the appearance of “skittles” and allow for awesome pixel-mappable looks. The IP65-rated product features tremendous output with selectable, smooth dimming curves, convenient color temperature presets and an extraordinary reach with a native 16° beam angle. An included wall wash filter creates a 16° by 43° beam spread for guaranteed smoothness. Mount it your way by adjustable trunnions with ¼ turn adapters for the Omega Bracket, innovative end-cap, or back plate mounting for seamless row alignment, icicles, and floor mounting. The unit also includes a stow-able glare shield.

Features

- Operating modes:
 - 1 Simple (4-channel): RGBW
 - 1 Basic (8-channel): 16-bit dimmer, RGBW, color macros, strobe
 - 1 Advanced (10-channel): 16-bit dimmer, RGBW, color macros, color temperature, strobe, dimmer speed
 - 1 HSIC (6-channel): dimmer, 16-bit hue, saturation, strobe, dimmer speed
 - 15 Pixel (45-channel, 15-cell): RGB (per cell)
 - 15 Simple (60-channel, 15-cell): RGBW (per cell)
 - 15 Basic (64-channel, 15-cell): 16-bit dimmer, RGBW (per cell), color macros, strobe
 - 15 Advanced (66-channel, 15-cell): 16-bit dimmer, RGBW (per cell), color macros, color temperature, strobe, dimmer speed
 - 15 HSIC (76-channel, 15-cell): dimmer (per cell), 16-bit hue (per cell), saturation (per cell), strobe (per cell), dimmer speed
- Quad-Color RGBW LED Batten for touring, rental, and production, indoors or out
- All environment operation with IP rated power and DMX connections
- Unique end-cap and back plate mounting options
- Color temperature presets, from 3200 K to 10000 K
- Selectable, smooth dimming curves for programming versatility
- Built for touring, live event, television, and theatrical productions
- Large, easy to navigate display with password protection

Product Overview

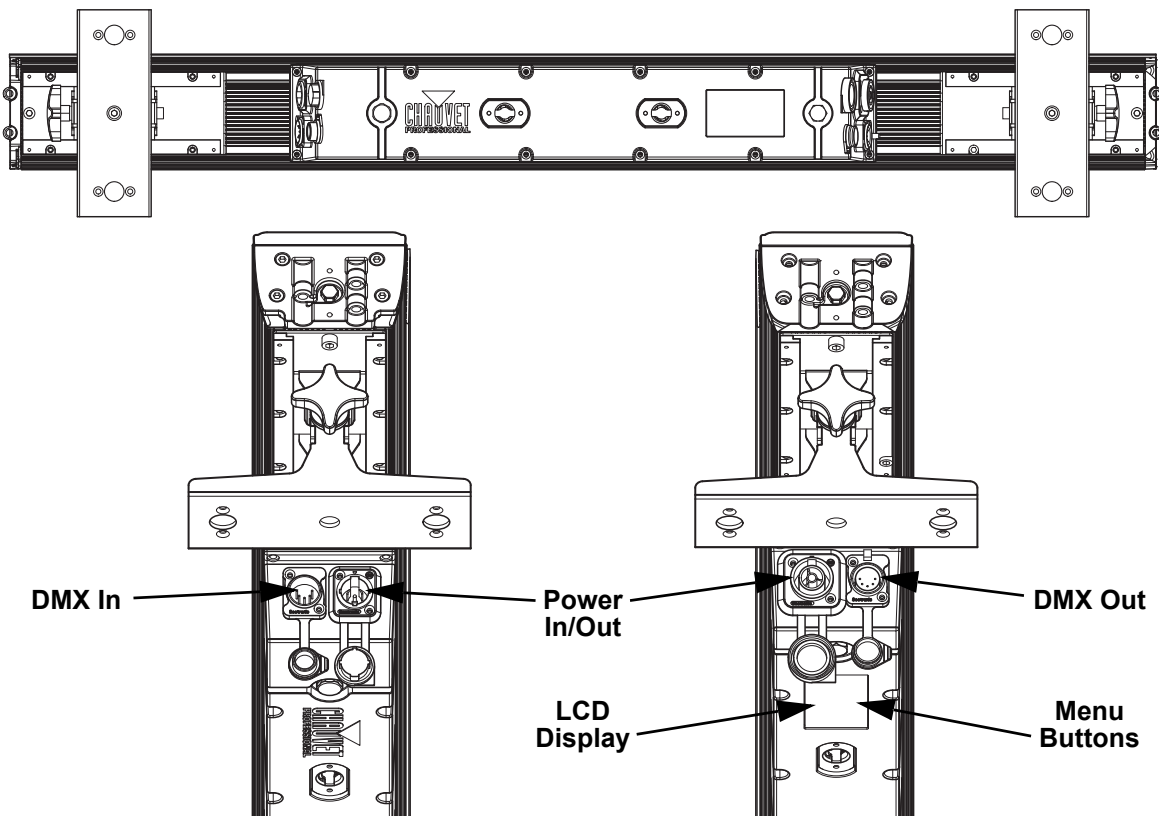

Product Dimensions

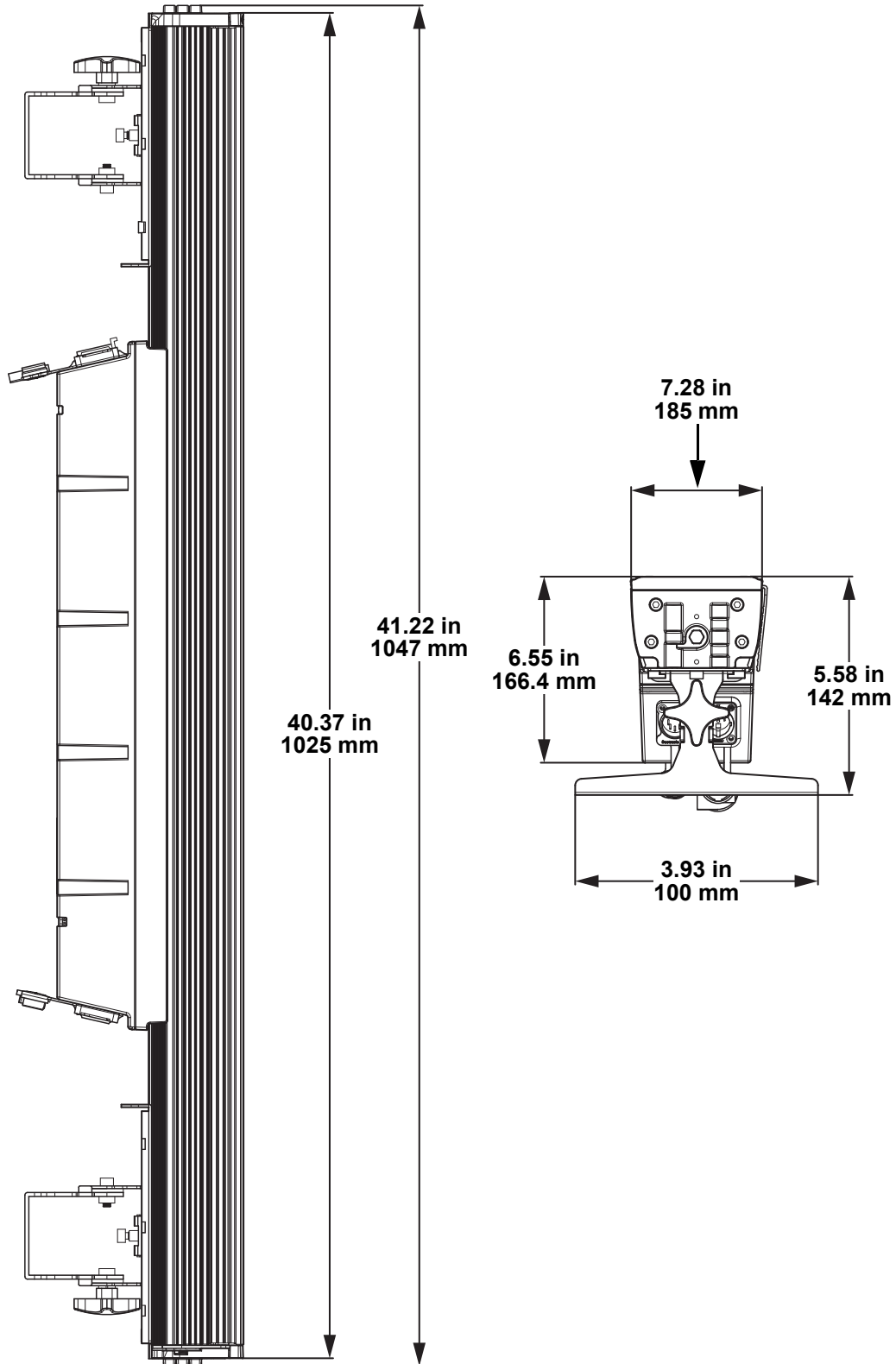

3. Setup

AC Power

The COLORado Batten Q15 has an auto-ranging power supply and it can work with an input voltage range of 100 to 240 VAC, 50/60 Hz.

To determine the product's power requirements (circuit breaker, power outlet, and wiring), use the current value listed on the label affixed to the product's back panel, or refer to the product's specifications chart. The listed current rating indicates the product's average current draw under normal conditions.



- **Always connect the product to a protected circuit (a circuit breaker or fuse). Make sure the product has an appropriate electrical ground to avoid the risk of electrocution or fire.**
- **To eliminate unnecessary wear and improve its lifespan, during periods of non-use completely disconnect the product from power via breaker or by unplugging it.**



Never connect the product to a rheostat (variable resistor) or dimmer circuit, even if the rheostat or dimmer channel serves only as a 0 to 100% switch.

AC Plug

The COLORado Batten Q15 comes with a power input cord terminated with a Seetronic Powerkon A connector on one end and an Edison plug on the other end (U.S. market). If the power input cord that came with your product has no plug, or if you need to change the plug, use the table below to wire the new plug.

Connection	Wire (U.S.)	Wire (Europe)	Screw Color
AC Live	Black	Brown	Yellow or Brass
AC Neutral	White	Blue	Silver
AC Ground	Green/Yellow	Green/Yellow	Green

Power Linking

The product supports power linking. You can power link up to 6 products at 100 V; up to 8 products at 120 V; up to 14 products at 208 V; up to 15 products at 230 V; or up to 16 products at 240 V.

This product comes with a power input cord. Power linking cables are available from Chauvet for purchase.

Remote Device Management (RDM)

Remote Device Management, or RDM, is a standard for allowing DMX-enabled devices to communicate bi-directionally along existing DMX cabling. Check the DMX controller's User Manual or with the manufacturer as not all DMX controllers have this capability. The COLORado Batten Q15 supports RDM protocol that allows feedback to make changes to menu map options.

Filter Installation

The COLORado Batten Q15 includes a filter and a glare shield. Follow the procedure below to install or remove the filter or glare shield.

1. Locate the end of the product on the side which has the power and DMX input ports.
2. Squeeze the filter locking tabs in. The latch bar will pop up.
3. Slide the filter and/or glare shield in or out.
4. Press down on the latch bar until it clicks into place.

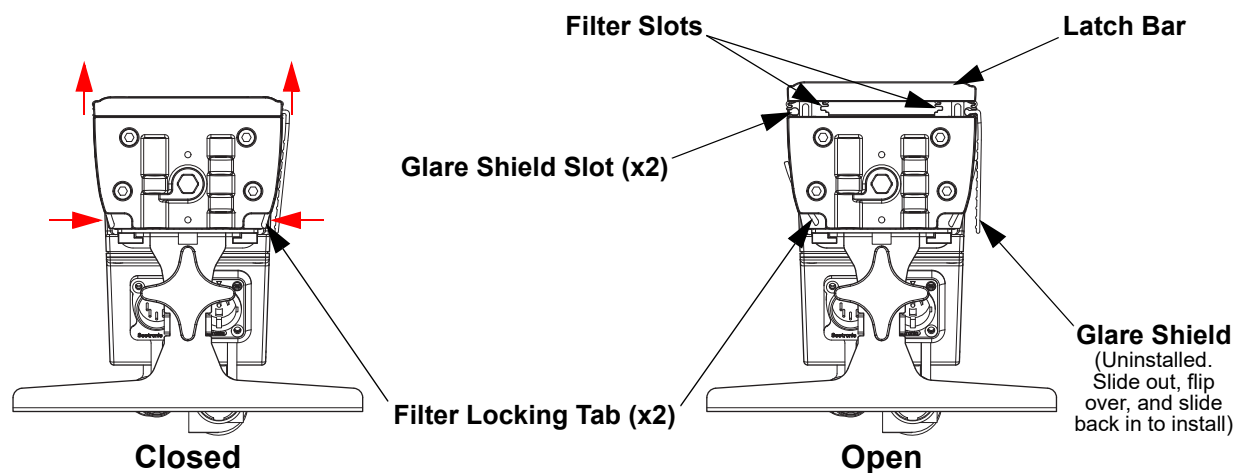

Mounting

Before mounting the product, read and follow the safety recommendations indicated in the [Safety Notes](#). For our CHAUVET Professional line of mounting clamps, go to <http://trusst.com/products/>.

Orientation

Always mount this product in a safe position, making sure there is adequate room for ventilation, configuration, and maintenance.

Rigging

Chauvet recommends using the following general guidelines when mounting this product.

- Before deciding on a location for the product, make sure there is easy access to the product for maintenance and programming purposes.
- Make sure that the structure onto which you are mounting the product can support the product's weight. See the [Technical Specifications](#) for weight information.
- When mounting the product overhead, always use a safety cable. Mount the product securely to a rigging point, whether an elevated platform or a truss.
- When rigging the product onto a truss, use a mounting clamp of appropriate weight capacity.

Procedure

The COLORado Batten Q15 comes with a bracket to which you can attach a mounting clamp directly. Mounting clamps are sold separately. Make sure the clamps are capable of supporting the weight of this product. Use at least two mounting points per product. For the CHAUVET Professional line of mounting clamps, go to <http://www.trusst.com/products>.

Mounting Diagram

2 Mounting Points

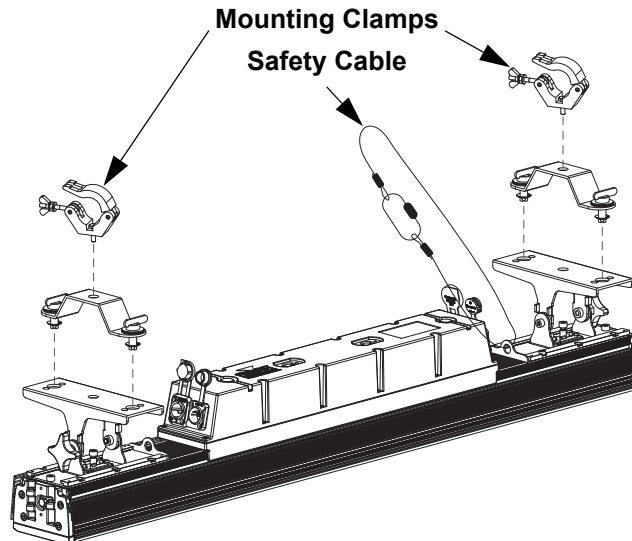

1 Mounting Point

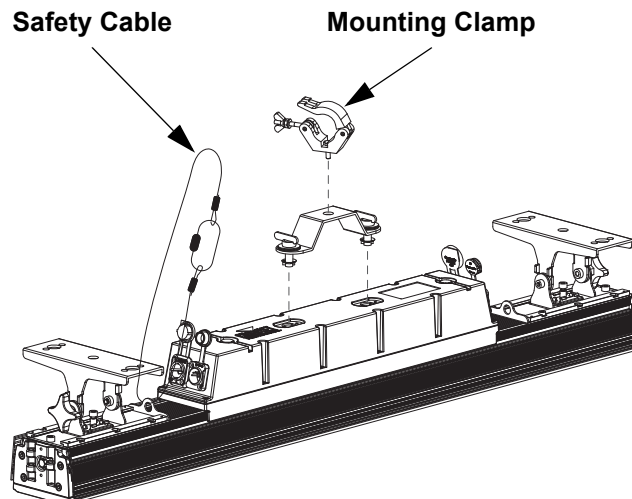

Setup

Base Plate

Each COLORado Batten Q15 comes with a base plate and 2 retaining pins, which can be used for floor mounting or vertical hanging.



The retaining pins each have a safety cable for added security.

Attaching the Base Plate

To attach the base plate to either end of the COLORado Batten Q15:

1. Align the base plate so the loops on the end of the product and the loops on the base plate line up and fit into each other.
2. Tighten the captive screws on the base plate.
3. Press and hold the latch button on the first retaining pin, and insert it through one of the sets of loops on the product and base plate. Release the latch button, then repeat with the other pin.

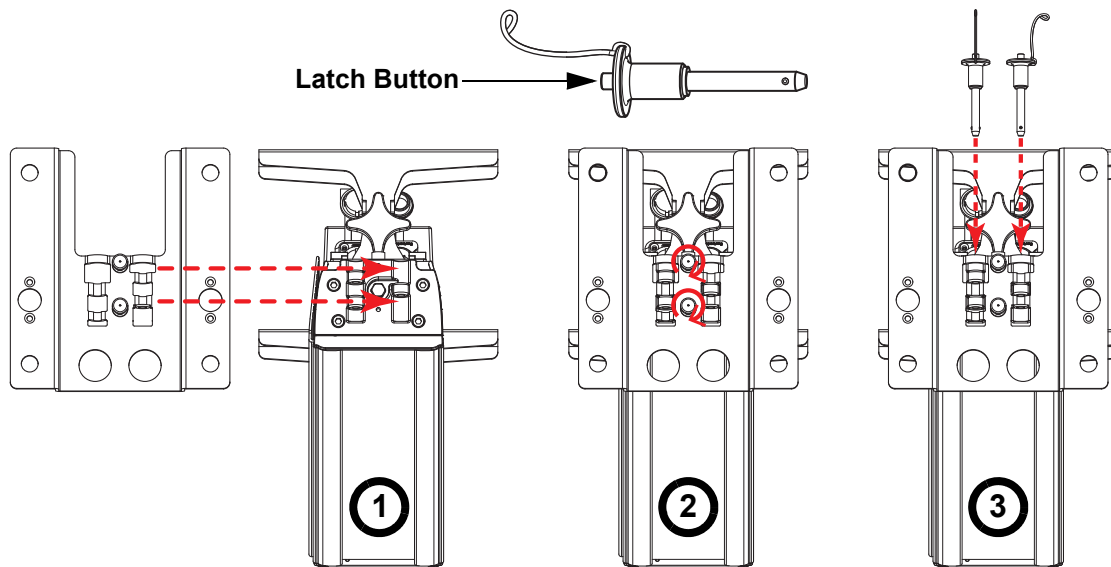

Mounting Diagram (with Base Plate)

Before mounting this product, read the [Safety Notes](#). Make sure the mounting clamp is capable of supporting the weight of the product. For our Chauvet line of mounting clamps, go to <http://trusst.com/productcategory/truss-clamps/>.

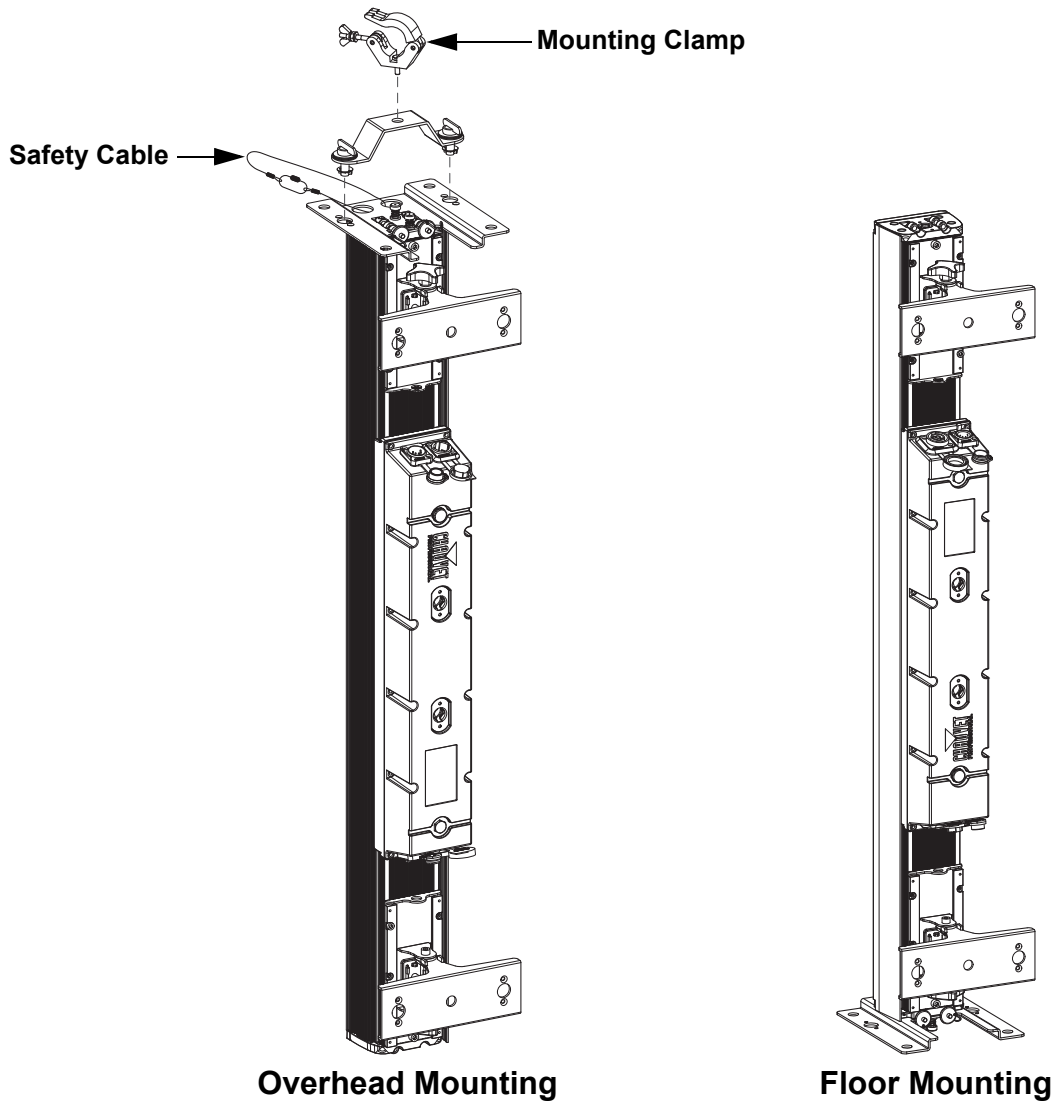

To properly floor-mount this product, the base plate must be bolted to a stable surface, such as the stage floor, or a large base plate.

Series Attachment Instructions

2 COLORado Batten Q15 products can be attached together with the included retaining pins to mount them both from one mounting point. Do not connect any more than 2 COLORado Batten Q15 products in a row when hanging vertically.



The retaining pins each have a safety cable for added security.

To attach 2 products in series:

1. Align them end to end so the loops on either end of the product line up with each other.
2. Press and hold the latch button down on the first retaining pin, and insert it through one of the sets of loops on both products. Release the latch button, then repeat with the other pin.

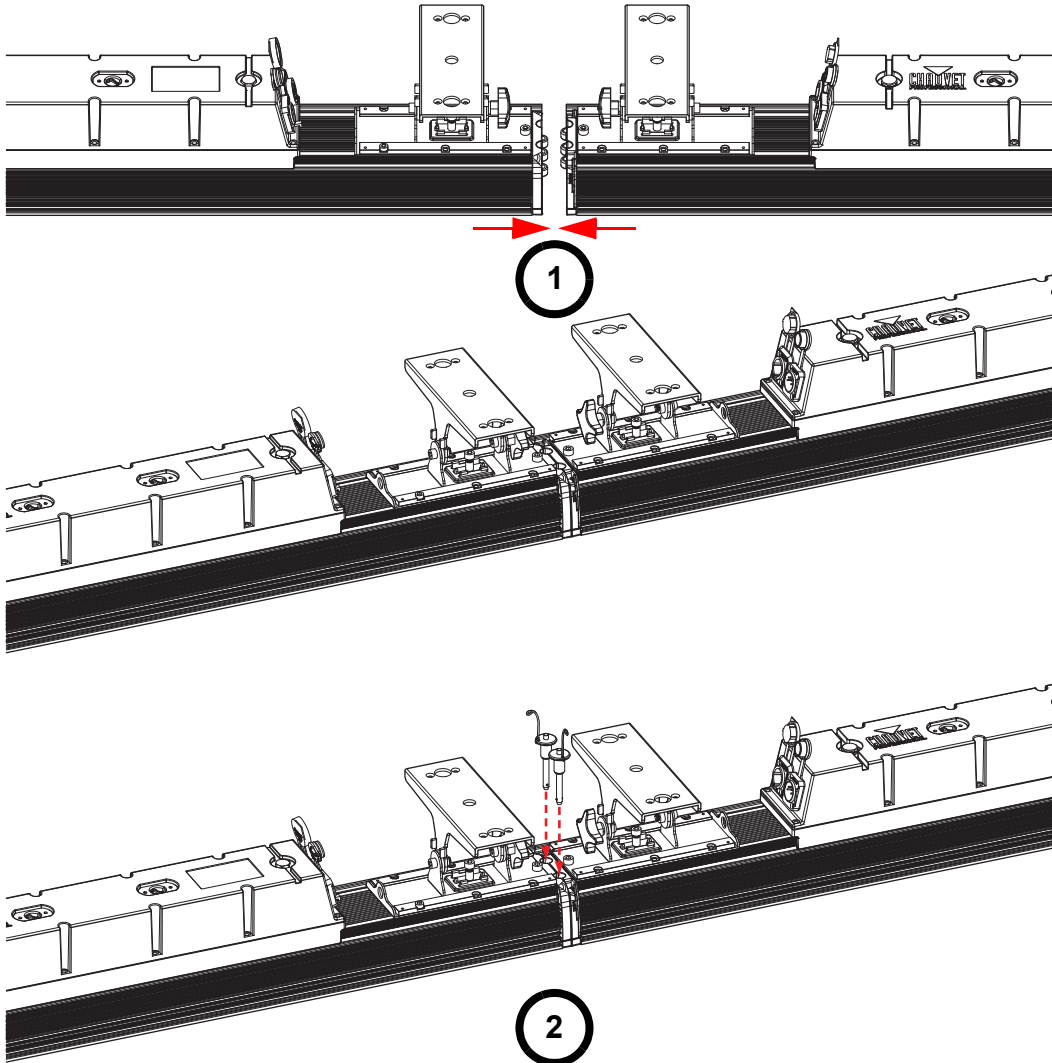

Install the safety cables last when attaching COLORado Batten Q15 products in series.

Mounting Products Attached in Series

1. Attach the base plate to the first product in the series. (See [Attaching the Base Plate](#))
2. Attach an omega bracket to the base plate, and a clamp to the omega bracket.
3. Attach the clamp to the desired structure or surface.
4. Attach a safety cable to the product's safety loop.

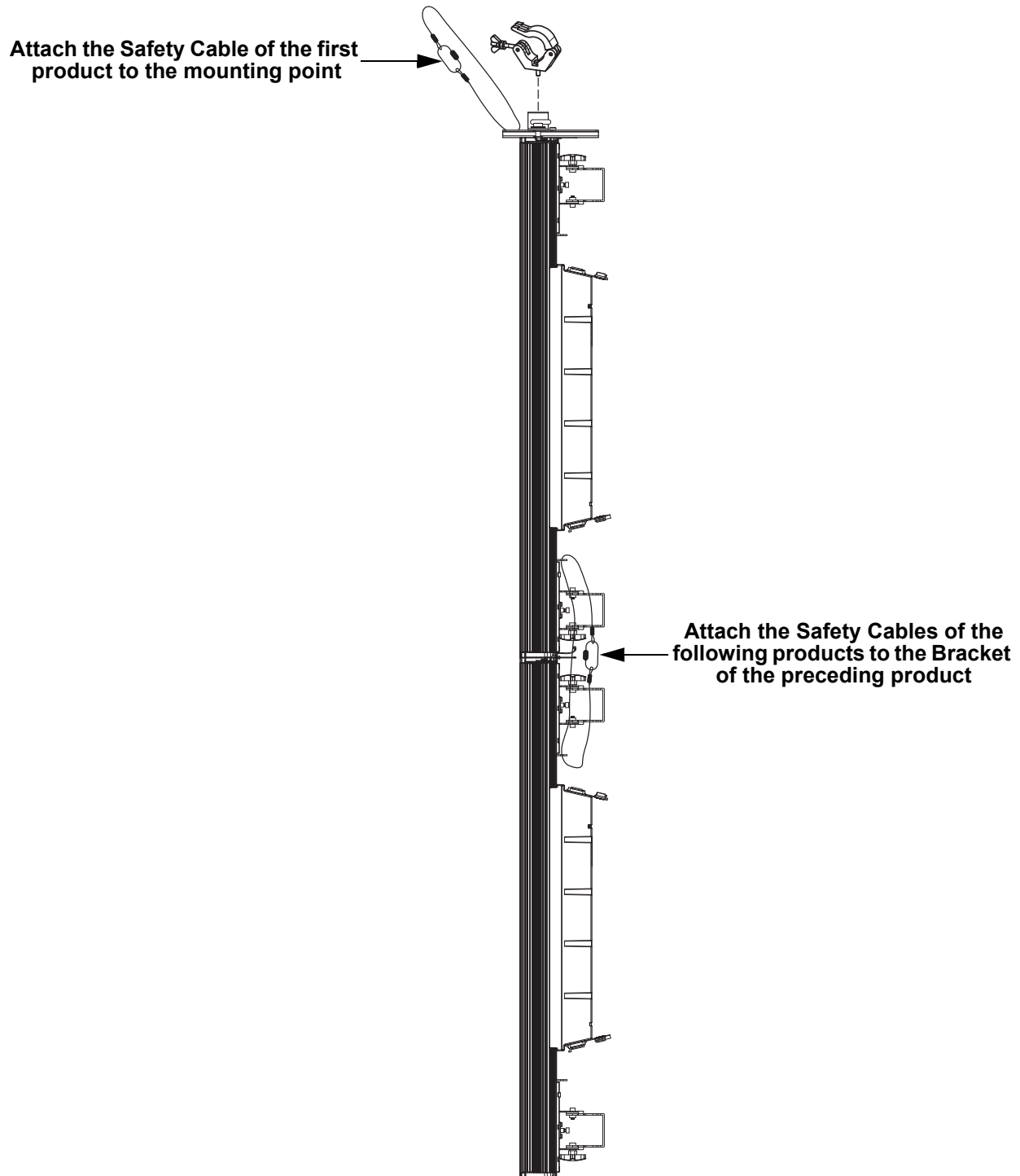

Never attach more than 2 products together when hanging vertically from a single mounting point.

4. Operation

Control Panel Description

Button	Function
<MENU>	Exits from the current menu or function
<UP>	Enables the currently displayed menu or sets the currently selected value in to the current function
<DOWN>	Navigates upward through the menu list or increases the numeric value when in a function
<ENTER>	Navigates downward through the menu list or decreases the numeric value when in a function

Control Options

Set the COLORado Batten Q15 starting address in the 001–509 DMX range. This enables control of up to 6 products in the 76-channel **15 HSIC** personality, or up to 128 products in the 4-channel **1 Simple** personality.

Programming

Refer to the Menu Map to understand the menu options. The menu map shows the main level and a variable number of programming levels for each option.

- To go to the desired main level, press <MENU> repeatedly until the option shows on the display. Press <ENTER> to select. This will take you to the first programming level for that option.
- To select an option or value within the current programming level, press <UP> or <DOWN> until the option shows on the display. Press <ENTER> to select. In this case, if there is another programming level, you will see that first option, or you will see the selected value.
- Press <MENU> repeatedly to exit to the previous main level.

Menu Map

Refer to the COLORado Batten Q15 product page on www.chauvetprofessional.com for the latest menu map.

Main Level	Programming Levels	Description
Start Address	1–509*	Selects DMX address (*highest channel restricted to personality chosen)
	1 Simple	4-channel: RGBW
Personality	1 Basic	8-channel: 16-bit dimmer, RGBW, color macros, strobe
	1 Advanced	10-channel: 16-bit dimmer, RGBW, color macros, color temperature, strobe, dimmer speed
	1 HSIC	6-channel: dimmer, 16-bit hue, saturation, strobe, dimmer speed
	15 Pixel	45-channel (15-cell): RGB (per cell)
	15 Simple	60-channel (15-cell): RGBW (per cell)
	15 Basic	64-channel (15-cell): 16-bit dimmer, RGBW (per cell), color macros, strobe
	15 Advanced	66-channel (15-cell): 16-bit dimmer, RGBW (per cell), color macros, color temperature, strobe, dimmer speed
	15 HSIC	76-channel (15-cell): dimmer (per cell), 16-bit hue (per cell), saturation (per cell), strobe (per cell), dimmer speed

Main Level	Programming Levels			Description
Output Setting	Power Mode			Avoids going over the maximum temperature by adjusting output intensity
	Steady Mode			Uses lower output intensity at a constant rate to avoid going over the maximum temperature
Static Colors	Preset Colors	Color 1–14	0–100%	Preset static colors
	CCT Temper	White 1–14		Preset color temperatures
	RGBW	Red	0–255	Combine red, green, blue, and white to make a custom color
		Green		
Blue				
White				
Auto Programs	Run	AUTO.1–10 Program 1–10		SPEED 0–100%
		Edit	Program 1–10	
	Green 0–255			
	Blue 0–255			
White 0–255				
Master/Slave	Master			DMX mode (Master)
	Slave			Slave mode
Dimmer Mode	OFF			Linear dimmer
	DIM1–4			Dimming curves DIM1 (fast) to DIM4 (slow)
LED Frequency	1200Hz			Sets the PWM frequency
	2000Hz			
	2400Hz			
	4000Hz			
	6000Hz			
	25000Hz			
Cell Order	1 - 15(Left to Right)			Sets order of cells
	15 - 1(Right to Left)			
Settings	**** (Enter Passcode)	DMX Error/ Loss	Hold Last	Continues last command upon loss of DMX
			Blackout	Blacks out product upon loss of DMX
	Disp TimeOut	On	Display backlight always on	
		10s	Turns off display backlight after 10 seconds of inactivity	
		20s	Turns off display backlight after 20 seconds of inactivity	
		30s	Turns off display backlight after 30 seconds of inactivity	
	Disp Passcode	On	Locks display (passcode is <UP>, <DOWN>, <UP>, <DOWN>, <ENTER>)	
		Off		
Information	Fixture Hours		___ Hours	Shows total number of hours the product has been powered on
	Firmware Version		V_ _	Shows current firmware version
	RDM	UID Label	----- Batten Q15	Shows product UID Shows RDM label
Factory Reset	No		**** (Enter Passcode)	Resets the product to factory default settings
	Yes			

Operation

Configuration (DMX)

Use control configurations to operate the product with a DMX controller.

Control Personalities

To set the control personality:

1. Go to the **Personality** main level.
2. Select the desired personality (see table below)

Personality	Channels	Cells
1 Simple	4	1
1 Basic	8	
1 Advanced	10	
1 HSIC	6	
15 Pixel	45	15
15 Simple	60	
15 Basic	64	
15 Advanced	66	
15 HSIC	76	



- See the [Starting Address](#) section for the highest starting address you can select for each personality.
- Make sure that the starting addresses on the various products do not overlap due to the new personality setting.

Starting Address

Each product will respond to a unique starting address from the controller. All products with the same starting address will respond in unison. To set the starting address:

1. Go to the **Start Address** main level.
2. Select the starting address (**1–509**).

The highest recommended starting address for each DMX mode is as follows:

Personality	Address
1 Simple	509
1 Basic	505
1 Advanced	503
1 HSIC	507
15 Pixel	465
15 Simple	453
15 Basic	449
15 Advanced	447
15 HSIC	437

Control Channel Assignments and Values

Color Macro Chart

Channel Value	Red Value	Green Value	Blue Value	White Value
000 ⇔ 010	No function	No function	No function	No function
011 ⇔ 034	100%	0–100%	0%	0%
035 ⇔ 059	100–0%	100%	0%	0%
060 ⇔ 084	0%	100%	0–100%	0%
085 ⇔ 109	0%	100–0%	100%	0%
110 ⇔ 134	0–100%	0%	100%	0%
135 ⇔ 159	100%	0%	100–0%	0%
160 ⇔ 184	100%	0–100%	0–100%	0%
185 ⇔ 209	100–0%	100–0%	100%	0%
210 ⇔ 255	100%	100%	100%	100%

Color Temperature Chart

Channel Value	Color Temperature
000 ⇔ 010	No function
011 ⇔ 028	1800K
029 ⇔ 046	2200K
047 ⇔ 064	2700K
065 ⇔ 082	3000K
083 ⇔ 100	3200K
101 ⇔ 118	3500K
119 ⇔ 136	4000K
137 ⇔ 154	4200K
155 ⇔ 172	4500K
173 ⇔ 190	5600K
191 ⇔ 208	6000K
209 ⇔ 226	6500K
227 ⇔ 244	7200K
245 ⇔ 255	8000K



The color temperatures above are simulated renditions of the color output produced as compared to a tungsten lamp at the specified color temperature. Chauvet makes no guarantee of the color output accuracy.

15-Cell DMX Values

15 HSIC (76 Channels)

Channel	Function	Value	Percent/Setting
1	Dimmer 1	000 ⇔ 255	0–100%
2	Hue 1	000 ⇔ 255	0–100%
3	Fine Hue 1	000 ⇔ 255	0–100%
4	Saturation 1	000 ⇔ 255	0–100%
5	Strobe 1	000 ⇔ 009	No function
		010 ⇔ 099	Strobe, slow to fast
		100 ⇔ 109	No function
		110 ⇔ 179	Lightning effect, slow to fast
		180 ⇔ 189	No function
		190 ⇔ 255	Random strobe, slow to fast
6	Dimmer 2	000 ⇔ 255	0–100%
7	Hue 2	000 ⇔ 255	0–100%
8	Fine Hue 2	000 ⇔ 255	0–100%
9	Saturation 2	000 ⇔ 255	0–100%

Operation

Channel	Function	Value	Percent/Setting
10	Strobe 2	000 ⇄ 009	No function
		010 ⇄ 099	Strobe, slow to fast
		100 ⇄ 109	No function
		110 ⇄ 179	Lightning effect, slow to fast
		180 ⇄ 189	No function
		190 ⇄ 255	Random strobe, slow to fast
11	Dimmer 3	000 ⇄ 255	0–100%
12	Hue 3	000 ⇄ 255	0–100%
13	Fine Hue 3	000 ⇄ 255	0–100%
14	Saturation 3	000 ⇄ 255	0–100%
15	Strobe 3	000 ⇄ 009	No function
		010 ⇄ 099	Strobe, slow to fast
		100 ⇄ 109	No function
		110 ⇄ 179	Lightning effect, slow to fast
		180 ⇄ 189	No function
		190 ⇄ 255	Random strobe, slow to fast
16	Dimmer 4	000 ⇄ 255	0–100%
17	Hue 4	000 ⇄ 255	0–100%
18	Fine Hue 4	000 ⇄ 255	0–100%
19	Saturation 4	000 ⇄ 255	0–100%
20	Strobe 4	000 ⇄ 009	No function
		010 ⇄ 099	Strobe, slow to fast
		100 ⇄ 109	No function
		110 ⇄ 179	Lightning effect, slow to fast
		180 ⇄ 189	No function
		190 ⇄ 255	Random strobe, slow to fast
21	Dimmer 5	000 ⇄ 255	0–100%
22	Hue 5	000 ⇄ 255	0–100%
23	Fine Hue 5	000 ⇄ 255	0–100%
24	Saturation 5	000 ⇄ 255	0–100%
25	Strobe 5	000 ⇄ 009	No function
		010 ⇄ 099	Strobe, slow to fast
		100 ⇄ 109	No function
		110 ⇄ 179	Lightning effect, slow to fast
		180 ⇄ 189	No function
		190 ⇄ 255	Random strobe, slow to fast
26	Dimmer 6	000 ⇄ 255	0–100%
27	Hue 6	000 ⇄ 255	0–100%
28	Fine Hue 6	000 ⇄ 255	0–100%
29	Saturation 6	000 ⇄ 255	0–100%
30	Strobe 6	000 ⇄ 009	No function
		010 ⇄ 099	Strobe, slow to fast
		100 ⇄ 109	No function
		110 ⇄ 179	Lightning effect, slow to fast
		180 ⇄ 189	No function
		190 ⇄ 255	Random strobe, slow to fast
31	Dimmer 7	000 ⇄ 255	0–100%
32	Hue 7	000 ⇄ 255	0–100%
33	Fine Hue 7	000 ⇄ 255	0–100%
34	Saturation 7	000 ⇄ 255	0–100%

Channel	Function	Value	Percent/Setting
35	Strobe 7	000 ⇄ 009	No function
		010 ⇄ 099	Strobe, slow to fast
		100 ⇄ 109	No function
		110 ⇄ 179	Lightning effect, slow to fast
		180 ⇄ 189	No function
		190 ⇄ 255	Random strobe, slow to fast
36	Dimmer 8	000 ⇄ 255	0–100%
37	Hue 8	000 ⇄ 255	0–100%
38	Fine Hue 8	000 ⇄ 255	0–100%
39	Saturation 8	000 ⇄ 255	0–100%
40	Strobe 8	000 ⇄ 009	No function
		010 ⇄ 099	Strobe, slow to fast
		100 ⇄ 109	No function
		110 ⇄ 179	Lightning effect, slow to fast
		180 ⇄ 189	No function
		190 ⇄ 255	Random strobe, slow to fast
41	Dimmer 9	000 ⇄ 255	0–100%
42	Hue 9	000 ⇄ 255	0–100%
43	Fine Hue 9	000 ⇄ 255	0–100%
44	Saturation 9	000 ⇄ 255	0–100%
45	Strobe 9	000 ⇄ 009	No function
		010 ⇄ 099	Strobe, slow to fast
		100 ⇄ 109	No function
		110 ⇄ 179	Lightning effect, slow to fast
		180 ⇄ 189	No function
		190 ⇄ 255	Random strobe, slow to fast
46	Dimmer 10	000 ⇄ 255	0–100%
47	Hue 10	000 ⇄ 255	0–100%
48	Fine Hue 10	000 ⇄ 255	0–100%
49	Saturation 10	000 ⇄ 255	0–100%
50	Strobe 10	000 ⇄ 009	No function
		010 ⇄ 099	Strobe, slow to fast
		100 ⇄ 109	No function
		110 ⇄ 179	Lightning effect, slow to fast
		180 ⇄ 189	No function
		190 ⇄ 255	Random strobe, slow to fast
51	Dimmer 11	000 ⇄ 255	0–100%
52	Hue 11	000 ⇄ 255	0–100%
53	Fine Hue 11	000 ⇄ 255	0–100%
54	Saturation 11	000 ⇄ 255	0–100%
55	Strobe 11	000 ⇄ 009	No function
		010 ⇄ 099	Strobe, slow to fast
		100 ⇄ 109	No function
		110 ⇄ 179	Lightning effect, slow to fast
		180 ⇄ 189	No function
		190 ⇄ 255	Random strobe, slow to fast
56	Dimmer 12	000 ⇄ 255	0–100%
57	Hue 12	000 ⇄ 255	0–100%
58	Fine Hue 12	000 ⇄ 255	0–100%
59	Saturation 12	000 ⇄ 255	0–100%

Operation

Channel	Function	Value	Percent/Setting
60	Strobe 12	000 ⇄ 009	No function
		010 ⇄ 099	Strobe, slow to fast
		100 ⇄ 109	No function
		110 ⇄ 179	Lightning effect, slow to fast
		180 ⇄ 189	No function
		190 ⇄ 255	Random strobe, slow to fast
61	Dimmer 13	000 ⇄ 255	0–100%
62	Hue 13	000 ⇄ 255	0–100%
63	Fine Hue 13	000 ⇄ 255	0–100%
64	Saturation 13	000 ⇄ 255	0–100%
65	Strobe 13	000 ⇄ 009	No function
		010 ⇄ 099	Strobe, slow to fast
		100 ⇄ 109	No function
		110 ⇄ 179	Lightning effect, slow to fast
		180 ⇄ 189	No function
		190 ⇄ 255	Random strobe, slow to fast
66	Dimmer 14	000 ⇄ 255	0–100%
67	Hue 14	000 ⇄ 255	0–100%
68	Fine Hue 14	000 ⇄ 255	0–100%
69	Saturation 14	000 ⇄ 255	0–100%
70	Strobe 14	000 ⇄ 009	No function
		010 ⇄ 099	Strobe, slow to fast
		100 ⇄ 109	No function
		110 ⇄ 179	Lightning effect, slow to fast
		180 ⇄ 189	No function
		190 ⇄ 255	Random strobe, slow to fast
71	Dimmer 15	000 ⇄ 255	0–100%
72	Hue 15	000 ⇄ 255	0–100%
73	Fine Hue 15	000 ⇄ 255	0–100%
74	Saturation 15	000 ⇄ 255	0–100%
75	Strobe 15	000 ⇄ 009	No function
		010 ⇄ 099	Strobe, slow to fast
		100 ⇄ 109	No function
		110 ⇄ 179	Lightning effect, slow to fast
		180 ⇄ 189	No function
		190 ⇄ 255	Random strobe, slow to fast
76	Dimmer Speed	000 ⇄ 009	Preset dimmer speed from display menu
		010 ⇄ 029	Dimmer speed mode off
		030 ⇄ 069	Dimmer speed mode 1 (fastest)
		070 ⇄ 129	Dimmer speed mode 2
		130 ⇄ 189	Dimmer speed mode 3
		190 ⇄ 255	Dimmer speed mode 4 (slowest)

15 Advanced (66 Channels)

Channel	Function	Value	Percent/Setting
1	Dimmer	000 ⇄ 255	0–100%
2	Fine Dimmer	000 ⇄ 255	0–100%
3	Red 1	000 ⇄ 255	0–100%
4	Green 1	000 ⇄ 255	0–100%
5	Blue 1	000 ⇄ 255	0–100%
6	White 1	000 ⇄ 255	0–100%
7	Red 2	000 ⇄ 255	0–100%
8	Green 2	000 ⇄ 255	0–100%

Channel	Function	Value	Percent/Setting
9	Blue 2	000 ⇄ 255	0-100%
10	White 2	000 ⇄ 255	0-100%
11	Red 3	000 ⇄ 255	0-100%
12	Green 3	000 ⇄ 255	0-100%
13	Blue 3	000 ⇄ 255	0-100%
14	White 3	000 ⇄ 255	0-100%
15	Red 4	000 ⇄ 255	0-100%
16	Green 4	000 ⇄ 255	0-100%
17	Blue 4	000 ⇄ 255	0-100%
18	White 4	000 ⇄ 255	0-100%
19	Red 5	000 ⇄ 255	0-100%
20	Green 5	000 ⇄ 255	0-100%
21	Blue 5	000 ⇄ 255	0-100%
22	White 5	000 ⇄ 255	0-100%
23	Red 6	000 ⇄ 255	0-100%
24	Green 6	000 ⇄ 255	0-100%
25	Blue 6	000 ⇄ 255	0-100%
26	White 6	000 ⇄ 255	0-100%
27	Red 7	000 ⇄ 255	0-100%
28	Green 7	000 ⇄ 255	0-100%
29	Blue 7	000 ⇄ 255	0-100%
30	White 7	000 ⇄ 255	0-100%
31	Red 8	000 ⇄ 255	0-100%
32	Green 8	000 ⇄ 255	0-100%
33	Blue 8	000 ⇄ 255	0-100%
34	White 8	000 ⇄ 255	0-100%
35	Red 9	000 ⇄ 255	0-100%
36	Green 9	000 ⇄ 255	0-100%
37	Blue 9	000 ⇄ 255	0-100%
38	White 9	000 ⇄ 255	0-100%
39	Red 10	000 ⇄ 255	0-100%
40	Green 10	000 ⇄ 255	0-100%
41	Blue 10	000 ⇄ 255	0-100%
42	White 10	000 ⇄ 255	0-100%
43	Red 11	000 ⇄ 255	0-100%
44	Green 11	000 ⇄ 255	0-100%
45	Blue 11	000 ⇄ 255	0-100%
46	White 11	000 ⇄ 255	0-100%
47	Red 12	000 ⇄ 255	0-100%
48	Green 12	000 ⇄ 255	0-100%
49	Blue 12	000 ⇄ 255	0-100%
50	White 12	000 ⇄ 255	0-100%
51	Red 13	000 ⇄ 255	0-100%
52	Green 13	000 ⇄ 255	0-100%
53	Blue 13	000 ⇄ 255	0-100%
54	White 13	000 ⇄ 255	0-100%
55	Red 14	000 ⇄ 255	0-100%
56	Green 14	000 ⇄ 255	0-100%
57	Blue 14	000 ⇄ 255	0-100%
58	White 14	000 ⇄ 255	0-100%
59	Red 15	000 ⇄ 255	0-100%
60	Green 15	000 ⇄ 255	0-100%
61	Blue 15	000 ⇄ 255	0-100%
62	White 15	000 ⇄ 255	0-100%

Operation

Channel	Function	Value	Percent/Setting
63	Color Macros	000 ⇄ 255	See Color Macro Chart
64	Color Temperatures	000 ⇄ 255	See Color Temperature Chart
65	Strobe	000 ⇄ 009	No function
		010 ⇄ 099	Strobe, slow to fast
		100 ⇄ 109	No function
		110 ⇄ 179	Lightning effect, slow to fast
		180 ⇄ 189	No function
		190 ⇄ 255	Random strobe, slow to fast
66	Dimmer Speed	000 ⇄ 009	Preset dimmer speed from display menu
		010 ⇄ 029	Dimmer speed mode off
		030 ⇄ 069	Dimmer speed mode 1 (fastest)
		070 ⇄ 129	Dimmer speed mode 2
		130 ⇄ 189	Dimmer speed mode 3
		190 ⇄ 255	Dimmer speed mode 4 (slowest)

15 Basic (64 Channels)

Channel	Function	Value	Percent/Setting
1	Dimmer	000 ⇄ 255	0–100%
2	Fine Dimmer	000 ⇄ 255	0–100%
3	Red 1	000 ⇄ 255	0–100%
4	Green 1	000 ⇄ 255	0–100%
5	Blue 1	000 ⇄ 255	0–100%
6	White 1	000 ⇄ 255	0–100%
7	Red 2	000 ⇄ 255	0–100%
8	Green 2	000 ⇄ 255	0–100%
9	Blue 2	000 ⇄ 255	0–100%
10	White 2	000 ⇄ 255	0–100%
11	Red 3	000 ⇄ 255	0–100%
12	Green 3	000 ⇄ 255	0–100%
13	Blue 3	000 ⇄ 255	0–100%
14	White 3	000 ⇄ 255	0–100%
15	Red 4	000 ⇄ 255	0–100%
16	Green 4	000 ⇄ 255	0–100%
17	Blue 4	000 ⇄ 255	0–100%
18	White 4	000 ⇄ 255	0–100%
19	Red 5	000 ⇄ 255	0–100%
20	Green 5	000 ⇄ 255	0–100%
21	Blue 5	000 ⇄ 255	0–100%
22	White 5	000 ⇄ 255	0–100%
23	Red 6	000 ⇄ 255	0–100%
24	Green 6	000 ⇄ 255	0–100%
25	Blue 6	000 ⇄ 255	0–100%
26	White 6	000 ⇄ 255	0–100%
27	Red 7	000 ⇄ 255	0–100%
28	Green 7	000 ⇄ 255	0–100%
29	Blue 7	000 ⇄ 255	0–100%
30	White 7	000 ⇄ 255	0–100%
31	Red 8	000 ⇄ 255	0–100%
32	Green 8	000 ⇄ 255	0–100%
33	Blue 8	000 ⇄ 255	0–100%
34	White 8	000 ⇄ 255	0–100%
35	Red 9	000 ⇄ 255	0–100%
36	Green 9	000 ⇄ 255	0–100%

Channel	Function	Value	Percent/Setting
37	Blue 9	000 ⇄ 255	0–100%
38	White 9	000 ⇄ 255	0–100%
39	Red 10	000 ⇄ 255	0–100%
40	Green 10	000 ⇄ 255	0–100%
41	Blue 10	000 ⇄ 255	0–100%
42	White 10	000 ⇄ 255	0–100%
43	Red 11	000 ⇄ 255	0–100%
44	Green 11	000 ⇄ 255	0–100%
45	Blue 11	000 ⇄ 255	0–100%
46	White 11	000 ⇄ 255	0–100%
47	Red 12	000 ⇄ 255	0–100%
48	Green 12	000 ⇄ 255	0–100%
49	Blue 12	000 ⇄ 255	0–100%
50	White 12	000 ⇄ 255	0–100%
51	Red 13	000 ⇄ 255	0–100%
52	Green 13	000 ⇄ 255	0–100%
53	Blue 13	000 ⇄ 255	0–100%
54	White 13	000 ⇄ 255	0–100%
55	Red 14	000 ⇄ 255	0–100%
56	Green 14	000 ⇄ 255	0–100%
57	Blue 14	000 ⇄ 255	0–100%
58	White 14	000 ⇄ 255	0–100%
59	Red 15	000 ⇄ 255	0–100%
60	Green 15	000 ⇄ 255	0–100%
61	Blue 15	000 ⇄ 255	0–100%
62	White 15	000 ⇄ 255	0–100%
63	Color Macros	000 ⇄ 255	See Color Macro Chart
64	Strobe	000 ⇄ 009	No function
		010 ⇄ 099	Strobe, slow to fast
		100 ⇄ 109	No function
		110 ⇄ 179	Lightning effect, slow to fast
		180 ⇄ 189	No function
		190 ⇄ 255	Random strobe, slow to fast

15 Simple (60 Channels)

Channel	Function	Value	Percent/Setting
1	Red 1	000 ⇄ 255	0–100%
2	Green 1	000 ⇄ 255	0–100%
3	Blue 1	000 ⇄ 255	0–100%
4	White 1	000 ⇄ 255	0–100%
5	Red 2	000 ⇄ 255	0–100%
6	Green 2	000 ⇄ 255	0–100%
7	Blue 2	000 ⇄ 255	0–100%
8	White 2	000 ⇄ 255	0–100%
9	Red 3	000 ⇄ 255	0–100%
10	Green 3	000 ⇄ 255	0–100%
11	Blue 3	000 ⇄ 255	0–100%
12	White 3	000 ⇄ 255	0–100%
13	Red 4	000 ⇄ 255	0–100%
14	Green 4	000 ⇄ 255	0–100%
15	Blue 4	000 ⇄ 255	0–100%
16	White 4	000 ⇄ 255	0–100%
17	Red 5	000 ⇄ 255	0–100%

Operation

Channel	Function	Value	Percent/Setting
18	Green 5	000 ⇄ 255	0–100%
19	Blue 5	000 ⇄ 255	0–100%
20	White 5	000 ⇄ 255	0–100%
21	Red 6	000 ⇄ 255	0–100%
22	Green 6	000 ⇄ 255	0–100%
23	Blue 6	000 ⇄ 255	0–100%
24	White 6	000 ⇄ 255	0–100%
25	Red 7	000 ⇄ 255	0–100%
26	Green 7	000 ⇄ 255	0–100%
27	Blue 7	000 ⇄ 255	0–100%
28	White 7	000 ⇄ 255	0–100%
29	Red 8	000 ⇄ 255	0–100%
30	Green 8	000 ⇄ 255	0–100%
31	Blue 8	000 ⇄ 255	0–100%
32	White 8	000 ⇄ 255	0–100%
33	Red 9	000 ⇄ 255	0–100%
34	Green 9	000 ⇄ 255	0–100%
35	Blue 9	000 ⇄ 255	0–100%
36	White 9	000 ⇄ 255	0–100%
37	Red 10	000 ⇄ 255	0–100%
38	Green 10	000 ⇄ 255	0–100%
39	Blue 10	000 ⇄ 255	0–100%
40	White 10	000 ⇄ 255	0–100%
41	Red 11	000 ⇄ 255	0–100%
42	Green 11	000 ⇄ 255	0–100%
43	Blue 11	000 ⇄ 255	0–100%
44	White 11	000 ⇄ 255	0–100%
45	Red 12	000 ⇄ 255	0–100%
46	Green 12	000 ⇄ 255	0–100%
47	Blue 12	000 ⇄ 255	0–100%
48	White 12	000 ⇄ 255	0–100%
49	Red 13	000 ⇄ 255	0–100%
50	Green 13	000 ⇄ 255	0–100%
51	Blue 13	000 ⇄ 255	0–100%
52	White 13	000 ⇄ 255	0–100%
53	Red 14	000 ⇄ 255	0–100%
54	Green 14	000 ⇄ 255	0–100%
55	Blue 14	000 ⇄ 255	0–100%
56	White 14	000 ⇄ 255	0–100%
57	Red 15	000 ⇄ 255	0–100%
58	Green 15	000 ⇄ 255	0–100%
59	Blue 15	000 ⇄ 255	0–100%
60	White 15	000 ⇄ 255	0–100%

15 Pixel (45 Channels)

Channel	Function	Value	Percent/Setting
1	Red 1	000 ⇄ 255	0–100%
2	Green 1	000 ⇄ 255	0–100%
3	Blue 1	000 ⇄ 255	0–100%
4	Red 2	000 ⇄ 255	0–100%
5	Green 2	000 ⇄ 255	0–100%
6	Blue 2	000 ⇄ 255	0–100%
7	Red 3	000 ⇄ 255	0–100%

Channel	Function	Value	Percent/Setting
8	Green 3	000 ⇄ 255	0–100%
9	Blue 3	000 ⇄ 255	0–100%
10	Red 4	000 ⇄ 255	0–100%
11	Green 4	000 ⇄ 255	0–100%
12	Blue 4	000 ⇄ 255	0–100%
13	Red 5	000 ⇄ 255	0–100%
14	Green 5	000 ⇄ 255	0–100%
15	Blue 5	000 ⇄ 255	0–100%
16	Red 6	000 ⇄ 255	0–100%
17	Green 6	000 ⇄ 255	0–100%
18	Blue 6	000 ⇄ 255	0–100%
19	Red 7	000 ⇄ 255	0–100%
20	Green 7	000 ⇄ 255	0–100%
21	Blue 7	000 ⇄ 255	0–100%
22	Red 8	000 ⇄ 255	0–100%
23	Green 8	000 ⇄ 255	0–100%
24	Blue 8	000 ⇄ 255	0–100%
25	Red 9	000 ⇄ 255	0–100%
26	Green 9	000 ⇄ 255	0–100%
27	Blue 9	000 ⇄ 255	0–100%
28	Red 10	000 ⇄ 255	0–100%
29	Green 10	000 ⇄ 255	0–100%
30	Blue 10	000 ⇄ 255	0–100%
31	Red 11	000 ⇄ 255	0–100%
32	Green 11	000 ⇄ 255	0–100%
33	Blue 11	000 ⇄ 255	0–100%
34	Red 12	000 ⇄ 255	0–100%
35	Green 12	000 ⇄ 255	0–100%
36	Blue 12	000 ⇄ 255	0–100%
37	Red 13	000 ⇄ 255	0–100%
38	Green 13	000 ⇄ 255	0–100%
39	Blue 13	000 ⇄ 255	0–100%
40	Red 14	000 ⇄ 255	0–100%
41	Green 14	000 ⇄ 255	0–100%
42	Blue 14	000 ⇄ 255	0–100%
43	Red 15	000 ⇄ 255	0–100%
44	Green 15	000 ⇄ 255	0–100%
45	Blue 15	000 ⇄ 255	0–100%

1-Cell DMX Values

1 HSIC (6 Channels)

Channel	Function	Value	Percent/Setting
1	Dimmer	000 ⇄ 255	0–100%
2	Hue	000 ⇄ 255	0–100%
3	Fine Hue	000 ⇄ 255	0–100%
4	Saturation	000 ⇄ 255	0–100%
5	Strobe	000 ⇄ 009	No function
		010 ⇄ 099	Strobe, slow to fast
		100 ⇄ 109	No function
		110 ⇄ 179	Lightning effect, slow to fast
		180 ⇄ 189	No function
		190 ⇄ 255	Random strobe, slow to fast

Operation

Channel	Function	Value	Percent/Setting
6	Dimmer Speed	000 ⇔ 009	Preset dimmer speed from display menu
		010 ⇔ 029	Dimmer speed mode off
		030 ⇔ 069	Dimmer speed mode 1 (fastest)
		070 ⇔ 129	Dimmer speed mode 2
		130 ⇔ 189	Dimmer speed mode 3
		190 ⇔ 255	Dimmer speed mode 4 (slowest)

1 Advanced (10 Channels)

Channel	Function	Value	Percent/Setting
1	Dimmer	000 ⇔ 255	0–100%
2	Fine Dimmer	000 ⇔ 255	0–100%
3	Red	000 ⇔ 255	0–100%
4	Green	000 ⇔ 255	0–100%
5	Blue	000 ⇔ 255	0–100%
6	White	000 ⇔ 255	0–100%
7	Color Macros	000 ⇔ 255	See Color Macro Chart
8	Color Temperatures	000 ⇔ 255	See Color Temperature Chart
9	Strobe	000 ⇔ 009	No function
		010 ⇔ 099	Strobe, slow to fast
		100 ⇔ 109	No function
		110 ⇔ 179	Lightning effect, slow to fast
		180 ⇔ 189	No function
		190 ⇔ 255	Random strobe, slow to fast
10	Dimmer Speed	000 ⇔ 009	Preset dimmer speed from display menu
		010 ⇔ 029	Dimmer speed mode off
		030 ⇔ 069	Dimmer speed mode 1 (fastest)
		070 ⇔ 129	Dimmer speed mode 2
		130 ⇔ 189	Dimmer speed mode 3
		190 ⇔ 255	Dimmer speed mode 4 (slowest)

1 Basic (8 Channels)

Channel	Function	Value	Percent/Setting
1	Dimmer	000 ⇔ 255	0–100%
2	Fine Dimmer	000 ⇔ 255	0–100%
3	Red	000 ⇔ 255	0–100%
4	Green	000 ⇔ 255	0–100%
5	Blue	000 ⇔ 255	0–100%
6	White	000 ⇔ 255	0–100%
7	Color Macros	000 ⇔ 255	See Color Macro Chart
8	Strobe	000 ⇔ 009	No function
		010 ⇔ 099	Strobe, slow to fast
		100 ⇔ 109	No function
		110 ⇔ 179	Lightning effect, slow to fast
		180 ⇔ 189	No function
		190 ⇔ 255	Random strobe, slow to fast

1 Simple (4 Channels)

Channel	Function	Value	Percent/Setting
1	Red	000 ⇔ 255	0–100%
2	Green	000 ⇔ 255	0–100%
3	Blue	000 ⇔ 255	0–100%
4	White	000 ⇔ 255	0–100%

Configuration (Standalone)

Static Colors

The static color modes allows for an unchanging color without a DMX controller.

Preset Colors

1. Go to the **Static Colors** main level.
2. Select the **Preset Colors** option.
3. Select from **Color 1–14**.
4. Increase or decrease the dimmer value from **0–100%**.

Preset Color Temperatures

1. Go to the **Static Colors** main level.
2. Select the **CCT Temper** option.
3. Select from **White 1–14**.
4. Increase or decrease the dimmer value from **0–100%**.

Custom Color Mixing

1. Go to the **Static Colors** main level.
2. Select the **RGBW** option.
3. Select which color value to edit, from **Red, Green, Blue, or White**.
4. Increase or decrease the value of the selected color from **0–255**.

Automatic Programs

The COLORado Batten Q15 has preset automatic programs and customizable programs.

Run Program

1. Go to the **Auto Programs** main level.
2. Select the **Run** option.
3. Select from **AUTO.1–10** (preset programs) or **Program 1–10** (customizable programs).
4. Increase or decrease the **SPEED** from **0–100%**.

Customize Program

1. Go to the **Auto Programs** main level.
2. Select the **Edit** option.
3. Select from **Program 1–10**.
4. Select from **Scene 01–30**.
5. Select which color value to edit, from **Red, Green, Blue, or White**.
6. Increase or decrease the value of the selected color from **0–255**.

Configuration (Settings)

Output Setting

To select how the product keeps from going over the maximum temperature:

1. Go to the **Output Setting** main level.
2. Select from **Power Mode** (adjusts output as temperature increases) or **Steady Mode** (maintains a lower output to keep temperature steady).

Master/Slave

The Master/Slave mode allows a group of COLORado Batten Q15 products (the slaves) to simultaneously duplicate the output of another COLORado Batten Q15 (the master) without a DMX controller. To set each of the slaves:

1. Go to the **Master/Slave** main level.
2. Select **Slave**.

To set the master:

1. Go to the **Master/Slave** main level.
2. Select **Master**.
3. Select a standalone setting.



- The master is the one that runs a program whether in Auto or Static mode.
- Do not connect a DMX controller to the products configured for Master/Slave operation. The DMX controller may interfere with signals from the master.
- The master should be the first product in the daisy chain.

Operation

Dimmer Mode

This setting determines how fast the output of the COLORado Batten Q15 changes when you modify the output value. This setting provides four different options to simulate the dimming curve of an incandescent lighting product.

1. Go to the **Dimmer Mode** main level.
2. Select a dimmer curve (**OFF**, **DIM1**, **DIM2**, **DIM3**, or **DIM4**).



OFF: The output is proportional (linear) to the dimmer channel value.

DIM1-4: The output follows the dimmer value based on the corresponding dimmer curve, DIM1 being the fastest.

Pulse Width Modulation

To set the PWM frequency:

1. Go to the **LED Frequency** main level.
2. Select the frequency, from **1200Hz**, **2000Hz**, **2400Hz**, **4000Hz**, **6000Hz**, or **25000Hz**.

Cell Order

To set the cell order:

1. Go to the **Cell Order** main level.
2. Select the direction from **1 - 15(Left to Right)** or **15 - 1(Right to Left)**.

DMX Error/Loss

To select what happens when a DMX signal is lost:

1. Go to the **Settings** main level.
2. Enter the passcode (<UP>, <DOWN>, <UP>, <DOWN>, <ENTER>).
3. Select the **DMX Error/Loss** option.
4. Select from **Hold Last** (continues last command) or **Blackout** (blacks out).

Display Timeout

To set the duration of inactivity before the display turns off:

1. Go to the **Settings** main level.
2. Enter the passcode (<UP>, <DOWN>, <UP>, <DOWN>, <ENTER>).
3. Select the **Disp TimeOut** option.
4. Select from **On** (display always on), **10s** (10 seconds), **20s** (20 seconds), or **30s** (30 seconds).

Display Passcode

To enable or disable to passcode lock:

1. Go to the **Settings** main level.
2. Enter the passcode (<UP>, <DOWN>, <UP>, <DOWN>, <ENTER>).
3. Select the **Disp Passcode** option.
4. Select from **On** (display locked) or **Off** (display unlocked).

Product Information

To view the product information:

1. Go to the **Information** main level.
2. Select from **Fixture Hours**, **Firmware Version**, or **RDM**.

Factory Reset

To reset the product to factory default settings:

1. Go to the **Factory Reset** main level.
2. Select from **No** (do not reset) or **Yes** (reset the product).
3. Enter the passcode (<UP>, <DOWN>, <UP>, <DOWN>, <ENTER>).

5. Maintenance

Product Maintenance

Dust build-up reduces light output performance and can cause overheating. This can lead to reduction of the light source's life and/or mechanical wear. To maintain optimum performance and minimize wear, clean your lighting products at least twice a month. However, be aware that usage and environmental conditions could be contributing factors to increase the cleaning frequency.

To clean the product, follow the instructions below:

1. Unplug the product from power.
2. Wait until the product is at room temperature.
3. Use a vacuum (or dry compressed air) and a soft brush to remove dust collected on the external surface/vents.
4. Clean all transparent surfaces with a mild soap solution, ammonia-free glass cleaner, or isopropyl alcohol.
5. Apply the solution directly to a soft, lint free cotton cloth or a lens cleaning tissue.
6. Softly drag any dirt or grime to the outside of the transparent surface.
7. Gently polish the transparent surfaces until they are free of haze and lint.



Always dry the transparent surfaces carefully after cleaning them.

Technical Specifications

6. Technical Specifications

Dimensions and Weight

Length	Width	Height	Weight
41.22 in (1047 mm)	7.28 in (185 mm)	6.55 in (166.4 mm)	28.8 lb (13 kg)

Note: Dimensions in inches are rounded.

Power

Power Supply Type	Range	Voltage Selection
Switching (internal)	100 to 240 VAC, 50/60 Hz	Auto-ranging

Parameter	100 V, 60 Hz	120 V, 60 Hz	208 V, 60 Hz	230 V, 50 Hz	240 V, 50 Hz
Consumption	195 W	194 W	197 W	197 W	197 W
Operating Current	1.958 A	1.606 A	0.951 A	0.860 A	0.826 A
Power linking current (products)	13.6 A (6 products)	13.6 A (8 products)	13.6 A (14 products)	13.6 A (15 products)	13.6 A (16 products)

Power I/O	U.S./Worldwide	UK/Europe
Power Input Connector	Seetronic Powerkon IP65	Seetronic Powerkon IP65
Power Output Connector	Seetronic Powerkon IP65	Seetronic Powerkon IP65
Power Cord plug	Edison (U.S.)	Local Plug

Light Source

Type	Color	Quantity	Power	Current	Lifespan
LED	Quad-color RGBW	15	20 W	800 mA	50,000 hours

Photometrics

Filter Status	Horizontal Beam Angle	Vertical Beam Angle	Horizontal Field Angle	Vertical Field Angle
With Filter	15.5°	14.7°	28.6°	28.1°
Without Filter	41.9°	15.3°	77.9°	32.1°

Installed Optics	Illuminance @ 5 m (without filter)	Illuminance @ 5 m (With filter)
16°	2,399 lux	653 lux

Thermal

Minimum External Temperature	Maximum External Temperature	Cooling System
-4 °F (-20 °C)	113 °F (45 °C)	Convection

DMX

I/O Connector	Channel Range
5-pin XLR	1 Cell: 4, 6, 8, 10; 15 Cell: 45, 60, 64, 66, 76

Ordering

Product Name	Item Name	Item Code	UPC Number
COLORado Batten Q15	COLORADOBATTENQ15	01031582	781462219307



UL 1573
CSA C22.2 No. 166
E113093



RoHS



Returns

Send the product prepaid, in the original box, and with the original packing and accessories. Chauvet will not issue call tags.

Call Chauvet and request a Return Merchandise Authorization (RMA) number before shipping the product. Be prepared to provide the model number, serial number, and a brief description of the cause(s) for the return.

To submit a service request online, go to www.chauvetprofessional.com/service-request.

Clearly label the package with an RMA number. Chauvet will refuse any product returned without an RMA number.



Write the RMA number on a properly affixed label. DO NOT write the RMA number directly on the box.

Before sending the product, clearly write the following information on a piece of paper and place it inside the box:

- Your name
- Your address
- Your phone number
- RMA number
- A brief description of the problem

Be sure to pack the product properly. Any shipping damage resulting from inadequate packaging will be your responsibility. FedEx packing or double-boxing are recommended.



Chauvet reserves the right to use its own discretion to repair or replace returned product(s).

Contact Us

General Information	Technical Support
Chauvet World Headquarters	
Address: 5200 NW 108th Ave. Sunrise, FL 33351 Voice: (954) 577-4455 Fax: (954) 929-5560 Toll Free: (800) 762-1084	Voice: (844) 393-7575 Fax: (954) 756-8015 Email: chauvetcs@chauvetlighting.com Website: www.chauvetprofessional.com
Chauvet Europe Ltd	
Address: Unit 1C Brookhill Road Industrial Estate Pinxton, Nottingham, UK NG16 6NT Voice: +44 (0) 1773 511115 Fax: +44 (0) 1773 511110	Email: UKtech@chauvetlighting.eu Website: www.chauvetprofessional.eu
Chauvet Europe BVBA	
Address: Stokstraat 18 9770 Kruishoutem Belgium Voice: +32 9 388 93 97	Email: BNLtech@chauvetlighting.eu Website: www.chauvetprofessional.eu
Chauvet France	
Address: 3, Rue Ampère 91380 Chilly-Mazarin France Voice: +33 1 78 85 33 59	Email: FRtech@chauvetlighting.fr Website: www.chauvetprofessional.eu
Chauvet Germany	
Address: Bruno-Bürgerl-Str. 11 28759 Bremen Germany Voice: +49 421 62 60 20	Email: DEtech@chauvetlighting.de Website: www.chauvetprofessional.eu
Chauvet Mexico	
Address: Av. de las Partidas 34 - 3B (Entrance by Calle 2) Zona Industrial Lerma Lerma, Edo. de México, CP 52000 Voice: +52 (728) 690-2010	Email: servicio@chauvet.com.mx Website: www.chauvetprofessional.mx

Visit the applicable website above to verify our contact information and instructions to request support. Outside the U.S., U.K., Ireland, Benelux, France, Germany, or Mexico, contact the dealer of record.