



# **FUZE PENDANT™**

user manual

©2021 ELATION PROFESSIONAL all rights reserved. Information, specifications, diagrams, images, and instructions herein are subject to change without notice. ELATION PROFESSIONAL logo and identifying product names and numbers herein are trademarks of ELATION PROFESSIONAL. Copyright protection claimed includes all forms and matters of copyrightable materials and information now allowed by statutory or judicial law or hereinafter granted. Product names used in this document may be trademarks or registered trademarks of their respective companies and are hereby acknowledged. All non-ELATION brands and product names are trademarks or registered trademarks of their respective companies.

**ELATION PROFESSIONAL** and all affiliated companies hereby disclaim any and all liabilities for property, equipment, building, and electrical damages, injuries to any persons, and direct or indirect economic loss associated with the use or reliance of any information contained within this document, and/or as a result of the improper, unsafe, insufficient and negligent assembly, installation, rigging, and operation of this product.

**Elation Professional USA** | 6122 S. Eastern Ave. | Los Angeles, CA. 90040  
 323-582-3322 | 323-832-9142 fax | [www.elationlighting.com](http://www.elationlighting.com) | [info@elationlighting.com](mailto:info@elationlighting.com)

**Elation Professional B.V.** | Junostraat 2 | 6468 EW Kerkrade, The Netherlands  
 +31 45 546 85 66 | +31 45 546 85 96 fax | [www.elationlighting.eu](http://www.elationlighting.eu) | [info@elationlighting.eu](mailto:info@elationlighting.eu)

**Elation Professional Mexico** | AV Santa Ana 30 | Parque Industrial Lerma, Lerma, Mexico 52000  
 +52 (728) 282-7070

## DOCUMENT VERSION



Due to additional product enhancements, an updated version of this document may be available online. Please scan the QR Code with your mobile device or visit [www.elationlighting.com](http://www.elationlighting.com) for the latest revision/update of this manual before installation and/or programming.

Date	Document Version	Software Version ≥	DMX Channel Modes	Notes
01/16/20	1.0	1.01H	Dimmer1CH, Dimmer Color 4CH, RGBWL 5CH, RGBWL 16bit 10CH, Standard 10CH, Extended 17CH, HSI 4CH, HSI Extended 9CH	Preliminary release.
02/25/20	1.1	1.03	NO CHANGE	Updated overview and system menu.
04/06/20	1.2	NC	NO CHANGE	Updated Optional Accessories.
06/16/20	1.3	1.04	NO CHANGE	Updated System Menu.
08/24/20	1.4	1.06	NO CHANGE	Updated primary/secondary
09/24/20	1.5	NC	NO CHANGE	Updated dimensional drawings, specifications, accessory installation.
11/04/20	1.6	NC	NO CHANGE	Corrected error in DMX Ch. Functions.
03/09/21	1.7	NC	NO CHANGE	Updated Specifications.
09/20/21	1.8	NC	NO CHANGE	Updated Optional Accessories.

# CONTENTS

General Information	4
Warranty Returns (USA Only)	5
Safety Guidelines	6
Maintenance Guidelines	8
Overview	9
Optional Accessory Installation Guidelines	11
Fixture Installation Guidelines	18
E-FLY Wireless Set Up Guidelines	20
System Menu	21
Dimmer Modes	26
DMX Channel Functions	27
Color Temperature Table	36
Virtual Gel Swatch Book Table	37
Error Codes	38
Specifications	39
Dimensional Drawings	40
Optional Accessories   FCC Statement	45

# GENERAL INFORMATION

## INTRODUCTION

Please read and understand the instructions in this manual carefully and thoroughly before attempting to operate this fixture. These instructions contain important safety and use information.

## UNPACKING

Every fixture has been thoroughly tested and has been shipped in perfect operating condition. Carefully check the shipping carton for damage that may have occurred during shipping. If the carton is damaged, carefully inspect the fixture for damage, and be sure all accessories necessary to install and operate the fixture have arrived intact. In the event damage has been found or parts are missing, please contact our customer support team for further instructions. Please do not return this fixture to your dealer without first contacting customer support. Please do not discard the shipping carton in the trash. Please recycle whenever possible.

## BOX CONTENTS

45° Lens  
Pendant Bracket Kit  
Locking IP65 Power Cable

## CUSTOMER SUPPORT

Contact **ELATION Service** for any product related service and support needs. Also visit [forums.elationlighting.com](https://forums.elationlighting.com) with questions, comments or suggestions.

**ELATION SERVICE USA - Monday - Friday 8:00am to 4:30pm PST**  
323-582-3322 | Fax 323-832-9142 | [support@elationlighting.com](mailto:support@elationlighting.com)

**ELATION SERVICE EUROPE - Monday - Friday 08:30 to 17:00 CET**  
+31 45 546 85 63 | Fax +31 45 546 85 96 | [support@elationlighting.eu](mailto:support@elationlighting.eu)

**REPLACEMENT PARTS** please visit [parts.elationlighting.com](https://parts.elationlighting.com)



## **I M P O R T A N T   N O T I C E !**

**THERE ARE NO USER SERVICEABLE PARTS INSIDE THIS UNIT.**

**DO NOT ATTEMPT ANY REPAIRS YOURSELF; DOING SO WILL VOID YOUR MANUFACTURER'S WARRANTY. DAMAGES RESULTING FROM MODIFICATIONS TO THIS FIXTURE AND/OR THE DISREGARD OF SAFETY INSTRUCTIONS AND GUIDELINES IN THIS MANUAL VOID THE MANUFACTURER'S WARRANTY AND ARE NOT SUBJECT TO ANY WARRANTY CLAIMS AND/OR REPAIRS.**

## **WARRANTY RETURNS (USA ONLY)**

To obtain warranty service, a Return Materials Authorization (RMA) number must first be obtained from ELATION. It is the Customer's responsibility to provide product proof of purchase and serial number by acceptable evidence such as an invoice copy or an approved ELATION Extended Warranty Certificate ("EWC") and any relevant maintenance records at the time warranty service is sought. Failure to provide acceptable evidence of product proof of purchase or EWC and any relevant maintenance records may be cause for denial of warranty service.

Products returned for warranty service must be sent without any accessories (i.e., power, data, and safety cables, brackets, clamps, rigging hardware, frost filters, gel frames, barn doors, lens, hoses, nozzles, rack mounting hardware, etc.), must be boxed using the original and/or suitable packaging materials (double-box and foam) that provides ample product protection for ground and/or air freight transit, and must be shipped freight pre-paid and insured to ELATION in Los Angeles, CA or an ELATION Authorized Service Center. The RMA number must be clearly written on the outside of the return box, and a brief description of the problem and the RMA number must be documented and included in the box.

Products returned for warranty service without an RMA number clearly marked on the outside of the package will be refused and returned to the shipper at the Customer's expense. Products returned for warranty service, which are received damaged due to inadequate and/or improper packaging and/or due to damage caused by shipping carrier, may incur additional repair charges before warranty service begins and/or may void this warranty. If any product accessories (included and/or optional) are shipped with the product, ELATION and/or the ELATION Authorized Service Center shall have no liability what so ever for the loss and/or damage to any such accessories, nor the safe return thereof. If the requested warranty repairs or service (including parts replacement) are within the terms of this warranty, ELATION will pay return ground transportation shipping charges to a single designated point within the United States.

# SAFETY GUIDELINES

This fixture is a sophisticated piece of electronic equipment. To guarantee a smooth operation, it is important to follow all instructions and guidelines in this manual. Elation Professional is not responsible for injury and/or damages resulting from the misuse of this fixture due to the disregard of the information printed in this manual. Only qualified and/or certified personnel should perform installation of this fixture and only the original rigging and mounting hardware included with this fixture or available optional accessories should be used for installation. Any modifications to the fixture and/or the included and optional rigging and mounting hardware will void the original manufacturer's warranty and increase the risk of damage and/or personal injury.



## **PROTECTION CLASS 1 - FIXTURE MUST BE PROPERLY GROUNDED**



**THERE ARE NO USER SERVICEABLE PARTS INSIDE THIS UNIT. DO NOT ATTEMPT ANY REPAIRS YOURSELF; DOING SO WILL VOID YOUR MANUFACTURER'S WARRANTY. DAMAGES RESULTING FROM MODIFICATIONS TO THIS FIXTURE AND/OR THE DISREGARD OF SAFETY INSTRUCTIONS AND GUIDELINES IN THIS MANUAL VOID THE MANUFACTURER'S WARRANTY AND ARE NOT SUBJECT TO ANY WARRANTY CLAIMS AND/OR REPAIRS.**



**DO NOT PLUG FIXTURE INTO A DIMMER PACK!  
NEVER OPEN THIS FIXTURE WHILE IN USE!  
UNPLUG POWER BEFORE SERVICING FIXTURE!  
NEVER TOUCH FIXTURE DURING OPERATION, AS IT MAY BE HOT!  
KEEP FLAMMABLE MATERIALS AWAY FROM FIXTURE!**



**NEVER LOOK DIRECTLY INTO THE LIGHT SOURCE!  
RETINA INJURY RISK - MAY INDUCE BLINDNESS!  
SENSITIVE PERSONS MAY SUFFER AN EPILEPTIC SHOCK!**



**INDOOR / DRY LOCATIONS USE ONLY!  
DO NOT EXPOSE FIXTURE TO RAIN AND/OR MOISTURE!**



**MINIMUM DISTANCE TO OBJECTS/SURFACES  
IS 1.0 FOOT (0.3 METER)  
MINIMUM DISTANCE OF FLAMMABLE MATERIALS  
FROM THE SURFACE IS 1.6 FEET (0.5 METER)  
MAXIMUM AMBIENT OPERATING TEMPERATURE IS 113°F (45°C)**

# SAFETY GUIDELINES

**DO NOT TOUCH** the fixture housing during operation.

**DO NOT** shake fixture and avoid brute force when installing and/or operating fixture.

**DO NOT** operate fixture if the power cord is frayed, crimped, damaged and/or if any of the power cord connectors are damaged or do not fit into the fixture securely with ease.

**NEVER** force a power cord connector into the fixture. If the power cord or any of its connectors are damaged, replace it immediately with a new one of similar power rating.

**DO NOT** block any air ventilation slots. All fan and air inlets must remain clean and never blocked. Allow approx. 6" (15cm) between fixture and other devices or a wall for proper cooling.

**TURN OFF** the power and allow approximately 15 minutes for the fixture to cool down before serving.

**ALWAYS** disconnect fixture from power before performing any service and/or cleaning procedure.

**ONLY** handle power cord by the plug end, never pull plug out by tugging the wire portion of the cord.

During the initial operation of this fixture, a light smoke or smell may emit from the interior of the fixture. This is a normal process and is caused by excess paint in the interior of the casing burning off from the heat associated with the LED and will decrease gradually over time.

Consistent operational breaks will ensure fixture will function properly for many years.

**ONLY** use the original packaging and materials to transport the fixture for service.

# MAINTENANCE GUIDELINES



**DISCONNECT POWER BEFORE PERFORMING ANY MAINTENANCE!**

## CLEANING

Frequent cleaning is recommended to ensure proper function, optimized light output, and an extended life. The frequency of cleaning depends on the environment in which the fixture operates: damp, smoky or particularly dirty environments can cause greater accumulation of dirt on the fixture's optics. Clean periodically with a soft cloth to avoid dirt/debris accumulation.

**NEVER** use alcohol, solvents, or ammonia-based cleaners.

## MAINTENANCE

Regular inspections are recommended to insure proper function and extended life.

There are no user serviceable parts inside this fixture, please refer all other service issues to an authorized Elation service technician. Should you need any spare parts, please order genuine parts from an authorized Elation dealer.

Please refer to the following points during routine inspections:

- A detailed electric check by an approved electrical engineer every three months, to make sure the circuit contacts are in good condition and prevent overheating.
- Be sure all screws and fasteners are securely tightened at all times. Loose screws may fall out during normal operation resulting in damage or injury as larger parts could fall.
- Check for any deformations on the housing, color lenses, rigging hardware and rigging points (ceiling, suspension, trussing). Deformations in the housing could allow for dust to enter into the fixture. Damaged rigging points or unsecured rigging could cause the fixture to fall and seriously injure a person(s).
- Electric power supply cables must not show any damage, material fatigue or sediments.
- **NEVER** remove the ground prong from the power cable.

# OVERVIEW

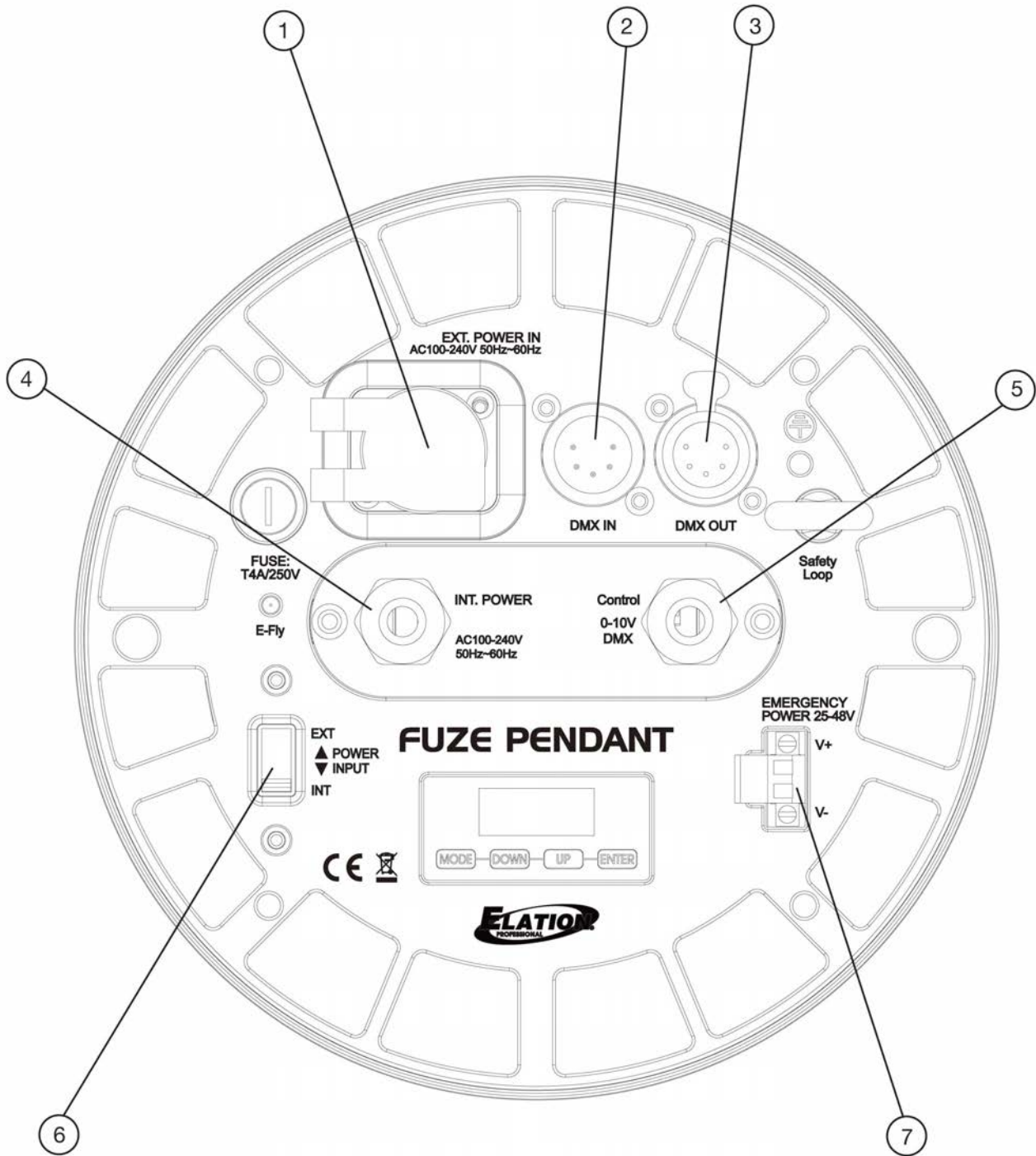

1. Locking Power Connector
2. DMX Input – 5-pin XLR Male
3. DMX Output – 5-pin XLR Female
4. Wired Power Input Cable Gland

5. Wired DMX Cable Gland
6. Power Input Switch
7. Emergency Power Input Terminal

# OVERVIEW

## POWER CONNECTIONS

Power may be provided to the fixture by means of an industry standard **locking power connector (1)**. Alternately, for more permanent installations, a power line may be wired to the fixture by connecting a line to the **wired power input cable gland (4)**. A wiring block is located directly behind this gland, with wire terminals for Live (L), Neutral (N), and Floating Ground (FG). This terminal block is accessed by removing the center plate in the connection panel.

Additionally, the fixture may be configured to draw power from either input by means of the **power input switch (6)**. The fixture will draw power from the **locking power connector (1)** when the switch is set to the “EXT” position, or the **wired power input cable gland (4)** when the switch is set to the “INT” position.

## DMX CONNECTIONS

DMX communication to and from the fixture may be provided by the **DMX 5-pin male XLR input (2)** and the **DMX 5-pin female XLR output (3)**. Alternately, for more permanent installation, a DMX line may be wired to the fixture by connecting the line to the **wired DMX cable gland (5)**. A wiring block is located directly behind this gland, with wire terminal for DMX +, DMX -, and DMX GND. This terminal block is accessed by removing the center plate in the connection panel. The terminal block also contains two additional terminals for 10V+ and 10V-, but these terminals are discussed in the following section.

## 0-10V / CONTACT CLOSURE CONNECTION

The terminal block that is used for the hard-wired DMX connections also includes terminals for 10V+ and 10V-. These two terminals may be used to connect the fixture to a current sink 0-10V dimmer to enable adjustment of lighting intensity, or they may be used to connect the fixture to a contact closure such as a wall switch or an emergency alarm panel.

## EMERGENCY POWER

The **emergency power input terminal (7)** can be connected to a 25-48V DC power source in order to provide emergency lighting in the event of loss of AC power. The DC power source should be rated for 15W or 20W in order to provide sufficient power for the fixture to operate for a minimum of 90 minutes. Please note that neither color nor light output will be adjustable when the fixture is operating in this mode, as the fixture has been optimized for maximum runtime at the required light levels.

**Please note that it is the responsibility of the user to determine the system design, wiring, and illumination levels required by law for emergency lighting systems in the locality in which the system will be operating. Emergency lighting must comply with all applicable national, state, and local standards.**

# OPTIONAL ACCESSORY INSTALLATION GUIDELINES

## LENS KIT

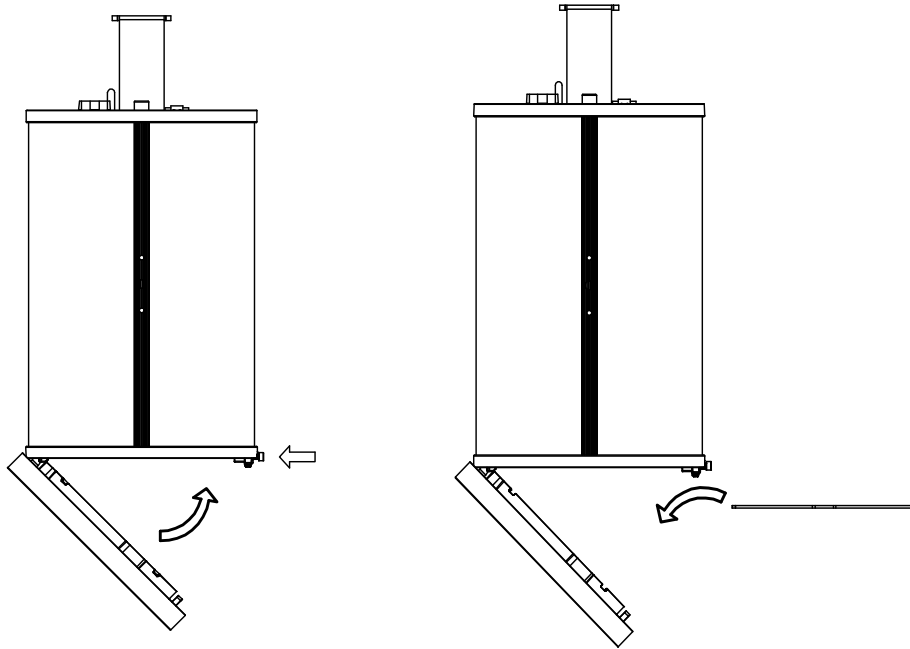

**PLACE FIXTURE ON A STABLE SURFACE AND LET COOL FOR 15 MINUTES!**

**DO NOT OVER TIGHTEN SCREWS! DO NOT USE A POWER SCREWDRIVER!**

1. Loosen screw on the side of lens bezel to open/release, as shown in the image on the left.
2. Carefully install lens in place, as shown in the image on the right.
3. Check lens is positioned correctly in the fixture then close/secure lens bezel.

# OPTIONAL ACCESSORY INSTALLATION GUIDELINES

## YOKE BRACKET KIT

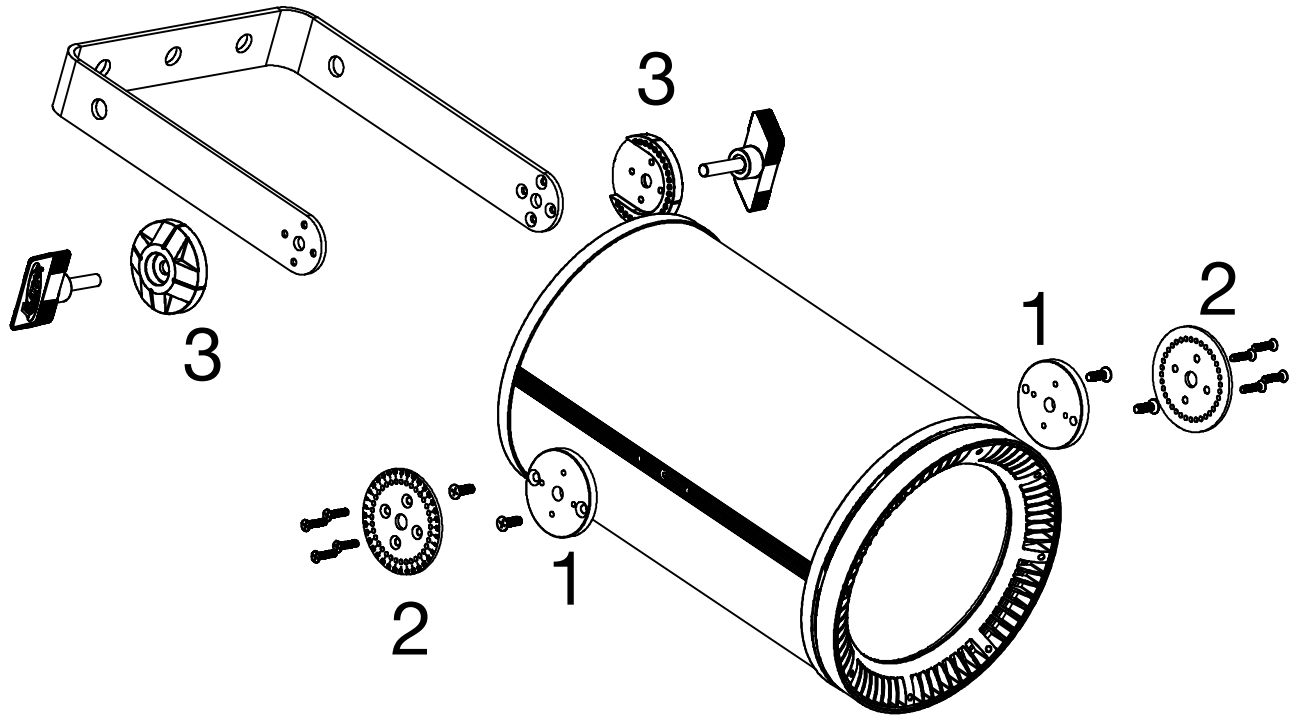

**PLACE FIXTURE ON A STABLE SURFACE AND LET COOL FOR 15 MINUTES!  
DO NOT OVER TIGHTEN SCREWS! DO NOT USE A POWER SCREWDRIVER!**

1. Attach yoke spacer disc (x2) to fixture with (x2) screws each.
2. Attach yoke inner mounting disc (x2) to the yoke spacer discs with (x4) screws each.
3. Align yoke, yoke outer mounting disc (x2), and hand knob (x2) over the yoke inner mounting discs, then insert and rotate hand knobs clockwise to secure yoke in desired position.

# OPTIONAL ACCESSORY INSTALLATION GUIDELINES

## HALF AND FULL SNOOT KIT

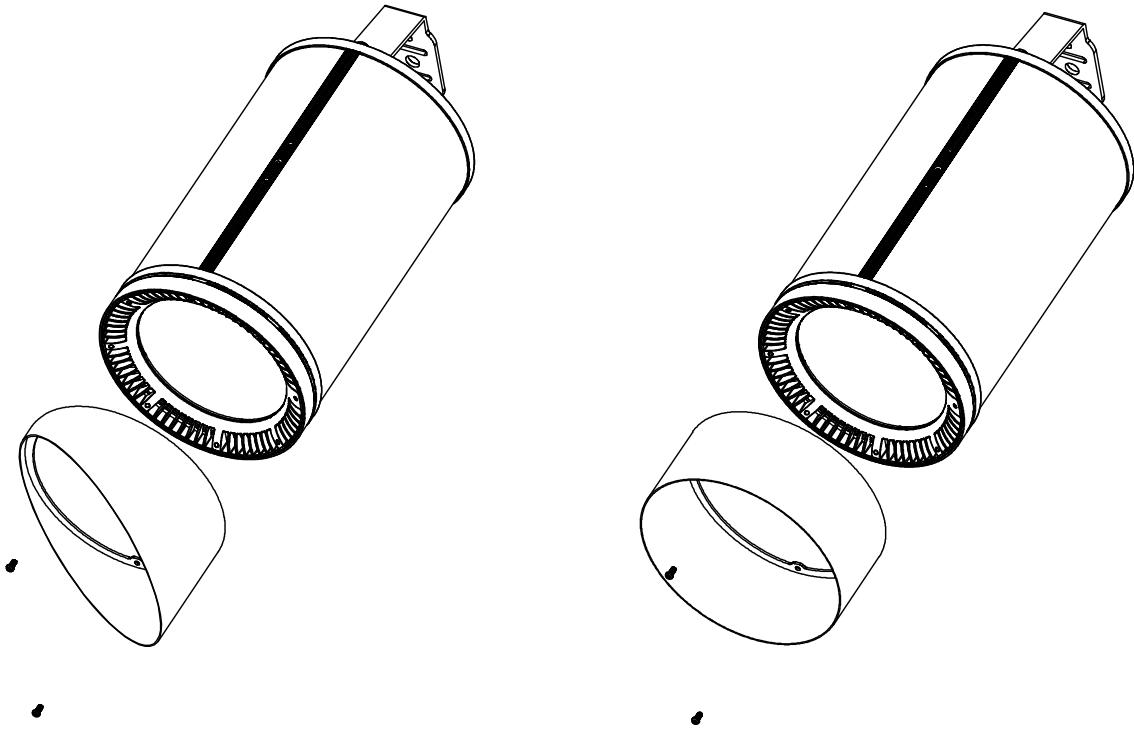

**PLACE FIXTURE ON A STABLE SURFACE AND LET COOL FOR 15 MINUTES!**

**DO NOT OVER TIGHTEN SCREWS! DO NOT USE A POWER SCREWDRIVER!**

1. Attach snoot to the fixture lens bezel and secure in place with (x2) screws.

# OPTIONAL ACCESSORY INSTALLATION GUIDELINES

## CEILING MOUNT KIT – SAFETY WARNINGS

The evaluation of a suitable installation surface such as wood, drywall or other materials is the responsibility of the installer, architect, engineer or other skilled person involved in the mounting and securing of the fixture.

The Fuze Pendant itself has a weight of **15.8lbs (7.2 kg)**, which the installation surface must be able to support securely. If in any doubt regarding the suitability of the surface, all weight must be carried by the hanging bracket, with the ceiling mount kit only utilized as a visual trim kit for a clean installation. The ceiling kit / trim ring can be installed with or without the provided body support plates.

The Fuze Pendant and ceiling kit are NOT plenum rated.

The Fuze Pendant must ALWAYS be secured by a secondary safety cable from its included safety eyelet to an independent structural element. Such elements can be ceiling joists, concrete ceilings and other structural systems which can secure the fixture in case of failure of the mounting surface to carry the Fuze Pendant securely.

**Failure to provide the secondary safety can lead to serious injury or death.**

The secure installation of the Fuze Pendant is always the responsibility of the customer, as the evaluation of surfaces and installation methods is beyond the scope of Elation Professional to predict. A structural engineer should be consulted for all overhead installations of fixtures to provide calculations and approval for weights, primary and safety attachment points and suitability of surfaces and appropriate fastening methods.

Secure and structurally safe installation approved by an engineer is imperative for mounting the Fuze Pendant into recessed ceilings.

**Elation Professional is not responsible for the installation methods and choices of installation surfaces.**

**Improper installation, unsuitable surfaces and failure to secure a secondary safety cable can lead to serious injury or death.**

# OPTIONAL ACCESSORY INSTALLATION GUIDELINES

## CEILING MOUNT KIT - INSTALLATION

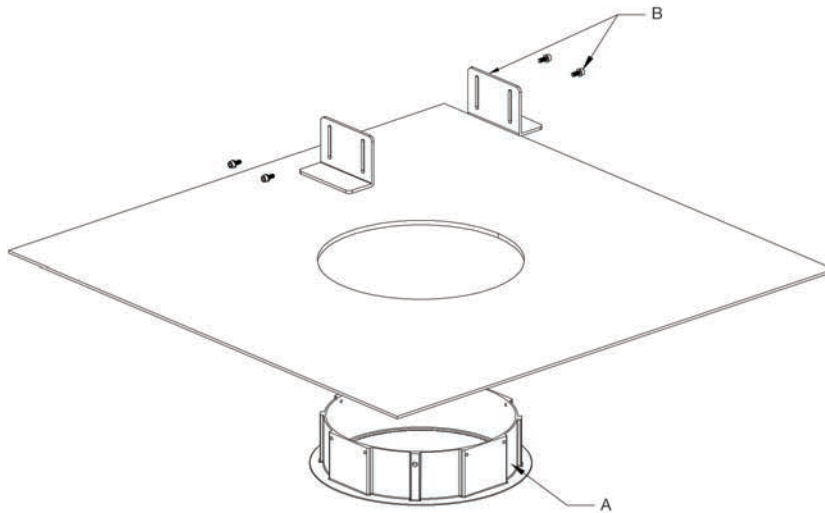

1. Open an 8.5-inch diameter hole in the desired ceiling panel. Insert the aluminum trim ring **(A)** through the hole from the underside of the panel, then secure the trim ring in place with the included screws, washers, and support brackets **(B)**.

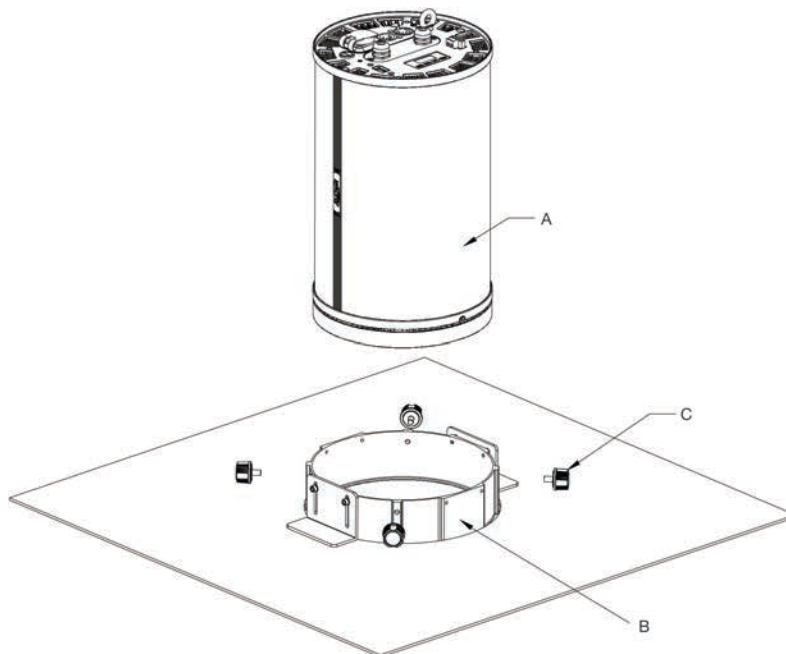

2. Lower the lighting fixture **(A)** into the trim ring **(B)** from above. Secure the lighting fixture in place by tightening the four (4) thumb screws **(C)**.

# OPTIONAL ACCESSORY INSTALLATION GUIDELINES

## CEILING MOUNT KIT - INSTALLATION

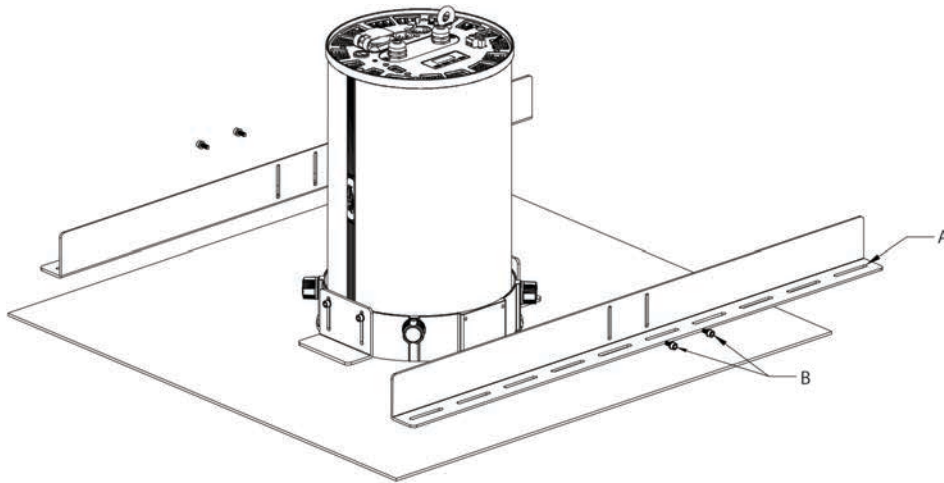

3. Attach the body support plates **(A)** to the trim ring using the included screws and washers **(B)**.

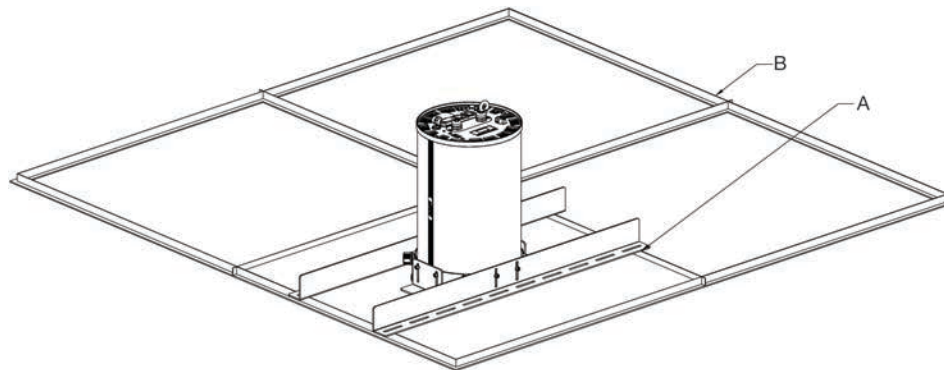

4. Install the entire assembly back into the ceiling at the desired location, making sure that the ends of the body support plates **(A)** are resting on firmly on the ceiling support grid **(B)**. Secure the body support plates in place using the appropriate hardware.

# OPTIONAL ACCESSORY INSTALLATION GUIDELINES

## CEILING MOUNT KIT - COMPONENT LIST

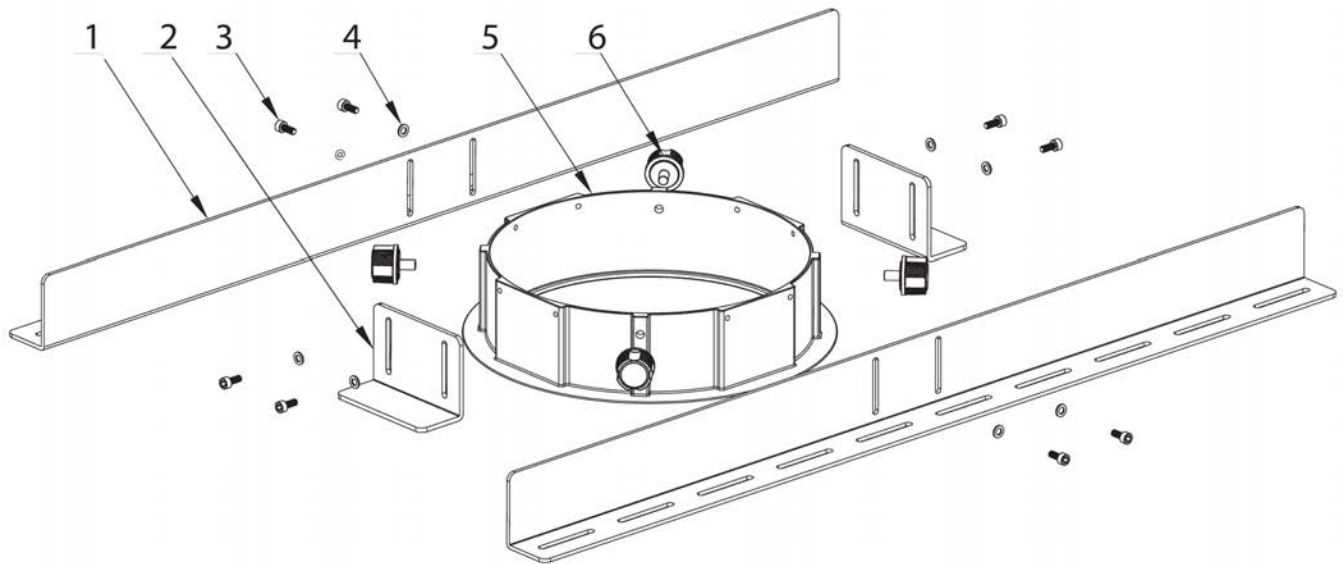

ITEM NO.	ITEM	QTY.
1	Body Support Plate	2
2	Trim Ring Support Bracket	2
3	Hex Screw, M4x10	8
4	Flat Head Washer, M4x8x0.8	8
5	Trim Ring	1
6	Thumb Screw, M6x10	4

# FIXTURE INSTALLATION GUIDELINES



## **FLAMMABLE MATERIAL WARNING**

Keep fixture minimum 5.0 feet (1.5m) away from flammable materials and/or pyrotechnics.



## **ELECTRICAL CONNECTIONS**

A qualified electrician should be used for all electrical connections and/or installations.



## **MINIMUM DISTANCE TO OBJECTS/SURFACES IS 1 FOOT (0.3 METERS)**



## **MINIMUM DISTANCE OF FLAMMABLE MATERIALS FROM THE SURFACE IS 1.6 FEET (0.5 METER)**



## **MAXIMUM AMBIENT TEMPERATURE 113° F (45°C)**



## **DO NOT INSTALL THE FIXTURE IF YOU ARE NOT QUALIFIED TO DO SO!**

Fixture **MUST** be installed following all local, national, and country commercial electrical and construction codes and regulations.

Before rigging/mounting a single fixture or multiple fixtures to any metal truss/structure or placing the fixture(s) on any surface, a professional equipment installer **MUST** be consulted to determine if the metal truss/structure or surface is properly certified to safely hold the combined weight of the fixture(s), clamps, cables, and accessories.

Overhead rigging requires extensive experience, including amongst others calculating working load limits, installation material being used, and periodic safety inspection of all installation material and the fixture. If you lack these qualifications, do not attempt the installation yourself. Improper installation can result in bodily injury.

Fixture(s) should be installed in areas outside walking paths, seating areas, or away from areas where unauthorized personnel might reach the fixture by hand.

**NEVER** stand directly below the fixture(s) when rigging, removing or servicing.

Overhead fixture installation must always be secured with a secondary safety attachment, such as an appropriately rated safety cable.

Allow approximately 15 minutes for the fixture to cool down before serving.

# FIXTURE INSTALLATION GUIDELINES

## RIGGING

Overhead rigging requires extensive experience, including calculating working load limits, knowledge of installation material being used, and periodic safety inspection of all installation material and the fixture, among other things. If you lack these qualifications, do not attempt the installation yourself. Improper installation can result in bodily injury.

## CLAMP INSTALLATION

When mounting fixture to truss, be sure to secure an appropriately rated professional grade rigging clamp to the included **Pendant Bracket** or the optional **Yoke Bracket** using an M10 screw fitted through the center hole. The fixture provides a built-in rigging point for a **SAFETY CABLE**. Be sure to only use one of the designated rigging points for the safety cable and never secure a safety cable to the Pendant or Yoke Brackets.



**ALWAYS ATTACH AN APPROPRIATELY RATED SAFETY CABLE (NOT INCLUDED) THAT MEETS ALL LOCAL, NATIONAL, AND COUNTRY CODES AND REGULATIONS WHENEVER INSTALLING FIXTURE IN A SUSPENDED ENVIRONMENT!**

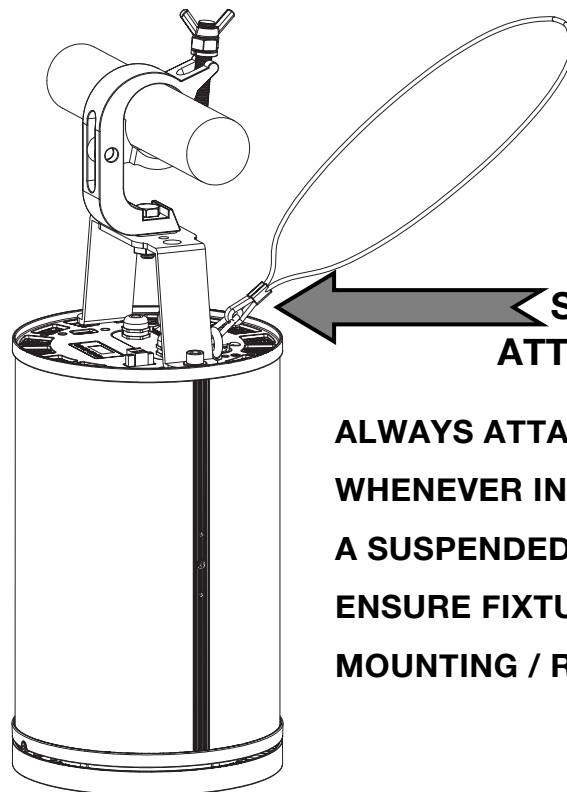

**SAFETY CABLE  
ATTACHMENT POINT**

**ALWAYS ATTACH A SAFETY CABLE  
WHENEVER INSTALLING THIS FIXTURE IN  
A SUSPENDED ENVIRONMENT TO  
ENSURE FIXTURE WILL NOT DROP IF  
MOUNTING / RIGGING HARDWARE FAILS.**

## E-FLY WIRELESS SET UP GUIDELINES

There are many factors that affect and/or interrupt a wireless signal such as walls, glass, metal, objects, and people. Therefore, it is highly recommended to:

- Install devices a minimum of 9.8 ft. (3m) above audiences and/or ground level
- Adjust the wireless antenna in a vertical upright position
- Position devices in direct line of sight of the controlling E-FLY device

Careful planning and testing of the selected installation location is critical to ensure optimum and reliable wireless operation.

9.8 ft (3m)  
Above Ground



# SYSTEM MENU

The fixture includes an easy to navigate system menu. The OLED control panel display located at the top of the fixture (see image below), provides access to the main system menu where all necessary system adjustments are made to the fixture. During normal operation, pressing the **MODE** button once will access the fixture's main menu. Once in the main menu you can navigate through the different functions and access the sub-menus with the **DOWN** and **UP** buttons. Once you reach a field that requires adjusting, press the **ENTER** button to activate that field and use the **DOWN** and **UP** buttons to adjust the field. Pressing the **ENTER** button once more will confirm the setting. Exit the main menu at any time without making any adjustments by pressing the **MODE** button.

To access the system menu, press and hold the **MODE** button for 3 seconds. The OLED display will shut **OFF** automatically approximately 1 minute from the last button press.

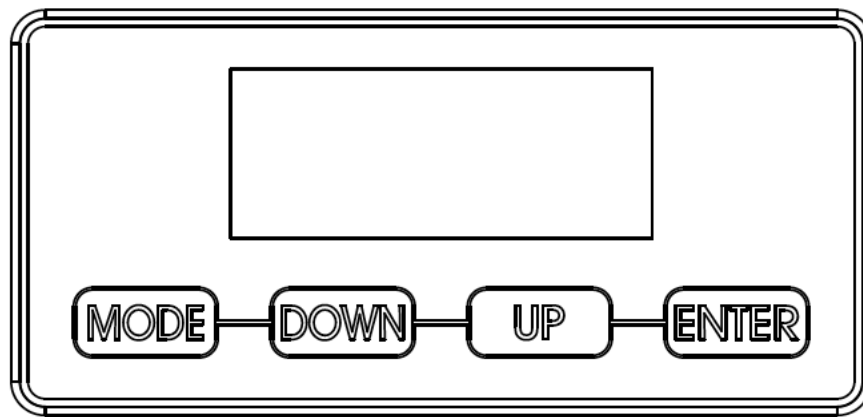

# SYSTEM MENU

ELATION FUZE PENDANT™ - SYSTEM MENU					
Supports Software Versions: ≥ 1.06					
<b>DMX Settings</b>	DMX Address	A001 ~ AXXX			
	DMX Channel Mode	Dimmer1CH, Dimmer Color 4CH, RGBWL 5CH, RGBWL 16bit 10CH, Standard 10CH, Extended 17CH, HSI 4CH, HSI Extended 9CH			
	No DMX Status	Hold Last, Fade to Black, Standalone, 0-10V			
	Priority	DMX, 0-10V			
<b>Standalone</b>	Dimmer	0-100%			
	ColorTemperature	2400-8500K			
	Virtual Color	Swatch Book, Color Scroll, Color C-Scroll, Random Slots			
	Fade Time	0-60s (10sec)			
	Use 0-10V	ON / OFF			
	Alarm Mode	ON / OFF			
<b>Personality</b>	Primary	ON / OFF			
	Secondary	ON / OFF			
	Dim Modes	Standard, Stage, TV, Architectural, Theatre, Stage 2, Dim Speed	0s, 0.1s, 0.2s, 0.3s, 0.4s, 0.5s, 0.6s, 0.7s, 0.8s, 0.9s, 1.0s, 1.5s, 2.0s, 3.0s, 4.0s, 5.0s, 6.0s, 7.0s, 8.0s, 9.0s, 10.0s		
	Dim Curves	Linear, Square, Square Inverse, S-Curve			
	E-FLY Settings	Set E-FLY Channel	00-14		
		Enable E-FLY	YES / NO		
	LED Refresh Rate	1200Hz, 900-1500Hz, 2500Hz, 4000Hz, 5000Hz, 6000Hz, 10KHz, 15KHz, 20KHz, 25KHz			
	LED Power Limit	50, 60, 70, 80, 90, 100%			
	Display	ScreenSaverDelay	1-10		
		Screen Lock	OFF, 30 Secs, 1-10mins		
		RotateDisplay180	YES / NO		
	Service	P a s s c o d e	Calibration	Red Green Blue White Lime	000-255 000-255 000-255 000-255 000-255
			Factory Restore	YES / NO	
		0 5 0	Edit RDM UID	xxxxxx	

<b>Manual Control</b>	Red	000-255			
	Green	000-255			
	Blue	000-255			
	White	000-255			
	Lime	000-255			
	Dimmer	000-255			
	Dimmer Fine	000-255			
	Strobe	000-255			
<b>Information</b>	FixtureLifeTime	Power On Time	xxxxxx Hours		
	FixLastRunTime	PowrOnTimAbleRes	xxxxxx Hours		
		PowerOnTimeReset	Passcode <b>038</b>		
	Total Lamp Hours	xxxxxx Hours			
	Fixture Temp	LED's	Current	xxxF / xxxC	
			Max Resettable	xxxF / xxxC	
			MaxNotResettable	xxxF / xxxC	
			LastMaxTempReset	Passcode <b>038</b>	
	DMX Values	Dimmer	000-255		
	Product ID's	RDM UID	xxxxxx		
	Error Logs	Fixture Errors	Error1, Error2, ...		
Reset Error Log		YES / <b>NO</b>	Passcode <b>050</b>		
Software Version	V1.06				

# SYSTEM MENU – DMX SETTINGS

## DMX ADDRESS

This function allows the user to define the DMX address of the fixture. This value is displayed as “AXXX” where XXX represents a 3-digit numerical values from 001 – 512.

## DMX CHANNEL MODE

This function allows the user to define the DMX channel mode in which the fixture will operate. See the **DMX Channel Functions** section for full details on which functions are included in each DMX channel mode.

## NO DMX STATUS

This function allows the user to define the behavior of the fixture in the event that DMX signal is lost. The user may select from one of the following options:

- ***Hold Last:*** The fixture adheres to the color and intensity settings that were in use immediately before DMX communication was lost, and continues to do so until DMX communication is re-established or a power cycle occurs. Please note that this mode is the fixture’s default setting.
- ***Fade to Black:*** The fixture fades to 0% intensity in the time span dictated by the **Standalone Fade Time** setting. Please refer to the **SYSTEM MENU – STANDALONE** section for details.
- ***Standalone:*** The fixture reverts to the **Color Temperature** and **Virtual Color** settings defined in the Standalone menu, in a time span dictated by the **Standalone Fade Time** setting. Please refer to the **SYSTEM MENU – STANDALONE** section for details.
- ***0-10V:*** The fixture reverts to the **Color Temperature** and **Virtual Color** settings defined in the Standalone menu, with the output intensity dictated by the 0-10V input.

## PRIORITY

This function allows the user to select whether the DMX signal or the 0-10V voltage level determines the intensity of the light output.

# SYSTEM MENU – STANDALONE

The Standalone System Menu allows the user to define how the fixture will behave when operating without DMX control. Color settings located in this menu also define the fixture output when operating in 1-Channel DMX Mode.

## DIMMER

This function is used to set the light output intensity of the fixture, from 0% to 100% of maximum output level.

## COLOR TEMPERATURE

This function is used to set the color temperature, and ranges from 2400 to 8500 K in intervals of 100 K.

## VIRTUAL COLOR

This function is used to select from a range of predefined color settings shown in the **Virtual Gel Swatch Book** table on page 36.

- **Swatch Book:** Select a single display color from the table.
- **Color Scroll:** Scrolls through all the colors in forward order of the Value listed in the **Virtual Gel Swatch Book** table shown on page 36. Scroll speed is adjustable from 0→22 (slowest to fastest).
- **Color C-Scroll:** Scrolls through all the colors in reverse order of the Value listed in the **Virtual Gel Swatch Book** table shown on page 36. Scroll speed is adjustable from 0→22 (slowest to fastest).
- **Random Slots:** Scrolls through all the colors shown on the **Virtual Gel Swatch Book** table shown on page 36 in random order. Scroll speed can be set to *Fast, Medium, or Slow*.

## FADE TIME

This function is used to define the time span in which the fixture transitions to the output color and intensity that have been selected in the **Color Temperature** and **Virtual Color** settings, ensuring a smooth transition between operation in DMX mode and Standalone mode. Available Fade Time options range from 0 seconds to 60 seconds, in 1-second intervals. The default setting for this fixture is 10 seconds.

## 0-10V CONTACT / ALARM CONTACT

These functions control the way that the fixture interprets the signal from the 0-10V connector. The **0-10V CONTACT** setting is used to enable or disable the fixture's ability to use the 0-10V input to determine the intensity of light output. Please note that if this feature is enabled, the fixture will adhere to the settings selected in the **Color Temperature** and **Virtual Color** functions of the Standalone System Menu.

Alternately, the **ALARM CONTACT** setting is used to enable or disable the fixture's ability to activate Standalone mode when input is received from the 0-10V connector. DMX control will simultaneously be disabled when the fixture enters this mode. Common uses for this feature include emergency lighting applications or a master power switch for repair and maintenance purposes.

# DIMMER MODES

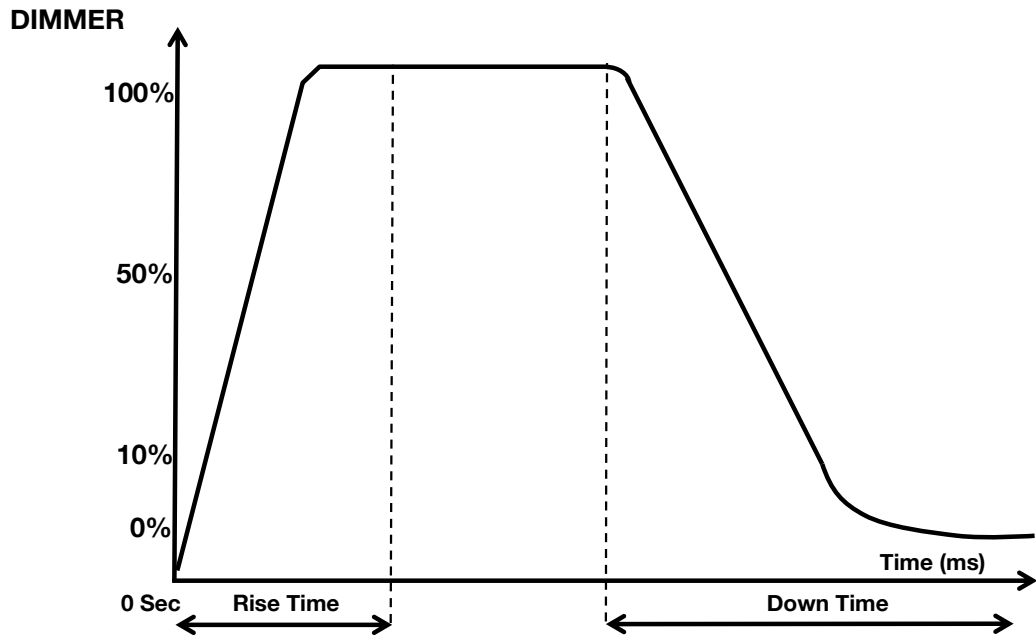

Dimming Curve Ramp Effect	0 sec Fade Time		1 sec Fade Time	
	Rise Time (ms)	Down Time (ms)	Rise Time (ms)	Down Time (ms)
Standard (default)	0	0	0	0
Stage	780	1100	1540	1660
TV	1180	1520	1860	1940
Architectural	1380	1730	2040	2120
Theatre	1580	1940	2230	2280
Stage 2	0	1100	0	1660

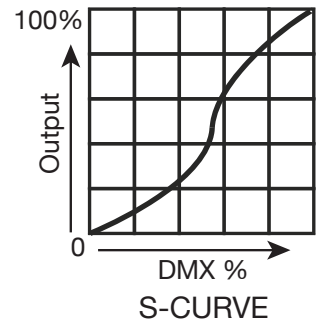
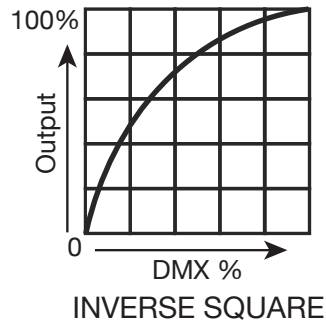
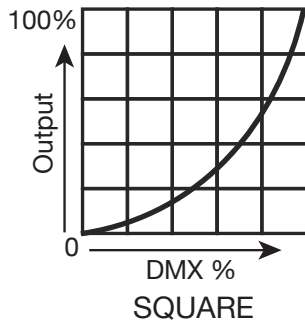
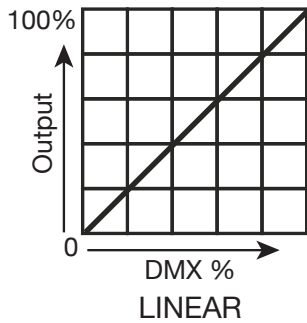

# DMX CHANNEL FUNCTIONS

## ELATION FUZE PENDANT™

### RGBWL MODES - DMX Channel Values / Functions (17 Total DMX Channels)

Supports Software Versions: ≥ 1.06

Features subject to change without notice.

1CH Dimmer	4CH Dimmer Color	5CH RGBWL	10CH RGBWL 16bit	10CH Standard	17CH Extended	Value	Function	Default	Snap
				1	1		<b>Strobe</b>		
						0 - 31	Closed	50	X
						32 - 63	Open		
						64 - 95	Strobe (slow → fast)		
						96 - 127	Open		
						129-159	Pulse (slow → fast)		
						160 - 191	Open		
						192 - 223	Random (slow → fast)		
						224 - 255	Open		
1	1			2	2		<b>Dimmer</b>		
						0 - 255	0 → 100%		
	2			3	3		<b>Dimmer Fine</b>	0	
						0 - 255	0 → 100%		

1CH Dimmer	4CH Dimmer Color	5CH RGBWL	10CH RGBWL 16bit	10CH Standard	17CH Extended	Value	Function	Default	Snap
		1	1	4	4		<b>Red</b>	255	
						0 - 255	0 → 100%		
			2		5		<b>Red Fine</b>	255	
						0 - 255	0 → 100%		
		2	3	5	6		<b>Green</b>	255	
						0 - 255	0 → 100%		
			4		7		<b>Green Fine</b>	255	
						0 - 255	0 → 100%		
		3	5	6	8		<b>Blue</b>	255	
						0 - 255	0 → 100%		
			6		9		<b>Blue Fine</b>	255	
						0 - 255	0 → 100%		
		4	7		10		<b>White</b>	255	
						0 - 255	0 → 100%		
			8		11		<b>White Fine</b>	255	
						0 - 255	0 → 100%		
		5	9		12		<b>Lime</b>	255	
						0 - 255	0 → 100%		
			10		13		<b>Lime Fine</b>	255	
						0 - 255	0 → 100%		
	3			7	14		<b>CTO</b>	0	
						0-23	Open		
						24 -85	CTO 2400K - 8500K (see Color Temperature Table)		
						86-255	8500K		
	4			8	15		<b>Color Wheel</b>	0	
						0	Open		
						1-179	Virtual Swatch Book (see Virtual Gel Swatch Book Table)		
							<b>Color Scroll</b>		
						180-201	Clockwise, fast → slow		
						202-207	Stop		
						208-229	Counter-clockwise, slow → fast		
						230-234	Open		
							<b>Random Slots</b>		
						235-239	Fast		
						240-244	Medium		
						245-249	Slow		
						250-255	Open		

1CH Dimmer	4CH Dimmer Color	5CH RGBWL	10CH RGBWL 16bit	10CH Standard	17CH Extended	Value	Function	Default	Snap
							<b>Dim Modes</b>		
						0 - 20	Standard		
						21 - 40	Stage		
						41 - 60	TV		
						61 - 80	Architectural		
						81 - 100	Theatre		
						101 - 120	Stage 2		
							<b>Dimmer Delay Time</b>		
						121	0s		
						122	0.1s		
						123	0.2s		
						124	0.3s		
						125	0.4s		
						126	0.5s		
				9	16	127	0.6s	0	X
						128	0.7s		
						129	0.8s		
						130	0.9s		
						131	1.0s		
						132	1.5s		
						133	2.0s		
						134	3.0s		
						135	4.0s		
						136	5.0s		
						137	6.0s		
						138	7.0s		
						139	8.0s		
						140	9.0s		
						141	10s		
						142 - 255	Idle		

1CH Dimmer	4CH Dimmer Color	5CH RGBWL	10CH RGBWL 16bit	10CH Standard	17CH Extended	Value	Function	Default	Snap
							<b>Control</b>		
						0-99	Idle		
							<b>Change Refresh Rate (Hz) (Hold 1s)</b>		
						100	900		
						101	910		
						102	920		
						103	930		
						104	940		
						105	950		
						106	960		
						107	970		
						108	980		
						109	990		
						110	1000		
						111	1010		
						112	1020		
						113	1030		
						114	1040		
						115	1050		
				10	17	116	1060	0	X
						117	1070		
						118	1080		
						119	1090		
						120	1100		
						121	1110		
						122	1120		
						123	1130		
						124	1140		
						125	1150		
						126	1160		
						127	1170		
						128	1180		
						129	1190		
						130	1200		
						131	1210		
						132	1220		
						133	1230		
						134	1240		
						135	1250		

1CH Dimmer	4CH Dimmer Color	5CH RGBWL	10CH RGBWL 16bit	10CH Standard	17CH Extended	Value	Function	Default	Snap
						136	1260		
						137	1270		
						138	1280		
						139	1290		
						140	1300		
						141	1310		
						142	1320		
						143	1330		
						144	1340		
						145	1350		
						146	1360		
						147	1370		
						148	1380		
						149	1390		
						150	1400		
						151	1410		
						152	1420		
						153	1430		
						154	1440		
						155	1450		
						156	1460		
						157	1470		
				10	17	158	1480	0	X
						159	1490		
						160	1500		
						161	2500		
						162	4000		
						163	5000		
						164	6000		
						165	10000		
						166	15000		
						167	20000		
						168	25000		
						169-200	Idle		
						201-210	Dimmer Curve Linear (default)		
						211-220	Dimmer Curve Square		
						221-230	Dimmer Curve Inverse Square		
						231-240	Dimmer Curve S-Curve		
						241	Internal program 1 (Scene 1-8)		
						242	Internal program 2 (Scene 9-16)		
						243	Internal program 3 (Scene 17-24)		
						244	Internal program 4 (Scene 25-32)		
						245	Internal program 5 (Scene 33-40)		
						246	Internal program 6 (Scene 41-48)		
						247	Internal program 7 (Scene 49-56)		
						248-255	Idle		

**ELATION FUZE PENDANT™**

**HSI MODES - DMX Channel Values / Functions (9 Total DMX Channels)**

**Supports Software Versions: ≥ 1.06**

Features subject to change without notice.

HSI 4CH	HSI Extended 9CH	Value	Function	Default	Snap
	1		<b>Strobe</b>	50	X
		0 - 31	Closed		
		32 - 63	Open		
		64 - 95	Strobe (slow → fast)		
		96 - 127	Open		
		129-159	Pulse (slow → fast)		
		160 - 191	Open		
		192 - 223	Random (slow → fast)		
	224 - 255	Open			
1	2		<b>Intensity</b>	0	
		0 - 255	0 → 100%		
2	3		<b>Intensity Fine</b>	0	
		0 - 255	0 → 100%		
3	4		<b>Hue</b>	255	
		0 - 255	0 → 100%		
4	5		<b>Saturation</b>	255	
		0 - 255	0 → 100%		
	6		<b>CTO</b>	0	
		0-23	Open		
		24 -85	CTO 2400K - 8500K (see Color Temperature Table)		
		86-255	8500K		
	7		<b>Color Wheel</b>	0	
		0	Open		
		1-179	Virtual Swatch Book (see Virtual Gel Swatch Table)		
			<b>Color Scroll</b>		
		180-201	Clockwise, fast → slow		
		202-207	Stop		
		208-229	Counter-clockwise, slow → fast		
		230-234	Open		
			<b>Random Slots</b>		
		235-239	Fast		
		240-244	Medium		
		245-249	Slow		
	250-255	Open			

HSI 4CH	HSI Extended 9CH	Value	Function	Default	Snap
			<b>Dim Modes</b>		
		0 - 20	Standard		
		21 - 40	Stage		
		41 - 60	TV		
		61 - 80	Architectural		
		81 - 100	Theatre		
		101 - 120	Stage 2		
			<b>Dimmer Delay Time</b>		
		121	0s		
		122	0.1s		
		123	0.2s		
		124	0.3s		
		125	0.4s		
		126	0.5s		
		127	0.6s		
		128	0.7s		
		129	0.8s		
		130	0.9s		
		131	1.0s		
		132	1.5s		
		133	2.0s		
		134	3.0s		
		135	4.0s		
		136	5.0s		
		137	6.0s		
		138	7.0s		
		139	8.0s		
		140	9.0s		
		141	10s		
		142 - 255	Idle		
	8			0	X

HSI	HSI Extended	Value	Function	Default	Snap
			<b>Control</b>		
		0-99	Idle		
			<b>Change Refresh Rate (Hz) (Hold 1s)</b>		
		100	900		
		101	910		
		102	920		
		103	930		
		104	940		
		105	950		
		106	960		
		107	970		
		108	980		
		109	990		
		110	1000		
		111	1010		
		112	1020		
		113	1030		
		114	1040		
	9	115	1050	0	X
		116	1060		
		117	1070		
		118	1080		
		119	1090		
		120	1100		
		121	1110		
		122	1120		
		123	1130		
		124	1140		
		125	1150		
		126	1160		
		127	1170		
		128	1180		
		129	1190		
		130	1200		
		131	1210		
		132	1220		
		133	1230		
		134	1240		
		135	1250		

HSI	HSI Extended	Value	Function	Default	Snap
		136	1260		
		137	1270		
		138	1280		
		139	1290		
		140	1300		
		141	1310		
		142	1320		
		143	1330		
		144	1340		
		145	1350		
		146	1360		
		147	1370		
		148	1380		
		149	1390		
		150	1400		
		151	1410		
		152	1420		
		153	1430		
		154	1440		
		155	1450		
		156	1460		
		157	1470		
	9	158	1480	0	X
		159	1490		
		160	1500		
		161	2500		
		162	4000		
		163	5000		
		164	6000		
		165	10000		
		166	15000		
		167	20000		
		168	25000		
		169-200	Idle		
		201-210	Dimmer Curve Linear (default)		
		211-220	Dimmer Curve Square		
		221-230	Dimmer Curve Inverse Square		
		231-240	Dimmer Curve S-Curve		
		241	Internal program 1 (Scene 1-8)		
		242	Internal program 2 (Scene 9-16)		
		243	Internal program 3 (Scene 17-24)		
		244	Internal program 4 (Scene 25-32)		
		245	Internal program 5 (Scene 33-40)		
		246	Internal program 6 (Scene 41-48)		
		247	Internal program 7 (Scene 49-56)		
		248-255	Idle		

<b>COLOR TEMPERATURE</b>			
<b>VALUE</b>	<b>COLOR TEMP (K)</b>	<b>VALUE</b>	<b>COLOR TEMP (K)</b>
24	2400	55	5500
25	2500	56	5600
26	2600	57	5700
27	2700	58	5800
28	2800	59	5900
29	2900	60	6000
30	3000	61	6100
31	3100	62	6200
32	3200	63	6300
33	3300	64	6400
34	3400	65	6500
35	3500	66	6600
36	3600	67	6700
37	3700	68	6800
38	3800	69	6900
39	3900	70	7000
40	4000	71	7100
41	4100	72	7200
42	4200	73	7300
43	4300	74	7400
44	4400	75	7500
45	4500	76	7600
46	4600	77	7700
47	4700	78	7800
48	4800	79	7900
49	4900	80	8000
50	5000	81	8100
51	5100	82	8200
52	5200	83	8300
53	5300	84	8400
54	5400	85	8500

VIRTUAL GEL SWATCH BOOK					
VALUE	FILTER#	COLOR	VALUE	FILTER#	COLOR
1	7	Pale Yellow	31	126	Mauve
2	103	Straw	32	49	Medium Purple
3	151	Gold Tint	33	58	Lavender
4	100	Spring Yellow	34	199	Palace Blue
5	10	Medium Yellow	35	119	Dark Blue
6	101	Yellow	36	132	Medium Blue
7	104	Deep Amber	37	120	Deep Blue
8	15	Deep Straw	38	165	Daylight Blue
9	179	Loving Amber	39	161	Slate Blue
10	21	Gold Amber	40	118	Light Blue
11	105	Orange	41	68	Sky Blue
12	158	Deep Orange	42	143	Pale Navy Blue
13	22	Dark Amber	43	131	Marine Blue
14	778	Millennium Gold	44	115	Peacock Blue
15	135	Deep Golden Amber	45	172	Lagoon Blue
16	24	Scarlet	46	116	Medium Blue Green
17	106	Primary Red	47	90	Dark Yellow Green
18	26	Bright Red	48	139	Primary Green
19	27	Medium Red	49	122	Fern Green
20	19	Fire	50	89	Moss Green
21	157	Pink	51	124	Dark Green
22	36	Medium Pink	52	88	Lime Green
23	111	Dark Pink	53	138	Pale Green
24	128	Bright Pink	54	203	Quarter CT Blue
25	148	Bright Rose	55	202	Half CT Blue
26	332	Special Rose Pink	56	201	FULL CT Blue
27	793	Vanity Fair	57	200	Double CT Blue
28	113	Magenta	58	206	Quarter CT Orange
29	46	Dark Magenta	59	205	Half CT Orange
30	48	Rose Purple	60	204	FULL CT Orange

# ERROR CODES

Error Codes subject to change without notice.	
ERROR CODES	DESCRIPTION
Temp Error	These messages will appear if there is a temperature and/or voltage malfunction.
0-10V Error	

# SPECIFICATIONS

## SOURCE

230W 5-in-1 RGBWL (Red, Blue, Green, White, Lime) LED Engine

50,000 Hour Average LED Life\*

\*Test lab conditions. May vary depending on several factors including but not limited to: Environmental Conditions, Power/Voltage, Usage Patterns (On-Off Cycling), Control, and Dimming.

## EFFECTS

Color Temperature Control 2,400K – 8,500K

Virtual Color Swatch Book

Dimmer, Dimmer Color, RGBWL, RGBWL 16-bit, Standard, Extended, HSI, & HSI Extended Control Options

Variable 16-bit Dimming Curve Modes

High Speed Electronic Shutter and Strobe

DMX and Menu adjustable LED Refresh Rate Frequency

## CONTROL / CONNECTIONS

8 DMX Channel Modes

Standalone and Primary, Secondary Modes

RDM (Remote Device Management)

0-10V Dimming (Current-Sink)

E-FLY™ Internal Extended Range Wireless DMX Transceiver

4 Button Control Panel and OLED Menu Display

Locking 5pin XLR Connector In/Out

Locking IP65 Power Connector In

3pin Bare Wire Terminal Block for Power

5pin Bare Wire Terminal Block for 0-10V, DMX

2pin Bare Wire Terminal Block for 48V Emergency Battery Input

## SIZE / WEIGHT

Length: 12.5" (318mm)

Diameter: 7.8" (197mm)

Weight: 15.8lbs. (7.2 kg)

## ELECTRICAL / THERMAL

AC 100-240V - 50/60Hz

230W Max Power Consumption

14°F to 113°F (-10°C to 45°C)

## APPROVALS / RATINGS

CE | cETLus | IP20

Specifications and improvements in the design of this unit and this manual are subject to change without notice.

**DIMENSIONAL DRAWINGS – Pendant Bracket Attached** (Not to Scale)

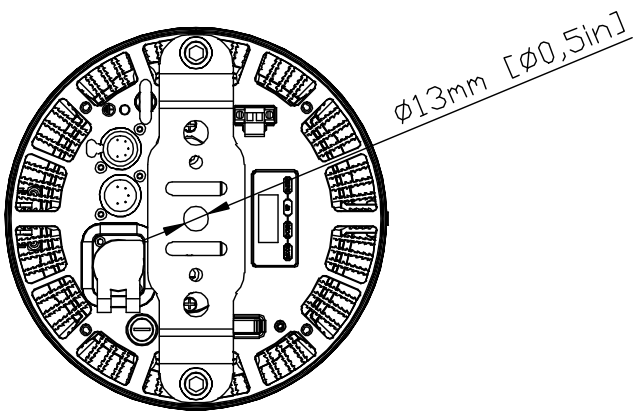
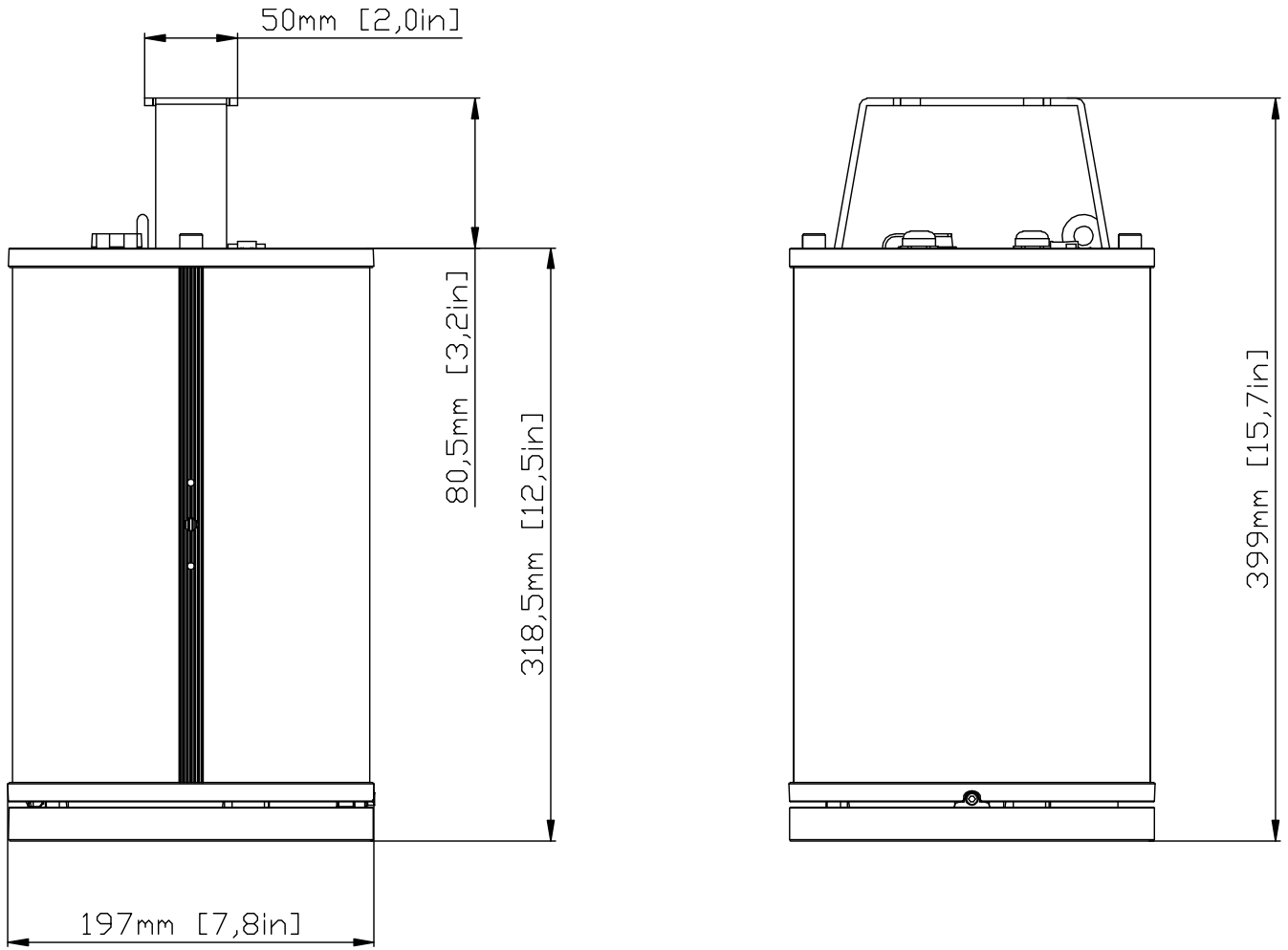

Specifications and improvements in the design of this unit and this manual are subject to change without notice.

**DIMENSIONAL DRAWINGS – Yoke Bracket Attached** (Not to Scale)

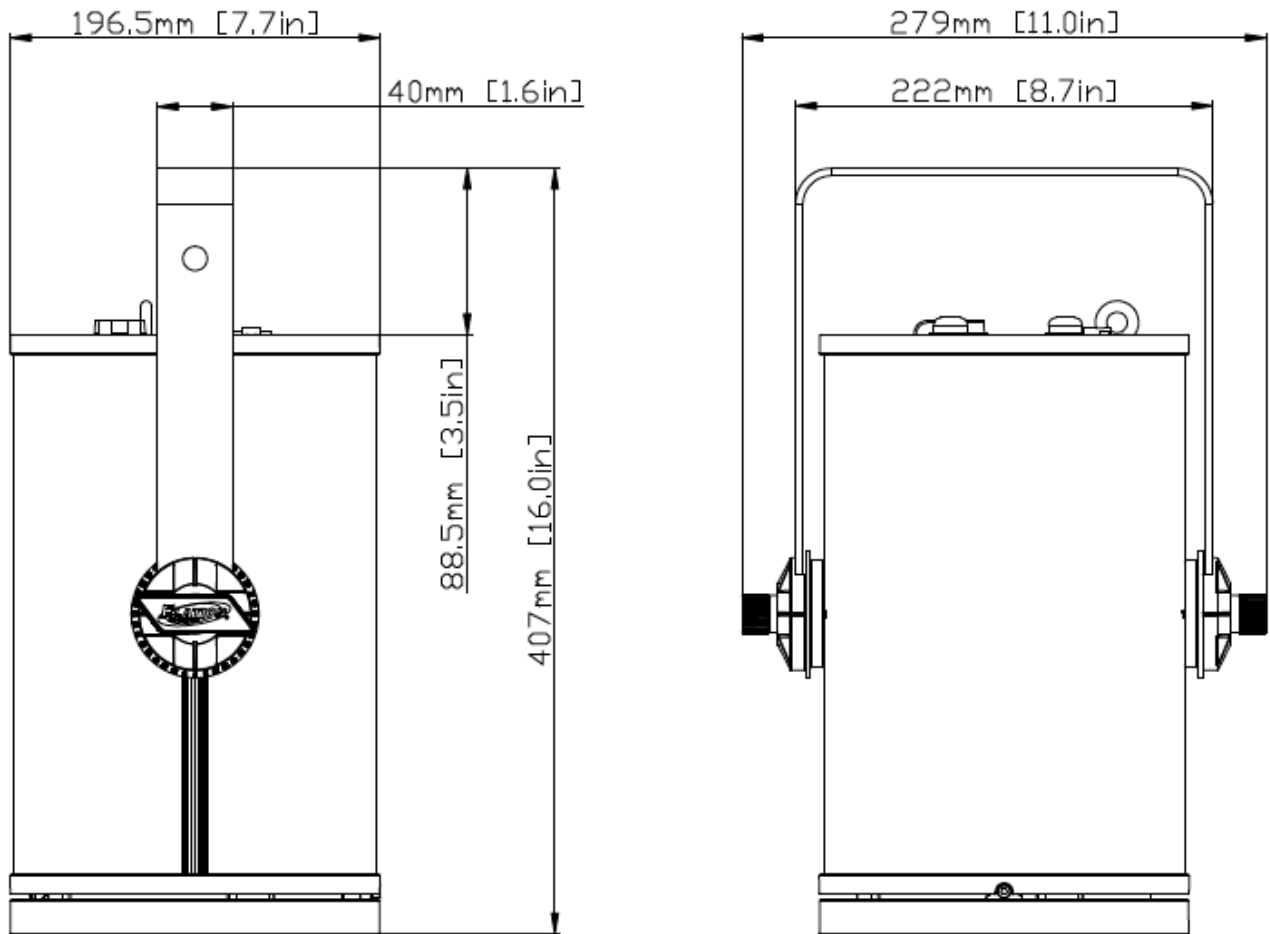

Specifications and improvements in the design of this unit and this manual are subject to change without notice.

**DIMENSIONAL DRAWINGS – Recessed Ceiling Kit Attached** (Not to Scale)

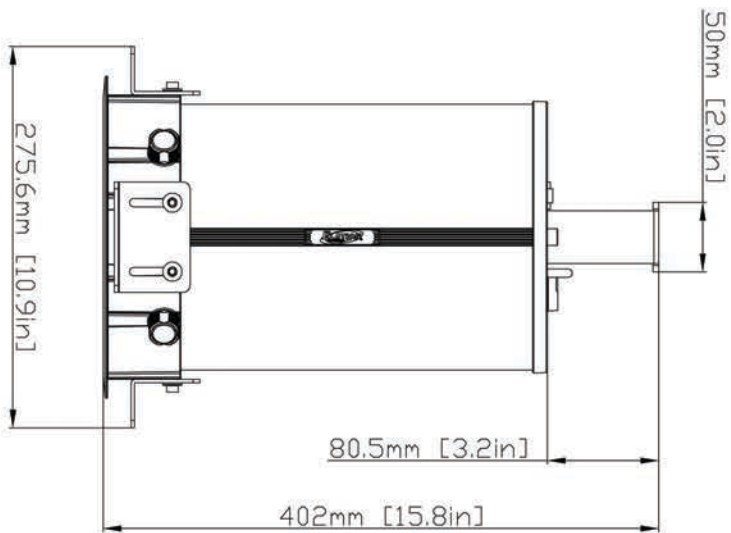
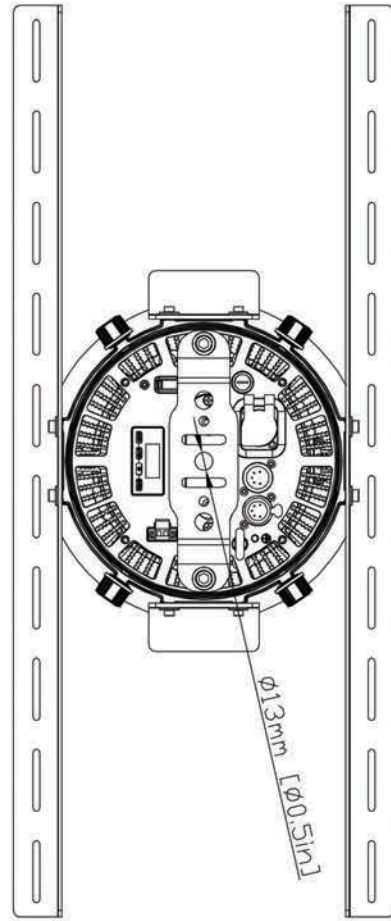
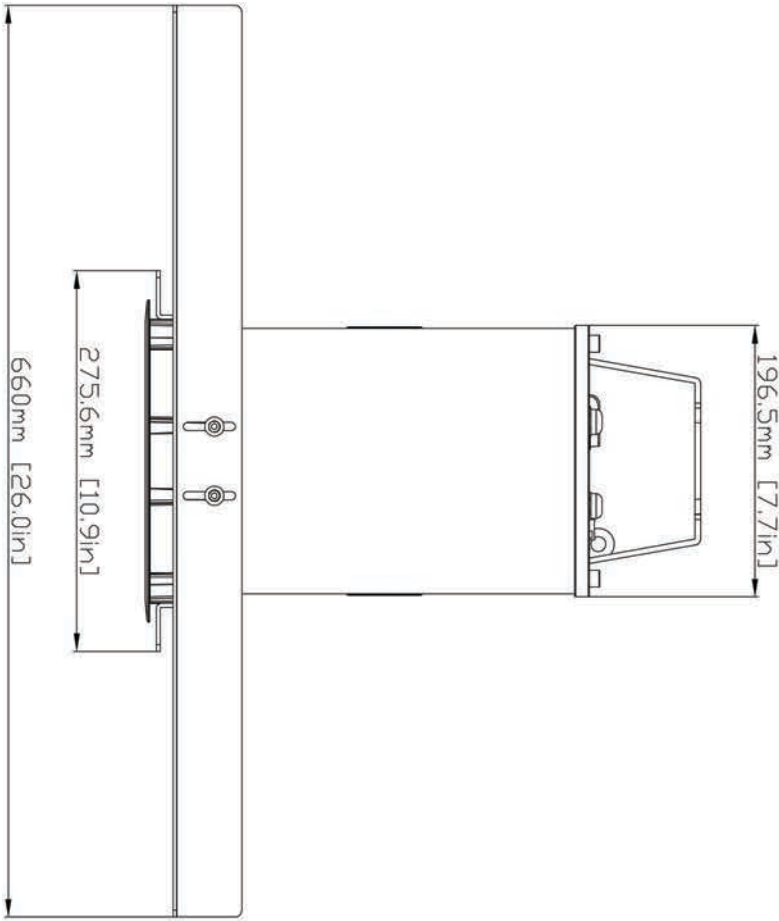

Specifications and improvements in the design of this unit and this manual are subject to change without notice.

**DIMENSIONAL DRAWINGS – Half Snoot Attached** (Not to Scale)

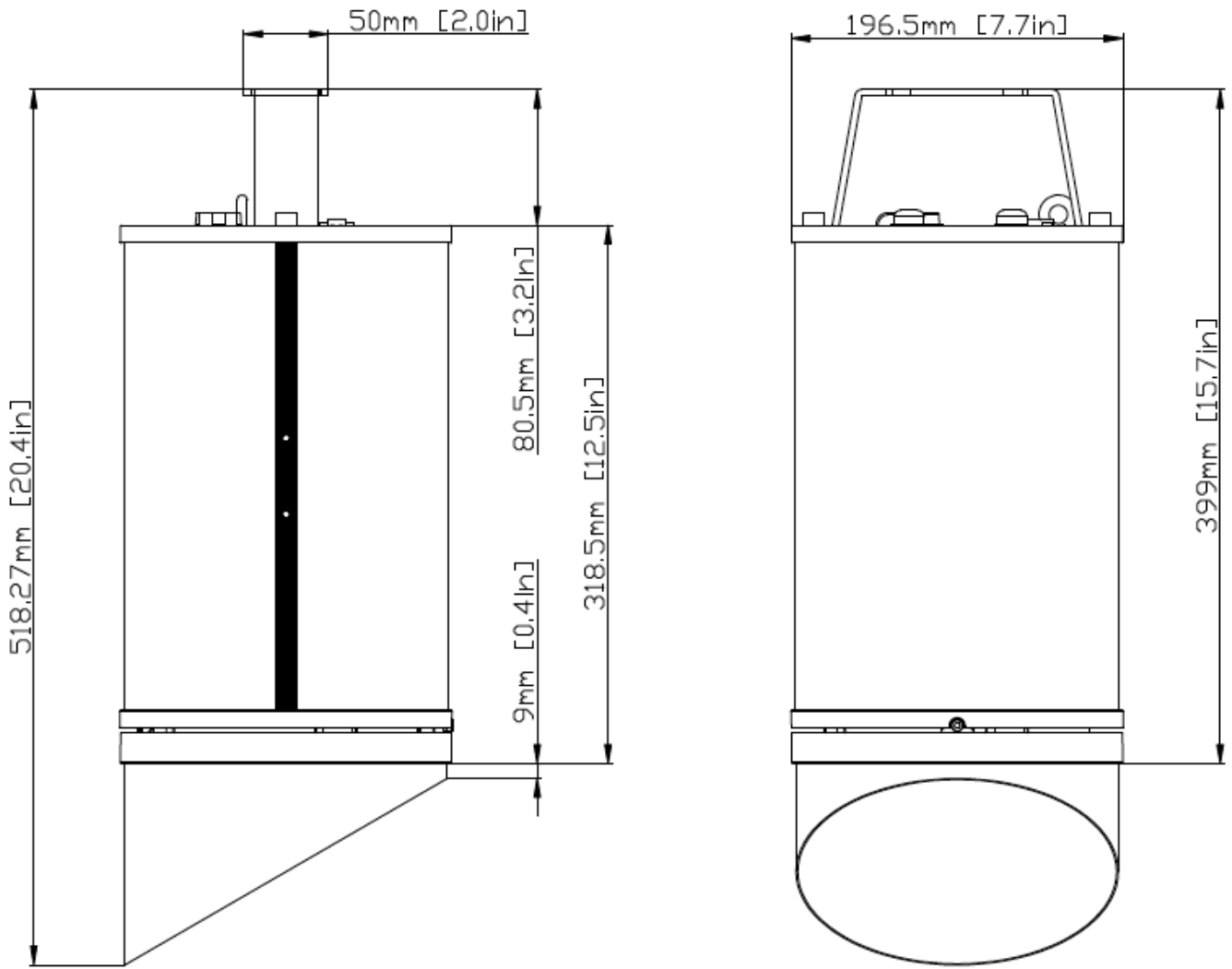

Specifications and improvements in the design of this unit and this manual are subject to change without notice.

**DIMENSIONAL DRAWINGS – Full Snoot Attached** (Not to Scale)

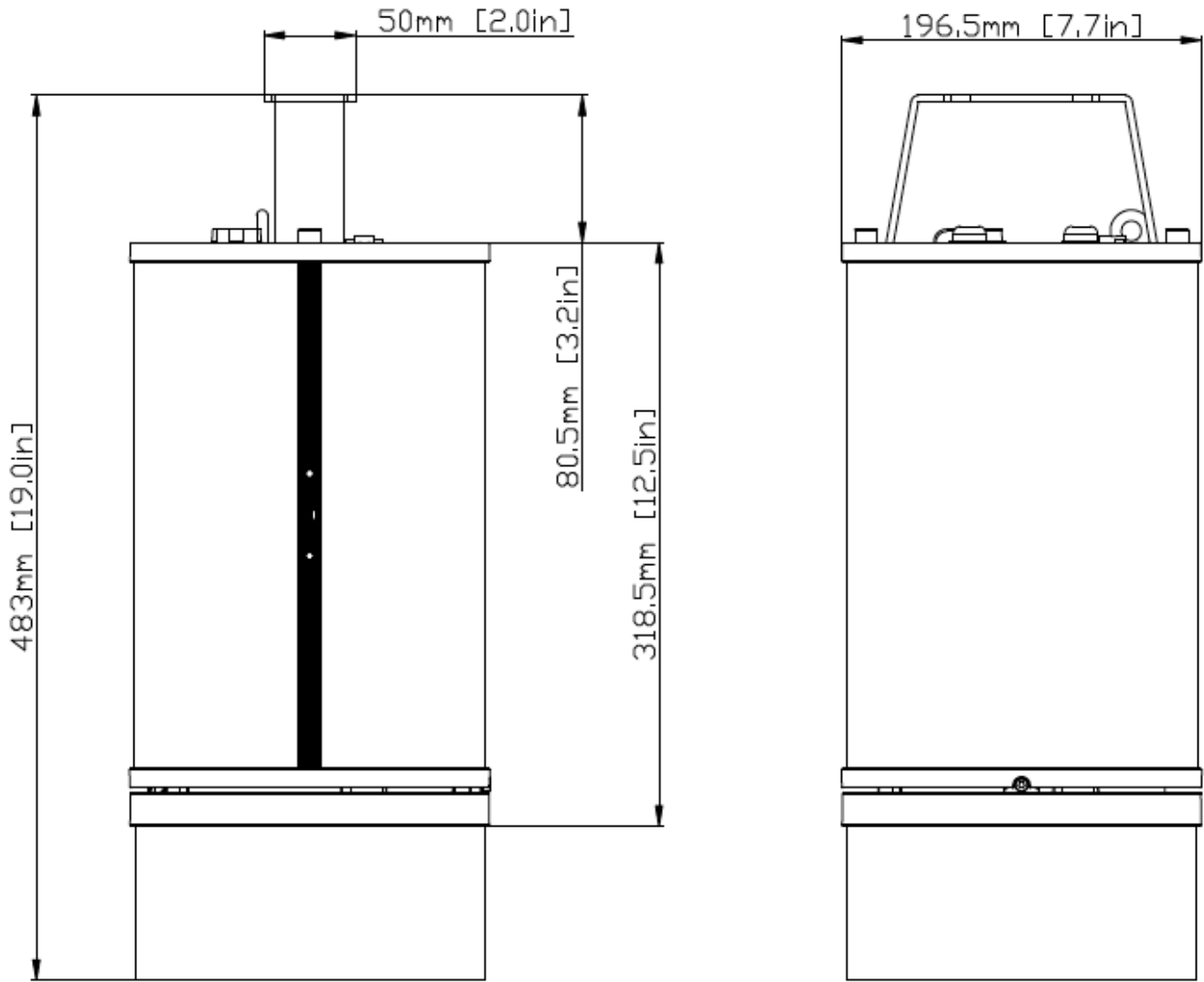

Specifications and improvements in the design of this unit and this manual are subject to change without notice.

## OPTIONAL ACCESSORIES

SKU (USA)	SKU (EU)	ITEM
FPL100	N/A	Fuze Pendant Lens 100°
FPL50	1237000228	Fuze Pendant Lens 50°
FPL40	1237000243	Fuze Pendant Lens 40°
FPL25	1237000229	Fuze Pendant Lens 25°
FPCMK	1237000244	Fuze Pendant Ceiling Mount Kit
FPYMK	1237000245	Fuze Pendant Yoke Mount Kit
FPHS	1237000246	Fuze Pendant Half Snoot
FPFS	1237000247	Fuze Pendant Full Snoot

## FCC STATEMENT

This device complies with Part 15 of the FCC Rules. Operation is subject to the following two conditions: (1) this device may not cause harmful interference, and (2) this device must accept any interference received, including interference that may cause undesired operation.

### FCC RADIO FREQUENCY INTERFERENCE WARNINGS & INSTRUCTIONS

This product has been tested and found to comply with the limits as per Part 15 of the FCC Rules. These limits are designed to provide reasonable protection against harmful interference in a residential installation. This device uses and can radiate radio frequency energy and, if not installed and used in accordance with the included instructions, may cause harmful interference to radio communications. However, there is no guarantee that interference will not occur in a particular installation. If this device does cause harmful interference to radio or television reception, which can be determined by turning the device off and on, the user is encouraged to try to correct the interference by one or more of the following methods:

- Reorient or relocate the device.
- Increase the separation between the device and the receiver.
- Connect the device to an electrical outlet on a circuit different from which the radio receiver is connected.
- Consult the dealer or an experienced radio/TV technician for help.

### Europe Energy Saving Notice

Energy Saving Matters (EuP 2009/125/EC)

Saving electric energy is a key to help protecting the environment. Please turn off all electrical products when they are not in use. To avoid power consumption in idle mode, disconnect all electrical equipment from power when not in use. Thank you

**USA# FUZ260**  
**EU# 1237000225**  
**UPC# 810008260869**  
**ITF-14# 10810008260866**