

Solo10G™ SFP+ Thunderbolt™ 3 Edition

10 Gigabit Ethernet to Thunderbolt 3 Adapter
with 10GBASE-SR (Short-range) SFP+ Transceiver

Quick Start Guide

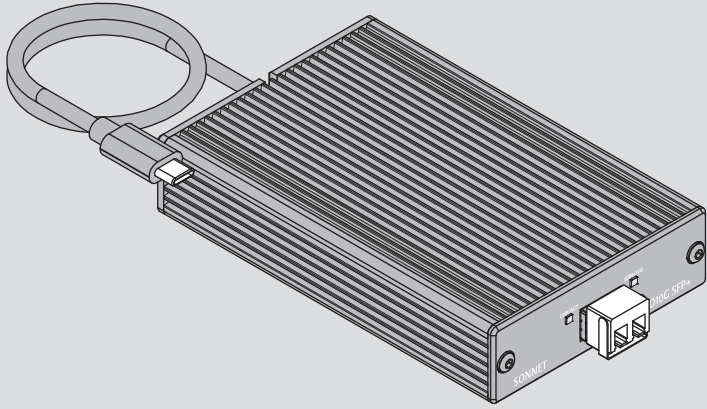

©2021 Sonnet Technologies, Inc. All rights reserved. Sonnet, SONNETTECH, the Sonnettech logotype, and Solo10G are trademarks of Sonnet Technologies, Inc. Mac, the Mac logo, and macOS are trademarks of Apple Inc., registered in the United States and other countries. Thunderbolt and the Thunderbolt logo are trademarks of Intel Corporation in the U.S. and/or other countries. Other product names are trademarks of their respective owners. Product specifications subject to change without notice. QS-SOLO10G-SFP-TB3-E-D-061821

Mac® Compatibility

- Mac (Intel® or M1) with Thunderbolt 3 ports
- macOS® 10.13.6+
- macOS Big Sur compatible

Windows® Compatibility

- PC with Thunderbolt 3 or Thunderbolt 4 ports
- Windows 10 (64-bit Edition Version 2004 or greater)

Important Note: Windows computers require the latest BIOS and Thunderbolt drivers to support this product. Check with your computer manufacturer for update information.

Linux® Compatibility

- PC with Thunderbolt 3 ports
- Linux Kernel 5.0 or later



Support Note: This document was up to date at the time of printing. However, changes to the hardware or software may have occurred since then. Please check the Sonnet website for the latest documentation.

1. Go to <https://www.sonnettech.com/support/kb/kb.php>
2. Navigate to and click the Solo10G SFP+ Thunderbolt 3 Edition link.
3. Click the Manual link.
4. Click the Solo10G SFP+ Thunderbolt 3 Edition Quick Start Guide [English] link and then check the Document Version information. If the version listed is later than this document (**revision D**), click the Download Now button for the latest version.

1

Solo10G SFP+ Thunderbolt 3 Edition (T3E) Description

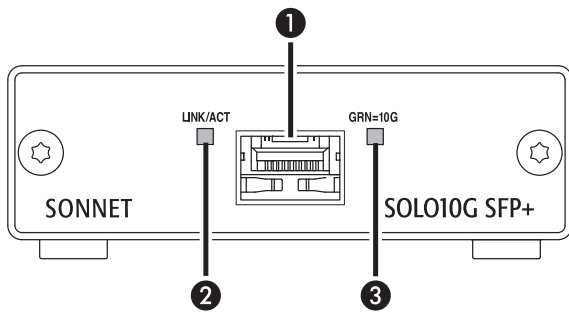

1 – SFP+ Socket

Insert the included short-range SFP+ optical transceiver into the socket, making sure it is firmly seated and secured. Alternatively, you can install a long-range SFP+ transceiver or an RJ45 SFP+ copper transceiver (both sold separately). You may even use a direct-attached SFP+ terminated copper cable up to 10 meters long (sold separately) to connect to a switch or storage system.

2 – Link/Activity Indicator

This LED lights up green to indicate a link is established between the adapter and the switch, and flashes yellow when the link is training.

3 – Link Speed Indicator

When a link is established between the adapter and the switch, this LED lights to indicate the link speed to the switch: green = 10Gb, yellow = lower speeds.

2

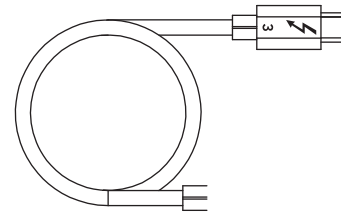

Thunderbolt 3 Connector—Plug this connector into one of your computer's Thunderbolt 3 ports (often indicated by a lightning bolt logo), or at the end of a Thunderbolt device chain. Ports marked with the USB icon (⚡) are NOT compatible.

Driver Information

For Mac users, the drivers required to support this product are installed as part of macOS 10.13.6 and later; the Sonnet adapter is ready for use when you power on your computer.

For Windows users, please go to www.sonnettech.com/support/kb/kb.php. Navigate to and click the Solo10G SFP+ Thunderbolt 3 Edition link, and then click the Driver link. Locate, download, and install the Windows drivers.

For Linux users, the drivers required to support this product are installed as part of Linux Kernel 5.0 and later, though more current drivers may be available: Go to www.sonnettech.com/support/kb/kb.php, navigate to and click the Solo10G SFP+ Thunderbolt 3 Edition link, and then click the Driver link. If the listed Linux driver version is later than the one installed in your system, download and install the drivers.

3

Basic Configuration Information—macOS

With the Solo10G adapter connected to your computer and network infrastructure, configure the adapter's settings in the System Preferences' Network preferences panel. The adapter will be identified as Thunderbolt Ethernet Slot *x*.

Performance Tuning Steps—macOS

Listed below are steps required to configure the Solo10G SFP+ T3E adapter for maximum performance.



Support Note: In order to realize maximum performance, the adapter's duplex setting must be set to full-duplex, and the MTU (frames) setting set to Jumbo (9000). For a large frame to be transmitted intact from end to end, every component in the path must support that frame size. The switches, routers, and NICs from one end to the other must all support the same size of jumbo frame transmission for a successful jumbo frame communication session.

1. Open System Preferences, and then click Network. In the Network preferences panel, click the Solo10G adapter (Thunderbolt Ethernet, Slot *x*) in the left panel, and then click Advanced; a new panel appears.
2. In the Advanced panel, click Hardware. From the Configure drop-down menu, select "Manually". In the Speed drop-down menu, leave the setting at 10G... In the Duplex drop-down menu, select "full-duplex" (*not* "full duplex, flow-control"). In the MTU drop-down menu, select "Custom," and then enter "9000" in the box below.
3. When you've finished changing the settings, click OK.
4. Back in the main Network window, click Apply after you've completed changing the settings.

4

Basic Configuration Information—Windows

Configure the Solo10G adapter's settings using Windows Device Manager. You may locate the device in the Network adapters category, listed as Sonnet Solo 10G SFP+ Thunderbolt 3 Edition.

First Time Use—Windows

The first time you connect the Solo10G SFP+ Thunderbolt 3 Edition adapter to your computer, an *Approve New Thunderbolt™ Devices* window will appear. From the drop-down menu select Always Connect, and then click OK.

Basic Configuration Information—Linux

The steps necessary to configure the Sonnet adapter with your computer may vary based on the version of Linux running. Sonnet recommends using whatever method or tools you would normally use for configuring any onboard ports.

6

Additional Advice—Use in macOS Server Environment

If you're in a macOS server environment, you may need to take additional steps to maximize performance.

- If your server is running 10.13.6+ enable SMB protocol, and disable AFP protocol.
- If your server is running 10.12.6- enable AFP protocol, and disable SMB protocol.

5

Contacting Customer Service

The Sonnet Web site located at <https://www.sonnettech.com> has the most current support information and technical updates. Before contacting Customer Service, please check our Web site for the latest updates and online support files, and check this Quick Start Guide for helpful information.

Email support requests generally receive the fastest responses, and are usually processed within a 24-hour period during normal business hours, excluding holidays. When you contact Customer Service, have the following information available so the customer service staff can better assist you:

- Product name
- Computer model
- A System Report (macOS), or a Microsoft System Information MSINFO32 (Windows) report (Windows), along with a description of the issue(s) you are encountering with your device

If further assistance is needed, please contact **Sonnet Customer Service** at:

E-mail: support@sonnettech.com

Tel: 1-949-472-2772

(Monday–Friday, 9 a.m.–5 p.m. Pacific Time, excluding holidays)

Japan Customers

Contact Sonnet Customer Service Japan at:

E-mail: jp.support@sonnettech.com

7