

# OPERATING MANUAL

## FREELENSING CINE®



[freelsingcine.com](http://freelsingcine.com) | [contact@freelsingcine.com](mailto:contact@freelsingcine.com) | +34 917 865 627

 [@freelsingcine](https://www.instagram.com/freelsingcine) |  [Freelsing Cine](https://www.youtube.com/FreelsingCine)

Title	Page
<b>SETTING UP FREELENSING CINE®</b> .....	<b>4</b>
1 CAMERA PREPARATION .....	5
2 FIX THE CORRESPONDING CAMERA MOUNT TO THE BELLOWS .....	6
2.1 Alexa Mini LF mount placement .....	6
2.2 RED V-Raptor mount placement .....	7
2.3 RED DSMC2 mount placement .....	8
2.4 SONY Venice mount placement .....	9
3 MARRIAGE BETWEEN CAMERA & FREELENSING CINE® .....	10
3.1 Placing Freelensing Cine® on rods with the camera .....	10
3.2 Attaching the Alexa Mini LF mount .....	11
3.3 Attaching the RED V-Raptor mount .....	12
3.4 Attaching the RED DSMC2 mount and SONY Venice mount .....	13
3.5 Mounting the lens .....	14
3.6 Matching Freelensing Cine® and camera .....	15
4 FINAL ADJUSTMENTS .....	16
4.1 Mounting the lens .....	16
<b>WHAT MOVEMENTS DOES FREELENSING CINE® OFFER?</b> .....	<b>18</b>
5 Y-AXIS SHIFT OFFSET (max ± 25mm) .....	19
5.1 Movement Y-axis shift offset .....	19
6 X-AXIS SHIFT OFFSET (max ± 25mm) .....	22
6.1 Movement X-axis shift offset .....	22
7 Y-AXIS ROTATION (TILT-Y) (max ± 20°) .....	23
7.1 Movement Y-axis tilt rotation .....	23
7.2 Movement Y-axis tilt rotation (up to +20° and down to -20°) .....	24
8 X-AXIS ROTATION (SWING-X) (max ± 20°) .....	25
8.1 Movement X-axis swing rotation .....	25
8.2 Movement X-axis swing down to -20° and rotation (up to +20°) .....	26
9 Z-AXIS SHIFT OFFSET "COLLIMATION" .....	27
<b>OTHER IMPORTANT FEATURES FROM FREELENSING CINE®</b> .....	<b>28</b>
10 GAS SPRING REPLACEMENT .....	29
10.1 Gas Spring Change .....	29
11 COUNTERBALANCE PRESSURE CHANGE .....	30
12 LOCKS .....	31

13	MOTORIZATION.....	32
13.1	Gears for motorization: X rotation (x-Swing) .....	32
13.2	Gears for motorization: X-shift.....	33
13.3	Gears for motorization: Y rotation (Y-Tilt) .....	34
14	FIXING TO AVOID MOVEMENTS OR VIBRATIONS.....	35
14.1	Fixing for transportation .....	35
14.2	Fixing with Magic Arm .....	36
	<b>WARNINGS.....</b>	<b>37</b>

# SETTING UP FREELENSING CINE®

# OPERATING MANUAL

(v2.0)

## 1 CAMERA PREPARATION

Eliminate as many elements as possible so that the **camera can enter as naked as possible** and thus be free to make as many movements and displacements as possible.

**HEIGHT STANDARD → 19MM RODS.** The camera has to allow placing the **19mm rods** in its standard position and as flush as possible to the camera body. The camera must have the necessary **Risers** to reach the 19mm height of the 19mm studio, and the **Dovetail** must be centred<sup>1</sup>.

**Everything should be as centred and flushed as possible** to avoid any accessory limiting the movements of the Freelensing Cine®.

**For Alexa Mini LF, Sony Venice 1&2 and RED DSMC2** → Remove the PL or LPL mount that is placed on the camera body.

**For RED V-RAPTOR** → remove the lens cap, maintain the RF mount on the camera body.

Choose the appropriate camera mount<sup>2</sup> for the Freelensing Cine®:

- ALEXA MINI LF
- RED V-RAPTOR
- RED DSMC2
- SONY VENICE (1&2)

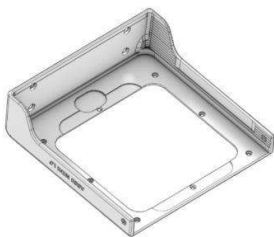

ALEXA MINI LF



RED V-RAPTOR

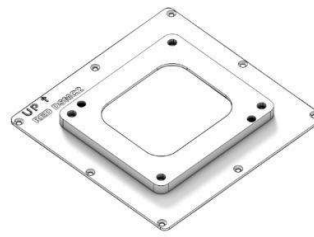

RED DSMC2



SONY VENICE (1&2)

<sup>1</sup> We are now working on adapters to be able to use the Freelensing Cine® in a 15mm Studio set-up.

<sup>2</sup> More will come in the future.

# OPERATING MANUAL

(v2.0)

## 2 FIX THE CORRESPONDING CAMERA MOUNT TO THE BELLOWS

The corresponding camera mount from the Freelensing Cine® should be fixed to the bellows with 8 x M2 flat screws.

Check the correct position → See detailed infographics below.

### 2.1 Alexa Mini LF mount placement

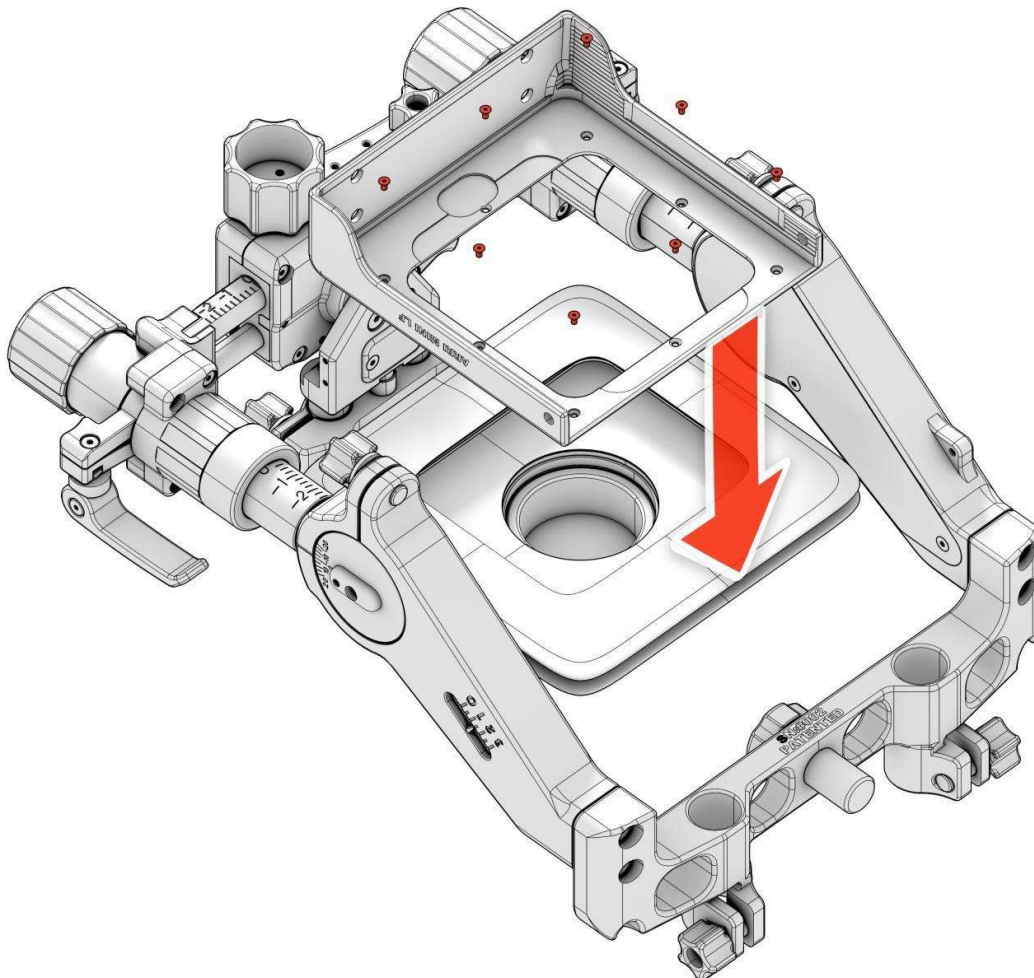

# OPERATING MANUAL

(v2.0)

## 2.2 RED V-Raptor mount placement

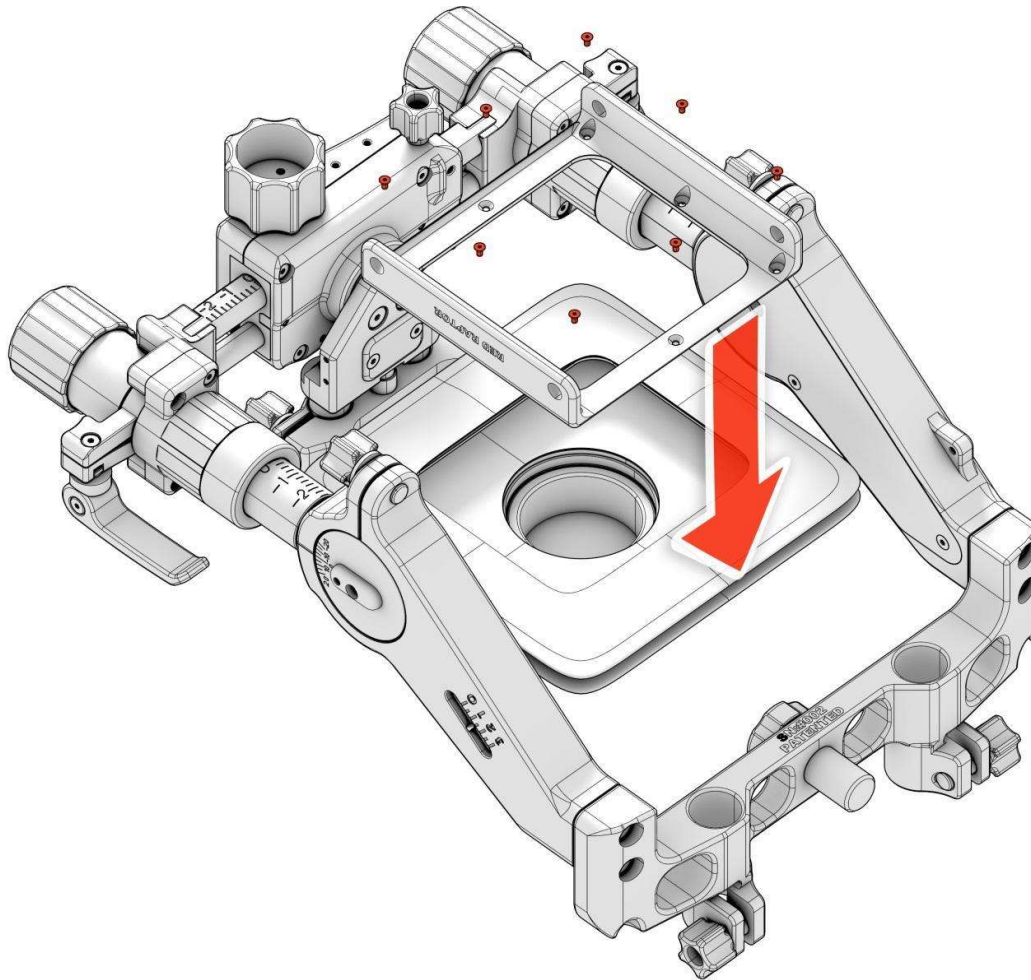

# OPERATING MANUAL

(v2.0)

## 2.3 RED DSMC2 mount placement

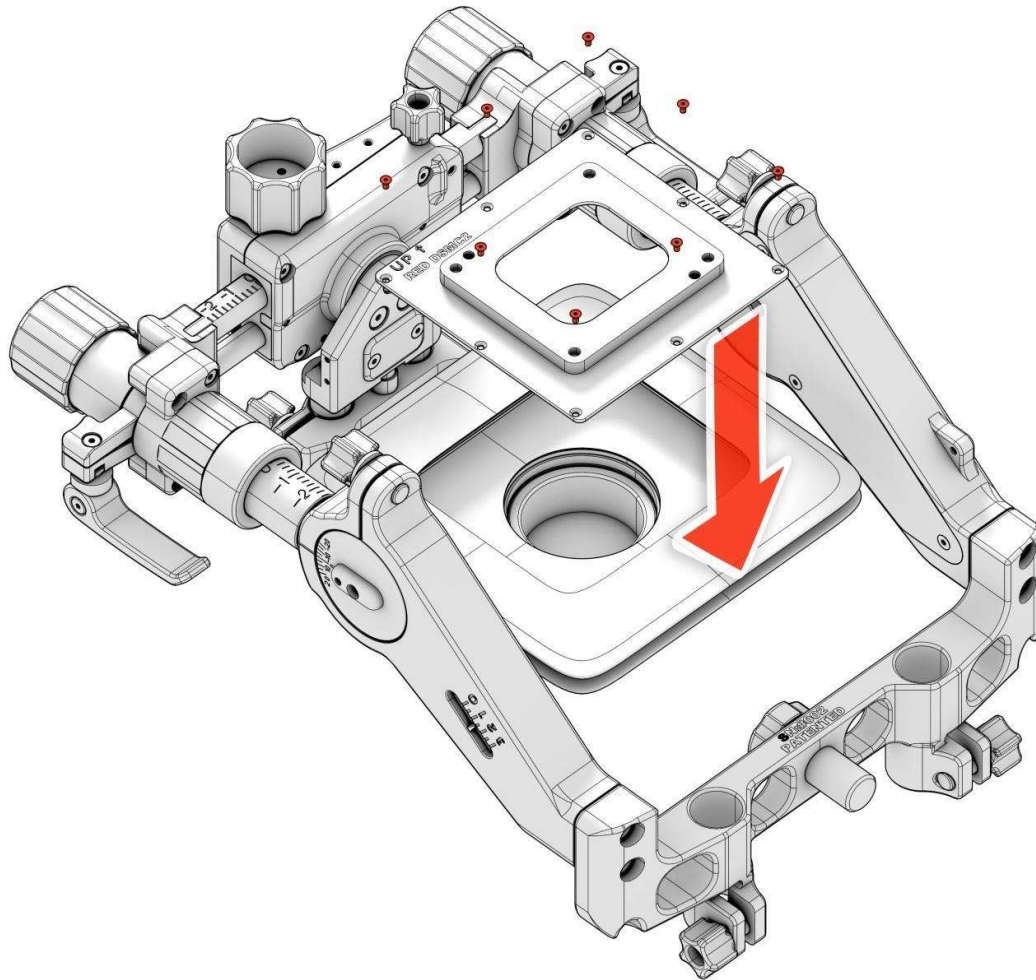

For SONY VENICE & RED DSMC2, when attaching the screws, the operator **must always** look at the "UP" side of the mount → and see the position of the upward arrow.

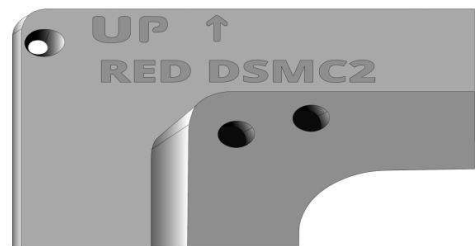

# OPERATING MANUAL

(v2.0)

## 2.4 SONY Venice mount placement

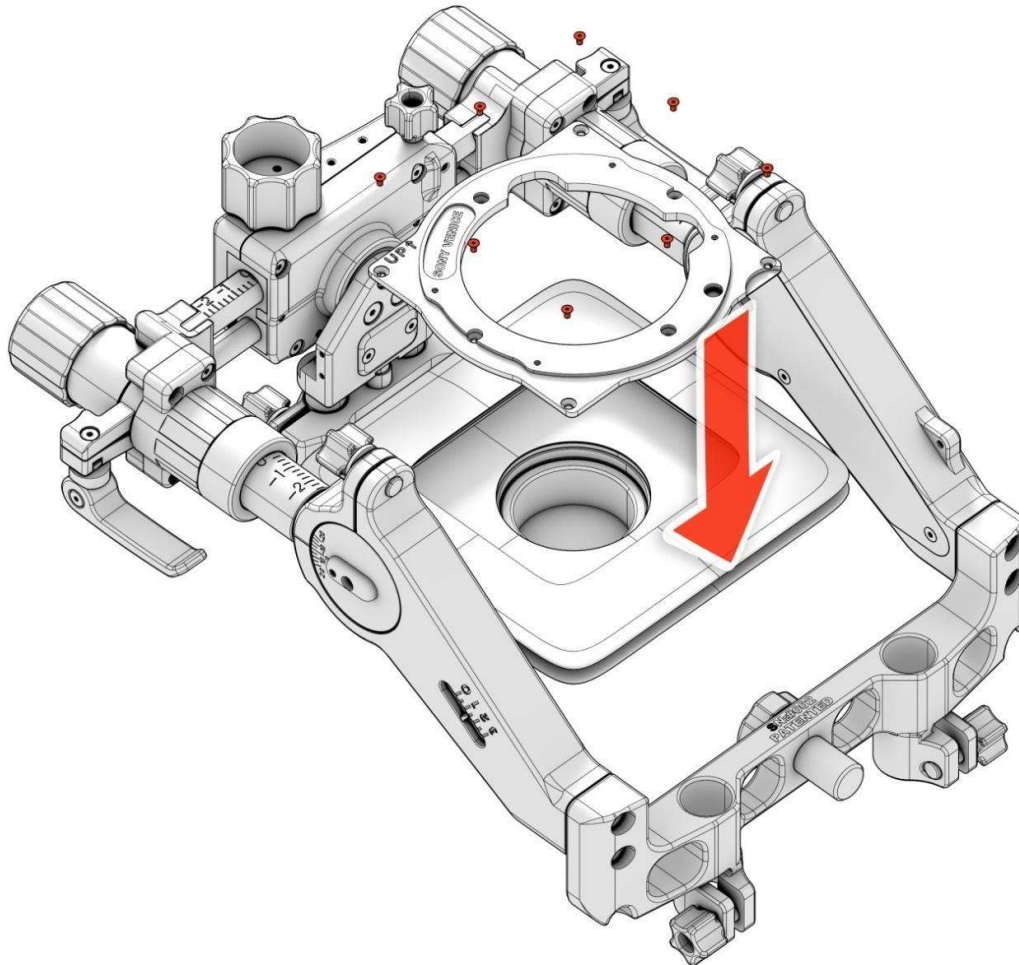

For SONY VENICE & RED DSMC2 when attaching the screws, the operator must always look at the "UP" side of the mount → and see the position of the upward arrow.



# OPERATING MANUAL

(v2.0)

## 3 MARRIAGE BETWEEN CAMERA & FREELENSING CINE®

Once the camera and Freelensing Cine® are ready (separately), the 19mm rods<sup>3</sup> attached to the camera will have to be inserted into the Freelensing Cine® or the other way around.

### 3.1 Placing Freelensing Cine® on rods with the camera

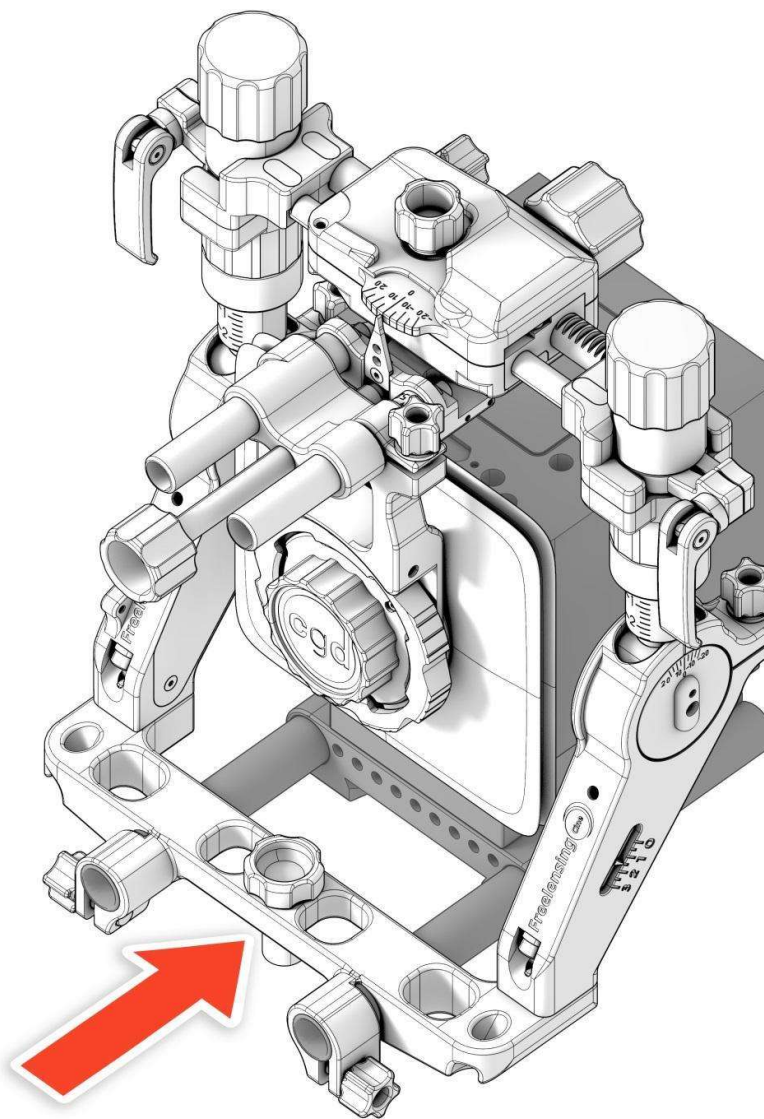

<sup>3</sup> Adapters for 15mm studio rods are in process.

# OPERATING MANUAL

(v2.0)

## 3.2 Attaching the Alexa Mini LF mount

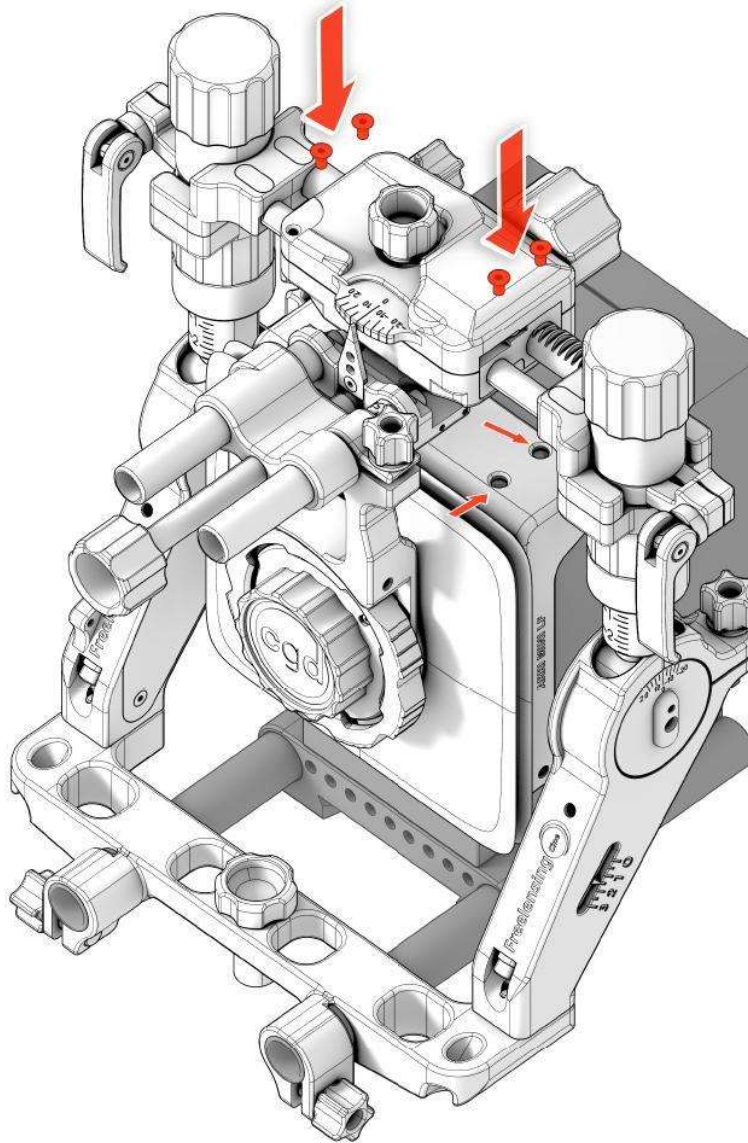

# OPERATING MANUAL

(v2.0)

## 3.3 Attaching the RED V-Raptor mount

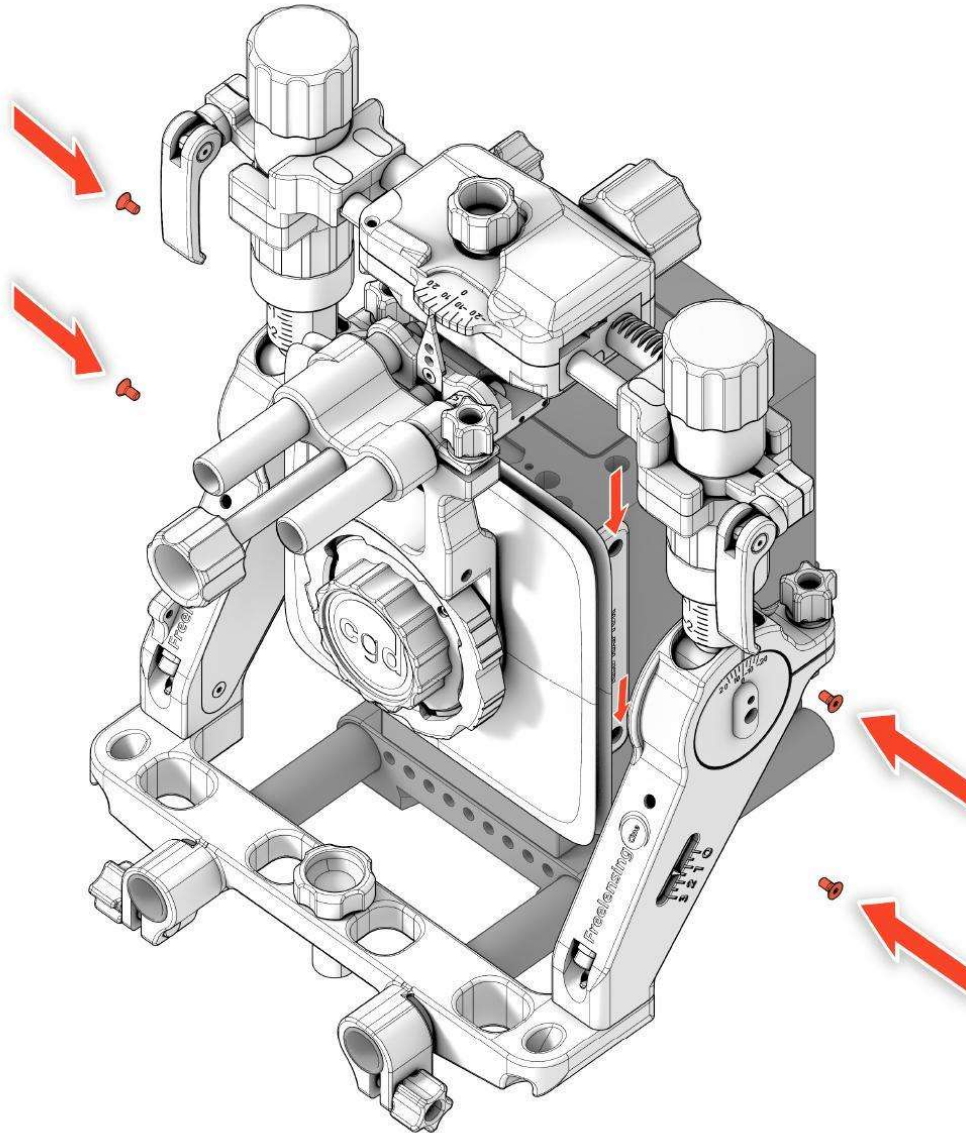

# OPERATING MANUAL

(v2.0)

## 3.4 Attaching the RED DSMC2 mount and SONY Venice mount

For RED DSMC2 & SONY VENICE → Place the camera mount (already installed in the bellows of the Freelensing Cine®), align it with the screws (must be inserted already) and tighten them in each of the corresponding holes of the camera → This adjustment will have to be made through the hole of the lens mount. The movement of the system will give us more mobility to make these adjustments.

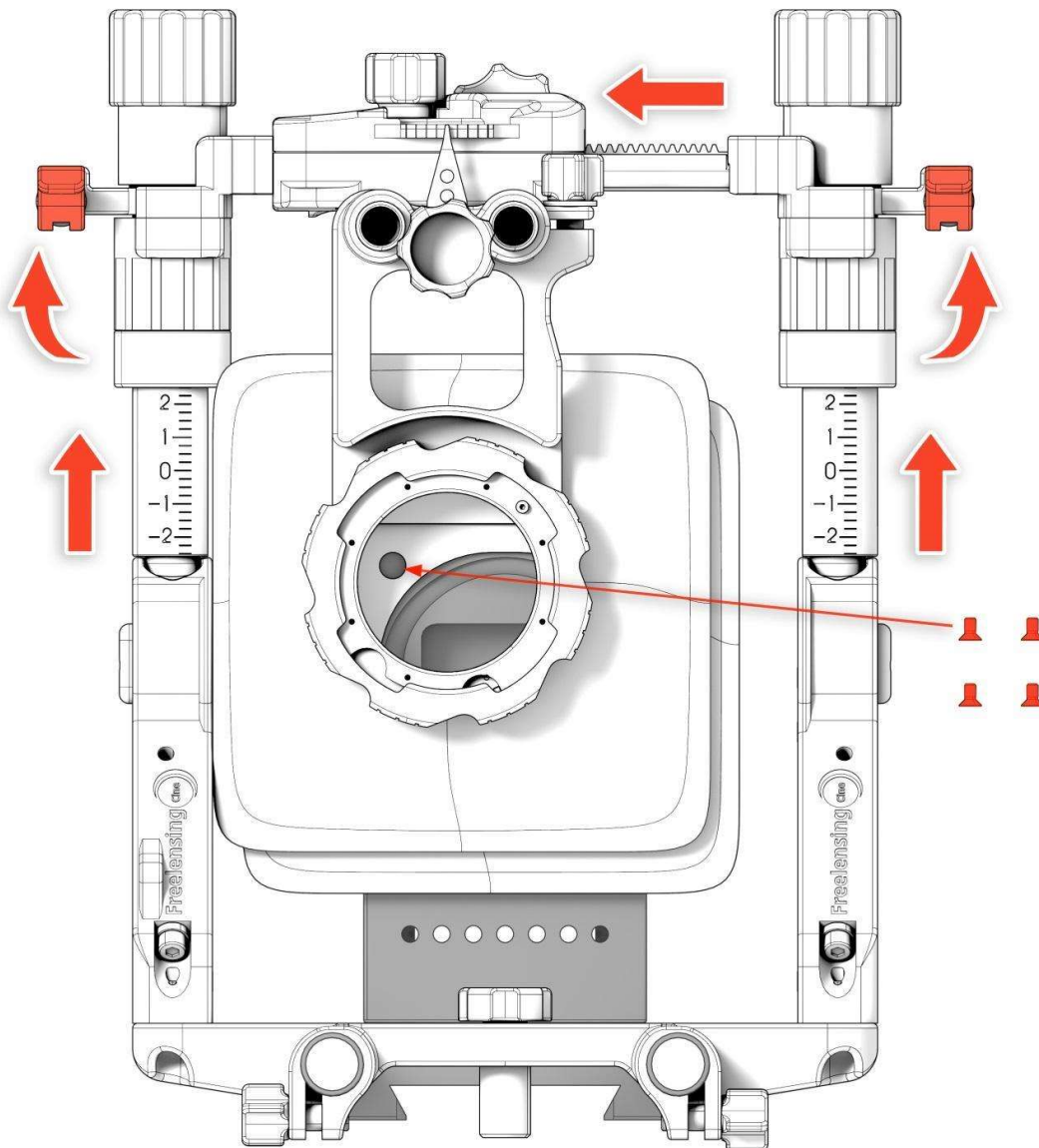

# OPERATING MANUAL

(v2.0)

## 3.5 Mounting the lens

Set the "collimation" Z-axis adjustment knob to 52mm PL<sup>4</sup> → final collimation will be made in the next steps. Check: 3.6 Matching Freelensing Cine® and camera and 4 Final adjustments.

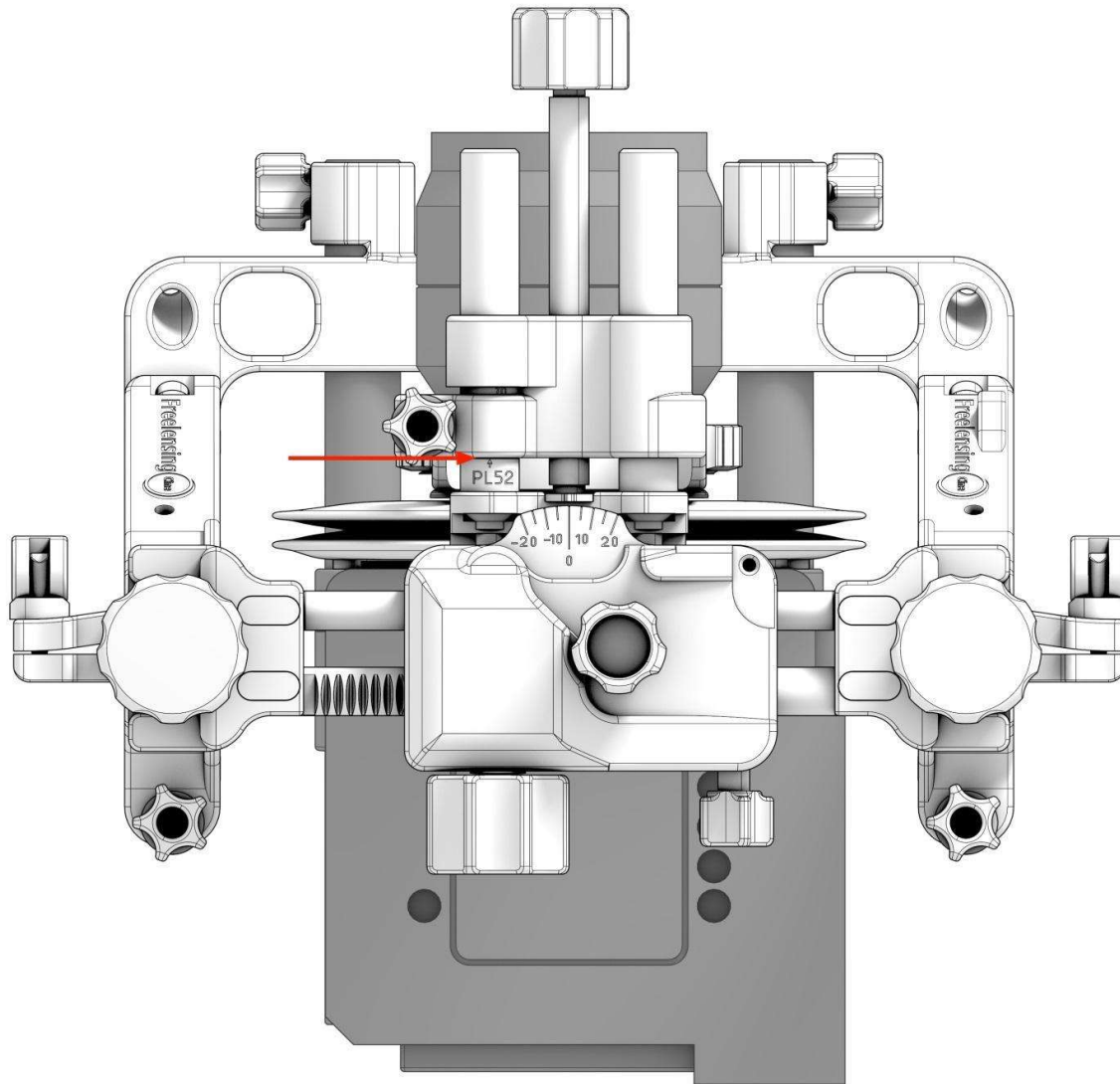

<sup>4</sup> 44mm for LPL mount (when ready).

### 3.6 Matching Freelensing Cine® and camera

Bring the **HOLES** on the **SIDES** of the **Freelensing Cine®** close to the **NODAL POINT MARK** on each of the cameras. To make sure we are in line with the focal plane<sup>5</sup> → look through the holes to make sure they are as aligned as possible to this point.

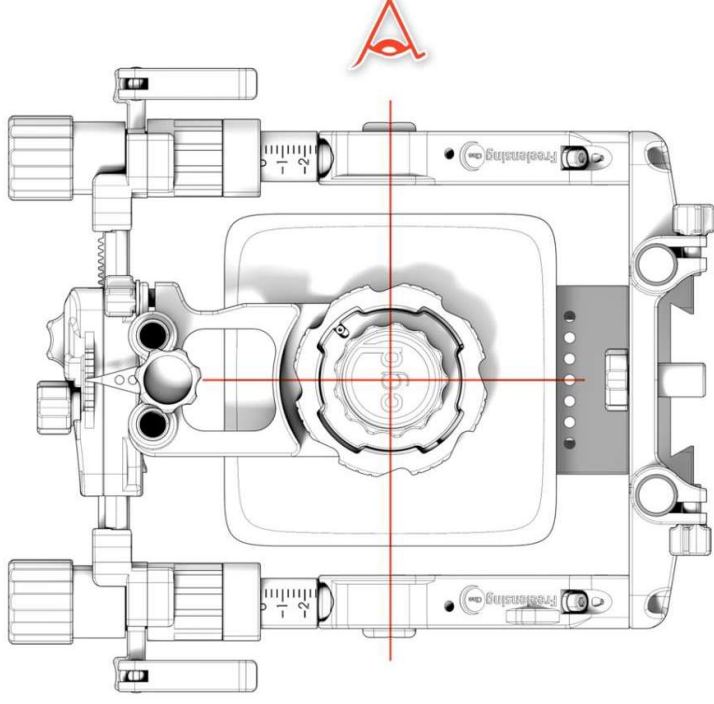
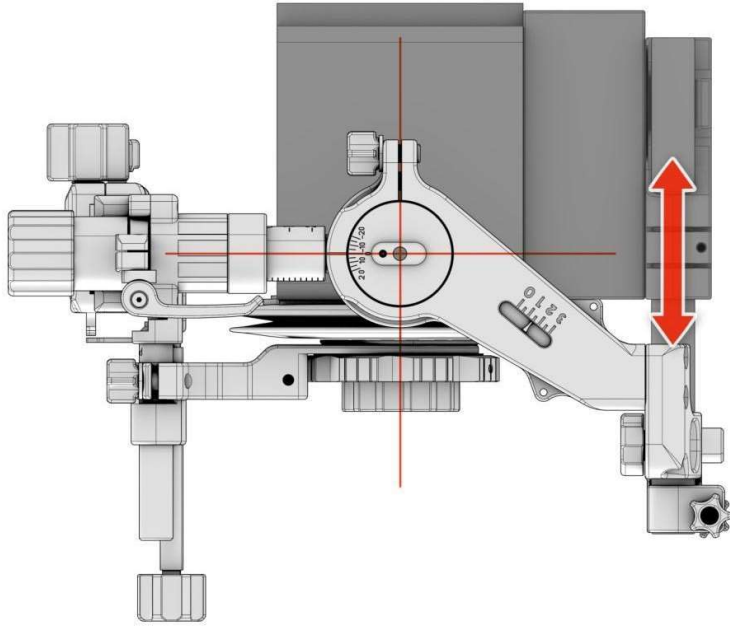

<sup>5</sup>This is just an approximation, in order to fix it, check point [4.1 Mounting the lens](#)  
All Rights Reserved | Freelensing Cine® is manufactured by CGD | [freelensingcine.com](http://freelensingcine.com)

## 4 FINAL ADJUSTMENTS

### 4.1 Mounting the lens

Set all Freelensing Cine® settings to "0" except Z-axis, already fixed at 52mm. Check **3.5 Mounting the lens.**

We fix all camera peripherals (rods, etc) and tighten the red 3/8 screw located above the serial number, inside a 3/8 hole.

We **finish adjusting** by moving the camera body closer or further away from the Freelensing Cine® until the object is sharp and in focus to the correct distance from the object. For example:

- We have a focus chart at 2 meters from the focal plane
- We place the lens at 2 meters mark
- We move the camera body over the 19mm rods and dovetail until the object is in focus
- We lock all the camera settings

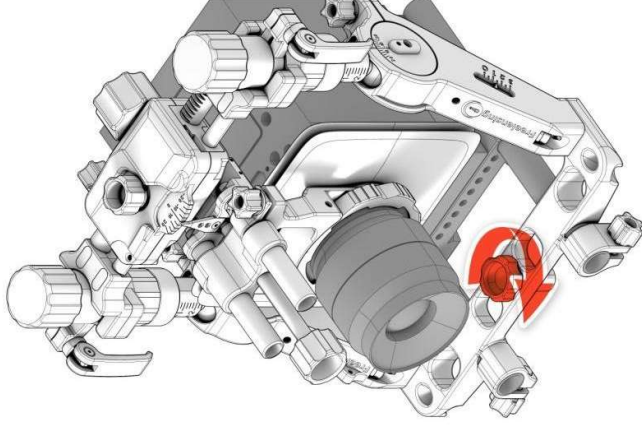
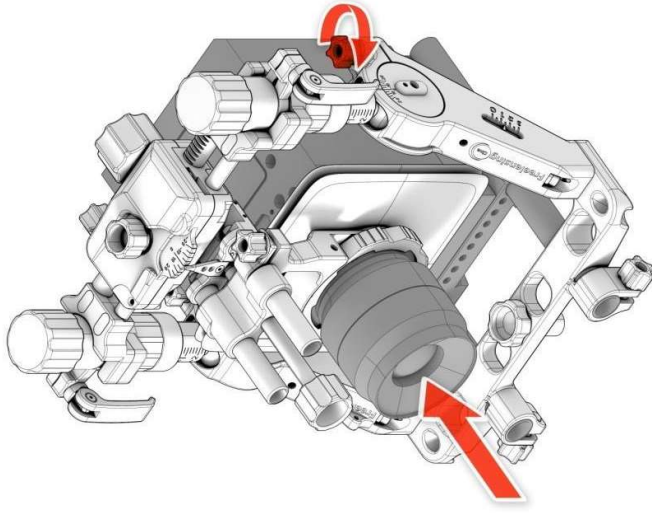

# OPERATING MANUAL

(v2.0)

As of this moment...

**FREE YOUR LENS, FREE YOUR MIND.**

# OPERATING MANUAL

(v2.0)

## WHAT MOVEMENTS DOES FREELENSING CINE® OFFER?

(\*) The max movements (mm or °) listed in the following pages will be reduced if there is a combination of movements.

(\*\*) The max movements (mm or °) the system offers will depend on the camera and lens mount, and the physical limitations these may have.

## 5 Y-AXIS SHIFT OFFSET (max ± 25mm)

Depending on the weight hanging from the lens mount of the system, there are interchangeable Gas Springs, check point 10 "Gas spring replacement".

### 5.1 Movement Y-axis shift offset

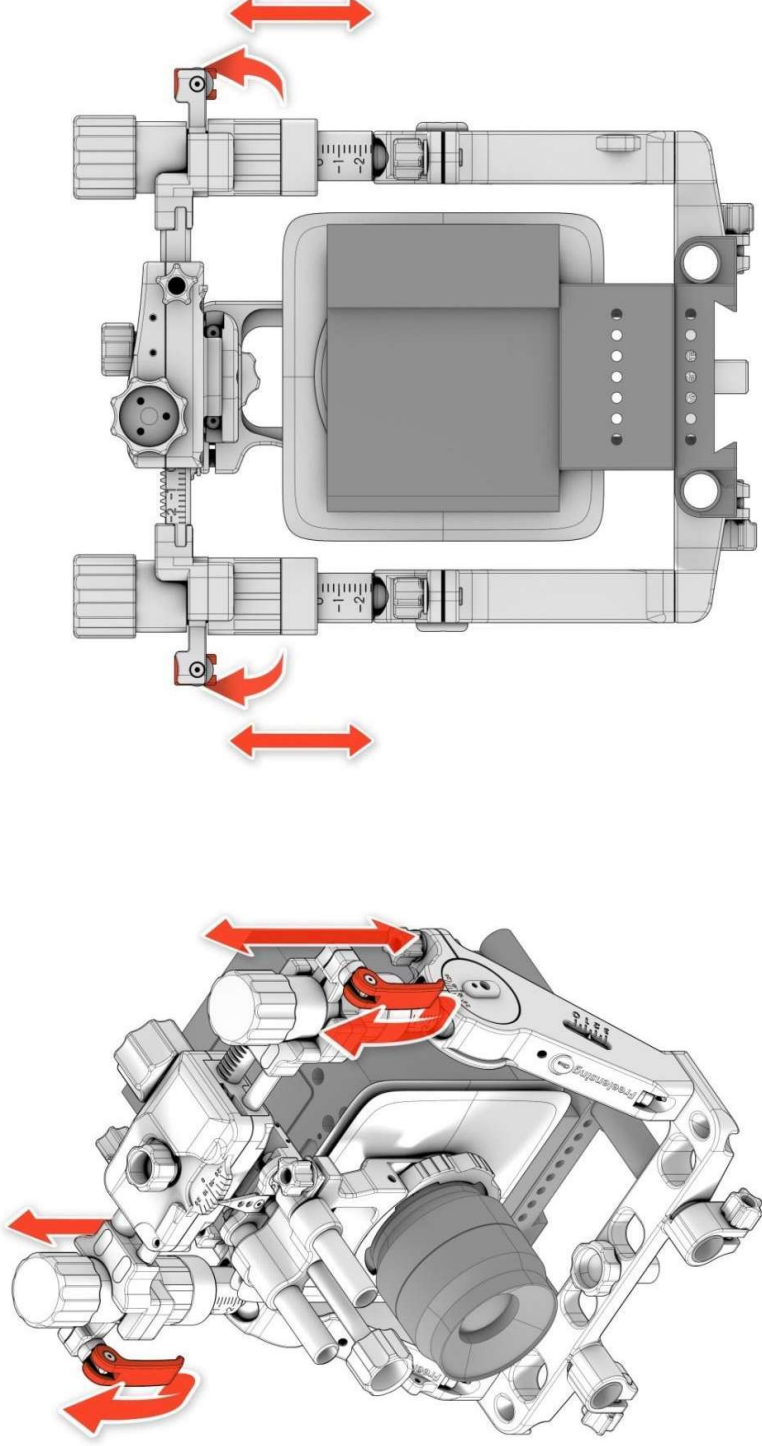

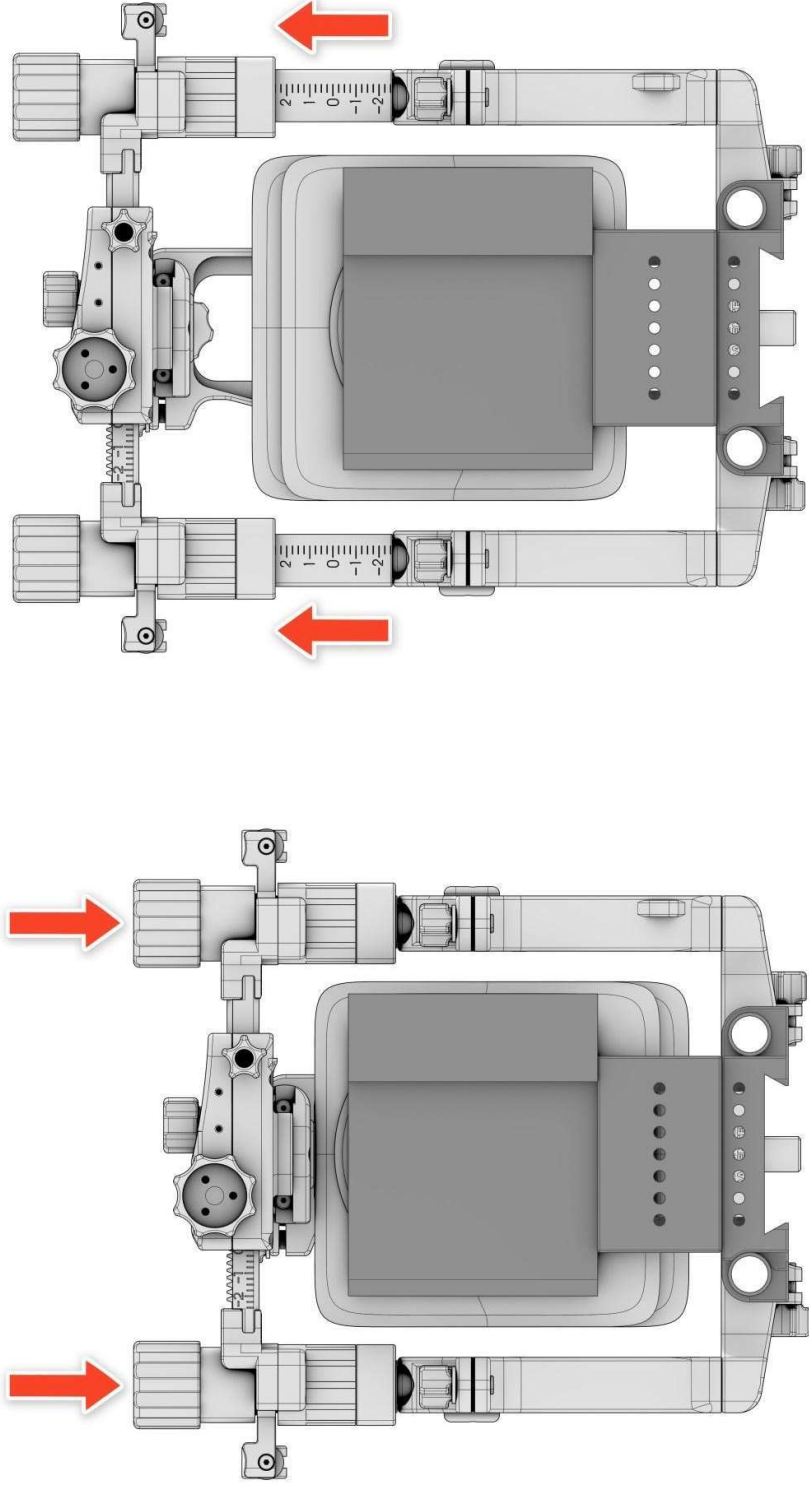

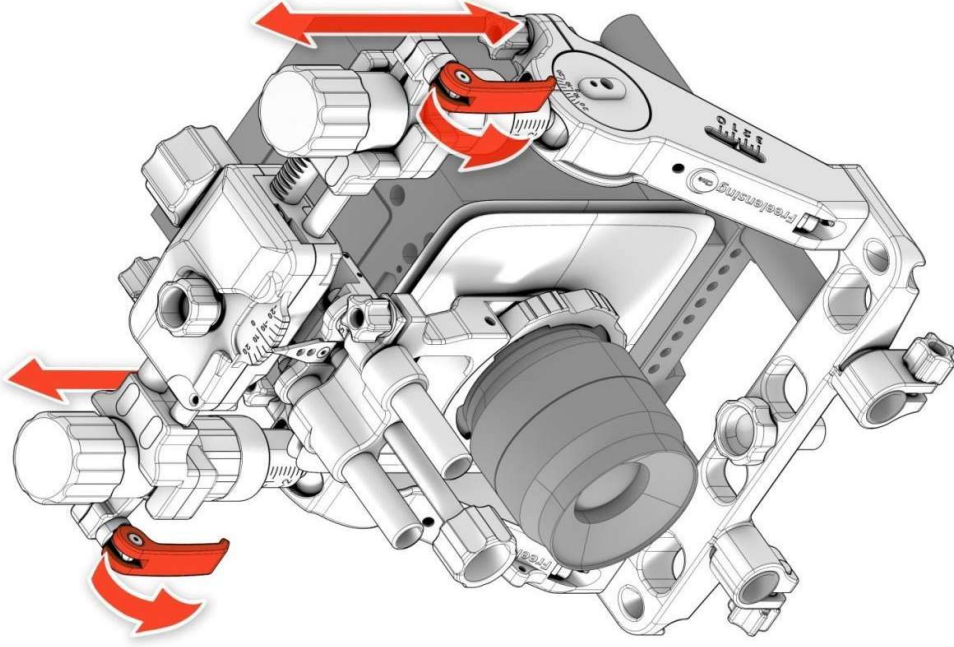

**ADJUSTING SCREW (M3)** from the locking cam for Y-shift (pay special attention to the pressure of this screw, as it could loosen due to vibrations during transport). Adjust without the lens on and with 3kg gas spring.

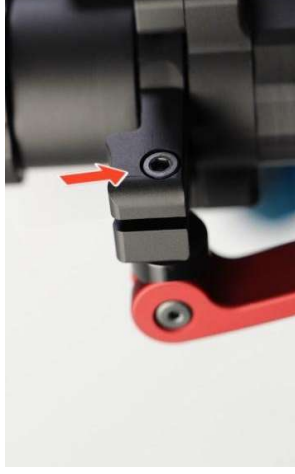

## 6 X-AXIS SHIFT OFFSET (max ± 25mm)

### 6.1 Movement X-axis shift offset

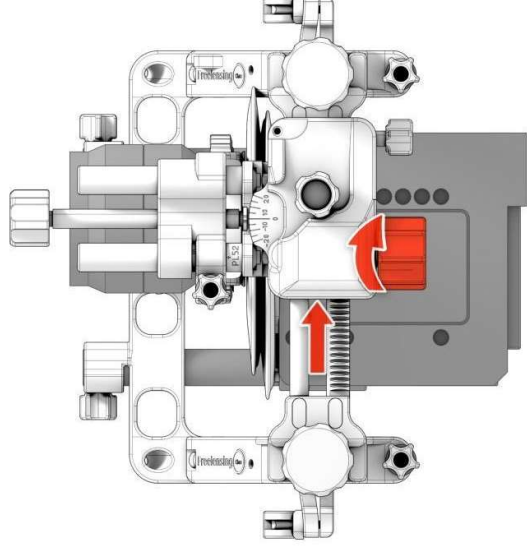
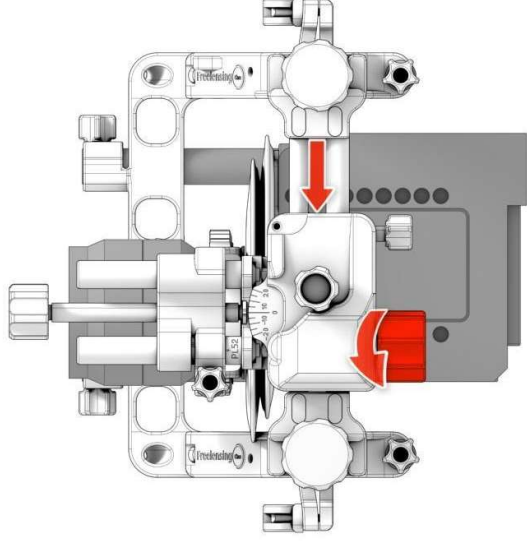
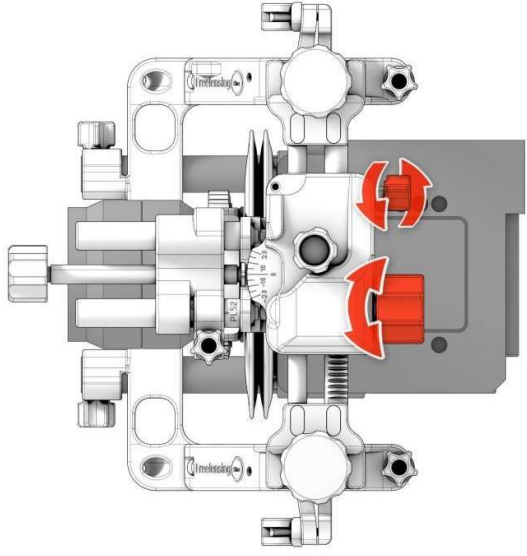

SCROLL KNOB for X-shift

## 7 Y-AXIS ROTATION (TILT-Y) (max ± 20°)

### 7.1 Movement Y-axis tilt rotation

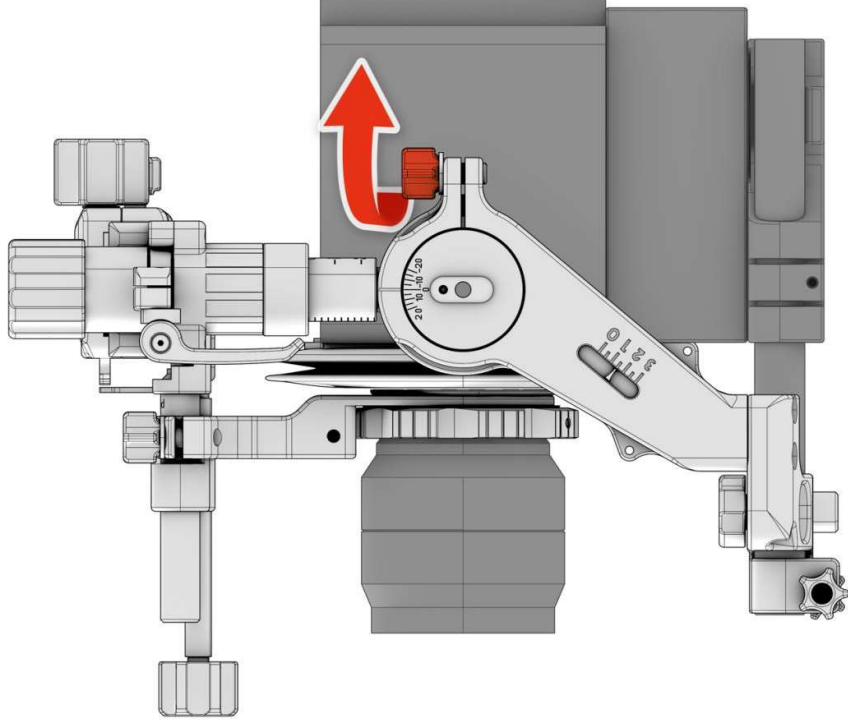

LOCKING SCREW for Y rotation



Freelensing Cine®  
**OPERATING MANUAL**  
(v2.0)

**7.2 Movement Y-axis tilt rotation (up to +20° and down to -20°)**

Depending on the counterbalance needed to balance the lens there is the possibility to change the pressure of the counterbalance. Check point 11 "Counterbalance pressure change".

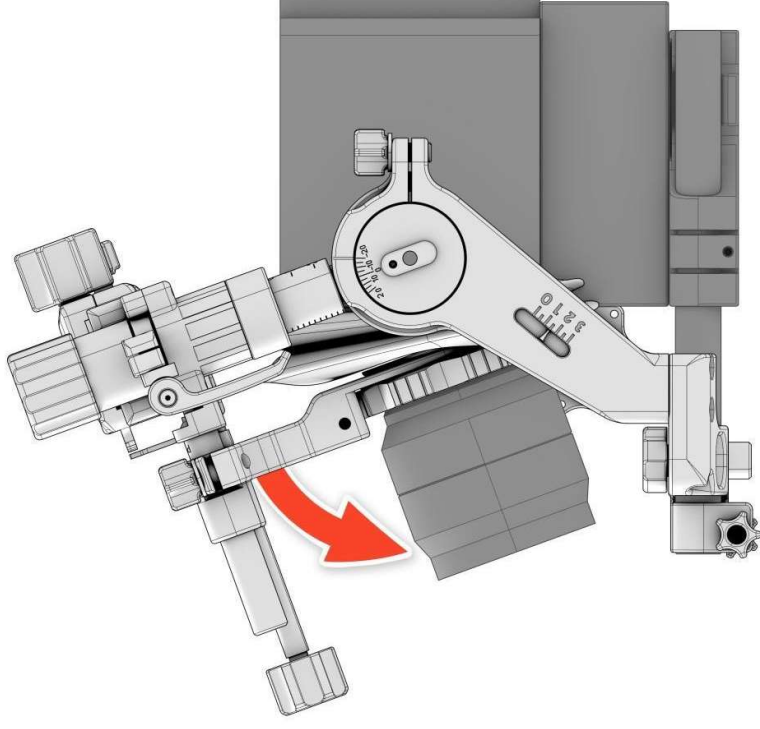
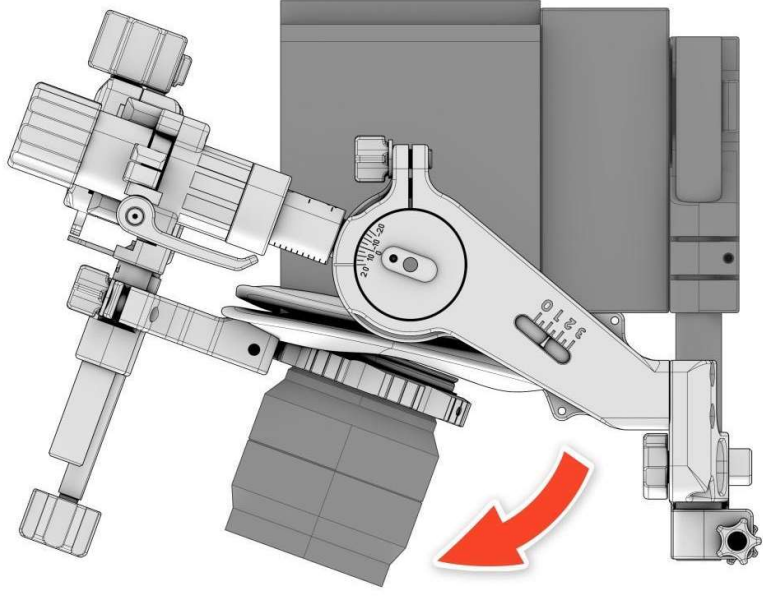

## 8 X-AXIS ROTATION (SWING-X) (max $\pm 20^\circ$ )

### 8.1 Movement X-axis swing rotation

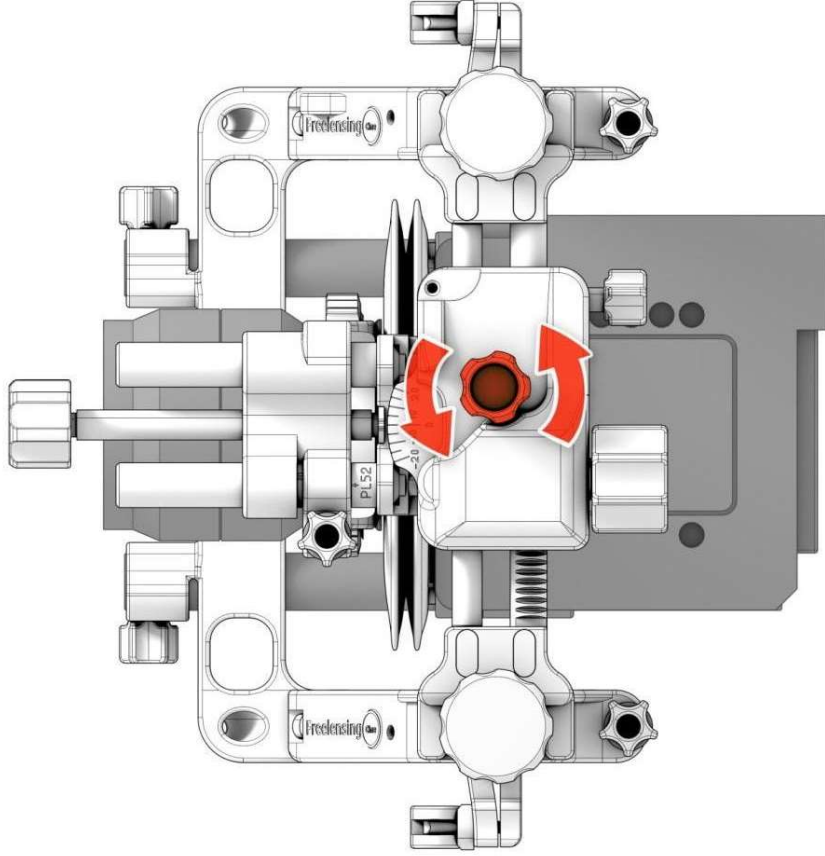

LOCKING SCREW for X-rotation



Freelensing Cine®  
**OPERATING MANUAL**  
(v2.0)

8.2 Movement X-axis swing down to -20° and rotation (up to +20°)

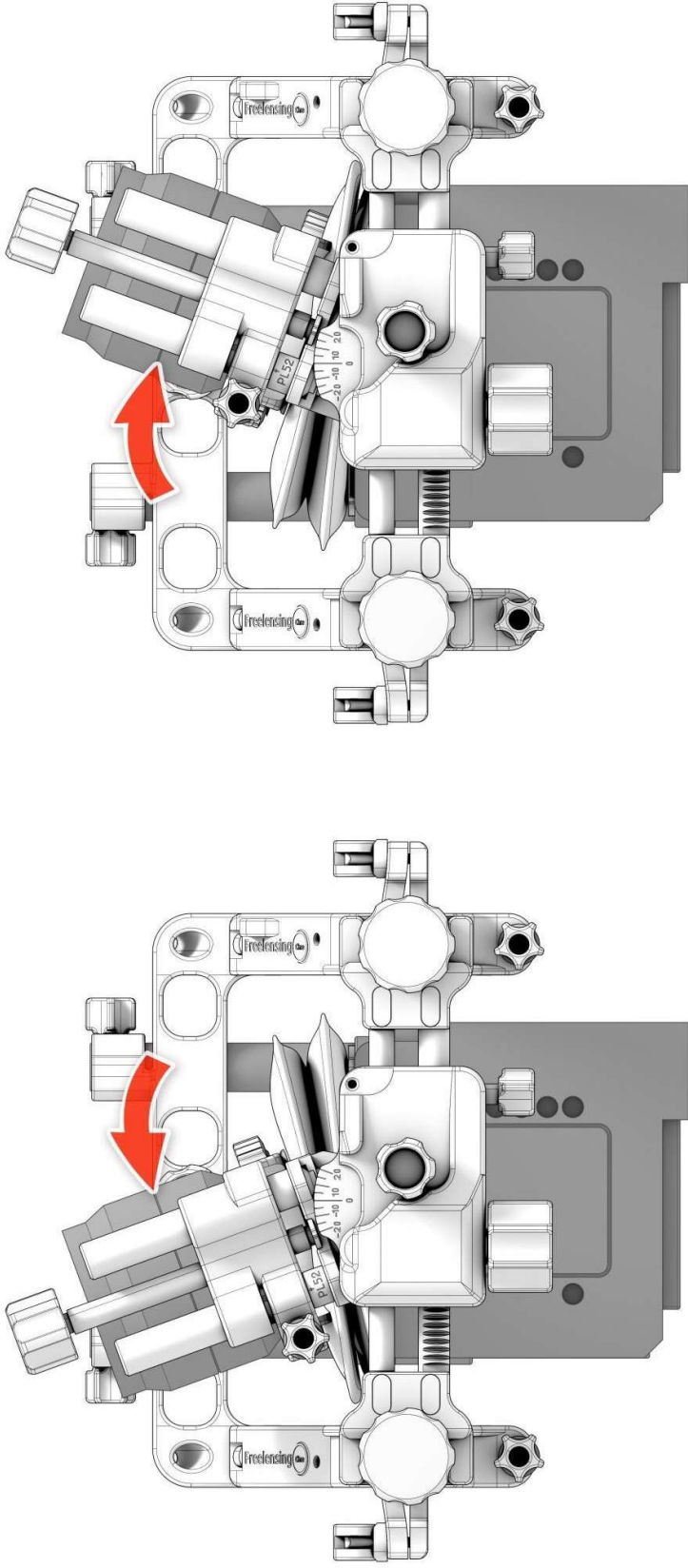

## 9 Z-AXIS SHIFT OFFSET "COLLIMATION"

Shift in Z → macro positions and expansion of lens focus ring travel.

- LPL 44mm (work in progress)
- PL 52mm

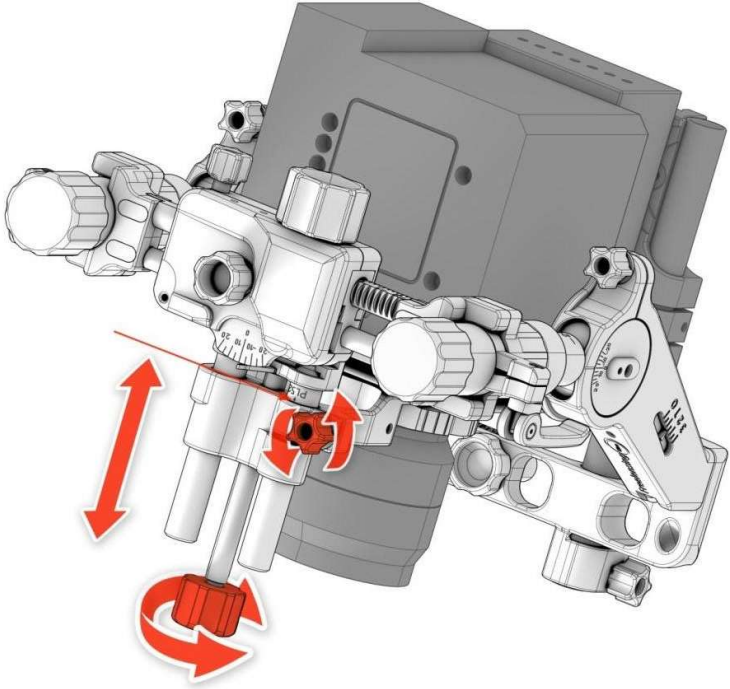

LOCKING SCREW for Z-shift "collimation"



ADJUSTMENT KNOB for Z-shift "collimation"

# OPERATING MANUAL

(v2.0)

## OTHER IMPORTANT FEATURES FROM FREELENSING CINE®

# OPERATING MANUAL

(v2.0)

## 10 GAS SPRING REPLACEMENT

To make the most out of Y-AXIS SHIFT OFFSET (point 5) there are interchangeable **GAS SPRINGS** that must be changed depending on the weight hanging from the system:

- **Blue** → around 2kg
- **Red** → around 3k
- **Black** → around 4kg

### 10.1 Gas Spring Change

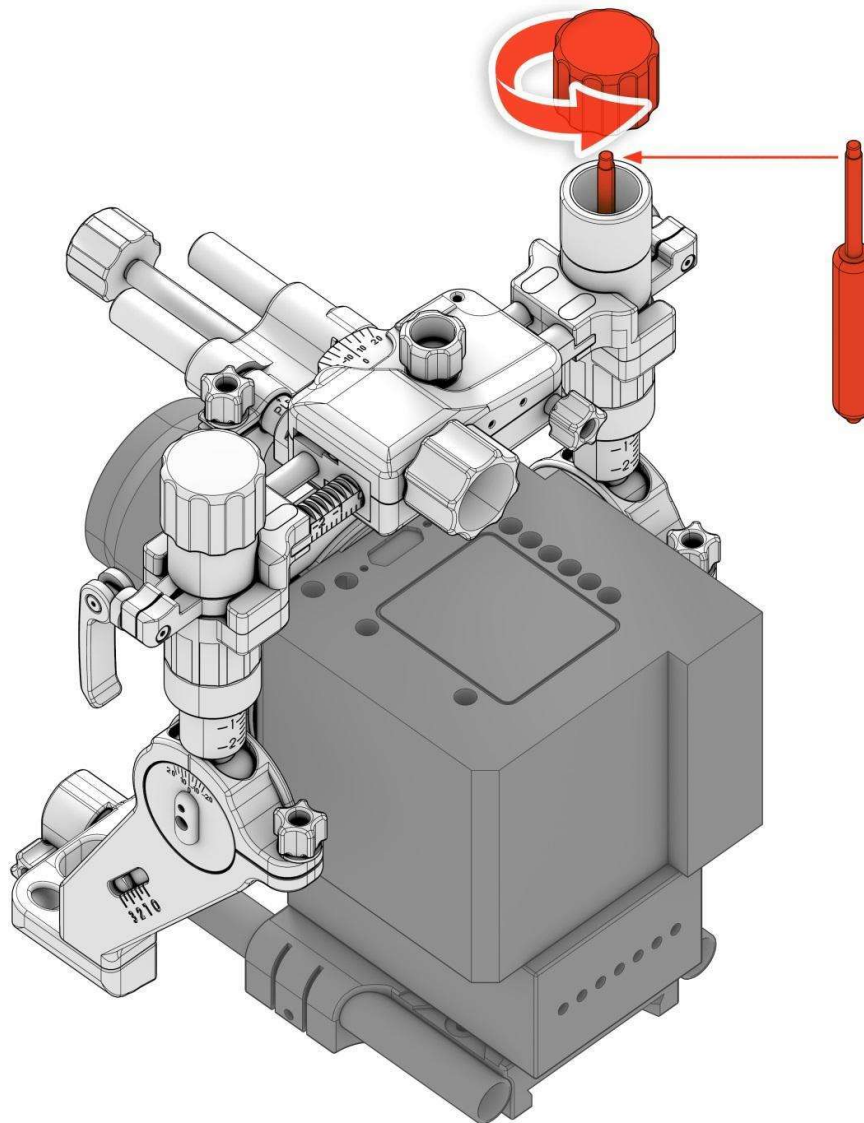

## 11 COUNTERBALANCE PRESSURE CHANGE

Adjust the counterbalance for the Y-axis Tilt rotation, it will depend on the weight in front of the lens mount (lens, mattebox, etc) and the gas spring inserted in the system. See point 7 Y-AXIS ROTATION (TILT-Y).  
**ALLEN WRENCH M4** → To be adjusted to compensate for the weight of the lens with the counterbalance, with 0 being the minimum force and 3 being the maximum force.

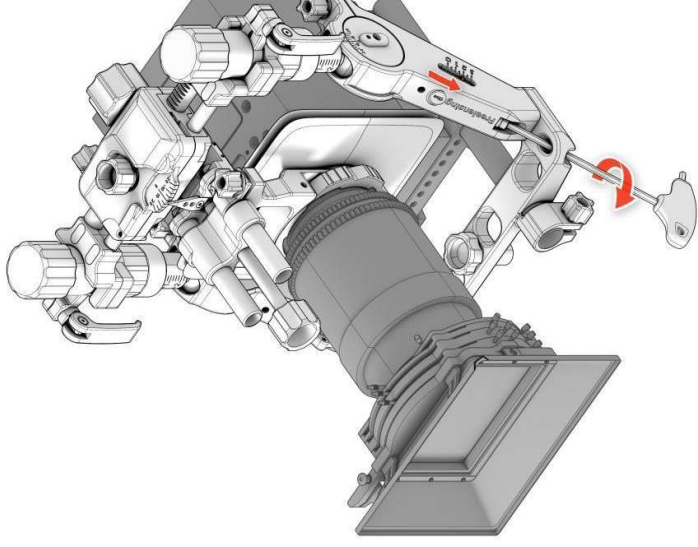
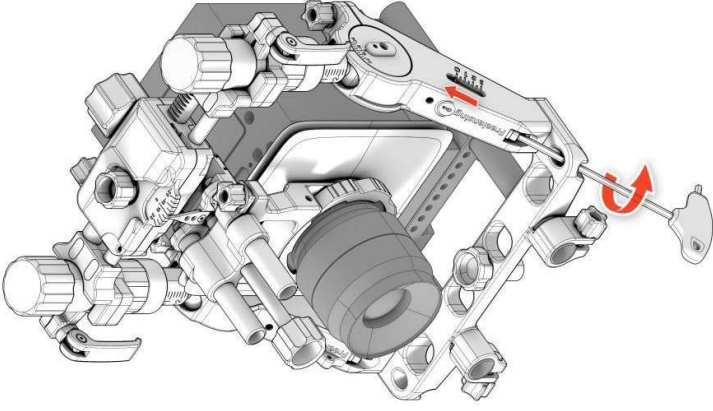

## 12 LOCKS

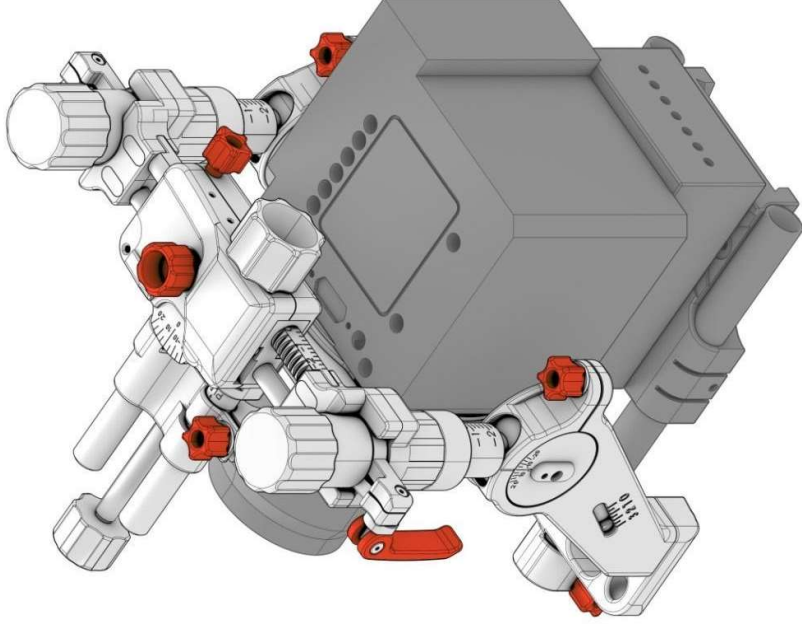
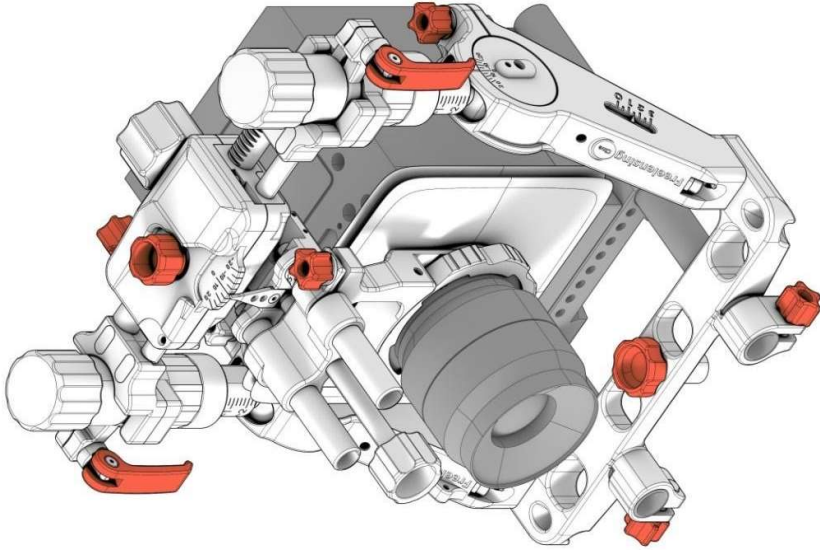

## 13 MOTORIZATION

### 13.1 Gears for motorization: X rotation (x-Swing)

Motorizable with standard motors from Follow Focus (0.8 gear).

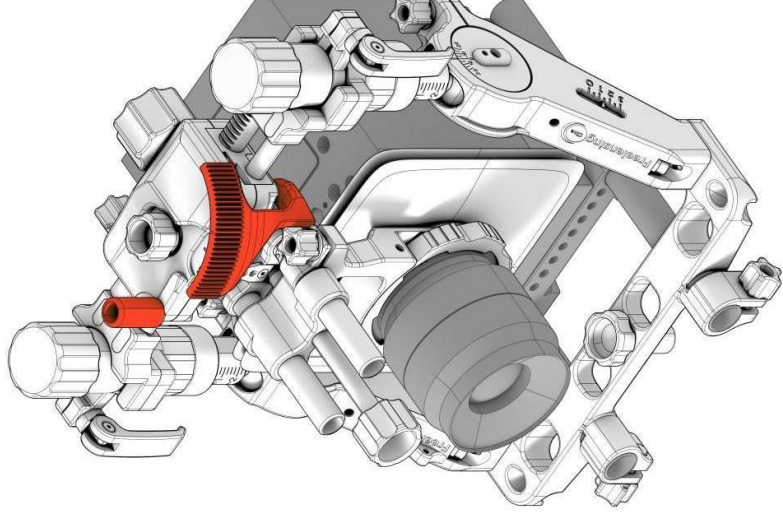
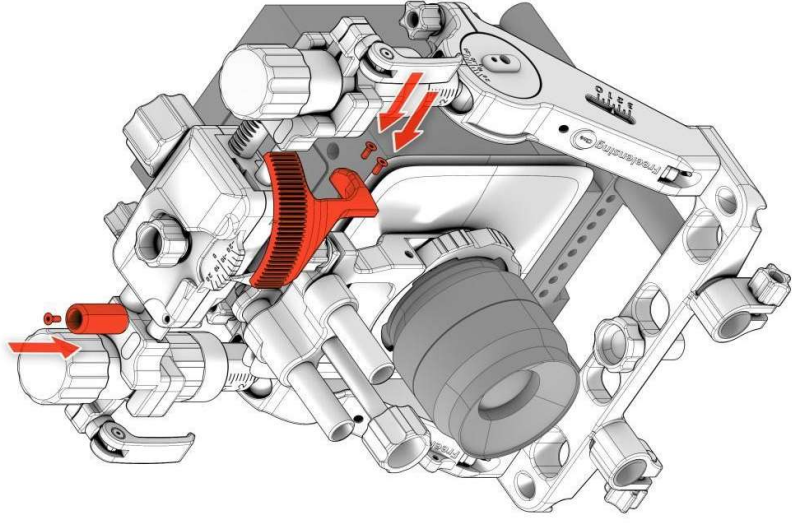

## 13.2 Gears for motorization: X-shift

Motorizable with zoom fluid or motors with enough torque (0.8 gear).

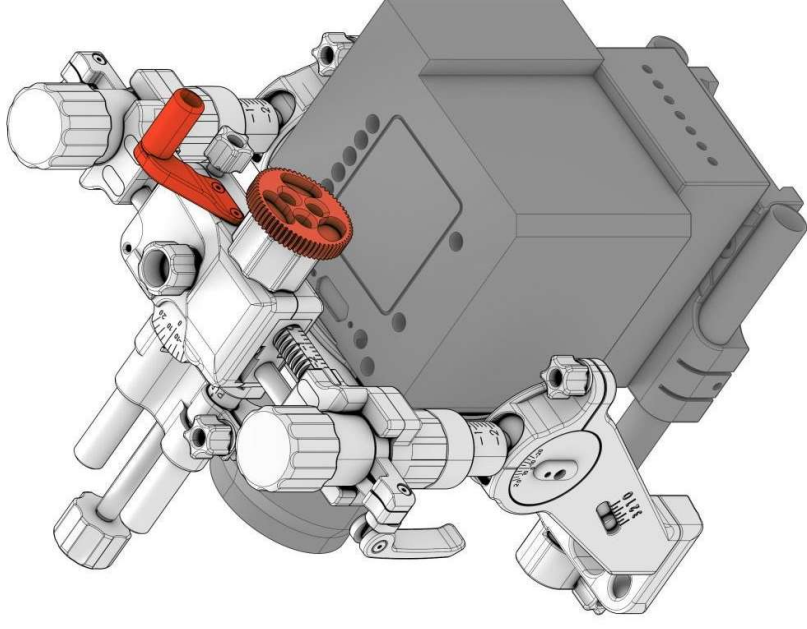
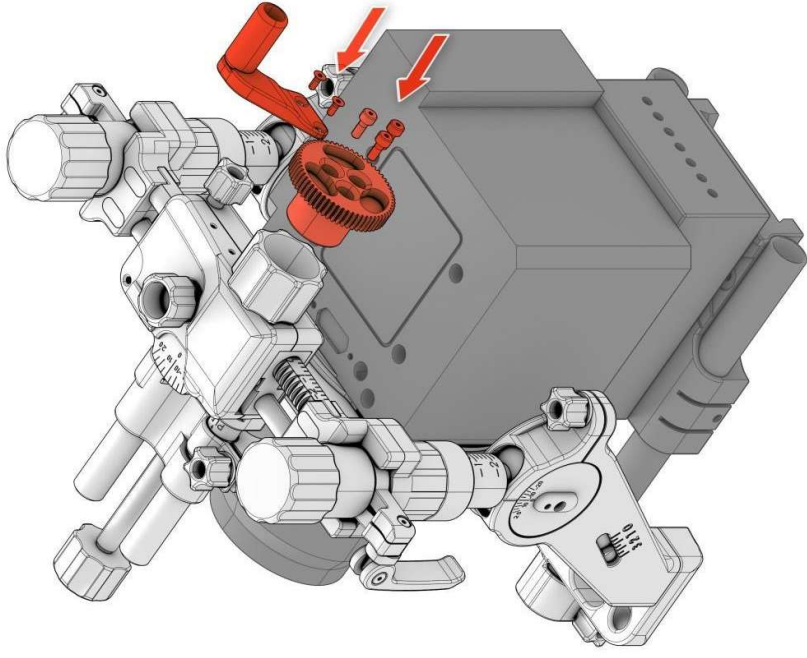

### 13.3 Gears for motorization: Y rotation (Y-Tilt)

Motorizable with zoom fluid or motors with enough torque (0.8 gear).

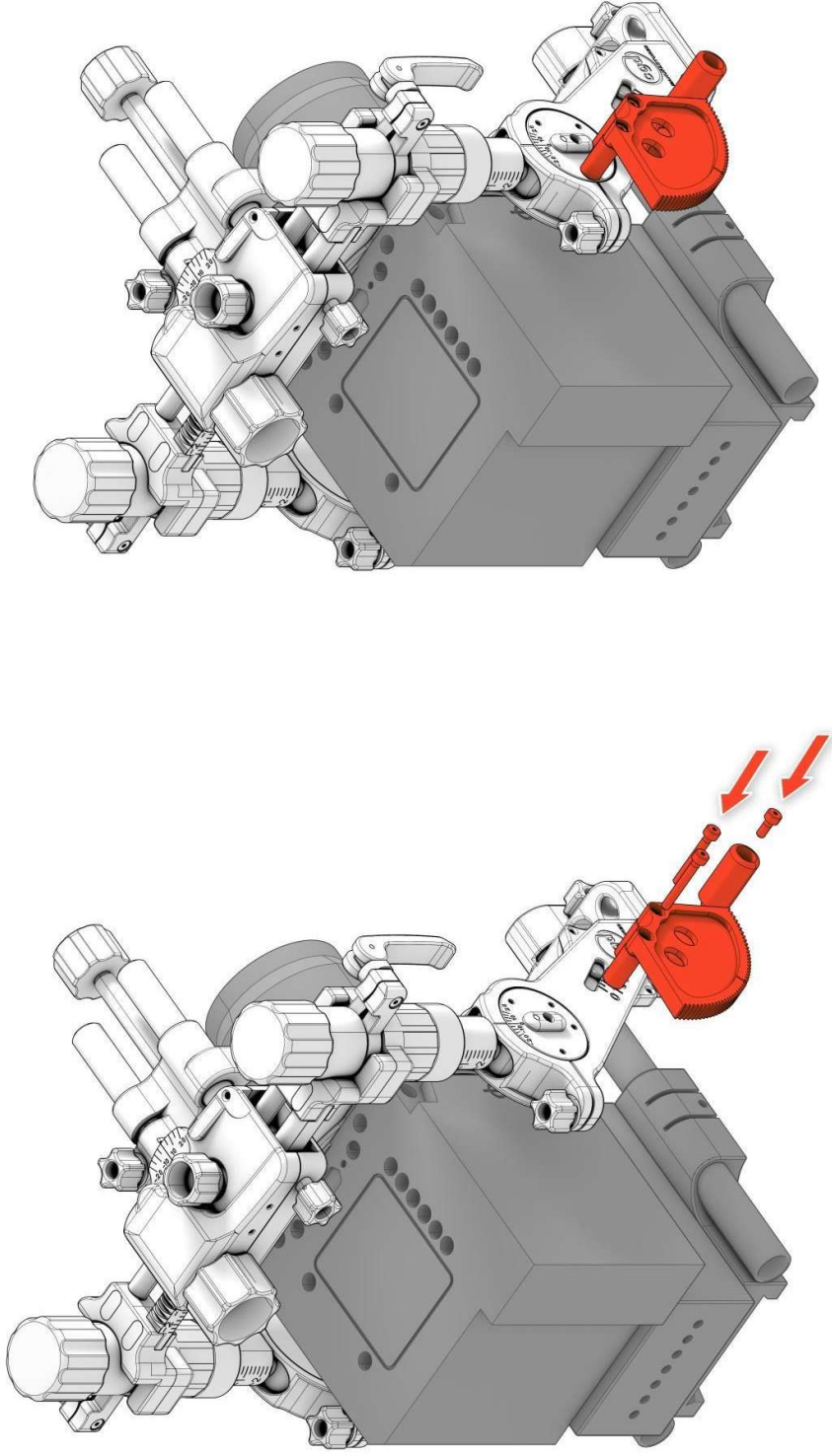

# OPERATING MANUAL

(v2.0)

## 14 FIXING TO AVOID MOVEMENTS OR VIBRATIONS

### 14.1 Fixing for transportation

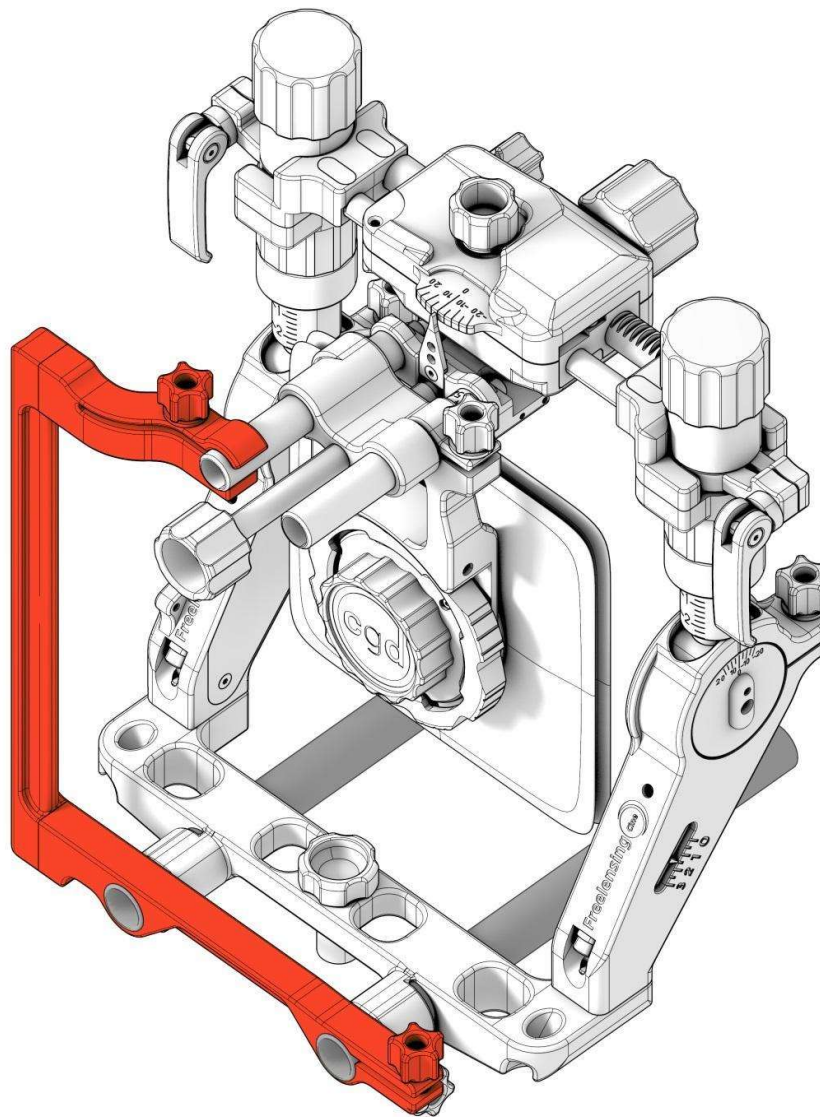

Use the cage with U shape included in the kit to fix the system and avoid vibrations. The system will suffer due to vibrations during transportation if the U-cage is not attached.

## 14.2 Fixing with Magic Arm

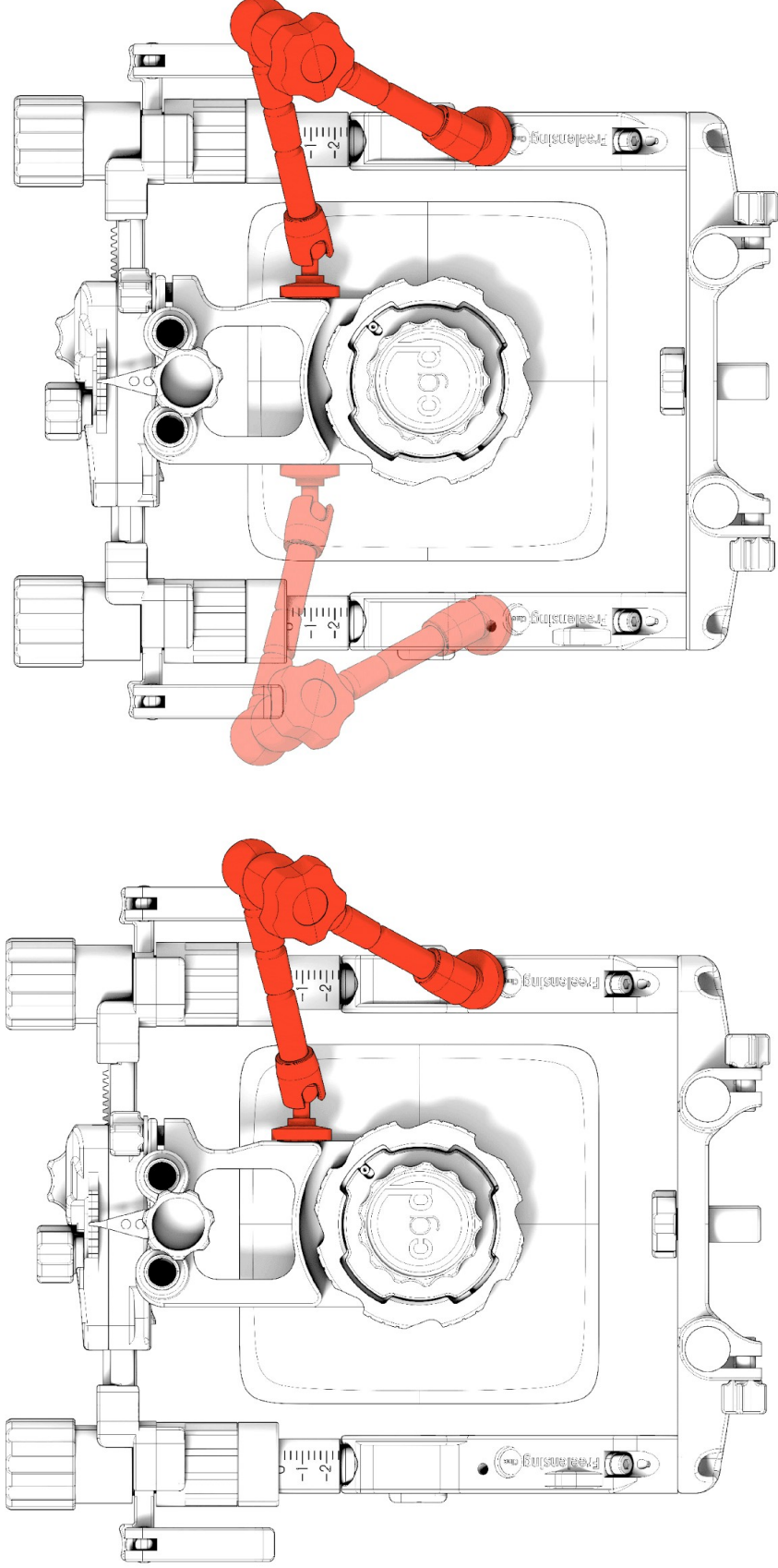

# OPERATING MANUAL

(v2.0)

## WARNINGS

# OPERATING MANUAL

(v2.0)

- Maximum weight suspended from the lens mount: 4 kg (8.81 lbs→ including lens, mattebox, motors and/or any other accessory to be placed in front of the system.
- Do not hold the upper part of the Freelensing Cine® (especially with the camera on) UNDER ANY CIRCUMSTANCES → it can lead to breakage of the system, as well as the fall of the complete camera equipment → it is designed to withstand the load of the lenses in the established range (max 4 kg).
- To change it or to hold it by the side arms (where it says FREELENSING CINE®).
- Vibrations induced in the system can affect the image.
- Do not exert force if you feel resistance in any position.
- The Freelensing Cine® should always be positioned vertically and upwards, without inverting or turning it upside down. This may cause deterioration of the product.
- For 9:16 or vertical perspective images, only rotate the camera while keeping the system in vertical position, i.e.: lay the camera inside the system.
- To store the Freelensing Cine® it is recommended to lock the locks in these positions:
  - Y-axis at its maximum travel
  - X-axis → centered
  - Rotation of X at 0°
  - Rotation of Y at +20°
- To change the lens, it is advisable to lock the TILT of the Y axis (vertical rotation).
- Operating temperature of use: between 0°C and 40°C avoiding direct sun, dust, rain, ice. Storage temperature between -10°C and + 50°C avoiding direct sunshine.
- Avoid corrosive agents, both basic and acidic.

# OPERATING MANUAL

(v2.0)

- Do not hit.
- Use the tools provided with the system.
- Always supervise all the axes and their fixation.
- The camera must be correctly fixed and centered with respect to the 19mm rod BridgePlate so that the lens is placed in the correct position with respect to the Freelensing Cine® marks<sup>6</sup>.
- Keep the complete image in the projection circle, avoid split images (image circle and black) with shifting movements.
- Lens elements protruding into the sensor from the mount must be carefully analyzed and the user is responsible for any damage to the lens.
- In the event of any resistance to movement, abstain from forcing it and/or continuing to exert pressure.
- Before moving the camera it is advisable to keep the System locked.
- Do not grease.

<sup>6</sup>We are now working on adapters to be able to use the Freelensing Cine® in a 15mm Studio set-up.  
All Rights Reserved | Freelensing Cine® is manufactured by CGD | [freelensingcine.com](http://freelensingcine.com)

# OPERATING MANUAL

## FREELENSING CINE®



[freelensingcine.com](http://freelensingcine.com) | [contact@freelensingcine.com](mailto:contact@freelensingcine.com) | +34 917 865 627

[@freelensingcine](#) | [Freelensing Cine](#)