

iCON

CUBE Series

USB Recording Audio Interface



Cube

2-In / 2-Out Recording USB Interface

Cube Pro

4-In / 4-Out Recording USB Interface

Cube G

4-In (1 Mic/1 Guitar) / 4-Out Recording USB Interface with S/PDIF and MIDI I/O

Cube Mini

Compact 2-In (1 Mic + Switchable Mic/Guitar In) / 2-Out Recording USB Interface





Cube 4Nano

4-In / 4-Out with +48V Phantom Power Recording USB Interface

Cube DJ

4-In / 4-Out DJ Recording USB Interface



	<p>CAUTION</p> <p>RISK OF ELECTRIC SHOCK DO NOT OPEN RISQUE DE CHOC ELECTRIQUE NE PAS OUVRIR</p>		
<p>CAUTION: TO REDUCE THE RISK OF ELECTRIC SHOCK DO NOT REMOVE COVER (OR BACK) NO USER-SERVICEABLE PARTS INSIDE REFER SERVICING TO QUALIFIED PERSONNEL</p>		<p>The lightning flash with arrowhead symbol within an equilateral triangle, is intended to alert the user to the presence of uninsulated dangerous voltage within the product's enclosure, that may be of sufficient magnitude to electric shock to persons. Le symbole clair avec point de flèche à l'intérieur d'un triangle équilatéral est utilisé pour alerter l'utilisateur de la présence à l'intérieur du coffret de voltage dangereux non isolé d'ampleur suffisante.</p>	
<p>ATTENTION: POUR EVITER LES RISQUES DE CHOC ELECTRIQUE: NE PAS ENLEVER LE COUVERCLE. AUCUN ENTRETIEN DE PIECES INTERIEURES PAR L'USAGER. CONFIER L'ENTRETIEN AU PERSONNEL QUALIFIE.</p> <p>AVIS: POUR EVITER LES RISQUES D'INCENDIE OU D'ELECTROCUTION, N'EXPOSEZ PAS CET ARTICLE A LA PLUIE OU A L'HUMIDITE.</p>			
			
		<p>exclamation point within an equilateral triangle is intended to alert the user of the presence of important operating and maintenance (servicing) instructions in the literature accompanying the appliance. Le point d'exclamation à l'intérieur d'un triangle équilatéral est employé pour alerter les utilisateurs de la présence d'instructions importantes pour le fonctionnement et l'entretien (service) dans le livret d'instruction accompagnant l'appareil.</p>	

Important Safety Instructions

1. Read these instructions.
2. Keep these instructions.
3. Heed all warnings.
4. Follow all instructions.
5. Do not use this apparatus near water.
6. Clean only with dry cloth.
7. Do not block any ventilation openings. Install in accordance with the manufacturer's instructions.
8. Do not install near any heat sources such as radiators, heat registers, stoves, or other apparatus (including amplifiers) that produce heat.
9. Only use attachments/accessories specified by the manufacturer.

WARNING: To reduce the risk of fire or electric shock, do not expose this unit to rain or moisture

Contents

Introduction	1
What's in the package.....	1
Features	2-7
Cube.....	2
Cube Pro.....	3
Cube G.....	4
Cube Mini.....	5
Cube 4Nano.....	6
Cube DJ.....	7
Front Panel	8-11
Cube.....	8
Cube Pro.....	8
Cube G.....	9
Cube Mini.....	9
Cube 4Nano.....	10
Cube DJ.....	11
Rear Panel	12-15
Cube.....	12
Cube Pro.....	12
Cube G.....	13
Cube Mini.....	14
Cube 4Nano.....	14
Cube DJ.....	15
Mac driver installation	16-17
MAC Software control panel	18
Windows driver installation	19-21
Windows Control Panel	22-25
Hardware Connections	26-29
Cube.....	26
Cube Pro.....	27
Cube G.....	27
Cube Mini.....	28
Cube 4Nano.....	28
Cube DJ.....	29
Minimum System Requirements	29
Specifications	30-35
Cube.....	30
Cube Pro.....	31
Cube G.....	32
Cube Mini.....	33
Cube 4Nano.....	34
Cube DJ.....	35
Services	36

Introduction

Thank you for purchasing the ICON Cube series digital audio Interface. We sincerely trust this product will provide years of satisfactory service, but if anything is not to your complete satisfaction, we will endeavor to make things right.

CUBE Series

In these pages, you'll find a detailed description of the features of the Cube series digital audio interfaces, as well as a guided tour through their front and rear panels, step-by-step instructions for their setup and use, and full specifications.

You'll also find a warranty card enclosed---please don't forget to fill it out and mail it so that you can receive online technical support at: www.icon-global.com. And so we can send you updated information about these and other ICON products in the future. As with most electronic devices, we strongly recommend you retain the original packaging. In the unlikely event the product must be returned for servicing, the original packaging (or reasonable equivalent) is required.

With proper care and adequate air circulation, your Cube series digital audio interface will operate without any trouble for many years. We recommend that you record your serial number in the space provided below for future reference.

Please write your serial number here for future reference:

Purchased at:

Date of purchase:

What's in the package?

- Cube/ Cube Pro/ Cube G / Cube Mini / Cube 4 Nano or Cube DJ USB Recording Interface
- QuickStart Guide
- Driver Software CD / Users' Manual
- USB cable

Features - Cube

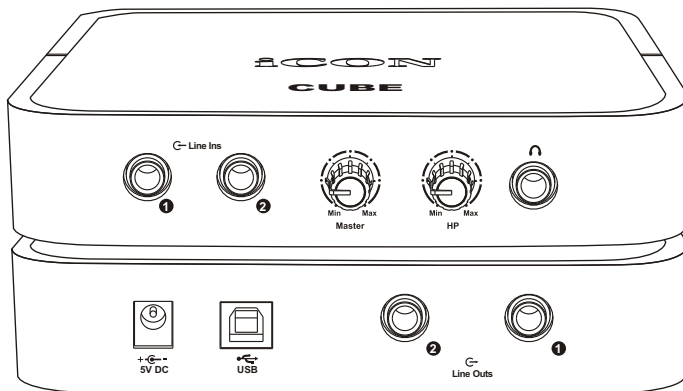

The ICON Cube USB Recording interface provides an audio input and output module with USB connectivity. Main features include:

- 24-Bit 96/192KHz 2-In/2-Out USB Recording Interface
- 2x2 analog line I/O full duplex recording and playback
- 2 analog inputs and 2 analog outputs on 1/4" TRS jacks
- Master volume control on the front panel
- 1 headphone output with assignable source and individual volume control
- USB2.0 High Speed equipped and USB bus-powered
- Supports DirectSound, WDM and ASIO2.0
- Compatible with Mac OS (Intel-Mac) and Windows XP, Vista (32-bit/64-bit) & Windows 7 (32-bit/64-bit)
- Full duplex, simultaneous record/playback
- Rugged aluminum construction

Features - Cube Pro

CUBE Series

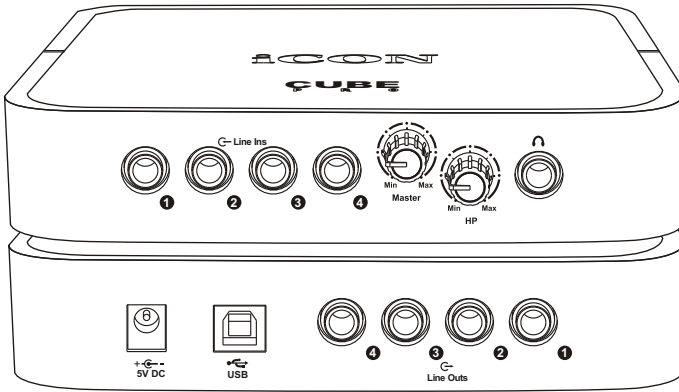

The ICON Cube Pro USB Recording interface provides an audio input and output module with USB connectivity. Main features include:

- 24-Bit 96/192KHz 4-In/4-Out USB Recording Interface
- 4x4 analog line I/O full duplex recording and playback
- 4 analog inputs and 4 analog outputs on 1/4" TRS jacks
- Master volume control on the front panel
- 1 headphone output with assignable source and individual volume control
- Flexible channel routing via the software control panel
- USB2.0 High Speed equipped and USB bus-powered
- Supports DirectSound, WDM and ASIO2.0
- Compatible with Mac OS (Intel-Mac) and Windows XP, Vista (32-bit/64-bit) & Windows 7 (32-bit/64-bit)
- Full duplex, simultaneous record/playback
- Rugged aluminum construction

Features - Cube G

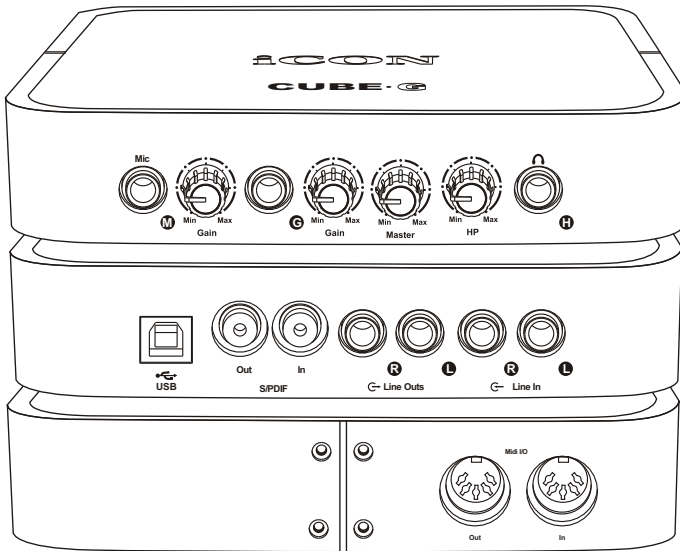

CUBE
Series

The ICON Cube G USB Recording interface provides an audio input and output module with USB connectivity. Main features include:

- 24-Bit 96/192KHz 4-In/4-Out USB Recording Interface
- 2x2 analog I/O full duplex recording and playback
- 1 mic input with individual gain control
- 1 Hi-Z input for guitar or bass with individual gain control
- 2 analog outputs on 1/4" TRS jacks
- Master volume control on the front panel
- 1 headphone output with assignable source and individual volume control
- S/PDIF I/O on RCA coaxial connectors
- 1 x 1 16-channels MIDI I/O
- USB2.0 High Speed equipped and USB bus-powered
- Supports DirectSound, WDM and ASIO2.0
- Compatible with Mac OS (Intel-Mac) and Windows XP, Vista (32-bit/64-bit) & Windows 7 (32-bit/64-bit)
- Full duplex, simultaneous record/playback
- Rugged aluminum construction

Features - Cube Mini

CUBE Series

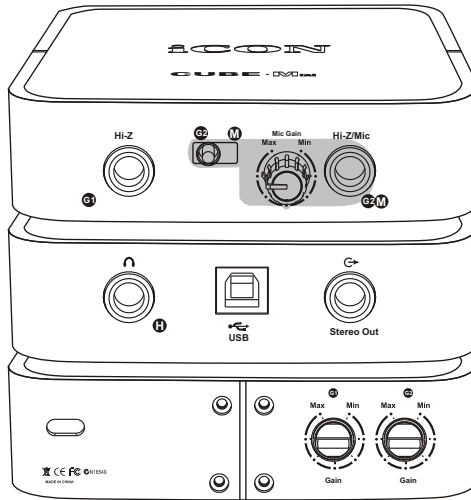

The ICON Cube Mini USB Recording interface provides an audio input and output module with USB connectivity. Main features include:

- Extremely compact size: around 9cm x 9cm
- 24-Bit 96/192KHz 2-In/2-Out USB Recording Interface
- 2x2 analog I/O full duplex recording and playback
- 1 mic input with preamp for dynamic mic, switchable to Hi-Z input for guitar/bass
- 1 Hi-Z input for guitar/bass
- 2 line outputs on a stereo 1/4" TRS jack
- 1 headphone stereo output on 1/4" TRS jack
- USB2.0 High Speed equipped and USB bus-powered
- Supports DirectSound, WDM and ASIO2.0
- Compatible with Mac OS (Intel-Mac) and Windows XP, Vista (32-bit / 64-bit) & Windows 7 (32-bit/64-bit)
- Full duplex, simultaneous record/playback
- Rugged aluminum construction

Features - Cube 4Nano

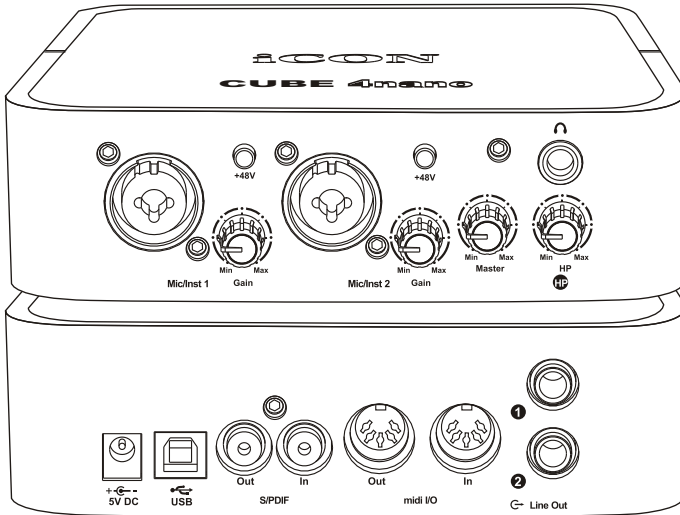

The ICON Cube 4Nano USB Recording interface provides an audio input and output module with USB connectivity. Main features include:

- 24-Bit 96/192KHz 4-In/4-Out USB Recording Interface
- 2x2 analog I/O full duplex recording and playback
- Dual MIC/Instrument preamps with individual gain control and phantom power switch
- 2 analog outputs on 1/4" TRS jacks
- S/PDIF I/O on RCA coaxial connectors
- 1 x 1 – 16 channel MIDI I/O
- Master volume control on the front panel
- 1 headphone output with assignable source and individual volume control
- Flexible channel routing via the software control panel
- USB2.0 High Speed equipped and USB bus-powered
- Supports DirectSound, WDM and ASIO2.0
- Compatible with Mac OS (Intel-Mac) and Windows XP, Vista (32-bit/64-bit) & Windows 7 (32-bit/64-bit)
- Full duplex, simultaneous record/playback
- Rugged aluminum construction

Features - Cube DJ

CUBE Series

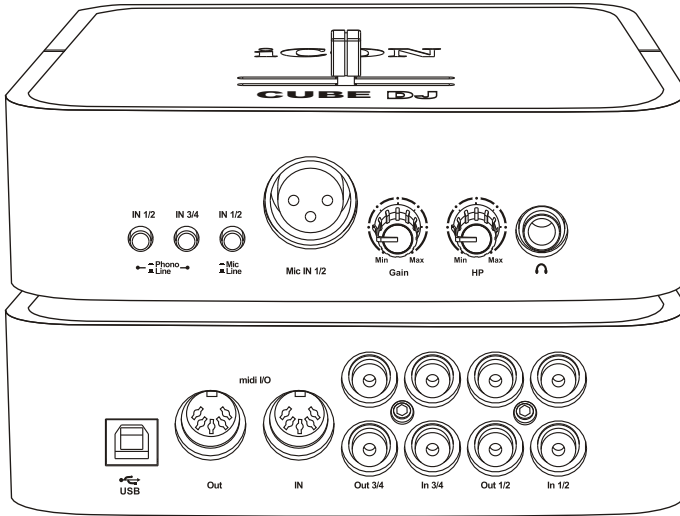

The ICON Cube DJ USB Recording interface provides an audio input and output module with USB connectivity. Main features include:

- 24 Bit 96/192KHz 4-In/4-Out USB Recording Interface for DJ
- 4x4 analog I/O full duplex recording and playback
- 4 analog inputs and 4 analog outputs on RCA jacks
- 1 mic input on XLR connector with gain control
- Individual “Line – Phono” level switch for inputs 1/2 & 3/4
- “Mic In – Line 1/2 In” switch for inputs ½
- Master volume control cross fader allows instant switching between output 1/2 or 3/4.
- 1 headphone output with assignable source and individual volume control
- Flexible channel routing via the software control panel
- USB2.0 High Speed equipped and USB bus-powered
- Supports DirectSound, WDM and ASIO2.0
- Compatible with Mac OS (Intel-Mac) and Windows XP, Vista (32-bit/64-bit) & Windows 7 (32-bit/64-bit)
- Full duplex, simultaneous record/playback
- Rugged aluminum construction

Front Panel - Cube

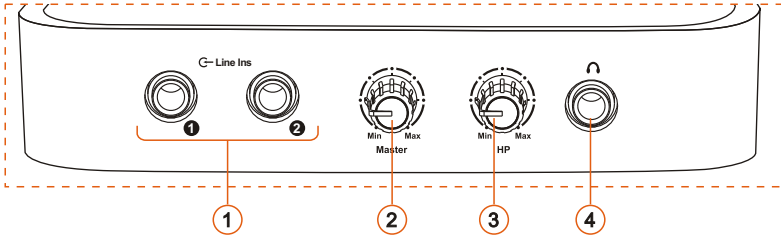

- ① **LINE INPUTS 1-2:**
These are unbalanced analog inputs on standard 1/4" TS connectors at -10dB line level.
- ② **MASTER LEVEL CONTROL:**
This potentiometer controls the master output level of the analog outputs.
- ③ **HEADPHONE LEVEL CONTROL:**
This potentiometer controls the output level of the headphone output.
- ④ **HEADPHONE OUTPUT:**
This output jack accepts a standard 1/4" stereo TRS headphone connector.

Front Panel - Cube Pro

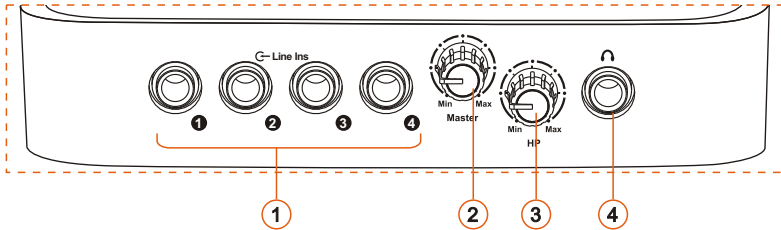

- ① **LINE INPUTS 1-4:**
These are unbalanced analog inputs on standard 1/4" TS connectors at -10dB line level.
- ② **MASTER LEVEL CONTROL:**
This potentiometer controls the master output level of the analog outputs.
- ③ **HEADPHONE LEVEL CONTROL:**
This potentiometer controls the output level of the headphone output.
- ④ **HEADPHONE OUTPUT:**
This output jack accepts a standard 1/4" stereo TRS headphone connector.

Front Panel - Cube G

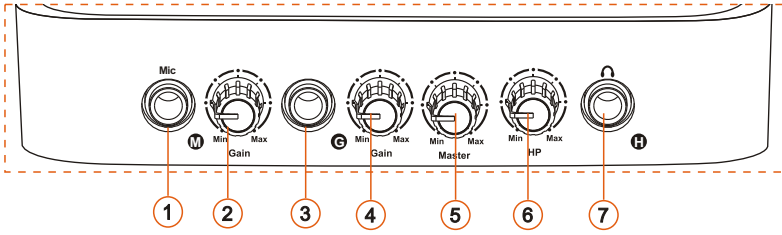

- ① **MIC INPUT:**
This is unbalanced MIC level input.
- ② **INPUT GAIN LEVEL CONTROL**
This potentiometer controls the input level of its associated analog mic input.
- ③ **HI-ZI INPUT:**
This is hi-impedance input for guitar.
- ④ **INPUT GAIN LEVEL CONTROL**
This potentiometer controls the input level of its associated guitar input.
- ⑤ **MASTER LEVEL CONTROL:**
This potentiometer controls the master output level of the analog outputs.
- ⑥ **HEADPHONE LEVEL CONTROL:**
This potentiometer controls the output level of the headphone output.
- ⑦ **HEADPHONE OUTPUT:**
This output jack accepts a standard 1/4" stereo TRS headphone connector.

Front Panel - Cube Mini

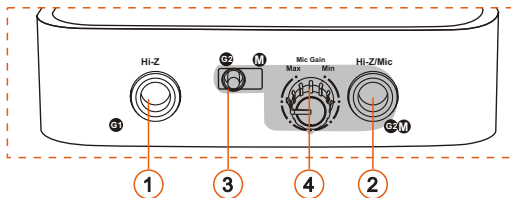

- ① **HI-ZI INPUT:**
This is hi-impedance input for guitar.
- ② **HI-Zi / MIC INPUT:**
This connector accept mic or guitar input.
- ③ **HI-Zi / MIC INPUT SWITCH:**
MIC or HI-ZI input switch for input 2.
- ④ **INPUT GAIN LEVEL CONTROL FOR MIC**
This potentiometer controls the input level of its associated mic input.

Front Panel - Cube 4Nano

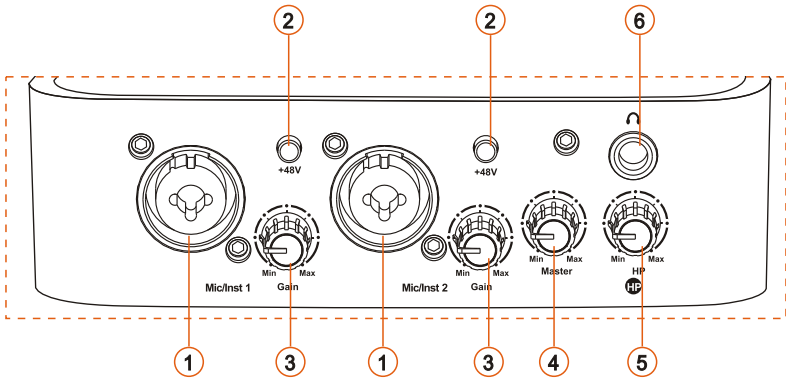

① "MIC/INST" INPUTS 1/2

Unbalanced instrument and mic level inputs. These hybrid connectors will accept a standard 3-pin XLR plug or a 1/4" TS connector.

② 48V PHANTOM POWER SWITCH

Press to supply +48V phantom power to the associated XLR input. This phantom power circuit is suitable for most condenser microphones.

③ INPUT GAIN LEVEL CONTROLS 1/2

These potentiometers control the input level of their associated analog Mic/Inst/Line input.

④ MASTER LEVEL CONTROL

This potentiometer controls the master output level of the analog outputs.

⑤ HEADPHONE LEVEL CONTROL

This potentiometer controls the output level of the headphone output.

⑥ HEADPHONE OUTPUT

This output jack accepts a standard 1/4" stereo TRS headphone connector.

Front Panel - Cube DJ

CUBE Series

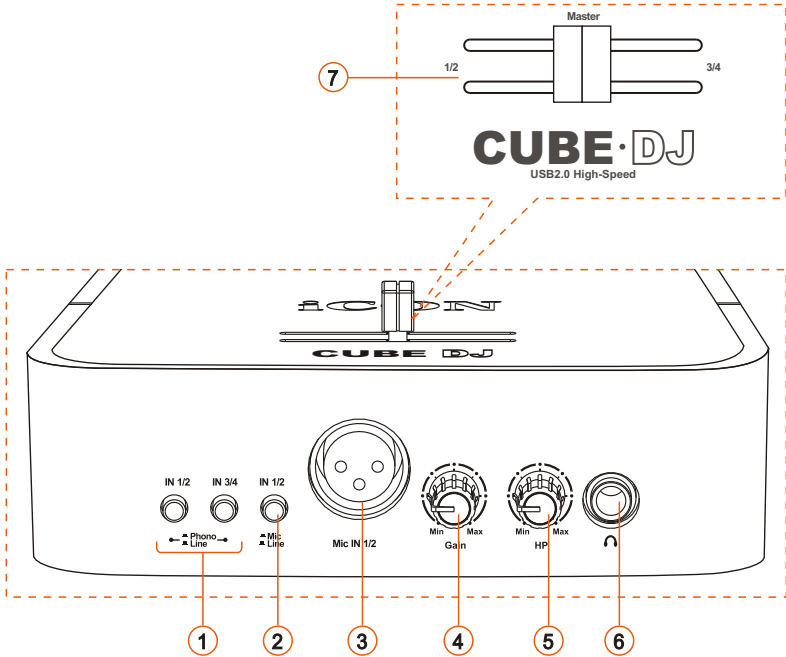

- ① **“LINE/PHONO” SWITCH FOR INPUTS 1/2 & 3/4**
Switch to adjust the input level of inputs 1/2 & 3/4 for different input devices.
- ② **“MIC/LINE” SWITCH FOR INPUTS 1/2**
Activate the button if the mic is used for inputs 1/2 otherwise use the line input connectors (RCA) located on the rear panel.
- ③ **MIC INPUT CONNECTOR FOR INPUTS 1/2**
This is unbalanced MIC level input for a dynamic microphone.
- ④ **MIC INPUT GAIN LEVEL CONTROL**
This potentiometer controls the input level of the mic.
- ⑤ **HEADPHONE LEVEL CONTROL**
This potentiometer controls the output level of the headphone output.
- ⑥ **HEADPHONE OUTPUT**
This output jack accepts a standard 1/4” stereo TRS headphone connector.
- ⑦ **MASTER VOLUME CONTROL CROSS FADER**
Horizontal cross fader “Master volume control” allows instant monitoring between output 1/2 or 3/4.

Rear Panel - Cube

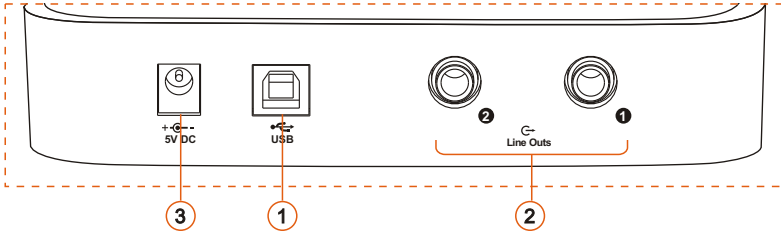

- ① **USB 2.0 CONNECTOR:**
Connect it with the provided USB cable to your computer's USB connector. Your computer must have a USB2.0 connector to maximize the performance of Cube.
- ② **LINE OUTPUTS 1-2:**
These are unbalanced analog outputs on standard 1/4" TS connectors at +6dBu line level.
- ③ **POWER SUPPLY CONNECTOR:**
Connect the 5VDC power supply to this jack using ICON AC adaptor in case your notebook is not capable to supply sufficient power to Cube.

Note: Normally, external power supply is not needed, Cube series audio interface is USB-bus powered.

Rear Panel - Cube Pro

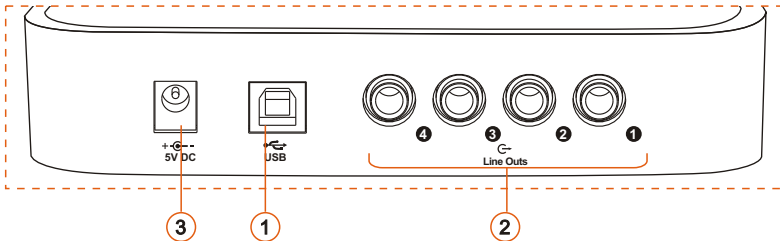

- ① **USB 2.0 CONNECTOR:**
Connect it with the provided USB cable to your computer's USB connector. Your computer must have a USB2.0 connector to maximize the performance of Cube Pro.
- ② **LINE OUTPUTS 1-4:**
These are unbalanced analog outputs on standard 1/4" TS connectors at +6dBu line level.
- ③ **POWER SUPPLY CONNECTOR:**
Connect the 5VDC power supply to this jack using ICON AC adaptor in case your notebook is not capable to supply sufficient power to Cube Pro.

Note: Normally, external power supply is not needed, Cube series audio interface is USB-bus powered.

Rear / Side Panel - Cube G

CUBE Series

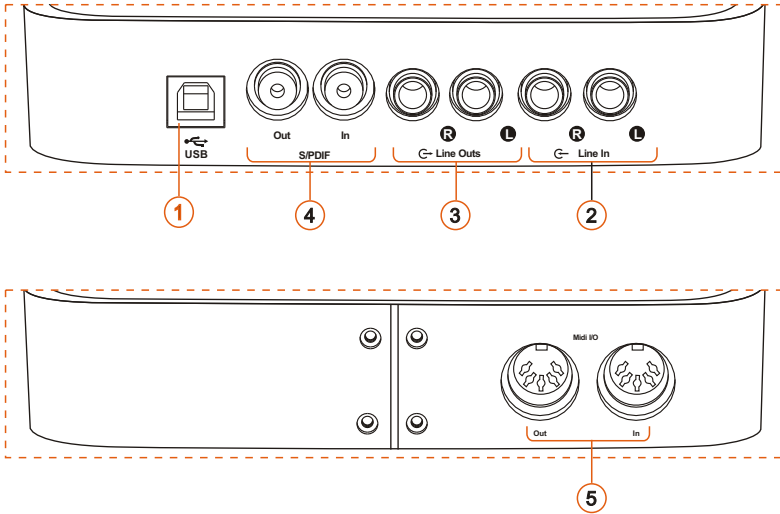

① USB 2.0 CONNECTOR

Connect it with the provided USB cable to your Mac/PC's USB connector. Your Mac/PC must have a USB2.0 connector in order to run the full speed of Cube G.

② LINE INPUTS 1/2

These are unbalanced analog inputs on standard 1/4" TS connectors at -10dB line level.

③ LINE OUTPUTS 1/2

These are unbalanced analog outputs on standard 1/4" TS connectors at +6dBu line level.

④ S/PDIF COAXIAL I/O CONNECTORS

S/PDIF digital input and output on coaxial RCA connectors. The digital input is selected via the Cube G's software control panel, while the digital output will be sent to the coaxial.

⑤ MIDI I/O CONNECTORS

MIDI input and output on standard 5-pin DIN connectors

Rear / Side Panel - Cube Mini

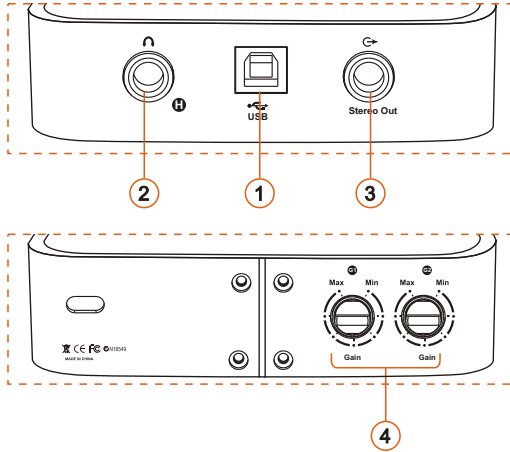

- ① **USB 2.0 CONNECTOR:**
Connect it with the provided USB cable to your computer's USB connector. Your computer must have a USB2.0 connector to maximize the performance of Cube Mini.
- ② **HEADPHONE OUTPUT:**
This output jack accepts a standard 1/4" stereo TRS headphone connector.
- ③ **STEREO OUTPUT:**
These are unbalanced stereo output on standard 1/4" TS connectors at +6dBu line level.
- ④ **INPUT GAIN LEVEL CONTROL FOR HI-Z INPUTS 1 & 2:**
These potentiometer control the input level of their associated guitar input 1 & 2.

Rear Panel - Cube 4Nano

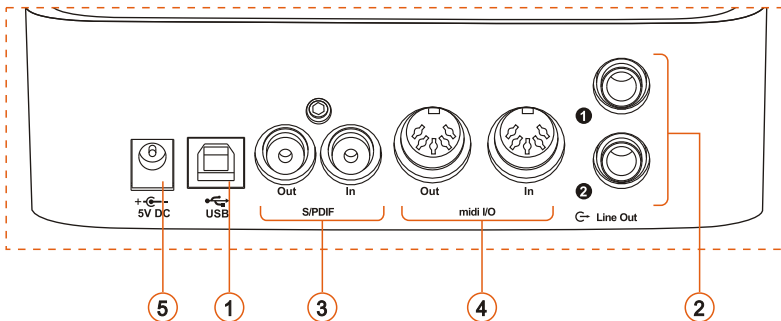

- ① **USB 2.0 CONNECTOR**
Connect it with the provided USB cable to your Mac/PC's USB connector. Your Mac/PC must have a USB2.0 connector in order to run the full speed of Cube 4 Nano.
- ② **LINE OUTPUTS 1/2**
These are unbalanced analog outputs on standard 1/4" TS connectors at +6dBu line level.
- ③ **S/PDIF COAXIAL I/O CONNECTORS**
S/PDIF digital input and output on coaxial RCA connectors. The digital input is selected via the Cube 4 Nano's software control panel, while the digital output will be sent to the coaxial.
- ④ **MIDI I/O CONNECTORS**
MIDI input and output on standard 5-pin DIN connectors
- ⑤ **POWER SUPPLY CONNECTOR**
Cube 4 Nano is USB-bus powered. If your computer does not supply sufficient power, connect a ICON 5VDC power supply adapter to this jack. *(Note: You can get the power adapter from ICON distributors/dealers near you)*

Rear Panel - Cube DJ

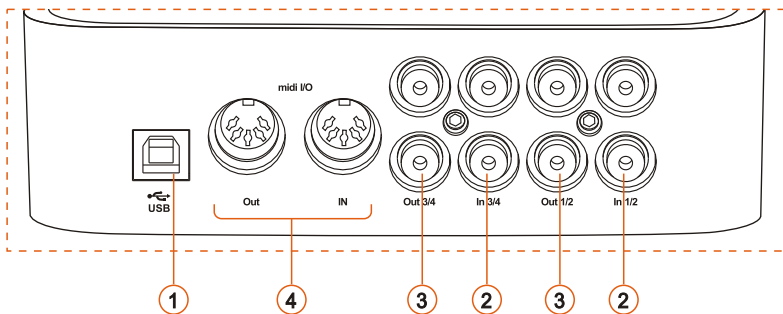

- ① **USB 2.0 CONNECTOR**
Connect it with the provided USB cable to your Mac/PC's USB connector. Your Mac/PC must have a USB2.0 connector in order to run the full speed of Cube DJ.
- ② **LINE INPUTS 1/2 & 3/4**
These are unbalanced analog inputs on RCA connectors at -10dB line level.
- ③ **LINE OUTPUTS 1/2 & 3/4**
These are unbalanced analog outputs on RCA connectors at +6dBu line level.
- ④ **MIDI I/O CONNECTORS**
MIDI input and output on standard 5-pin DIN connectors

Mac driver installation

Please follow the step-by-step procedures below to install your Cube series USB recording interface and its driver.

① **Turn on your Mac**

Note: Do not connect the Cube series digital audio interface to your Mac yet

② **Insert the provided driver CD into your CD-Rom.**

After you have inserted the provided Driver CD into your CD-Rom, a pop-up window should appear as shown in Diagram 1, then click on the "Mac" folder to open the installation files list. Click "ICON_Cube.mpkg"

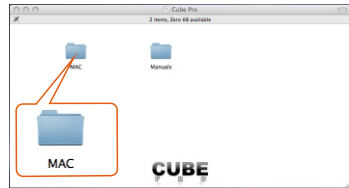

Diagram 1

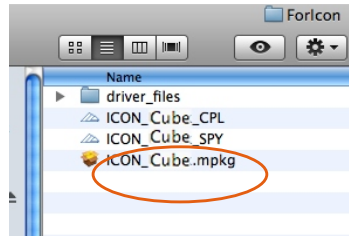

Diagram 2

③ **Welcome Screen appears**

Choose "Continue" when you see the Welcome Screen shown in Diagram 3



Diagram 3

④ **Set install location**

Click the "Change install location" button if you would like to set your preferred install location, otherwise click the "Install" button.

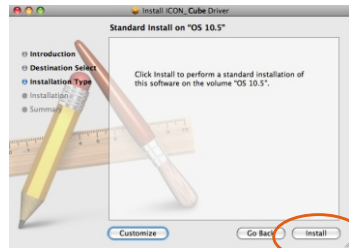

Diagram 4

⑤ **Installation start**

The driver installation has started, please wait until the process has completed.

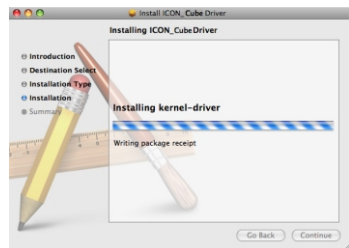

Diagram 5

Mac driver installation

- ⑥ **Installation completed**
The driver installation has completed successfully. Click the “Close” button.

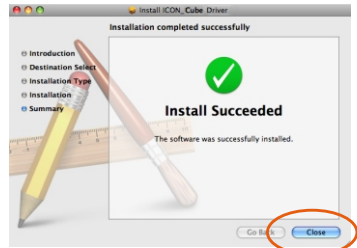

Diagram 6

- ⑦ **Copy the software control panel shortcut logo to your desktop**
Open the previous “Mac” folder. Copy the 'Cube’ software panel shortcut logo and paste it to your desktop.

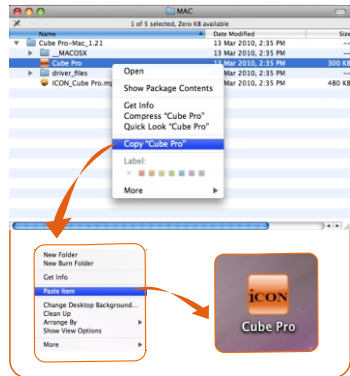

Diagram 7

- ⑧ **Launch the software control panel**
Click the Cube's software control panel shortcut logo you have just copied to your desktop to launch the software control panel.

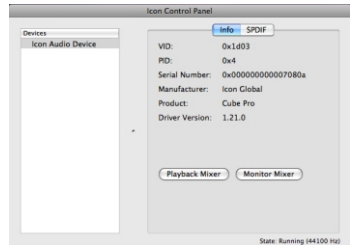

Diagram 8

- ⑨ **Audio MIDI setup**
Open the “Audio MIDI setup” window and check if the Cube device has setup properly as shown below in diagram 9. If your Cube device does not appear on the system settings, it means the driver did not install properly, go through the “Driver Installation” procedure again.

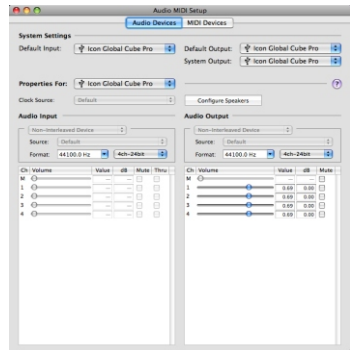

Diagram 9

Software control panel

The “Playback” and “Monitor” mixers work like a matrix mixer. Activate and adjust the correspondence input or output channel level. They are very useful and make your inputs and outputs very flexible. You may route any of your input(s) to any output(s).

Playback Mixer

Software outputs level metering

Cube – Ch 1,2 output level metering

Cube Pro – Ch 1,2 & Ch 3,4 output level metering

Cube G – Ch 1,2 & S/PDIF output level metering

Cube Mini – Ch 1,2 output level metering

Cube 4 Nano – Ch 1,2 & S/PDIF output level metering

Cube DJ – Ch 1,2 & Ch 3,4 output level metering

Showing the input level for the software input channel.

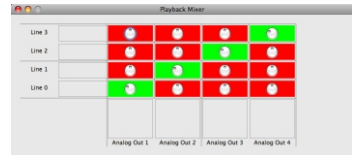

Playback Mixer

Hardware outputs level metering

Cube – Ch 1,2 output level metering

Cube Pro – Ch 1,2 & Ch 3,4 output level metering

Cube G – Ch 1,2 & S/PDIF output level metering

Cube Mini – Ch 1,2 output level metering

Cube 4 Nano – Ch 1,2 & S/PDIF output level metering

Cube DJ – Ch 1,2 & S/PDIF output level metering

Showing the output level for the hardware output channel.

Monitor Mixer

Hardware inputs level metering

Cube – Ch 1,2 input level metering

Cube Pro – Ch 1,2 & Ch 3,4 input level metering

Cube G – Ch 1,2 & S/PDIF input level metering

Cube Mini – Ch 1,2 input level metering

Cube 4 Nano – Ch 1,2 & S/PDIF input level metering

Cube DJ – Ch 1,2 & Ch 3,4 input level metering

Showing the input level for the hardware input channel.



Monitor Mixer

Hardware outputs level metering

Cube – Ch 1,2 output level metering

Cube Pro – Ch 1,2 & Ch 3,4 output level metering

Cube G – Ch 1,2 & S/PDIF output level metering

Cube Mini – Ch 1,2 output level metering

Cube 4 Nano – Ch 1,2 & S/PDIF output level metering

Cube DJ – Ch 1,2 & S/PDIF output level metering

Showing the output level for the hardware output channel.

Windows driver installation

Please follow the step-by-step procedures below to install your Cube series USB recording interface and its driver.

1 Turn on your computer

Note: Do not connect the Cube series digital audio interface to your computer yet

2 Insert the Driver CD into your CD-Rom.

After you have inserted the provided Driver CD into your CD-Rom, an Installation screen should appear as shown in Diagram 1, then click "Windows Driver" for the driver installation"

Note: If the Installation screen do not appear automatically. Go to the CD folder and double click "Setup"



Diagram 1

3 Installation Wizard appear

Choose "Next" when you see the Welcome Screen as Diagram 2 shown



Diagram 2

4 License Agreement

Check mark the "I accept the terms in the License Agreement" and click "Next".

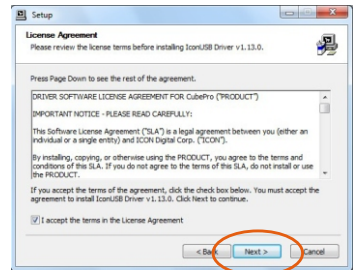

Diagram 3

5 Confirm driver installation

A confirmation on the driver installation screen will appear, click "Next".

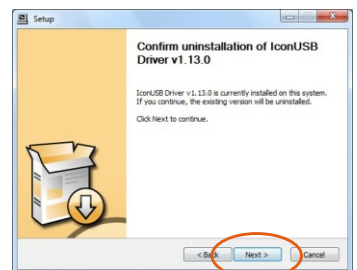

Diagram 4

Windows driver installation

6 Driver setup

Choose the location of the driver and click "Next" as shown in Diagram 5

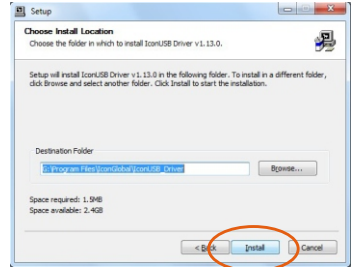

Diagram 5

7 Installation start

The installation process has started, the process may take some time depending on your computer performance, please be patient and wait for the process to finish.

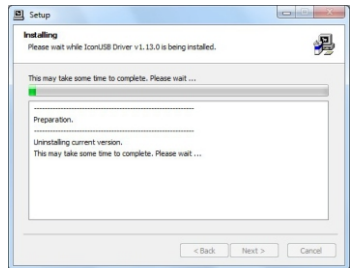

Diagram 6

8 Software installation window

A window as shown in Diagram 7 should appear. Choose "Install this driver software anyway"

Note: Although this message appears, the Cube series driver is fully tested and supports Windows XP, Vista & Windows 7

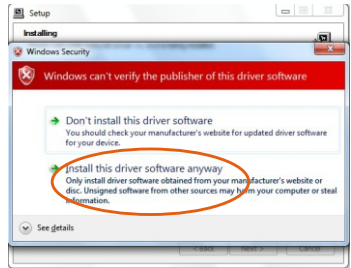

Diagram 7

9 Setup completed

A window as shown in Diagram 8 should appear. Choose "Next".

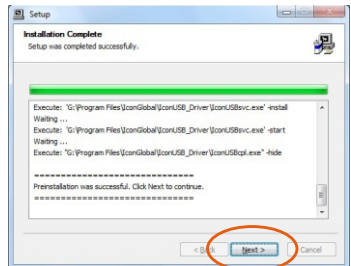

Diagram 8

Windows driver installation

10 Connect your Cube series digital audio interface

Now connect the Cube series digital audio interface to your computer's USB port and click "Finish".

Note: Cube series audio interfaces only support USB 2.0. Your computer must have an USB2.0 port.



Diagram 9

11 Installing device driver software

The Cube driver is installing



Diagram 10

12 Driver installation completed

Cube/CubePro/CubeG/Cube Mini/Cube 4 Nano/Cube DJ driver installation has completed and is ready to use.

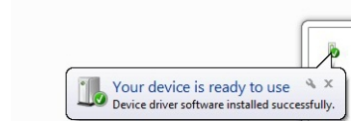

Diagram 11

13 Launch the software control panel

You may click the Cube logo on the system tray to launch the software control panel (Page 22).



Diagram 12

Note: For the latest driver updates please check www.icon-global.com

Windows Control Panel

Sample rate settings

Select your desired sampling rate from 44.1KHz to 192KHz on the pull down window shown in Diagram 1. Click "Apply" after the selection has been made to set the value.

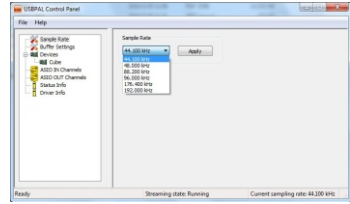

Diagram 1

Buffer Size settings

You may select the buffer size for "Streaming" and "ASIO". Click "Apply" when you have made the selections. *(Note: If a clicking sound occurs, you should change to a larger buffer size for the settings. If the largest buffer size has been selected and there is still a clicking sound. It means your computer performance is not able to handle the task. (It is not caused by the Cube series digital audio interface))*

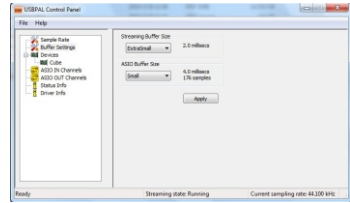

Diagram 2

Device settings

Shows the serial number & product ID of your Cube/Cube Pro/Cube G/Cube Mini/Cube 4 Nano or Cube DJ device. If it doesn't show, it means your device is not properly installed. Please go through the "Driver Installation" process again (Page 19).

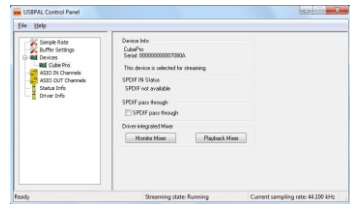

Diagram 3

Monitor Mixer

Click this button to launch the "Monitor Mixer" (Page 23)

Playback Mixer

Click this button to launch the "Playback Mixer" (Page 24)

S/PDIF Status and Pass Through (Cube G/Cube 4 Nano only)

Showing the S/PDIF device signal status.

S/PDIF Pass Through (Cube G/Cube 4 Nano only)

"Tick" the box if you want S/PDIF signal pass through

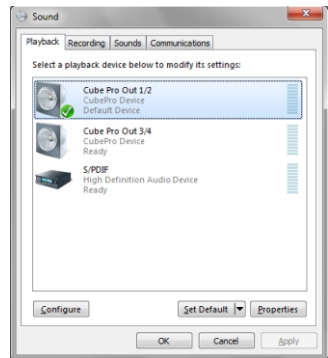
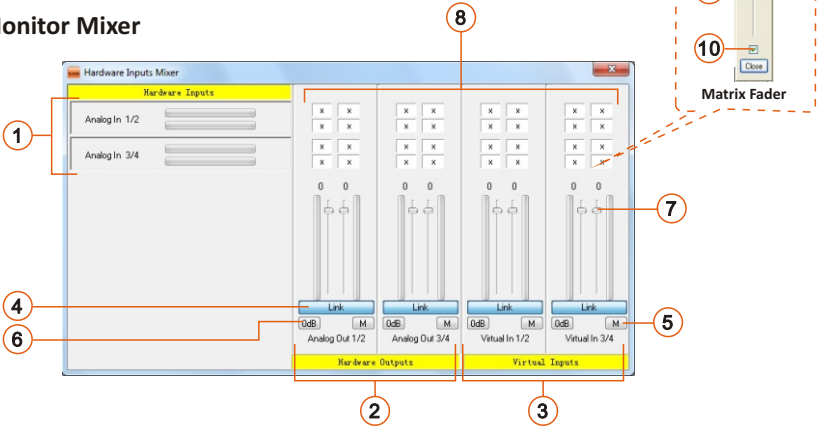

Diagram 4

Windows Control Panel (Continues)

Monitor Mixer



- ① **Hardware inputs level metering**
Cube – Ch 1,2 input level metering
Cube Pro – Ch 1,2 & Ch 3,4 input level metering
Cube G – Ch 1,2 & S/PDIF input level metering
Cube Mini – Ch 1,2 input level metering
Cube 4 Nano – Ch 1,2 & S/PDIF input level metering
Cube DJ – Ch 1,2 & Ch 3,4 input level metering
 Showing the input level for the hardware input channel.
- ② **Hardware outputs level metering**
Cube – Ch 1,2 output level metering
Cube Pro – Ch 1,2 & Ch 3,4 output level metering
Cube G – Ch 1,2 & S/PDIF output level metering
Cube Mini – Ch 1,2 output level metering
Cube 4 Nano – Ch 1,2 & S/PDIF output level metering
Cube DJ – Ch 1,2 & S/PDIF output level metering
 Showing the output level for the hardware output channel.
- ③ **Virtual inputs level metering**
Cube - Virtual1,2 input level metering
Cube Pro - Virtual1,2 & Virtual3,4 input level metering
Cube G - Virtual1,2 input level metering
Cube Mini - Virtual1,2 input level metering
Cube 4 Nano - Virtual1,2 input level metering
Cube DJ - Virtual1,2 & Virtual3,4 input level metering
 Showing the input level for the virtual input channel.
- ④ **Link switch**
 Switch to adjust both channels level simultaneously.
- ⑤ **Mute switch**
 Switch to mute the corresponding channel.
- ⑥ **“0dB” switch**
 Switch to instantly adjust the corresponding channel to “0dB” level.

- 7 **Gain control fader**
Slide to adjust the gain level for the corresponding channel.
- 8 **Inputs & Outputs Matrix switches**
Switch to turn On/Off the corresponding hardware input channel route to the corresponding hardware output channel. The matrix is very useful and makes your inputs and outputs very flexible. You may route any of your input(s) to any output(s).
- 9 **Inputs & Outputs Matrix Mixer**
"Tick" the box to activate the mixer.
- 10 **Inputs & Outputs Matrix Mixer Gain Control**
Adjust the gain for the corresponding hardware channel. After finishing the adjustment, click "Close" to close the window.

Playback Mixer

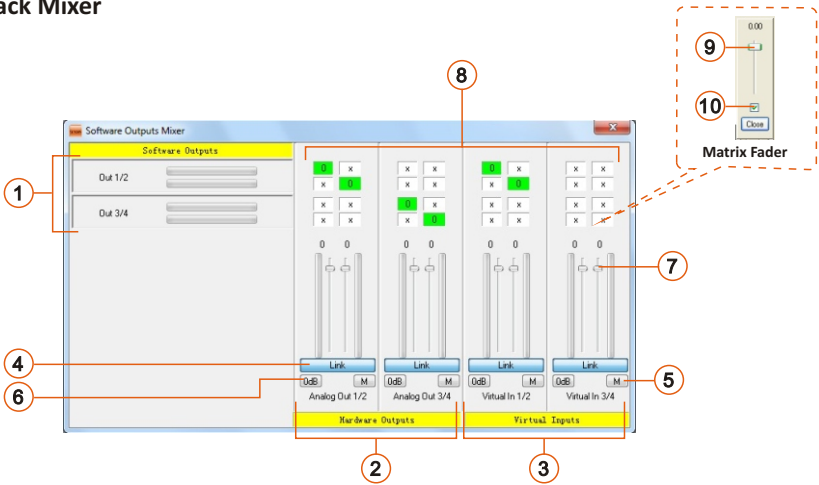

- 1 **Software outputs level metering**
 - Cube – Ch 1,2 output level metering
 - Cube Pro – Ch 1,2 & Ch 3,4 output level metering
 - Cube G – Ch 1,2 & S/PDIF output level metering
 - Cube Mini – Ch 1,2 output level metering
 - Cube 4 Nano – Ch 1,2 & S/PDIF output level metering
 - Cube DJ – Ch 1,2 & Ch 3,4 output level metering
 Showing the input level for the software input channel.
- 2 **Hardware outputs level metering**
 - Cube – Ch 1,2 output level metering
 - Cube Pro – Ch 1,2 & Ch 3,4 output level metering
 - Cube G – Ch 1,2 & S/PDIF output level metering
 - Cube Mini – Ch 1,2 output level metering
 - Cube 4 Nano – Ch 1,2 & S/PDIF output level metering
 - Cube DJ – Ch 1,2 & S/PDIF output level metering
 Showing the output level for the hardware output channel.

- ③ **Virtual inputs level metering**
Cube - Virtual1,2 input level metering
Cube Pro - Virtual1,2 & Virtual3,4 input level metering
Cube G - Virtual1,2 input level metering
Cube Mini - Virtual1,2 input level metering
Cube 4 Nano - Virtual1,2 input level metering
Cube DJ - Virtual1,2 & Virtual3,4 input level metering
Showing the input level for the virtual input channel.
- ④ **Link switch**
Switch to adjust both channels level simultaneously.
- ⑤ **Mute switch**
Switch to mute the corresponding channel.
- ⑥ **"0dB" switch**
Switch to instantly adjust the corresponding channel to "0dB" level.
- ⑦ **Gain control fader**
Slide to adjust the gain level for the corresponding channel.
- ⑧ **Inputs & Outputs Matrix switches**
Switch to turn On/Off the corresponding hardware input channel route to the corresponding hardware output channel. The matrix is very useful and makes your inputs and outputs very flexible. You may route any of your input(s) to any output(s).
- ⑨ **Inputs & Outputs Matrix Mixer**
"Tick" the box to activate the mixer.
- ⑩ **Inputs & Outputs Matrix Mixer Gain Control**
Adjust the gain for the corresponding hardware channel.
After finishing the adjustment, click "Close" to close the window.

Hardware Connections

Connect the Cube series digital audio interface outputs to your amplifier, powered monitors or surround system. Two-channel stereo operation, the default outputs are channels 1 and 2.

If you are monitoring through headphones, connect your headphones to the device's headphone output.

Connect your microphones, instruments or other line level analog sources to the device's analog inputs. *(Note: Cube and Cube Pro only accept line level inputs)*

Connect your S/PDIF digital devices to the coaxial digital I/O and MIDI device to the MIDI I/O.
(For Cube G / Cube 4 Nano only)

Cube Connections

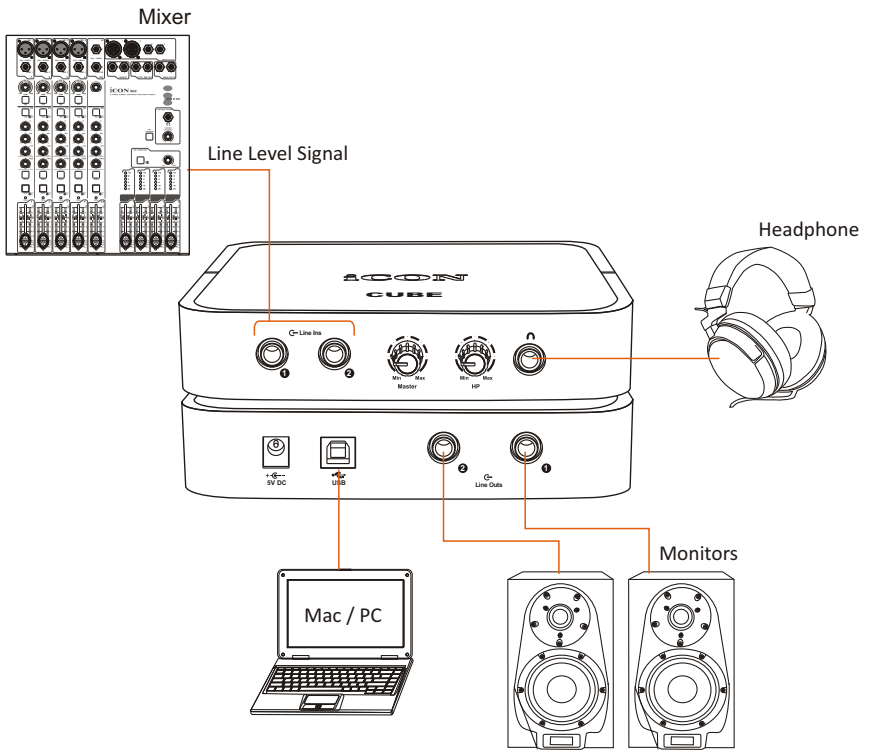

Hardware Connections (Continues)

CUBE Series

Cube Pro Connections

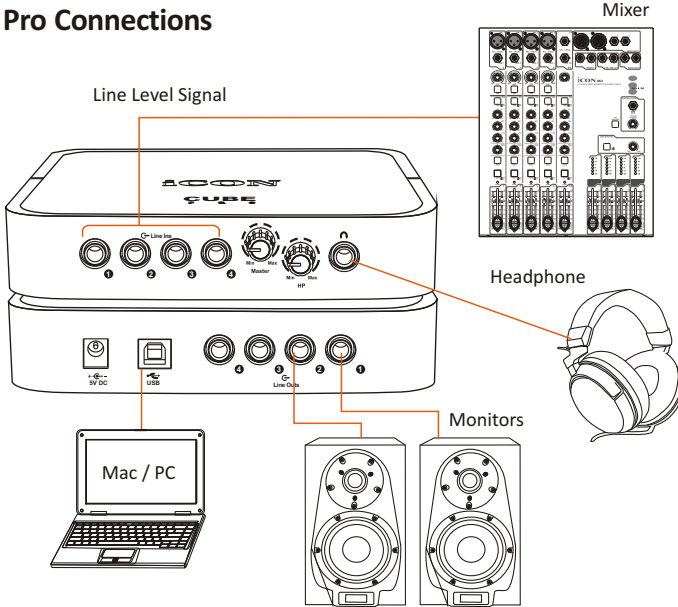

Cube G Connections

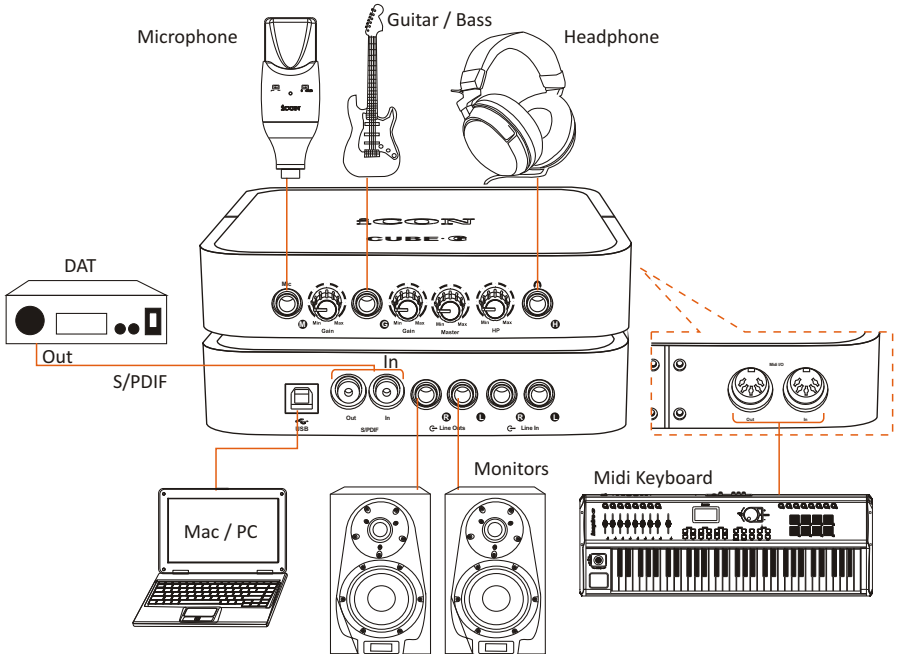

Hardware Connections (Continues)

Cube Mini Connections

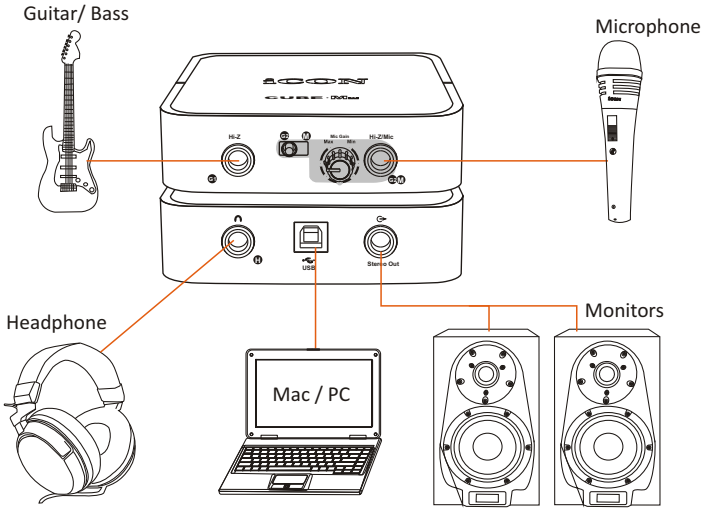

CUBE Series

Cube 4Nano Connections

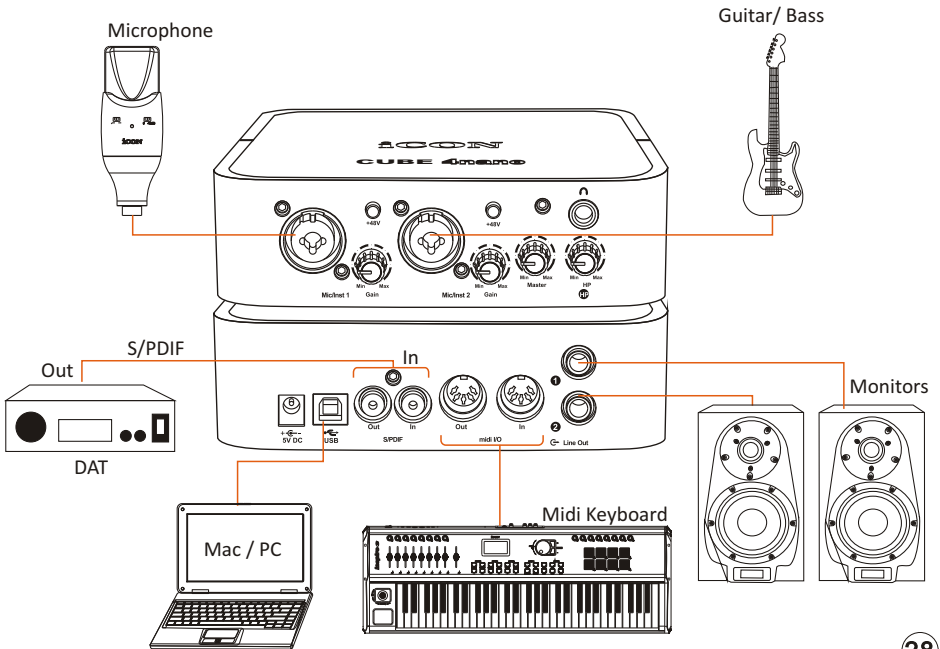

Hardware Connections *(Continues)*

Cube DJ Connections

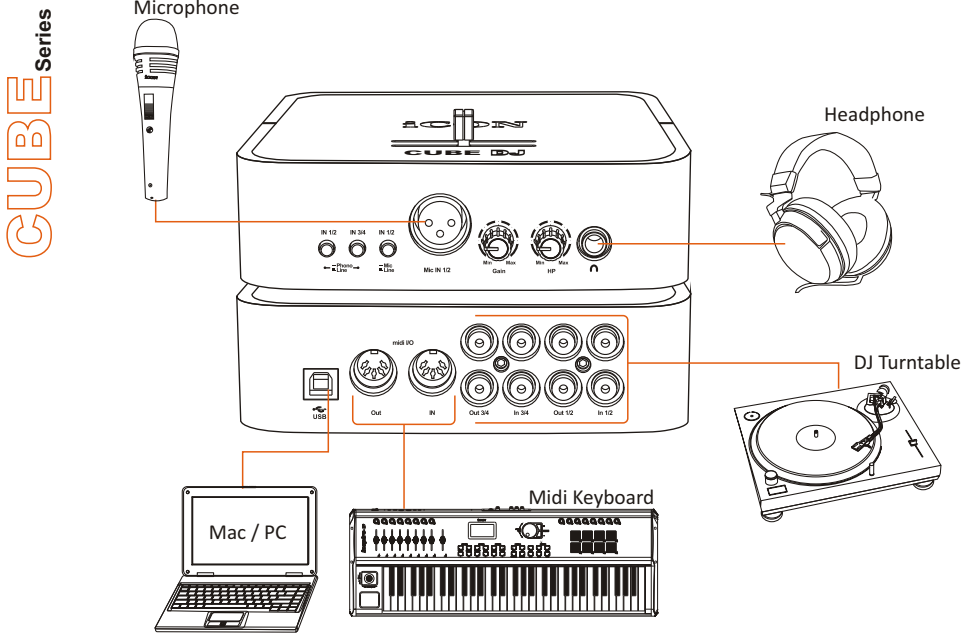

Minimum System Requirements

Important: The Cube series digital audio interface is supported by Mac OS (Intel-Mac), Windows XP, Windows Vista and Windows 7 (32-bit/64-bit). The Cube series digital audio interface is not supported by Windows 98 or Windows Me. For Windows XP, you must be running SP1 or later. Visit the Windows update web pages to make sure you have the most current updates and fixes supplied by Microsoft. On the Mac, the Cube series digital audio interface is supported by Mac OSX version 10.5.5 or later (must be Intel-Mac). Earlier versions of Mac operating systems are not supported.

Windows OP:

Pentium 4 -1.0GHz or higher
1.0Ghz RAM
DirectX 8.1 or higher
Windows XP (SP1), Windows 2000 (SP3),
Windows Vista or Windows 7

Mac OP:

Intel-Mac 1.0GHz or higher
1.0GHz RAM
OS 10.5.5 or later

Specifications *(Measured at 48KHz Sample Rate)*

Cube

Line Inputs 1/2(Unbanced):

Frequency Response:..... 22Hz to 22kHz (+/-0.1dB)
Dynamic Range:100dB, A-weighted
Signal-to-Noise Ratio:-100dB, A-weighted
THD+N:<0.0061% (-90dB)
Crosstalk:-100dB @ 1kHz
Nominal Input Level:Unbalanced: +4dBV, typical;
Maximum Input level:Unbalanced: +11dBV, typical;
Input Impedance:10K Ohms, typical

Line Outputs 1/2 (Unbanced):

Frequency Response:22Hz 22kHz (+/-0.1dB)
Dynamic Range:102dB, A-weighted
Signal-to-Noise Ratio:-102dB, A-weighted
THD+N:<0.003% (-90 dB)
Crosstalk:-100dB @ 1kHz
Nominal Output Level:Unbalanced: +4dBV, typical;
Maximum Output Level:+11dBV, typical;
Output Impedance:150 Ohm
Load Impedance:600 Ohm minimum

Headphone Outputs: 1 & 2 (at Maximum Volume; Into 100 Ohm load):

Frequency Response:22Hz to 22kHz (+/-1dB)
Power into Ohms:90 mW into 100 Ohms
THD+N:<0.06% (-66dB)
Signal-to-Noise Ratio:-90dB, A-weighted
Max Output Level into 100 Ohms:+2.0dBV, typical
Output Impedance:75 Ohm
Load Impedance:32 to 600 Ohms

Specifications *(Measured at 48KHz Sample Rate)(Continues)*

CUBE Series

Cube Pro

Line Inputs 1/4(Unbanced):

Frequency Response:.....22Hz to 22kHz (+/-0.1dB)
Dynamic Range:100dB, A-weighted
Signal-to-Noise Ratio:-100dB, A-weighted
THD+N:<0.0061% (-90dB)
Crosstalk:-100dB @ 1kHz
Nominal Input Level:Unbalanced: +4dBV, typical;
Maximum Input level:Unbalanced: +11dBV, typical;
Input Impedance:10K Ohms, typical

Line Outputs 1/4 (Unbanced):

Frequency Response:22Hz 22kHz (+/-0.1dB)
Dynamic Range:102dB, A-weighted
Signal-to-Noise Ratio:-102dB, A-weighted
THD+N:<0.003% (-90 dB)
Crosstalk:-100dB @ 1kHz
Nominal Output Level:Unbalanced: +4dBV, typical;
Maximum Output Level:+11dBV, typical;
Output Impedance:150 Ohm
Load Impedance:600 Ohm minimum

Headphone Outputs: 1 & 2 (at Maximum Volume; Into 100 Ohm load):

Frequency Response:22Hz to 22kHz (+/-1dB)
Power into Ohms:90 mW into 100 Ohms
THD+N:<0.06% (-66dB)
Signal-to-Noise Ratio:-90dB, A-weighted
Max Output Level into 100 Ohms:+2.0dBV, typical
Output Impedance:75 Ohm
Load Impedance:32 to 600 Ohms

Specifications *(Measured at 48KHz Sample Rate)(Continues)*

Cube Mini

CUBE Series

Inst1/2 & Mic2 Inputs:

Frequency Response:22Hz to 22kHz (+/-0.1dB)
Dynamic Range:100dB, A-weighted
Signal-to-Noise Ratio:-100dB, A-weighted
THD+N:<0.0061% (-90dB)
Crosstalk:-100dB @ 1kHz
Input Impedance:Inst in: 500K Ohms, typical;
Mic in: 1.8K Ohms, typical
Total Gain Range:+45dB

Line Outputs 1/2 (Stereo, Unbanced):

Frequency Response:22Hz 22kHz (+/-0.1dB)
Dynamic Range:102dB, A-weighted
Signal-to-Noise Ratio:-102dB, A-weighted
THD+N:<0.003% (-90 dB)
Crosstalk:-100dB @ 1kHz
Nominal Output Level:Unbalanced: +4dBV, typical;
Maximum Output Level:+11dBV, typical;
Output Impedance:150 Ohm
Load Impedance:600 Ohm minimum

Headphone Outputs: 1 & 2 (at Maximum Volume; Into 100 Ohm load):

Frequency Response:22Hz to 22kHz (+/-1dB)
Power into Ohms:90 mW into 100 Ohms
THD+N:<0.06% (-66dB)
Signal-to-Noise Ratio:-90dB, A-weighted
Max Output Level into 100 Ohms:+2.0dBV, typical
Output Impedance:75 Ohm
Load Impedance:32 to 600 Ohms

Specifications *(Continues)*

Cube 4Nano

Mic1 / 2 Inputs (at Minimum Gain):

- Frequency Response:22Hz to 22kHz (+/-0.1dB)
- Dynamic Range:100dB, A-weighted
- Signal-to-Noise Ratio:-100dB, A-weighted
- THD+N:<0.0061% (-90dB)
- Crosstalk:-87dB @ 1kHz
- Input Impedance:Mic in: 1.8K Ohms, typical
- Adjustable Gain:+34dB
- Total Gain Range:+50dB

Inst1 / 2 Inputs (at Minimum Gain):

- Frequency Response:22Hz to 22kHz (+/-0.1dB)
- Dynamic Range:100dB, A-weighted
- Signal-to-Noise Ratio:-100dB, A-weighted
- THD+N:<0.0061% (-90dB)
- Crosstalk:-87dB @ 1kHz
- Input Impedance:Inst in: 500K Ohms, typical;
- Adjustable Gain:+39dB
- Total Gain Range:+39dB

Line Outputs 1/2 (Unbanced):

- Frequency Response:22Hz 22kHz (+/-0.1dB)
- Dynamic Range:102dB, A-weighted
- Signal-to-Noise Ratio:-102dB, A-weighted
- THD+N:<0.003% (-90 dB)
- Crosstalk:-87dB @ 1kHz
- Nominal Output Level:Unbalanced: +4dBV, typical;
- Maximum Output Level:+11dBV, typical;
- Output Impedance:150 Ohm
- Load Impedance:600 Ohm minimum

Headphone Outputs: 1 & 2 (at Maximum Volume; Into 100 Ohm load):

- Frequency Response:22Hz to 22kHz (+/-1dB)
- Power into Ohms:90 mW into 100 Ohms
- THD+N:<0.06% (-66dB)
- Signal-to-Noise Ratio:-90dB, A-weighted
- Max Output Level into 100 Ohms:+2.0dBV, typical
- Output Impedance:75 Ohm
- Load Impedance:32 to 600 Ohms

Specifications *(Continues)*

Cube DJ

CUBE Series

Mic Inputs (at Minimum Gain):

Frequency Response:	22Hz to 22kHz (+/-0.1dB)
Dynamic Range:	100dB, A-weighted
Signal-to-Noise Ratio:	-100dB, A-weighted
THD+N:	<0.0061% (-90dB)
Crosstalk:	-87dB @ 1kHz
Input Impedance:	Mic in: 1.8K Ohms, typical
Adjustable	Gain: +34dB
Total Gain Range:	+50dB

Line Inputs 1-4(Unbanced):

Frequency Response:	22Hz to 22kHz (+/-0.1dB)
Dynamic Range:	100dB, A-weighted
Signal-to-Noise Ratio:	-100dB, A-weighted
THD+N:	<0.0061% (-90dB)
Crosstalk:	-87dB @ 1kHz
Nominal Input Level:	Unbalanced: +4dBV, typical;
Maximum Input level:	Unbalanced: +11dBV, typical;
Input Impedance:	10K Ohms, typical

Phono Inputs 1-4:

Frequency Response:	22Hz to 22kHz (+/-0.1dB)
Dynamic Range:	100dB, A-weighted
Signal-to-Noise Ratio:	-100dB, A-weighted
THD+N:	<0.0061% (-90dB)
Crosstalk:	-87dB @ 1kHz
Nominal Input Level:	Unbalanced: -29dBV, typical;
Maximum Input level:	Unbalanced: -22dBV, typical;
Input Impedance:	47K Ohms, typical

Line Outputs 1-4 (Unbanced):

Frequency Response:	22Hz to 22kHz (+/-0.1dB)
Dynamic Range:	102dB, A-weighted
Signal-to-Noise Ratio:	-102dB, A-weighted
THD+N:	<0.003% (-90 dB)
Crosstalk:	-100dB @ 1kHz
Nominal Output Level:	Unbalanced: +4dBV, typical;
Maximum Output Level:	+11dBV, typical;
Output Impedance:	150 Ohm
Load Impedance:	600 Ohm minimum

Headphone Outputs: 1 & 2 (at Maximum Volume; Into 100 Ohm load):

Frequency Response:	22Hz to 22kHz (+/-1dB)
Power into Ohms:	90 mW into 100 Ohms
THD+N:	<0.06% (-66dB)
Signal-to-Noise Ratio:	-90dB, A-weighted
Max Output Level into 100 Ohms:	+2.0dBV, typical
Output Impedance:	75 Ohm
Load Impedance:	32 to 600 Ohms

Services

If your Cube series audio interface needs servicing, follow these instructions.

1. Ensure the problem is not related to operation error or external system devices.
2. Keep this owner's manual. We don't need it to repair the unit.
3. Pack the unit in its original packaging including end card and box. This is very important. If you have lost the packaging, please make sure you have packed the unit properly. ICON is not responsible for any damage that occurs due to non-factory packing.
4. Ship to the ICON tech support center or the local return authorization.

U.S. OFFICE:

ICON Digital Corp.
2222 Pleasant View Road Suite #1
Middleton, WI 53562 USA

ASIA OFFICE:

ICON (Asia) Corp.
Unit 807-810, 8/F., Sunley Centre,
No. 9 Wing Yin Street, Kwai Chung, NT., Hong Kong.

5. For additional update information please visit our website at:
www.icon-global.com



iCON®

www.icon-global.com

info@icon-global.com

