

Marshall

Broadcast A/V Division

CV620-TBI/TWI

Auto Track, Follow and Frame

20x PTZ Camera

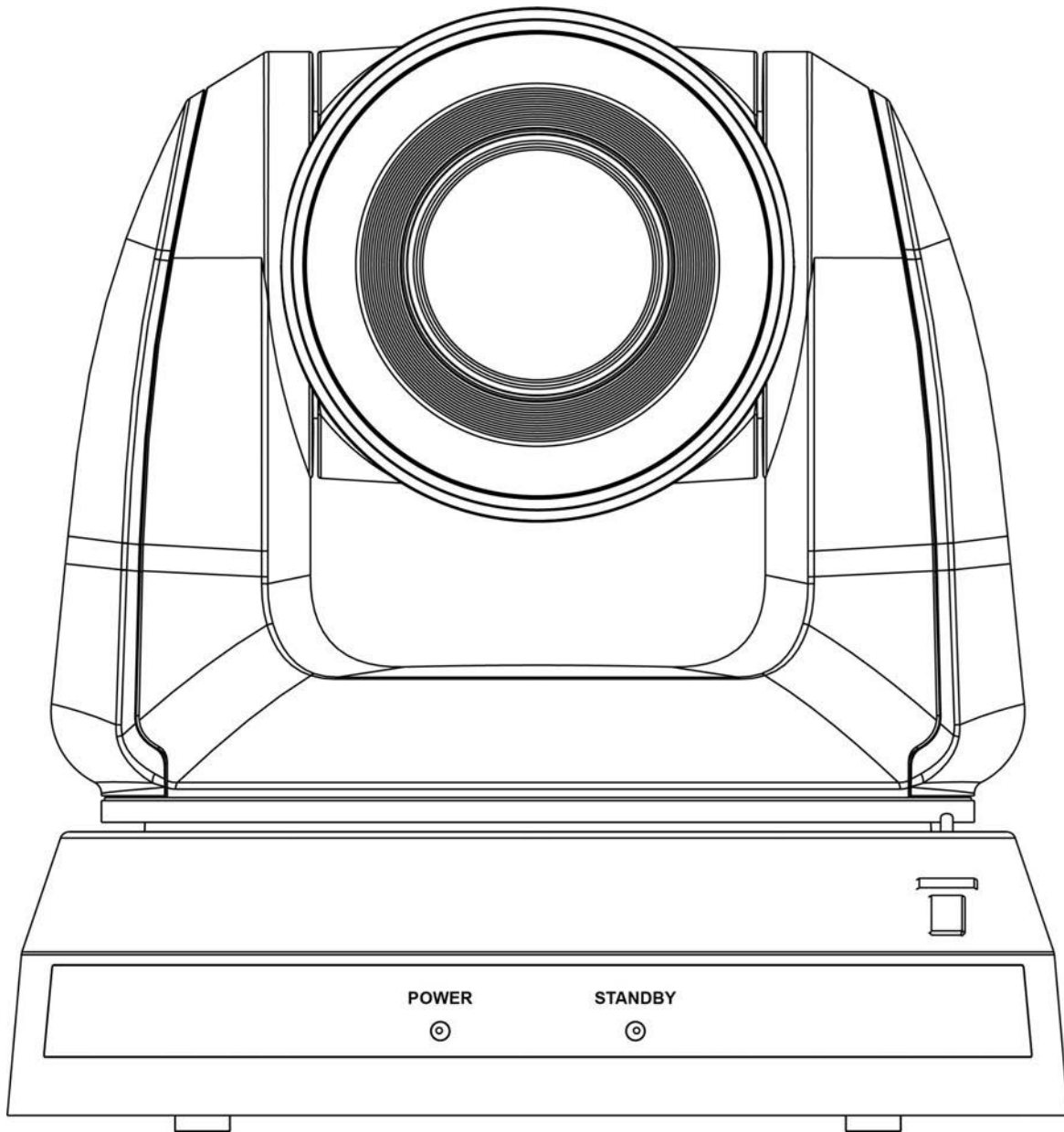

User Manual

Table of Contents

Chapter 1	Package Contents.....	3
Chapter 2	Product Overview and Interface.....	4
	2.1 I/O functions Introduction.....	4
	2.2 Description of LED indicator.....	5
Chapter 3	Instruction for installation.....	6
	3.1 Scenario	6
	3.2 Camera Size	6
	3.3 Preparation before installation.....	7
	3.4 Instruction for installation	7
Chapter 4	Introduction of Remote Control and Setting Menu.....	15
	4.1 Remote Control	15
	4.2 Setting Menu	16
Chapter 5	Network Function Settings Description	20
	5.1 Connecting Camera to Network.....	20
	5.2 Web Page Menu Function Description.....	22
Chapter 6	DIP Switch Setting.....	35
	6.1 OUTPUT Switch.....	35
	6.2 IR SELECT.....	35
	6.3 Camera Address Selector	35
	6.4 System Switch.....	35
Chapter 7	Troubleshooting	36
Chapter 8	Safety Instructions.....	37
	Copyright Information.....	38

CHAPTER 1: PACKAGE CONTENTS

Camera

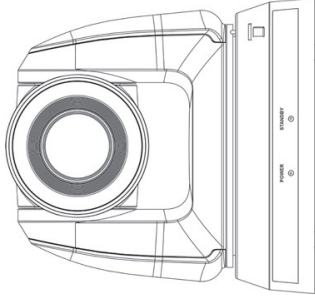

Remote

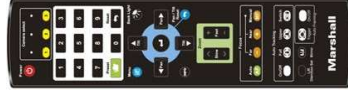

Power Adapter

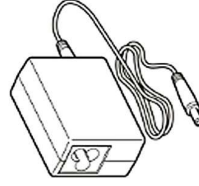

Power Cord



RS-422 Connector

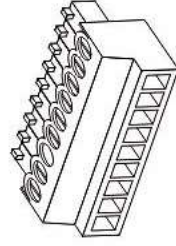

Metal Plate A

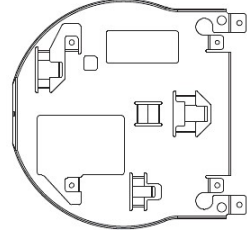

Metal Plate B

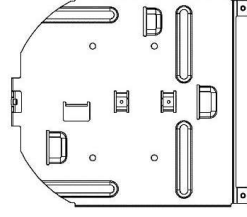

M3 Screws

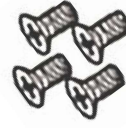

Silver x 8 / Black x 2

CHAPTER 2: PRODUCT OVERVIEW AND INTERFACE

2.1 I/O Functions Introduction

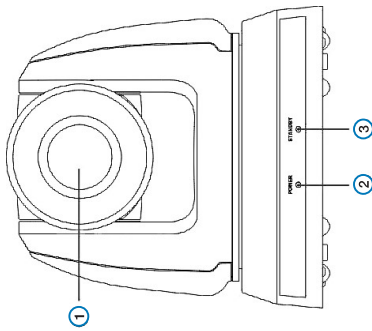

Item	Function Descriptions
1. Camera lens	Camera lens
2. Power LED	Status Light, please refer to 2.2 Description of LED Indicator .
3. Standby LED	Status Light, please refer to 2.2 Description of LED Indicator .

Item	Function Descriptions
4. Kensington lock	Safety lock slot
5. Power input	AC power supply connecting port
6. Audio In	Support Line In/Mic In
7. RS-232 output	RS-232 output port, up to 7 cameras can be connected in a serial connection using Visca
8. RS-232 input	RS-232 input port, up to 7 cameras can be connected in a serial connection using Visca
9. RS-422 connecting	RS-422 connecting port, up to 7 cameras can be connected in a serial connection
10. Network port	Support IEEE 802.3at PoE + power supply
11. HDMI output	HDMI output (supports Audio embedding)
12. 3G-SDI	3G-SDI output
13. OUTPUT Switch	Adjusts the resolution settings. Default is 1920 x 1080p at 60fps
14. IR SELECT	Remote control ID setting to match IR remote Camera Select. Camera can be controlled via IR remote only when it corresponds to the Camera Select on the remote control

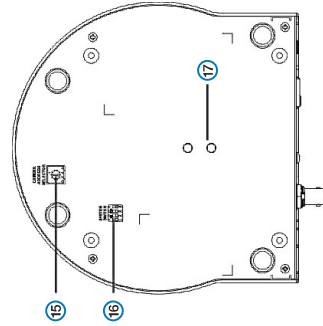
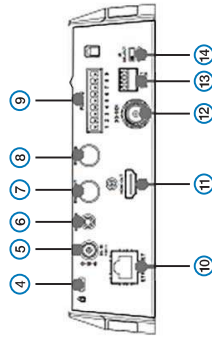

Item	Function Descriptions
15. Camera Address Selectors	Camera ID Setting
16. SYSTEM Switch	System DIP Setting
17. Tripod lock hole	mounted on a 1/4"-20 UNC tripod (keeps it secure)

2.2 Description of LED Indicator

Status	Standby	Power
Startup in progress	Green light	Orange light
In use	Green light	No indicator
In standby mode	No indicator	Orange light
Tally mode 1	Red light	Red light
Tally mode 2	Green light	Red light
Tracking Mode	Flickering green light	No indicator

Note: The Tally mode can be enabled via RS-232 command control. Please download the file for RS-232 Command Set from the Marshall website

CHAPTER 3: INSTRUCTION FOR INSTALLATION

3.1 Scenario

3.1.1 Applicable distance of CV620-TBI to target: 4~15m, best tracking distance recommended to be 8m from target to capture.

3.1.2 Mounting height: 2~3m, best height recommended to be 2.4m from target to capture.

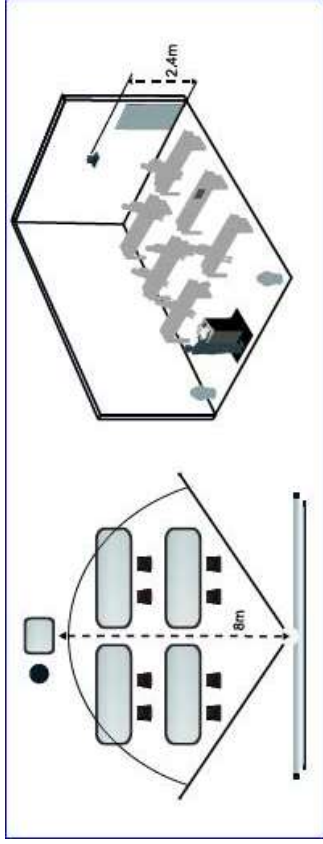

Note: To maintain the best tracking performance, avoid posters, screens, monitors and televisions with images of people in the background.

3.2 Camera Size

- Length x Width x Height: 174 x 187 x 192 mm
- Weight: 2.0 Kg

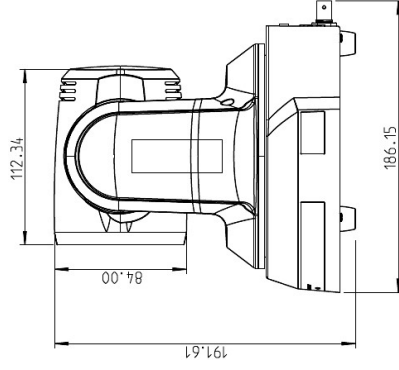
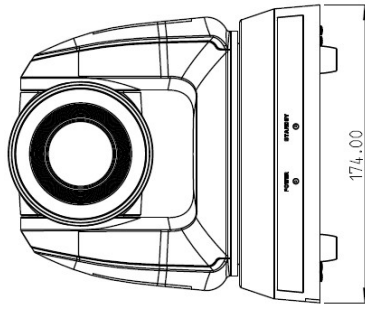

3.2.1 Dimensions of the bottom of the machine

The camera can be mounted on a 1/4"-20 UNC PTZ tripod deck by using the lock holes on the bottom of the camera.

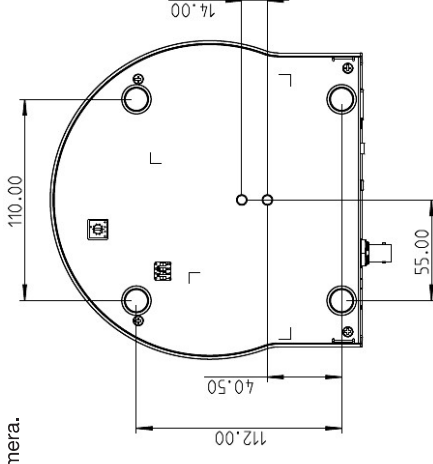

3.3 Preparation before installation

Installation and connection of HD camera requires special skills. To install by yourself, please follow necessary steps, to ensure steady and secure installation of CV620-TBI camera, and pay attention to safety guidelines to avoid drops or accidental mishaps.

- ✓ Survey environment for safe installation. Please do not install the device on an unstable ceiling or in a place where the device is in danger of falling to avoid any accidents.
- ✓ Check whether accessories in the box are complete. Please contact the supplier for any shortage, and make sure to keep the accessories in the box intact for future use.
- ✓ Choose a proper place for installation of camera in advance. Please determine an installation area according to the following requirements:
 - Confirm the position for the object to be captured
 - Confirm whether the camera is set at a proper distance from light sources

3.4 Instruction for installation

3.4.1 I would like to install camera on the desk

3.4.1.1 Precautions for installation:

- Please install the machine on a flat desk.
 - Do not grab or hold the camera by the head.
 - Do not rotate the camera head by hand.
- Improper rotation may result in breakdown of the camera gears.

- Metal plate B - ceiling side

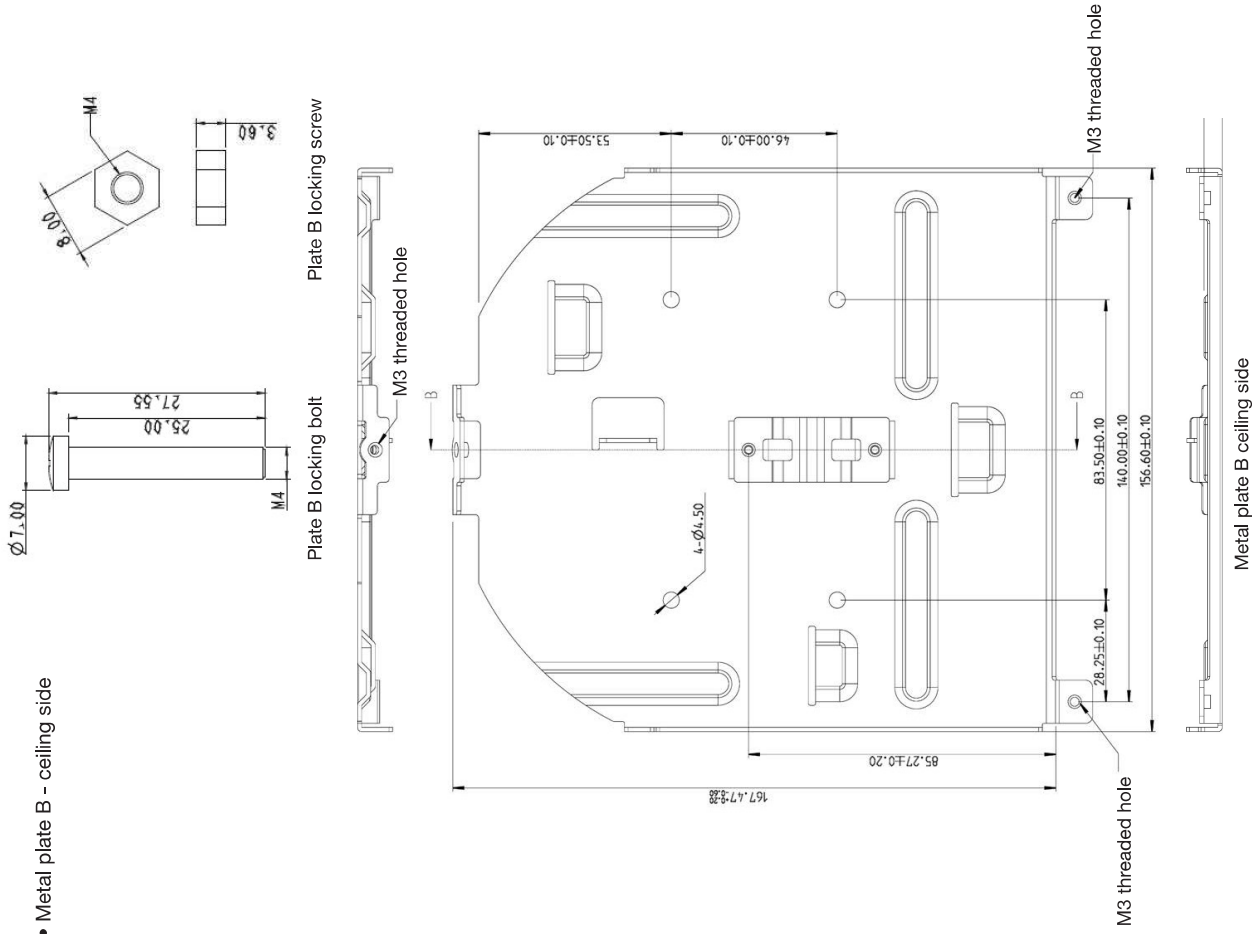

3.4.2.3 Precautions for Installation

- Before installation, confirm the orientation of the machine relative to the subjects to be captured.
- It is recommended that the machine be set at 1.5 meters or more from the subject. Please choose a distance most appropriate to the zoom settings of camera.

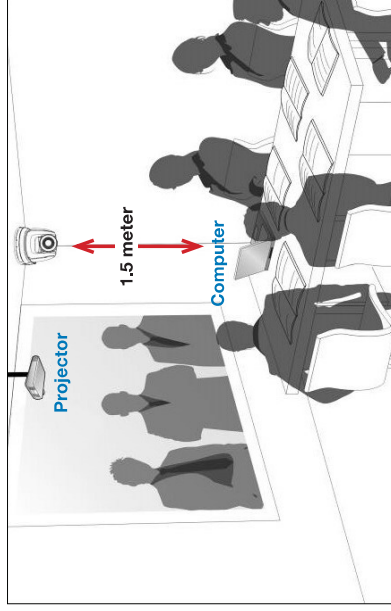

- The machine (including metal plates) is weighed at about 2.5 kg. If it is to be installed on the ceiling, please use the hanger that has obtained UL security approval to prevent the machine from breaking loose and falling.
- Please check camera on a regular basis to ensure it is secure and stays secure.

3.4.2.4 Installation Steps

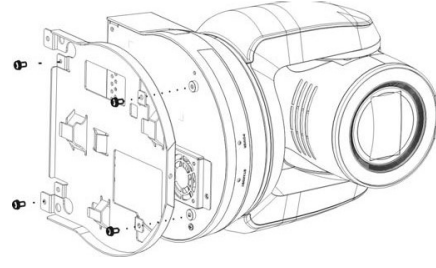

1. Adjust resolution on DIP switch before installing camera
Note: Please refer to Chapter 6 DIP Switch Setting for the relevant descriptions on DIP switch
2. Fix the plate A on the machine base with 4x M3 silver screws
3. Lock the metal plate B on ceiling mounted hanger
Note: (1) Please use the hanger that has obtained UL security approval
 (2) Reserve the hole for the connecting wires
4. Combine the metal plate A and the metal plate B
 (1) Push the metal plate A up to the ceiling and then to the right to latch the metal plate B
 (2) And then secure with 2x M3 silver screws and 1x M3 black screw

3.4.2.5 How to Remove

1. Remove the connecting wires from the camera
2. Uninstall the camera together with the ceiling, loosen the three screws that fix the metal plates A and B and push to the left to remove the machine

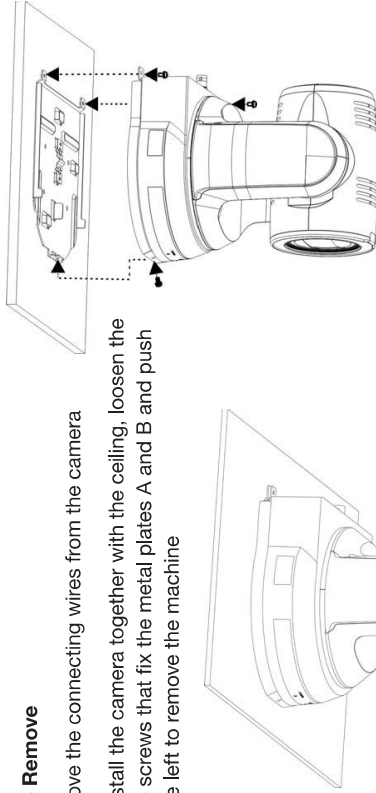

3. Then remove the screws on the hanger and the machine

3.4.3 Connecting Devices

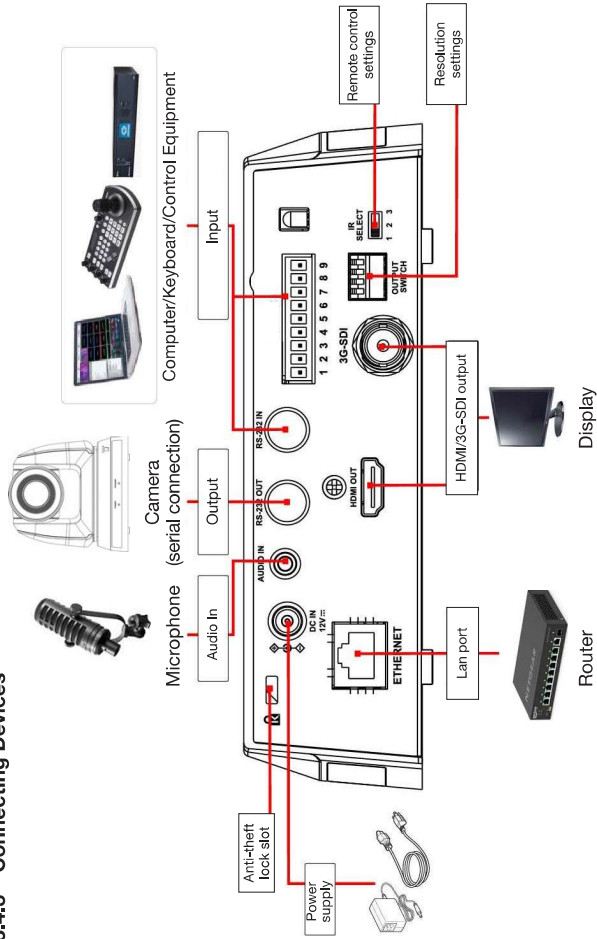

3.4.4 RS-232 connection (up to 7 cameras can be connected)

Note: Only one of RS-422/RS-232 can be selected for control, please refer to 6.4 System Switch, DIP1 setting

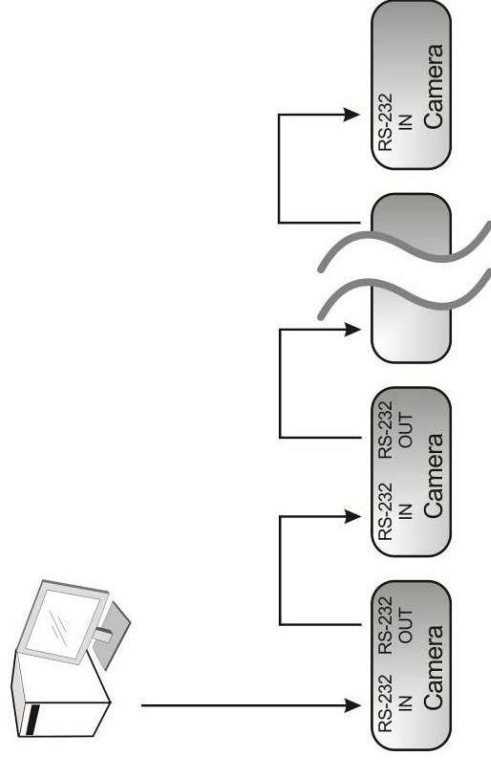

▶ RS-232 IN Pins Instructions

NO	Pins	Signals
1	DTR	Data Transmission Ready
2	DSR	Data Set Ready
3	TXD	Transmit Data
4	GND	Ground
5	RXD	Receive Data
6	GND	Ground
7	IR OUT	IR Commander Signal
8	N.C.	No Connection



▶ RS-232 OUT Pins Instructions

NO	Pins	Signals
1	DTR	Data Transmission Ready
2	DSR	Data Set Ready
3	TXD	Transmit Data
4	GND	Ground
5	RXD	Receive Data
6	GND	Ground
7	OPEN	Reserved
8	OPEN	Reserved



▶ RS-232 Connection Instructions

RS-232 IN of VC

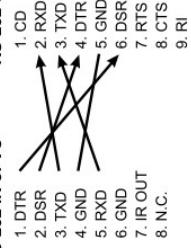

▶ RS-232 Connection Instructions

RS-232 IN of Next Camera

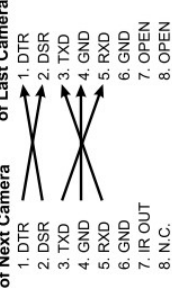

RS-232 of PC

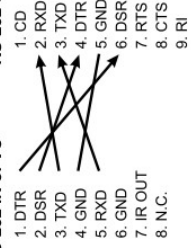

3.4.5 RS-232 connection (up to 7 cameras can be connected)

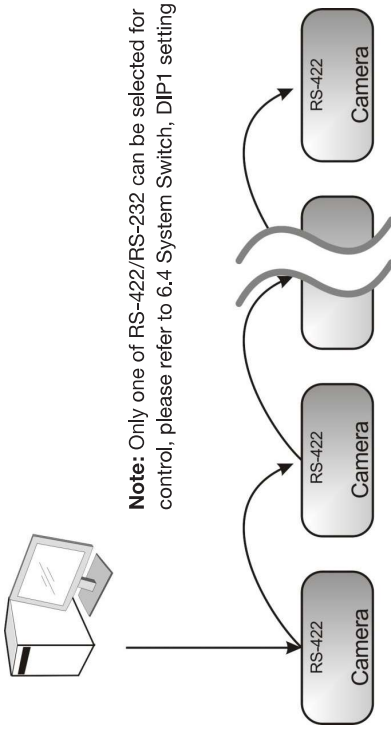

RS-422 Pins Instructions

Pin NO.	Function
1	RXD OUT-
2	RXD OUT+
3	TXD OUT-
4	TXD OUT+
5	GND
6	RXD IN-
7	RXD IN+
8	TXD IN-
9	TXD IN+



RS-422 Connection Instructions

Applicable to Marshall Compact Camera Controller

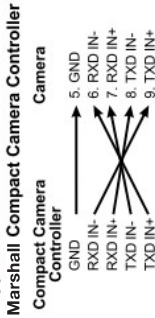

RS-422 Connection Instructions

Applicable to SONY Compact Camera Controller

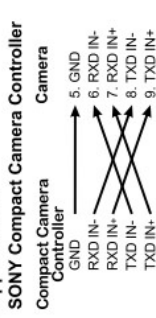

RS-422 Serial Connection

Up to seven cameras can be daisy-chained

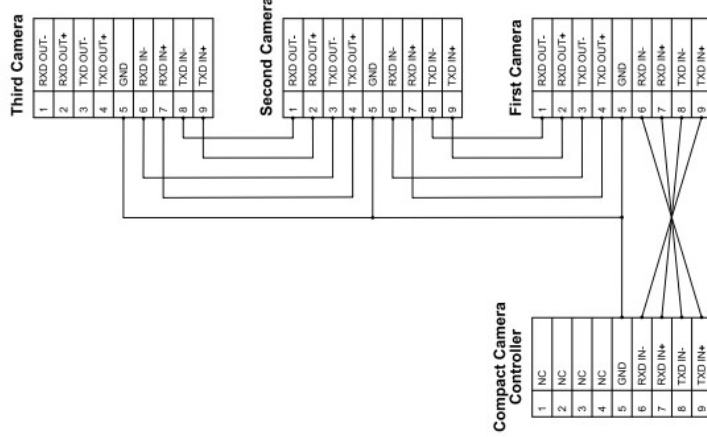

CHAPTER 4: REMOTE CONTROL AND SETTINGS

4.1 Remote Control

The functions below are listed alphabetically

Item	Description
◀ ▶ ▲ ▼	Move the lens
Auto Tracking	<ul style="list-style-type: none"> On/Off: Enable/Disable Auto Tracking Full: Full body tracking Upper: Half body tracking Switch: Switch tracking object
Auto Framing	<ul style="list-style-type: none"> On/Off: Enable/Disable Smart viewfinder Trigger: Manual framing correction
Back Light	Turn on/off back light compensation
Camera Select	Choose camera ID 1 ~ 3
Focus	<ul style="list-style-type: none"> Auto: Auto focus Manual: Enable Manual Focus Far/Near: Adjust the focal length in Manual
Freeze	Freeze the screen
Home-Enter	Go back to main page/ Execute
Info	Status information
L/R Direction Set	L/R direction /Normal
Menu	Display OSD Menu
Mirror	Rotate image (OFF/ Mirror/ Flip/ Rotate
Pan/Tilt Reset	Clear the Pan/Tilt Setting
Picture	Switch image effect (OFF/ Neg/ B&W)
Power	Power Switch
Preset	Appoint an ID (0~9) to save the current position data
Reset	Appoint an ID (0~9) to save the current position data
Zoom-Fast	<ul style="list-style-type: none"> On/Off: Enable/Disable Auto Tracking Full: Full body tracking

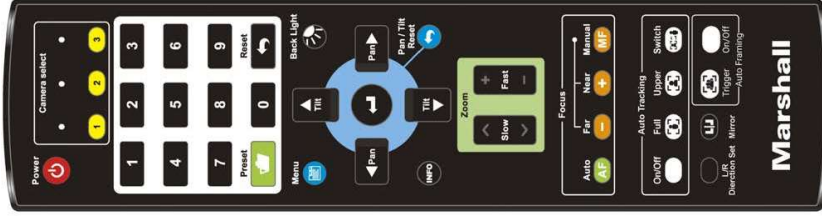

4.2 Setting Menu

The camera can be mounted on a 1/4"-20 UNC PTZ tripod deck by using the lock holes on the bottom of the camera.

1 st Level Major Items	2 nd Level Minor Items	3 rd Level Adjustment Values	Function Descriptions
Exposure	Mode	<u>Full Auto</u> / Shutter Pri / Iris Pri / Manual / White Board	Exposure mode setting
	Exposure Comp.	On / <u>Off</u>	Turn on/off Exposure Comp.
	Exposure Comp. Level	-6- <u>C</u> -4	The value can be adjusted after Exposure Comp. is activated
	Shutter Pri	60/30 mode 50/25 mode 1/10000-1/1	Adjustable when the Exposure mode is set to Shutter Pri
	Iris Pri	<u>F1.6</u> -F6.3	Adjustable when the Exposure mode is set to Iris Pri
	Manual Gain	<u>0</u> -45dB	Adjustable when the Exposure mode is set to Manual Pri
	Manual Speed	60/30 mode 50/25 mode 1/10000-1/1	Manually set the shutter
	Manual Iris	<u>F1.6</u> -F6.3	Manually set the iris
	Gain Limit	9- <u>C</u> -45dB	Max. limit value of electron gain
	Iris Limit	F1.6- <u>C</u> -F6.3	Max. limit value of iris
	WDR	<u>Off</u> / 1/2 / 3 / 4	WDR settings
	Mode	1. <u>Auto</u> 2. Indoor 3. Outdoor 4. One Push WB 5. ATW 6. Manual 7. Sodium Lamp 8. 3000K 9. 4300K 10. 5000K 11. 6500K 12. 8000K 13. WideAuto	Select the color temperature mode 1. 4000k ~ 7000k 2. 3200k 3. 5800k 4. 1700k ~ 10000k 5. 1700k ~ 10000k 6. Custom 7. 2800k
	White Balance	One Push Trigger	<u>ENTER</u>
Manual Red		0- <u>C</u> -128	Adjustable when the white balance mode is set to Manual
Manual Blue		0- <u>C</u> -128	Adjustable when the white balance mode is set to Manual

1 st Level Major Items	2 nd Level Minor Items	3 rd Level Adjustment Values	Function Descriptions
Tracking	Mode	<u>Auto Tracking</u> / Smart viewfinder	
	Picture effect	<u>Off</u> / Neg / B&W	
	Sharpness	0- <u>A</u> -14	
	2D NR	Off / 1 / 2 / 3	
	3D NR	Off / Low / <u>Standard</u> / Highest	
	Image Mode	Mode 1 ~ 6 / Self-defined	The user may customize his/her desired image mode
	Image Mode Load	Mode 1 ~ 6	Adjustable when the Image mode is set to Custom . After selected, the corresponding Image mode parameters will be read and applied to Custom.
	Brightness	0- <u>C</u> -25	Adjustable when the image mode is set to Custom
	Contrast	0- <u>C</u> -25	Adjustable when the Image mode is set to Custom
	Saturation	0- <u>C</u> -25	Adjustable when the Image mode is set to Custom
	Black Level	Type 1 ~ 5 / <u>Off</u>	Adjustable when the Image mode is set to Custom
	Gamma	0- <u>C</u> -3	Adjustable when the Image mode is set to Custom
	Skin Tone	0- <u>C</u> -5	
Pan Tilt Zoom	Pan/Tilt Limit	On / <u>Off</u>	Turn on/off the angle limit setting
	Pan Right Limit	0- <u>170</u>	Limit the right angle
	Pan Left Limit	- <u>170</u> -0	Limit the left angle
	Tilt UP Limit	0- <u>90</u>	Limit the upward angle
	Tilt Down Limit	- <u>30</u> -0	Limit the downward angle
	Pan Flip	On / <u>Off</u>	After it is activated, the Pan command will be reverse
	Tilt Flip	On / <u>Off</u>	After it is activated, the Tilt command will be reverse
	Preset Speed	5- <u>C</u> -300 deg/sec	Set the PTZ rotation speed when Preset is performed
	PTZ Speed Comp	On / <u>Off</u>	Set the Pan/Tilt moving speed to vary from the zoom position
	Zoom Limit	<u>x1</u> -x20	Set the D-zoom limit
	Mirror	<u>Off</u> / Mirror / Flip / Mirror + Flip	Set the mode at which the image is turned
	AF Sensitivity	Low / <u>Mid</u> / High	For AF triggering speed, the higher the speed is, the faster AF is triggered
	AF Frame	Center Area / <u>All Area</u>	AF frame setting, when Central Area was set as AF frame, focusing will be on the center of the screen. When Full Frame was set as AF frame, focusing will be calculated based on the full screen
Zoom tracking	On / <u>Off</u>	This function can be set in the Manual Focus (MF) mode In Manual Focus mode, check whether focus is enabled during lens zooming	

1 st Level Major Items	2 nd Level Minor Items	3 rd Level Adjustment Values	Function Descriptions
Ethernet	PTZ Assist	On / <u>Off</u>	This function can only be enabled in the Manual Focus (MF) mode. When PTZ Assist is enabled and PTZ control is in operation, the focus will be triggered. The focus will not be triggered when the scene changes.
	SMART AF	On / <u>Off</u>	Turn on this function and AF will mainly focus on the face.
	DHCP	<u>On</u> / Off	Enable/Disable the dynamic host configuration.
	IP Address	<u>192.168.100.150</u>	Press [ENTER] to be in modify mode; select the item to be modified using the up and down keys, and modify the value using the left and right keys or the numeric keys.
Ethernet	Subnet mask	<u>255.255.255.0</u>	
	Gateway	<u>192.168.100.254</u>	
Audio	Audio In	<u>Line In</u> / Mic In	Set Audio In
	Audio Enable	On / <u>Off</u>	Turn on/off audio output
	Audio Volume	0~ <u>C</u> -10	Audio Volume Setting
	Audio Delay	On / <u>Off</u>	When the audio is not synchronized with the video, enable this function to set the audio delay time.
	Audio Delay Time (ms)	<u>1</u> ~500ms	Set audio delay time
	Encode Sample Rate	1. <u>48 KHz(AAC)</u> 2. 44.1 KHz(AAC) 3. 16 KHz(AAC) 4. 16 KHz(G.711) 5. 8 KHz(G.711)	Set the encode type and sample rate <Remark> SDI supports the audio output of 48 KHz only
	Prompt	On / <u>Off</u>	Turn on/off the prompt information on the display
	IR Receive	<u>On</u> / Off	Turn on/off the infrared reception. When it is Off, the remote control will not be able to control the camera. At this moment, turn off and then turn on the power to restore control of the remote control.
	Motionless Preset	On / <u>Off</u>	When the function is enabled, the screen will Freeze when Preset is executed. Freeze will be released after Preset is completed.
	Tally Lamp	<u>On</u> / Off	Select Off and it will not be triggered by commands to turn on or off.
System	Language	<u>English</u> / Chinese	
	Initial Position	<u>Last operation</u> / First default value	Select the camera lens to return to the Last operated position or the First preset position after POWER ON
	Output Mode	<u>1080p 60/59.94/50/30/29.97/25</u> 1080i 60/59.94/50 720p 60/59.94/50	Choose the output resolution
Control Device	Encoder / <u>Controller</u>	Control Device setting. Controller: for joystick Encoder: for tracking system	

1 st Level Major Items	2 nd Level Minor Items	3 rd Level Adjustment Values	Function Descriptions
Status	Protocol	<u>Protocol V</u> / Pelco D	Protocol V=VISCA
	Pelco D Address	<u>4</u> ~255	The Protocol set to Pelco D allows the camera ID address to be assigned
	Factory Reset	On / <u>Off</u>	Resume the factory default setting
Status			Display the current setting status

CHAPTER 5: NETWORK FUNCTIONS SETTINGS

5.1 Connecting Camera to Network

5.1.1 Remote Control

Two common connection methods are show below:

1. Connecting via switch or router

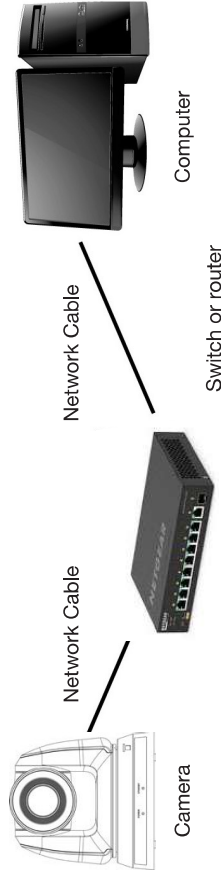

2. To connect directly through network cable, the IP address of the computer should be changed so that it is on the same network segment as the camera.

E.g: The factory-preset default IP address of the camera is 192.168.100.150. The computer IP address must be set with the same network segment, such as 192.168.100.101, so that the computer can be connected correctly with the camera

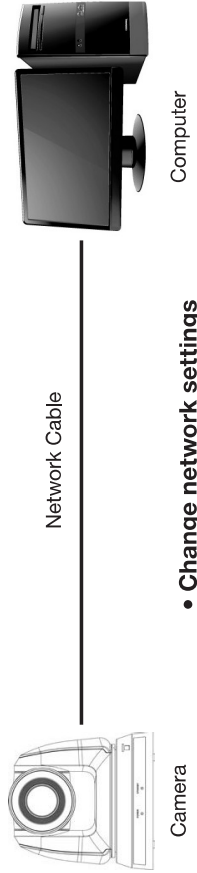

- Change network settings

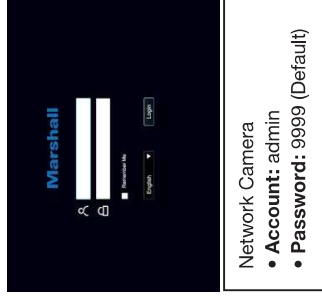
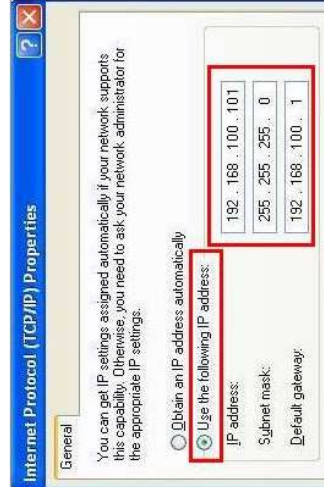

5.1.2 Using the Browser to View the Images

- Open the browser, and enter the IP address of the camera in the address bar

E.g.: <http://192.168.100.150> (default IP address)

- Enter administrator's account and password

Note: For the first-time login, refer to 5.2.9 System Settings - User to change the default password

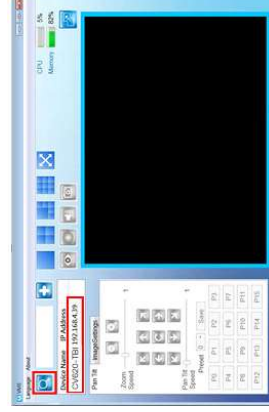

5.1.3 Using Marshall VMS Software to View the Images

- Open MARSHALL VMS software (Please download from the Marshall official website)
- Search Camera: Press [automatically search for the device] button to locate the Camera
- Click camera in the list and start operation after connecting to network

Note: When using automatic search, the camera and computer must be in the same network segment, e.g.: 192.168.4.X

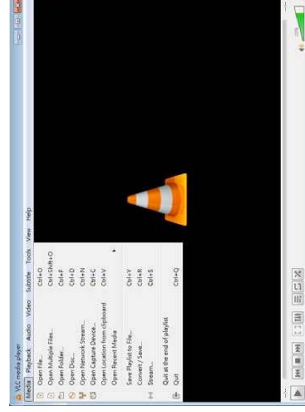

5.1.4 Using RTSP Player to View the Images

RTSP connections can be made using free software, e.g.: VLC, Quick Time, PotPlayer, etc. RTSP connection address formats are as follows:

- RTSP main stream (h264)=>rtsp://VC IP Address:8557/h264
- RTSP second stream (h264) =>rtsp://VC IP Address:8556/h264
- RTSP second stream (MJPEG) or single stream in MJPEG=>rtsp://VC IP Address:8555/mjpeg

If password authentication is enabled, the RTSP connection address is as follows:

- rtsp://Username:Password@VC IP address:port/hevc
- rtsp://Username:Password@VC IP address:port/mjpeg

Note: To enable password authentication function, please refer to 5.2.5 Setting - Streaming

Example: Open the VLC software, click [Open Network Streaming], and enter the URL: rtsp://192.168.100.150:8557/h264

5.2 Web Page Menu Function Description

5.2.1 Login Screen

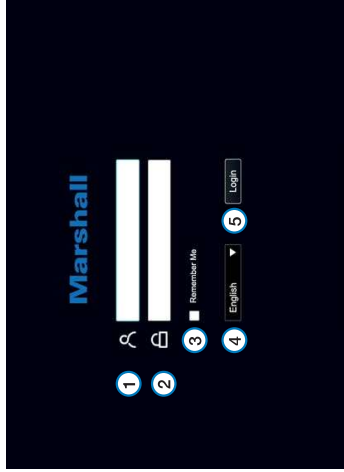

No	Item	Function Descriptions
1	User Login Account	Enter user login account (default: admin)
2	User Password	Enter user password (default: 9999) <Remark> For the first-time login, please refer to 5.2.9 System Settings - User to change the default password
3	Remember user account and password	Save user login account and password to the browser. When you log in next time, there is no need to re-enter them
4	Language	Supporting English/Traditional Chinese/Simplified Chinese
5	Login	Log into the administrator screen on the website

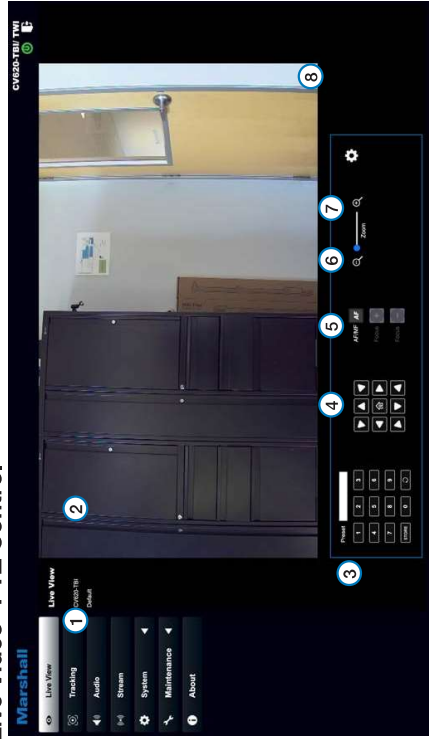

5.2.2 Live Video- PTZ Control



No	Item	Function Descriptions
1	Camera ID/location	Display camera ID/location Please refer to 5.2.6 System Settings - Device
2	Preview window	Display the screen currently captured by the camera
3	Preset setting	Select the number first and then select SAVE or LOAD
4	Pan/Tilt setting	Adjust the Pan/Tilt position of the camera screen

5	Zoom	Zoom In/Zoom Out ratio
6	AF/AF	Switch AF/AF
7	Camera Setting	Please refer to 5.2.2.1 Camera Setting
8	Enlarge the preview window	Zooming in/out the preview image

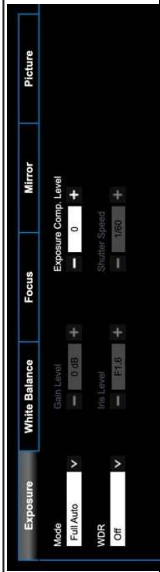
5.2.2 Camera Setting

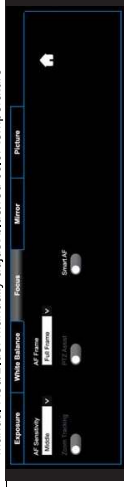
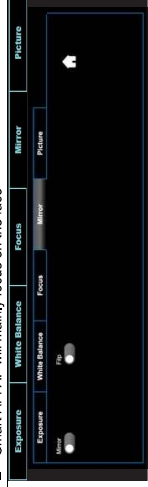
No	Item	Function Descriptions
1	Exposure	 <ul style="list-style-type: none"> Mode: Select exposure mode (Full Auto / Shutter Pri / Iris Pri / Manual) Gain Level: Adjust the gain level (adjustable only under the "Manual") Exposure Comp. Level: Select exposure compensation level WDR: Set the level of wide dynamic range (WDR) in order to obtain better images Iris Level: Adjust the size of aperture (adjustable only under the "Manual" or "Aperture Priority") Shutter Speed: Adjust the shutter speed (adjustable only under the "Manual" or "Shutter Priority")
2	White Balance	 <ul style="list-style-type: none"> Mode: Select the color temperature mode One Push WB: Single color temperature execution adjustment (adjustable only under the "One Push WB") Manual Red/Blue: Manually adjust blue/red color temperature
3	Focus	 <ul style="list-style-type: none"> AF Sensitivity: Set automatic focus sensitivity AF Frame: Set automatic focus range Zoom Tracking: Check whether focus is enabled during lens zooming (can be set in Manual) PTZ Assist: Check whether auto focus is enabled if there is any changes of PTZ (can be set in Manual) <p><Remark> When PTZ Assist is enabled and PTZ control is in operation, the focus will be triggered. The focus will not be triggered when the scene changes</p> <p>Smart AF- AF will mainly focus on the face</p>
4	Mirror	 <ul style="list-style-type: none"> Flip: Set the mirror/flip mode

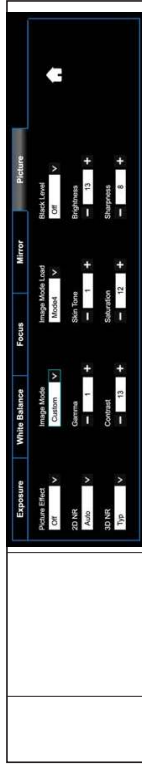

- Image Effect: Set picture effect, Off(Neg)/Black and White
- Image Mode: The user may customize his/her desired image mode
- Image Mode Load: Adjustable when the Image mode is set to Custom. After selected, the corresponding Image mode parameters will be read and applied to Custom
- 2D noise reduction: 2D noise reduction settings
- 3D noise reduction: 3D noise reduction settings
- Gamma: Gamma Level adjustment (Adjustable when the image mode is set to Custom)
- Black Level: Black Level adjustment (Adjustable when the image mode is set to Custom)
- Skin Tone: Skin Tone adjustment (Adjustable when the image mode is set to Custom)
- Brightness: Brightness adjustment of the image (Adjustable when the image mode is set to Custom)
- Contrast: Contrast adjustment (Adjustable when the image mode is set to Custom)
- Saturation: Saturation adjustment of the image (Adjustable when the image mode is set to Custom)
- Sharpness: Adjust the sharpness of the image

6 PTZ Control
Go back to PTZ Control page

5.2.3 Tracking

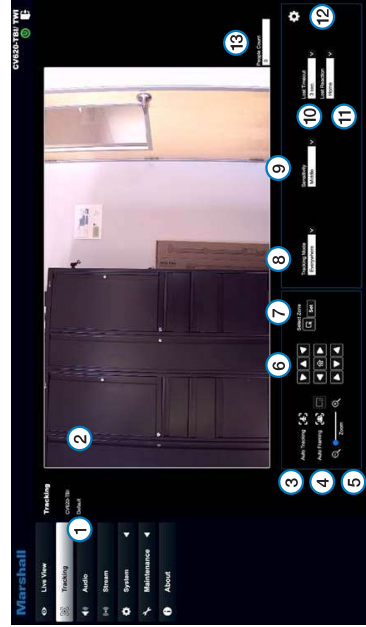

No	Item	Function Descriptions
1	Camera ID/location	Please refer to 5.2.6 System Settings - Device to display camera ID/location
2	Preview window	Display the screen currently captured by the camera <Remarks> Left-click the detected person in the screen to switch the tracking object. The tracking object is depicted with a green bounding box
3	Auto Tracking	Start/Stop Auto Tracking
4	Smart viewfinder	The camera will automatically detect the locations of people, and automatically adjust the zoom to the most appropriate size to accommodate all the participants according to change of the number of people in conference

		<Remark> If the image is not zoomed according to the actual number of people, please click to perform viewfinder correction.
5	Zoom ratio	Zoom In/Zoom Out ratio
6	Pan/Tilt setting	Adjust the Pan/Tilt position of the camera screen
7	Select Zone	Click and drag the mouse to select an area and then click the screen will be enlarged to the selected zone Click again to cancel enlarging the selected zone
8	Tracking Mode	Set the Tracking Mode (Everywhere/Stage/Partition/Viewfinder)
9	Sensitivity	Set tracking sensitivity
10	Lost Timeout	Set a delay for taking action after a tracking object is lost
11	Lost Reaction	Set the action after a tracking object is lost



12.1 Settings - Everywhere tracking

- Border Limitation Enable:
- Everywhere Body Tracking: Set Full/Half Body
- Body in Frame: Set the position of the person in the screen (Center/Left/Right)
- Custom Home: Pan/Tilt

Set the left/right border of the stage. Please refer to [5.2.3.1 Stage Tracking](#) for the setting steps

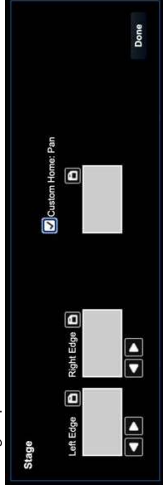

12.2 Settings - Stage Tracking

- Custom Home: Horizontal:

Set Partition Tracking. Up to 4 zones can be set.

When a person enters the zone of a partition, the camera switches to the partition. Tracking is not performed in the zone, but everywhere outside the partition. Please refer to [5.2.3.2 Partition Tracking](#) for the setting steps



12.3 Settings - Partition Tracking

- Partition Settings: Edit, save partition positions and preview the partition image. Click to enlarge the partition image, and then click the enlarge icon to cancel the preview.
- Number of Partitions: Set the number of partitions
- Initiate Partition: Set the initiate partition position

Display the number of people in the screen automatically calculated by the system

13 People Count

5.2.3.1 Stage





1. Select [Stage] for Tracking Mode, and click  box to select an area (orange box)



2. After the selection, click  to set, and the preview screen will display the selected area, then click  to access the settings



3. Set the Left/Right Border

- > Left Border: Click  to move the position and click  when finished
- > Right Border: Click  to move the position and click  when finished
- > Click  to complete the settings after setting the left/right border

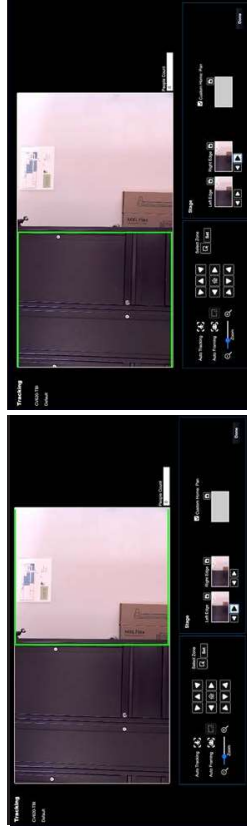

4. Click  to enable the Stage feature

Marshall

5.2.3.2 Partition

1. Select [Partition] for Tracking Mode, and click  to access the settings

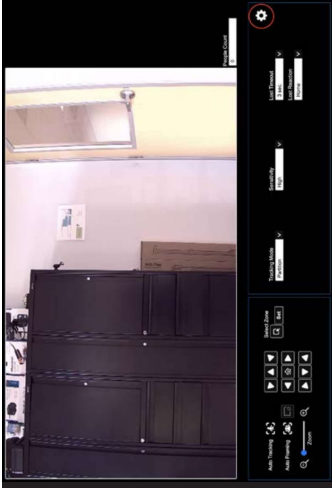

2. Use PTZ function to adjust to the screen to be partitioned, and then click  to save. The partition icon below will be changed to the saved position

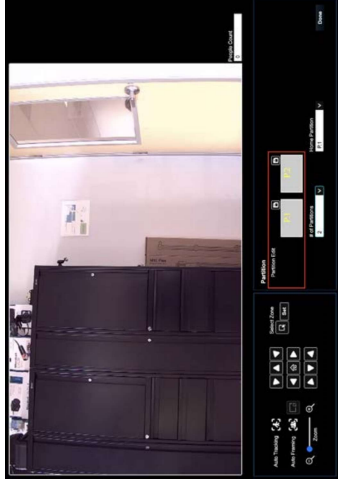

3. If you need to set other partitions, please continue using PTZ function to adjust the screen, and then click  to save

<Remark> If a red box is displayed when adjusting the screen, it means that the position overlaps with that of other partitions. Please adjust the screen again and save it when a green box is displayed

<Remark> Overlapping partition positions may cause abnormal tracking behavior

4. Click  to enable the Partition feature



5.2.4 Audio



No	Item	Function Descriptions
1	Audio Enable	Turn on/off sound
2	Soundtrack effect setting	Set MIC In/Line In
3	Encode Type	AAC / G.711 Set Encode sample rate <ul style="list-style-type: none"> 48 KHz (AAC) 44.1 KHz (AAC) 16 KHz (G.711) 8 KHz (G.711)
4	Encode sample rate	<Remark> SDI supports the audio output of 48 KHz (AAC) only
5	Audio Volume	Adjust Audio Volume
6	Audio Delay	Turn on/off audio delay
7	Audio Delay Time	Set the audio signal delay time (-1 ~ -500 ms)

5.2.5 Streaming

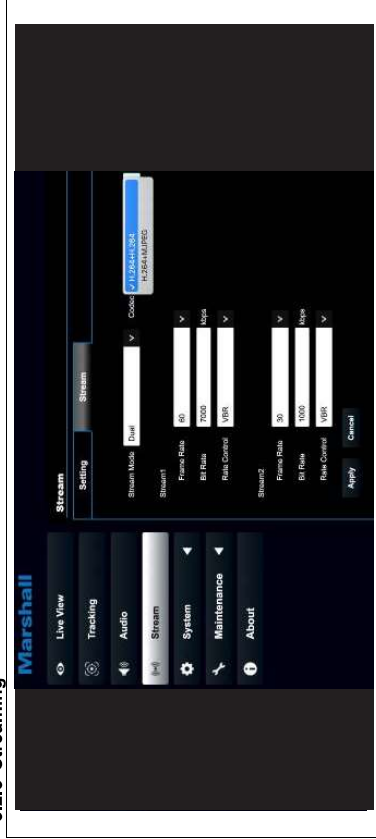

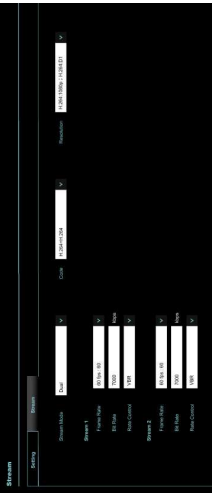
No	Item	Function Descriptions
1	RTMP/RTMPS Setting	Copy the RTMP web address provided by the RTMP service platform and paste it to the RTMP connection address to publish the camera images on the RTMP service platform To upload to YouTube for live streaming, please refer to 5.2.4 Settings - Audio to turn on the audio function <ul style="list-style-type: none"> Enable/Disable Multicast It is suggested to enable Multicast when the number of users online watching the image simultaneously is more than 4 <ul style="list-style-type: none"> Enable/Disable Password Authentication RTSP connection format can be found in 5.1.4 Using RTSP Player to View the Images <ul style="list-style-type: none"> The username/password is the same as the web login password of the camera, please refer to 5.2.9 System Settings - User to add/modify account information Set MPEG-TS format <Remark> Port must be set above 1024 <Remark> The following port has been used by the camera. Setting of the port may not connect correctly 8554, 8556, 8557, 8080, 80, 81, 9090, 23
2	RTSP Setting	1. Set the field of SRT and then check the item to open SRT streaming After the SRT streaming is opened, it will be connected automatically upon startup 2. The port number must be set above 1024 <Remark> The following port has been used by the camera. Setting of the port may not connect correctly 8554, 8556, 8557, 8080, 9090, 1935 3. Delay time is for 20 to 8000 microseconds. The default value is 120 microseconds
3	MPEG-TS Setting	Streaming Mode: Choose from Single/Dual stream Encode: Set encode format as H.264+H.264 (Dual)/H.264+MJPEG (Dual) Resolution: Set Resolution Rate Control: Setting according to the supported resolution Bit rate: > Streaming 1: Support 64 ~ 20,000 kbps > Streaming 2: Support 64 ~ 8,000 kbps Rate Control: CBR/VBR
4	SRT Setting	5.2.5.1 SVC description: Link Address rtsp://VC_IP_Address:Port/h264 <ul style="list-style-type: none"> 60Frame: rtsp://VC_IP_Address:8557/h264, E.g.: rtsp://192.168.100.150:8557/h264 30Frame: rtsp://VC_IP_Address:8601/h264, E.g.: rtsp://192.168.100.150:8601/h264 15Frame: rtsp://VC_IP_Address:8602/h264, E.g.: rtsp://192.168.100.150:8602/h264 7Frame: rtsp://VC_IP_Address:8603/h264, E.g.: rtsp://192.168.100.150:8603/h264 3Frame: rtsp://VC_IP_Address:8604/h264, E.g.: rtsp://192.168.100.150:8604/h264
5	Streaming Setting	

5.2.6 System Settings- Device

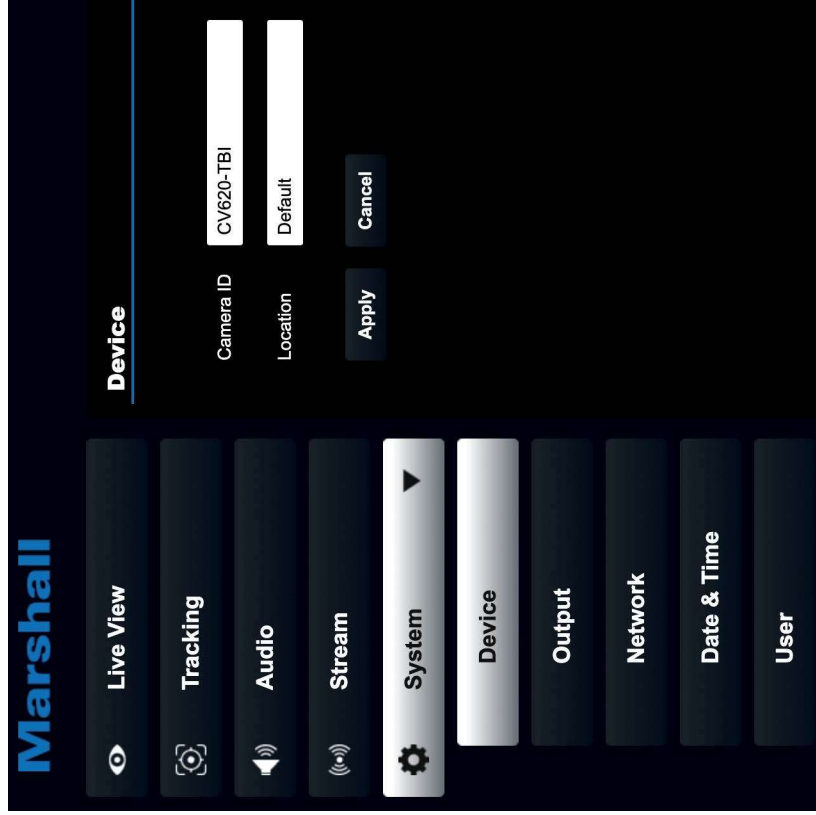

No	Item	Function Descriptions
1	Camera ID	Change camera ID here <ul style="list-style-type: none"> Supporting 1 - 30 characters for the camera ID Please mix uppercase and lowercase letters or numbers for characters. Special symbols such as "/" and "space" cannot be used
2	Location	Modify the location of the camera, such as Room 1 <ul style="list-style-type: none"> Supporting 1 - 30 characters for the camera location Please mix uppercase and lowercase letters or numbers for characters. Special symbols such as "/" and "space" cannot be used
3	Apply/Cancel	After the setting has been modified, select this button to apply the setting

5.2.7 System Settings- Network

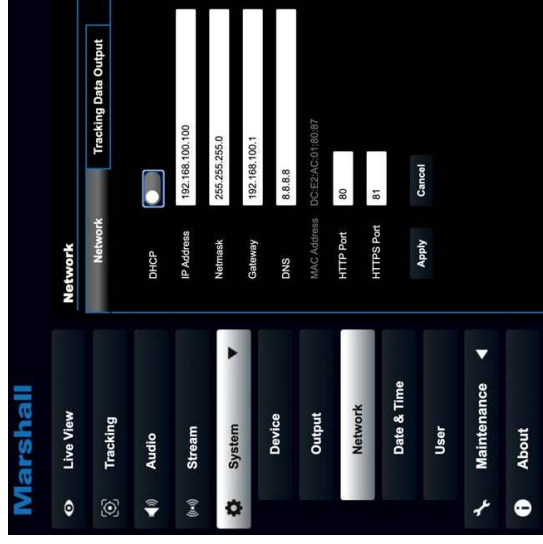

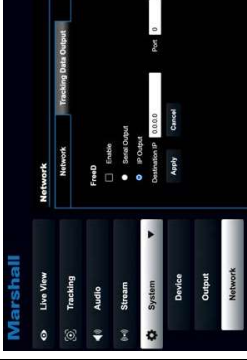
No	Item	Function Descriptions
1	DHCP	Network setting of camera. Change of setting is available when DHCP function is closed
2	HTTP port	Set HTTP port. The default Port value is 80
3	HTTPS port	Set HTTPS port. The default Port value is 81
4	Tracking Data Output	 <p>When enabled, PTZ position information can be reported when the camera moves</p> <ol style="list-style-type: none"> Serial Output: Please set the protocol to VISCA and the baud rate to 38400 IP output: Set the destination IP address and port <p><Remark> When Tracking Data Output is enabled, the camera performance may be affected.</p>

5.2.11 About

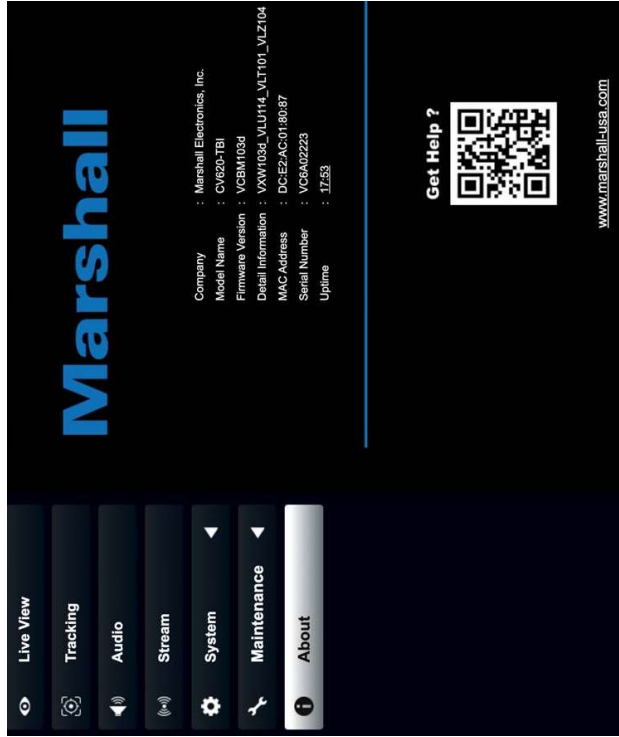

Function Descriptions

Display the firmware version, serial number, running time and other related information of the camera
For technical support, please scan the QRcode at the bottom right

CHAPTER 6: DIP SWITCH SETTING

6.1 OUTPUT Switch

Output Mode	Setting	Output Mode	Setting
1920x1080/60p		1920x1080/50p	
1920x1080/30p		1920x1080/25p	
1920x1080/60i		1920x1080/50i	
1280x720/60p		1280x720/50p	
1080/59.94p		1080/59.94i	
1080/29.97p		720/59.94p	



6.2 IR SELECT

ID	Setting
1	
2	
3	



6.3 Camera Address Selector

Setting	Function Descriptions
0-7	ID 0-7
8-9	Reserved



6.4 System Switch

Setting	功能說明
DIP 1	RS-232/RS-422 Communication Control OFF: RS-232 / ON: RS-422
DIP 2	IR signal output OFF: Off / ON: On
DIP 3	Communication baud rate OFF: 9600 / ON : 38400
DIP 4	Reserved



CHAPTER 7: TROUBLESHOOTING

This chapter describes problems you may encounter while using CV620-TBI/TWI. If you have questions, please refer to related chapters and follow all the suggested solutions. If the problem still occurred, please contact your distributors or the service center.



No.	Problems	Solutions
1.	Boot without power signal	<ol style="list-style-type: none"> 1. Make sure you have plugged in the power cord. 2. When using a PoE connection, ensure that the power supply supports POE+ (IEEE 802.3at) hubs.
2.	There is no image output from camera	<ol style="list-style-type: none"> 1. Check the power supply or PoE supply functions. 2. Confirm the output signals are in streaming output. 3. Confirm whether the camera resolution can be used together with the monitor equipment. 4. Replace the cables and make sure they are not faulty.
3.	Camera image is severely delayed	Please use 1080p or 720p 60/50 fps rather than 25/30 fps signals.
4.	RS-232 cannot be controlled	<ol style="list-style-type: none"> 1. Confirm the connection is correct (RS-232 In/Out). 2. Please make sure the Baud rate setting is the same as the control equipment.
5.	Whether the internet can be used for operation	Please refer to Chapter 5 Network Function Setting . Description for the internet usage
6.	The ONVIF software cannot find the machine	Please make sure that [Setting] > [Video] > [Camera ID] / [Location] in the web page uses only English letters or numbers. The ONVIF software cannot find the machine if you use special characters and space.
7.	Tally lamp is not working when applying RS232 setting	Please make sure if the Tally lamp function is enabled from the setting menu or web page. Setting Menu: [System] > [Tally Lamp]
8.	The camera does not save the relevant parameters (PTZ, AWB ...) after reboot	Please make sure if the Initial Position is set to Last Operated Position from the setting menu or web page Setting Menu: [System] > [Initial Position]
9.	When tracking, the person moves out of the frame and is lost	<ul style="list-style-type: none"> ■ Confirm that the person tracking is set to half body or full body tracking. Because the number of samples for half body tracking is small, the full body tracking is more accurate than the half body tracking. ■ Walking speed may affect the tracking performance. The normal walking speed has better tracking performance. Make sure if the walking speed is too fast to be tracked.
10.	How to log in the portal when you forget your account password	Please contact your Marshall distributor or service center.
11.	The tracking person suddenly squats down and the camera stops tracking	When the person squats down and stands up again, there is a chance that the camera will stop tracking. The lens will zoom out first, and then zoom in after recognizing the target. This is a normal behavior

CHAPTER 8: SAFETY INSTRUCTIONS

Always follow these safety instructions when setting up and using this product:

- 1 Operation**
 - 1.1 Please use the product in the recommended operating environment, away from water, excessive heat or humidity.
 - 1.2 Do not place the product on a tilted or unstable trolley, stand or table.
 - 1.3 Please clean the dust on the power plug prior to usage. Do not insert the product's power plug into a multiplug to prevent sparks or a fire.
 - 1.4 Do not block the slots and openings in the case of the product. They provide ventilation and prevent the product from overheating.
 - 1.5 Do not open or remove covers, otherwise it may expose you to dangerous voltages and other hazards. Refer all servicing to licensed service personnel.
 - 1.6 Unplug the product from the wall outlet and refer servicing to licensed service personnel when the following situations happen:
 - If the power cords are damaged or frayed.
 - If liquid is spilled into the product or the product has been exposed to rain or water.
- 2 Installation**
 - 2.1 For security considerations, please make sure the standard mount you use is in line with UL or CE safety approvals and installed by technician personnel approved by agents.
- 3 Storage**
 - 3.1 Do not place the product power cord where it can be stepped on as this may result damage to the lead or the plug.
 - 3.2 Unplug this product during thunderstorms or if it is not going to be used for an extended period.
 - 3.3 Do not place this product or accessories on top of vibrating equipment or heated objects.
- 4 Cleaning**
 - 4.1 Disconnect all the cables prior to cleaning and wipe the surface with a dry cloth. Do not use alcohol or volatile solvents for cleaning.
- 5 Batteries (for products or accessories with batteries)**
 - 5.1 When replacing batteries, please only use similar or the same type of batteries.
 - 5.2 When disposing of batteries or products, please adhere to the relevant instructions in your country or region for disposing of batteries or products.

■ Precautions

	This symbol indicates that this equipment may contain dangerous voltage which could cause electric shock. Do not remove the cover (or back). No user-serviceable parts inside. Refer servicing to licensed service personnel.		This symbol indicates that there are important operating and maintenance instructions in this User Manual with this unit.
---	---	---	---

■ FCC Warning

This equipment has been tested and found to comply with the limits for a Class A digital device, pursuant to part 15 of the FCC Rules. These limits are designed to provide reasonable protection against harmful interference when the equipment is operated in a commercial environment.

Notice :

The changes or modifications not expressly approved by the party responsible for compliance could void the user's authority to operate the equipment..

This equipment has been tested and found to comply with the limits for a Class A digital device, pursuant to part 15 of the FCC Rules. These limits are designed to provide reasonable protection against harmful interference when the equipment is operated in a commercial environment.

■ IC Warning

This digital apparatus does not exceed the Class A limits for radio noise emissions from digital apparatus as set out in the interference-causing equipment standard entitled "Digital Apparatus," ICES-003 of Industry Canada.

Cet appareil numérique respecte les limites de bruits radioélectriques applicables aux appareils numériques de Classe A prescrites dans la norme sur le matériel brouilleur: "Appareils Numériques," NMB-003 édictée par l'Industrie.

■ EN55032 CE Warning

Operation of this equipment in a residential environment could cause radio interference. Warning: Operation of this equipment in a residential environment may cause radio interference

Warranty

Marshall Electronics warrants to the first consumer that this device will, under normal use, be free from defects in workmanship and materials, when received in its original container, for a period of two years from the purchase date. This warranty is extended to the first consumer only, and proof of purchase is necessary to honor the warranty. If there is no proof of purchase provided with a warranty claim, Marshall Electronics reserves the right not to honor the warranty set forth above. Therefore, labor and parts may be charged to the consumer. This warranty does not apply to the product exterior or cosmetics. Misuse, abnormal handling, alterations or modifications in design or construction void this warranty. No sales personnel of the seller or any other person is authorized to make any warranties other than those described above, or to extend the duration of any warranties on behalf of Marshall Electronics, beyond the time period described above.

Due to constant effort to improve products and product features, specifications may change without notice.

Marshall

20608 Madrona Avenue, Torrance, CA 90503

Tel: (800) 800-6608 / (310) 333-0606 • Fax: 310-333-0688

www.marshall-usa.com

support@marshall-usa.com