



User Manual

ATLONA

3G/HD/SD-SDI SIGNAL GENERATOR
SUPPORTS UP TO 1080P
AT-3GSDI500



TABLE OF CONTENTS

1. INTRODUCTION	3
2. FEATURES	3
3. PACKAGE CONTENTS	4
4. SPECIFICATIONS	5
5. FUNCTION MENU	6
5.1. Format	6
5.2. Video	6
5.3. Audio	6
5.4. Motion	6
5.5. ANC Data	6
5.6. System	6
6. PANEL DESCRIPTION	7
6.1. Bird's View	7
6.2. Input Panel	7
6.3. Output Panel	8
6.4. Bottom Panel	8
7. EDID LEARNING	9
8. NOTICE	10
9. APPENDIX	11
9.1. Data Identification Word of Ancillary Data Packet	11
9.2. Built-in Video Patterns	11
10. ATLONA PRODUCT REGISTRATION	14
11. SAFETY INFORMATION	15
12. WARRANTY	16

INTRODUCTION:

Atlona Technologies AT-3GSDI500 3G/HD/SD-SDI Signal Generator is an advanced SDI signal generator with multi-format (3G/HD/SD) and multi-pattern support. Besides still and moving video test patterns, other features such as audio (SMPTE-291M) are also provided. AT-3GSDI500 can support up to 8 channel AES compliant audio with 48KHz sample rate. Another attractive feature of AT-3GSDI500 comes from bypassing HDMITH input and allows users with more testing patterns for connected display or treats AT-3GSDI500 as an advanced HDMITH to SDI converter with 3G capability. With portable size, AT-3GSDI500 is equipped four buttons and LCM screen to ease the control. This device provides a cost effective way to calibrate and test SDI enable video devices and displays.

FEATURES:

- Supported output video resolution
 - SD-SDI — NTSC 525 @60Hz, PAL 625 @50Hz
 - HD-SDI — 720p @50Hz, 59.94Hz, 60Hz
 - 1080i @50Hz, 59.94Hz, 60Hz
 - 1080p @23.98Hz, 24Hz, 25Hz, 29.97Hz, 30Hz
 - 3G-SDI — 1080p@50Hz, 59.94Hz, 60Hz
- Supported output audio format
 - SMPTE 291M, SMPTE 299M (8 channel audio, audio group can be adjusted)
- Bit rate
 - SD-SDI — 270Mbps
 - HD-SDI — 1.485Gbps, 1.4835Gbps
 - 3G-SDI — 2.97Gbps, 2.967Gbps
- Video Patterns
 - 100% Color Bars, Borderline, Random Noise, Check Field, Black, Vertical Lines, Black / White alternate fields, Full Grey / Full White, Black to White Gradient, Random Generator for all still patterns, moving squares White noise, Inverse effect with still pattern, Scrolling Title (see Appendix for illustrations)
- Supports HDMITH bypass mode
- Save settings to memory option
- ANC data
 - EDH (RP-165), SMPTE 352M, SMPTE291M
- Control
 - By LCM & Panel Buttons
- Video output
 - Dual 3G capable SDI output



PACKAGE CONTENTS:

- 1x AT-3GSDI500
- 1x 5V power supply unit
- 1x User's manual

SPECIFICATIONS:

Model Name	AT-3GSIDI500	
Technical		
Role of usage	Pattern generator	
SDI standards	3G / HD / SD-SDI	
Auto SDI rate detection	Yes	
Supported protocols	SMPTE 259M (270Mbps / 360Mbps) SMPTE 292M / HDTV (1.485 & 1.485/1.001Gbps) SMPTE 424M / 425M (2.97 & 2.97/1.001Gbps)	
Video bandwidth	2.97Gpbs	
Data rates	143 / 270 / 1483 / 1485 / 2967 / 2970 Mbps	
Video support	[3G] 1080p@50/59.94/60 (4:2:2) [HD] 720p50/59.94/60, 1080p24/30, 1080i50/59.94/60 [SD] NTSC@59.94Hz, PAL@50Hz	
SDI signal type	SMPTE-292M / 259M / 424M	
Pathological pattern (RP-198)	Immune	
HDMI TH bypass	Yes	
Output impedance	75Ω	
Cable (Belden 1694A) equalization / transmission	3G-SDI - up to 190ft (60m) HD-SDI - up to 500ft (150m) SD-SDI - up to 1000ft (300m)	
Audio support	Yes	
PCB Stack-up	4-layer board [impedance control — differential 100Ω; single 50Ω]	
Input	None	
Output	2x BNC [SDI]	
BNC connector	75Ω interlocking socket	
HDMI TH connector	Type A [19-pin female]	
[HD] Eye pattern characteristics	Amplitude: Within 800mV <10% Rise overshoot: Less than 2% Fall overshoot: Less than 2%	Long time jitter <1.0 UI Timing jitter <1.0 UI Alignment jitter <0.2 UI
Mechanical		
Housing	Metal enclosure	
Dimensions [L x W x H]	Model	6" x 4.7" x 1.3" (154 x 119 x 33mm)
	Package	7.7" x 12.8" x 3.6" (196 x 325 x 92mm)
Weight	Model	1.4 lbs (633g)
	Package	2.8 lbs (1260g)
Fixedness	Latch-locking power supply	
Power supply	5V 4A DC	
Power consumption	10 Watts [max]	
Operation temperature	32~104°F (0~40°C)	
Storage temperature	-4~140°F (-20~60°C)	
Relative humidity	20~90% RH [no condensation]	

The measurement results are from Tektronix WFM-7120 with SDI through 3.3ft (1m) long Belden 1694A.

FUNCTION MENU:

5.1. Format

- Resolution – NTSC / PAL / 720p / 1080p / 1080i
- Frequency – 60Hz / 59.94Hz / 50Hz / 30Hz / 29.97Hz / 25Hz / 24Hz / 23.98Hz
- Output – YCbCr 4:2:2

5.2. Video

- Patterns – SMPTE Bar / 100% Bar / Check Field / EQ / PLL
 Gradient R1 / Gradient G1 / Gradient B1
 Gradient R2 / Gradient G2 / Gradient B2
 Gradient R3 / Gradient G3 / Gradient B3
 Gradient R4 / Gradient G4 / Gradient B4
 Red Level 1 / Red Level 2
 Green Level 1 / Green Level 2
 Blue Level 1 / Blue Level 2
 100% Red / 100% Green / 100% Blue / White / Gray Level
 40% Gray / 70% Gray / Black / Noise
 Circle 1 / Circle 2 / Moire
 H Stripe R / H Stripe G / H Stripe B
 V Stripe R / V Stripe G / V Stripe B
 Chess 1 / Chess 2 / Sequence
- Text – Off / On-White / On-Black
- Timer – Off / On-W/B / On-B/W

5.3. Audio

- Mode – Off / On
- Group – 1+2 / 3+4
- Level – -6dB / -12dB / -18dB / -24dB / -30dB / -36dB / -42dB / Silence / Random
- Mask – Off / CH 1234 / CH 1 / CH 2 / CH 3 / CH 4 / CH 1+2 / CH 3+4

5.4. Motion

- Motion – No Motion / Square 1 / Square 2 / 2 Squares / Square Inv
- Data Speed – 1 / 2 / 3 / 4 / 5 / 6 / 7 / 8

5.5. ANC Data

- SMPTE-352M – Off / On
- EDH – On / Off

5.6. System

- Status – No Change / Factory / Now Save
- Version – V1.01

PANEL DESCRIPTION:

6.1. Bird's View

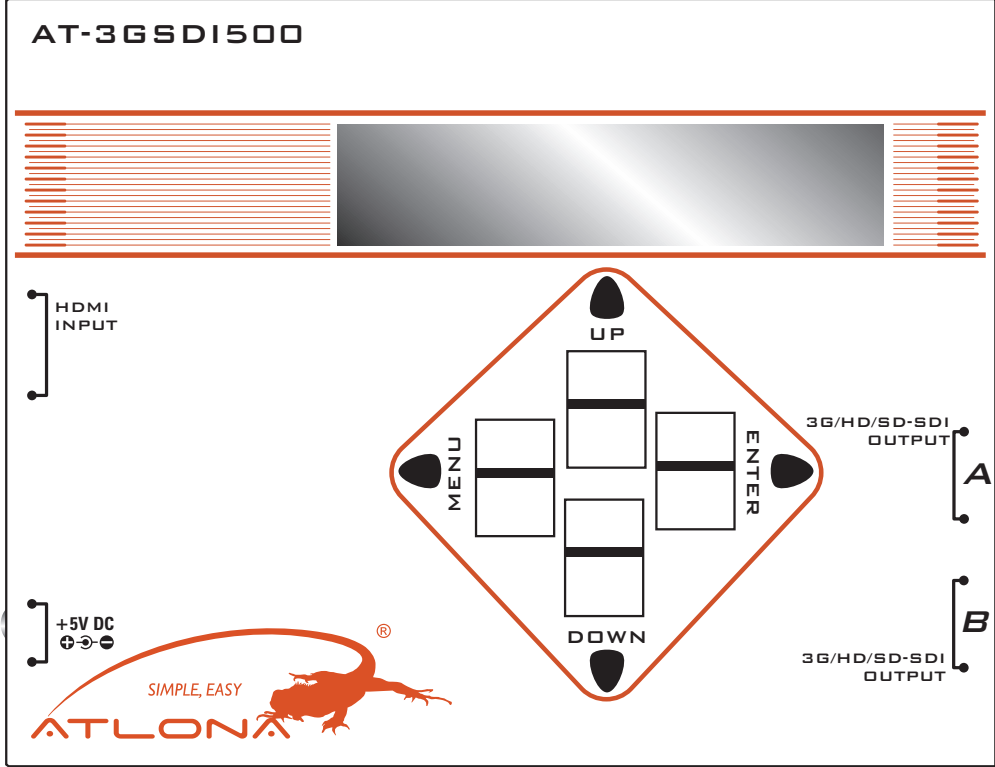

Button	Function
Menu	Trigger the function menu
Enter	Enter the menu item
Up	Choose the last menu item
Down	Choose the next menu item

6.2. Input Panel

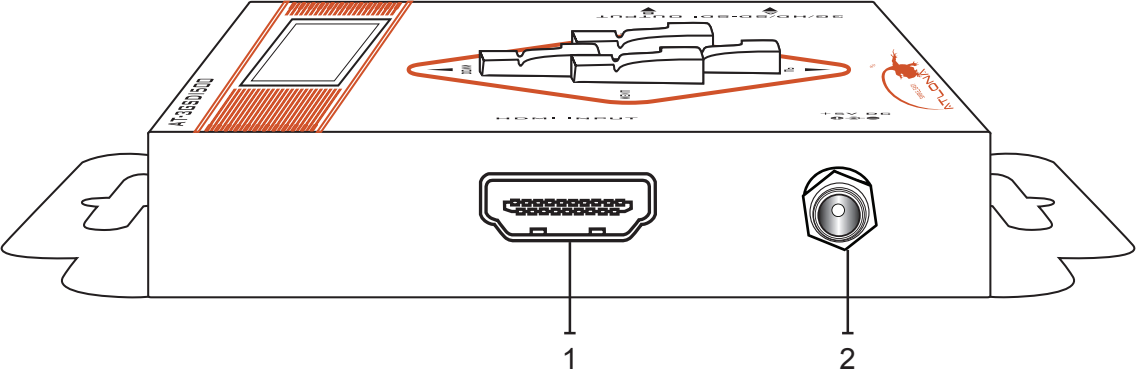

1. HDMITM INPUT: Plug in a HDMITM cable to be linked to a HDMITM source
2. +5V DC: Connect to a 5V DC power supply unit

6.3. Output Panel

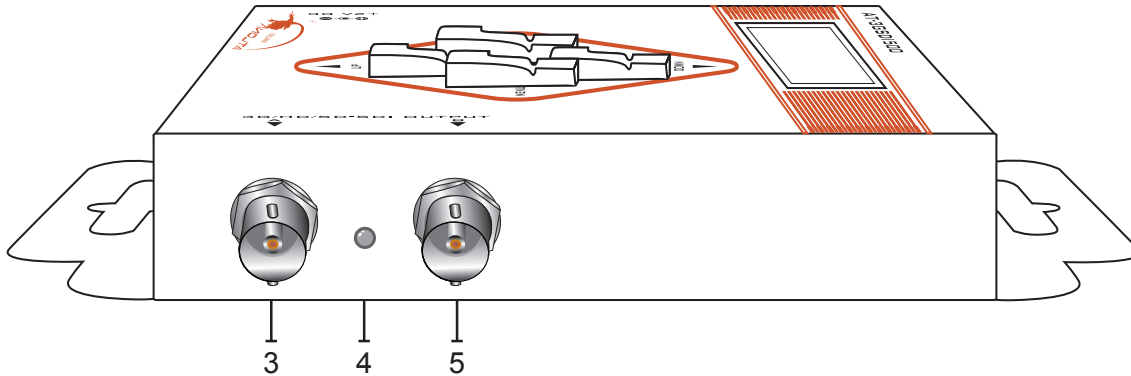

3. SDI OUTPUT A: Connect to a SDI device for SDI, HD-SDI, or 3G-SDI signal output either from the chosen pattern or the converted HDMITH source signal
4. Lock LED: showing if the audio/video signal existed or not
5. SDI OUTPUT B: Connect to a SDI device for SDI, HD-SDI, 3G-SDI signal output either from the chosen pattern or the converted HDMITH source signal

6.4. Bottom Panel



A 4-pin DIP switch is used for user interface, and users can access this switch from the bottom of the unit.

Pin No.	1	2	3	4
ON (↑)	Used for SMPTE352M	3G level B	10	Update EDID
OFF (↓)		3G level A	Not in use	Default EDID

1. Factory default for 4-pin DIP switch: OFF-OFF-OFF-OFF [↓-↓-↓-↓]
2. In order to keep the compatibility of HDMITH to most monitors, AT-3GSDI500 features EDID learning ability. The operation is shown in the EDID LEARNING section.

EDID LEARNING:

1. Power off AT-3GSDI500 and set the pin 4 of DIP switch of AT-3GSDI500 to OFF [↓].
2. Connect the HDTV to the HDMITH port on the AT-3GSDI500, and then power on AT-3GSDI500.
3. The Lock LED on the AT-3GSDI500 will dim and light again, which indicates the EDID learning process is done.
4. Connect AT-3GSDI500 to the HDMITH source through a HDMITH cable and enjoy the experience.

NOTICE:

1. In HDMI[™] bypass mode, users must be aware of that the jitters coming from HDMI[™] sources, such as DVD players, may be much higher than typical requirement according to SMPTE request on HD-SDI signals. This will result in SDI output with high jitters or even no SDI outputs!
2. Due to the high frequency bandwidth and low jitter requirement of 3G-SDI signals, for single SDI output case, it is strongly recommended to use one 75 ohm terminator for the unused SDI output to keep the best performance.

APPENDIX:

9.1. Data Identification Word of Ancillary Data Packet

ANC Data	DID	SDID / DBN
352M	0x41	0x01
RP-165-EDH*	0xF4	0x00

- Data Type 1(SMPTE-291M)

9.2. Built-in Video Patterns



SMPTE Bar



100% Bar



Check Field



EQ



PLL



Gradient R1



Gradient G1



Gradient B1



Gradient R2



Gradient G2



Gradient B2



Gradient R3



Gradient G3



Gradient B3



Gradient R4



Gradient G4



Gradient B4



Red Level 1



Red Level 2



Green Level 1



Green Level 2



Blue Level 1



Blue Level 2



100% Red



100% Green



100% Blue



Gray Level



40% Gray



70% Gray



Black

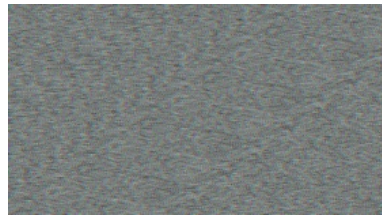

Noise

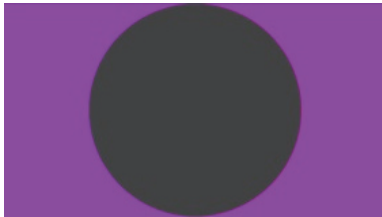

Circle 1



Circle 2

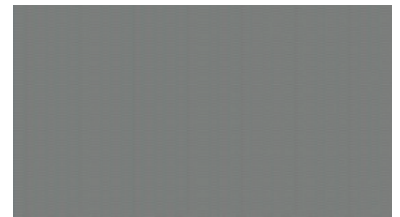

Moire

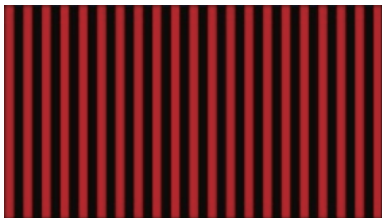

V Stripe R



V Stripe G

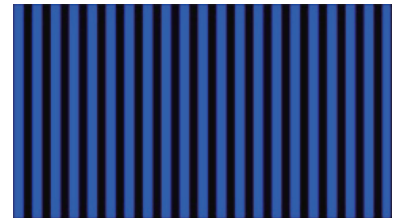

V Stripe B



H Stripe R



H Stripe G

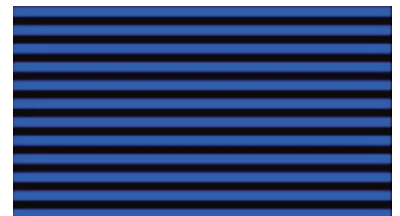

H Stripe B

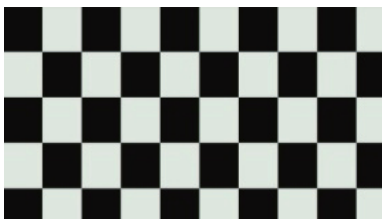

Chess 1

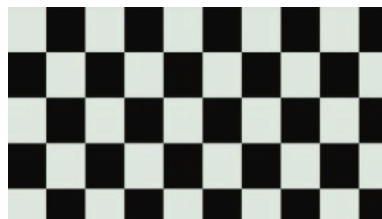

Chess 2

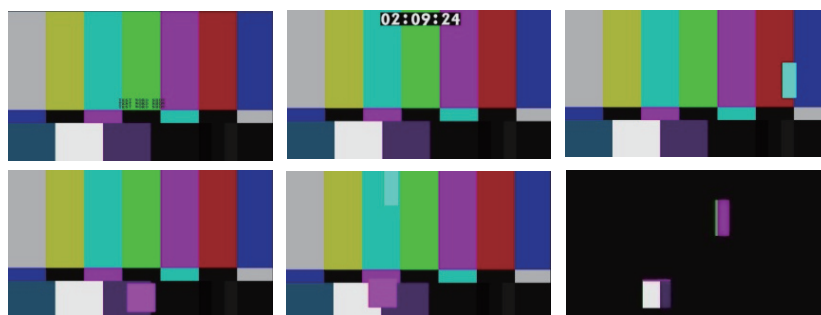

Sequence



ATLONA PRODUCT REGISTRATION:

Thank you for purchasing this Atlona product — we hope you'll enjoy it.

We also hope that you'll take a few moments to register your new purchase. Registration creates an ownership record if your product is lost or stolen and helps ensure you'll receive notification of performance issues and firmware updates. At Atlona, we respect and protect your privacy and assure you that your registration information is completely secure. Of course, Atlona product registration is totally voluntary and failure to register will not diminish your limited warranty rights.

To register go to www.atlona.com/registration

SAFETY INFORMATION:

Safeguards

To reduce the risk of electric shock, do not expose this product to rain or moisture.

If the wall plug does not fit into your local power socket, hire an electrician to replace your obsolete socket.

Do not modify the wall plug.

Doing so will void the warranty and safety features.

This equipment should be installed near the socket outlet and the device should be easily accessible in case it requires disconnection.

Precautions

FCC Regulations state that any unauthorized changes or modifications to this equipment not expressly approved by the manufacturer could void the user's authority to operate this equipment.

Operate this product using only the included external power supply. Use of other power supplies could impair performance, damage the product or cause fires.

In the event of an electrostatic discharge, this device may automatically turn off. If this occurs, unplug the device, and plug it back in.

Protect and route power cords so they will not be stepped on or pinched by anything placed on or against them. Be especially careful of plug-ins, or cord exit points from this product.

Avoid excessive humidity, sudden temperature changes or temperature extremes.

Keep this product away from wet locations such as bathtubs, sinks, laundries, wet basements and swimming pools.

Use only accessories recommended by ATLONA to avoid fire, shock or other hazards.

Unplug the product before cleaning. Use a damp cloth for cleaning. Do not use cleaning fluid or aerosols, which could enter the unit and cause damage, fire or electrical shock. Some substances may also mar the finish of the product.

Never open or remove unit panels or make any adjustments not described in this manual. Attempting to do so could expose you to dangerous electrical shock or other hazards. It may also cause damage to your AT-3GSDI500. Opening the product will void the warranty.

Do not attempt to service the unit. Instead disconnect it and contact your Authorized ATLONA reseller or contact ATLONA directly.

WARRANTY:

1. LIMITED WARRANTY

Atlona Technologies warrants that (a) its products (the "Product") will perform substantially in accordance with the accompanying written materials for a period of 3 years from the date of receipt and (b) that the Product will be free from defects in materials and workmanship under normal use and service for a period of 3 years. In the event applicable law imposes any implied warranties, the implied warranty period is limited to 3 years from the date of receipt. Some jurisdictions do not allow such limitations on duration of an implied warranty, so the above limitation may not apply to Customer.

2. CUSTOMER REMEDIES

Atlona Technologies and its suppliers' entire liability and Customer's exclusive remedy shall be, at Atlona Technologies' option, either return of the price paid for the Product, or repair or replacement of the Product that does not meet this Limited Warranty and which is returned to Atlona Technologies with a copy of Customer's receipt. This Limited Warranty is void if failure of the Product has resulted from accident, abuse, or misapplication. Any replacement Product will be warranted for the remainder of the original warranty period or 3 year, whichever is longer.

3. NO OTHER WARRANTIES

TO THE MAXIMUM EXTENT PERMITTED BY APPLICABLE LAW, ATLONA TECHNOLOGIES AND ITS SUPPLIERS DISCLAIM ALL OTHER WARRANTIES, EITHER EXPRESS OR IMPLIED, INCLUDING, BUT NOT LIMITED TO IMPLIED WARRANTIES OF MERCHANTABILITY AND FITNESS FOR A PARTICULAR PURPOSE, WITH REGARD TO THE PRODUCT AND ANY RELATED WRITTEN MATERIALS. THIS LIMITED WARRANTY GIVES CUSTOMER SPECIFIC LEGAL RIGHTS. CUSTOMER MAY HAVE OTHER RIGHTS DEPENDING ON THE JURISDICTION.

4. NO LIABILITY FOR DAMAGES

TO THE MAXIMUM EXTENT PERMITTED BY APPLICABLE LAW, IN NO EVENT SHALL ATLONA TECHNOLOGIES OR ITS SUPPLIERS BE LIABLE FOR ANY DAMAGES WHATSOEVER (INCLUDING WITHOUT LIMITATION, SPECIAL, INCIDENTAL, CONSEQUENTIAL, OR INDIRECT DAMAGES FOR PERSONAL INJURY, LOSS OF BUSINESS PROFITS, BUSINESS INTERRUPTION, LOSS OF BUSINESS INFORMATION, OR ANY OTHER PECUNIARY LOSS) ARISING OUT OF THE USE OF OR INABILITY TO USE THIS PRODUCT, EVEN IF ATLONA TECHNOLOGIES HAS BEEN ADVISED OF THE POSSIBILITY OF SUCH DAMAGES. IN ANY CASE, ATLONA TECHNOLOGIES' AND ITS SUPPLIERS' ENTIRE LIABILITY UNDER ANY PROVISION OF THIS AGREEMENT SHALL BE LIMITED TO THE AMOUNT ACTUALLY PAID BY YOU FOR THE PRODUCT. BECAUSE SOME JURISDICTIONS DO NOT ALLOW THE EXCLUSION OR LIMITATION OF LIABILITY FOR CONSEQUENTIAL OR INCIDENTAL DAMAGES, THE ABOVE LIMITATION MAY NOT APPLY TO YOU.