

USER MANUAL

AMPMA40X

40 Watt Mini Digital Amplifier with EQ/Mixer



IR Remote Control Model AMPIRMA40X

Table of Contents

1. Introduction	3
2. Features	3
3. Specification	4
4. Audio Connection.....	5
5. Buttons Control	8
6. RS232 Communication Protocol.....	10
7. System Diagram	12
8. Panel Drawing.....	13
9. AMPIRMA40X Instruction Sheet.....	13

1. Introduction

AMPMA40X is a compact-size digital amplifier (Class-D) with 3 inputs(2 line in and 1 balanced MIC). It is integrated with powerful functions, including bridge connection, dual-mono, EQ control, microphone mixer etc.

It has a good application in different places, including classroom, small meeting room, lecture hall, bar, pub etc.

2. Features

- Two stereo audio inputs, switchable by button, IR remote & RS232.
- Volume/Bass/Treble controllable by buttons IR remote & RS232.
- 2x20Watt@4Ohm as the default amplifier output.
- Line audio output at 3.5mm jack, with volume controllable.
- Bridge connection function. User can switch the AMPMA40X to be 1x40Watt@8Ohm by bridge connection.
- Dual-mono function. User can sum up the stereo audio to two times mono audio.
- MIC mixer function. The microphone will be mixed to the line audio output, and be controlled separately.
- MIC input supports 48V phantom power, dynamic MIC and wireless MIC.
- MIC port can support balance/unbalance signal, suppress the external noise effectively.
- Auto noise gate. It keeps detecting the audio and MIC input, will mute the output when there is no input.
- Ultra low inrush current, no need for power sequencing. This allows multiple AMPMA40X to be powered on simultaneously without overloading power circuits.
- Convection cooler, fan is not needed.
- Antistatic case design: providing good protection for long-term and stable performance
- LED indicator, for power and working status.
- IR Remote Control Model AMPIRMA40X available (sold separately)

3. Specification

Audio Input		Audio Output	
Input 1	1 ea. stereo audio (L & R RCA)	Output 1	1 ea. amplifier,
Input 2	1 ea. stereo audio (3.5 mini jack)	Output 2	1 ea. stereo audio
Input 3	1 ea. MIC		
Input Connector 1	2 ea. RCA L/R	Output Connector 1	1 ea. captive screw connector
Input Connector 2	1 ea. 3.5 mm jack stereo	Output Connector 2	1 ea. 3.5 mm jack (Stereo or Mono)
Input Connector 3 (Mic)	1 ea. captive screw connector,		
Input Impedance	>10K Ω	Output Impedance	50 Ω /stereo, 4~8 Ω /Amplifier
Audio General			
Frequency Response	20Hz ~ 20KHz	CMRR	>70dB@20Hz~20KHz
SNR	80dB at maximum output	Bandwidth	20Hz ~ 25KHz
Stereo Channel Separation	>75dB@20Hz to 20KHz	THD + Noise	1%@1KHz, 0.3%@20KHz at nominal level
Voltage Gain	32dB	Power Output	2x20 Watts (4 Ohms)
Control Function			
RS232 Control	Captive Screw Connector		
IR Remote	IR Remote Control		

Mini Digital Amplifier, with MIC Mixer and EQ

General			
Max DC Compensation	1.5V	Humidity	10% ~ 90%
Temperature	-20°C ~ +70°C	Power Consumption	24VDC, 3A
Power Supply	100VAC ~ 240VAC, 50/60Hz	Product Weight	0.5Kg
Case Dimension	4 7/8" W x 3 7/16" L x 1.5" D(H) 123mm W x 87mm L x 38mm D(H) (Wall/Table mountable)		

NOTE: All nominal levels are at $\pm 10\%$.

4. Audio Connection

4.1 Audio Output

4.1.1 Default output: 2x20Watt@40hm

The default output of amplifier is 2x20Watt@40hm, so user can connect the amplifier output in the regular way. As the picture below:

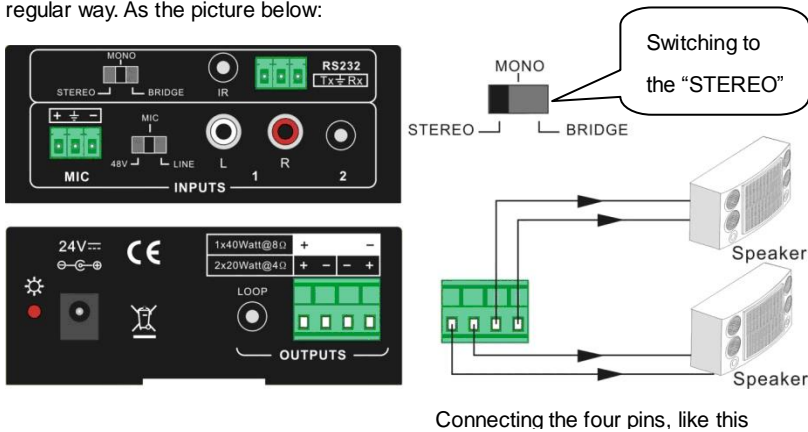

Connecting the four pins, like this

4.1.2 Bridge connection: 1x40Watt@80hm

The AMPMA40X has the bridge connection, to double the output power at 1x40Watt@80hm. It will sum up the input left channel and input right channel to be mono output, and the power is up to 40Watt.

The bridge connection is:

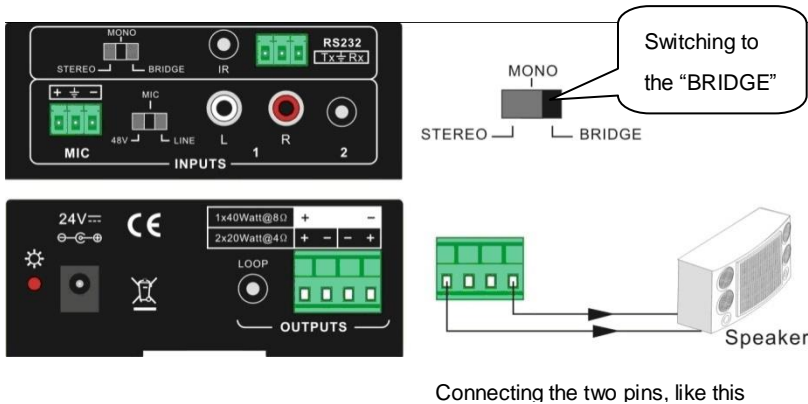

Connecting the two pins, like this

Mini Digital Amplifier, with MIC Mixer and EQ

4.1.3 Dual-mono output:

The AMPMA40X also has the function of double-mono output. It can sum up the left and right channel, to be the mono audio output. In this way, the both of the outputs are showing the same mono audio.

The connection is:

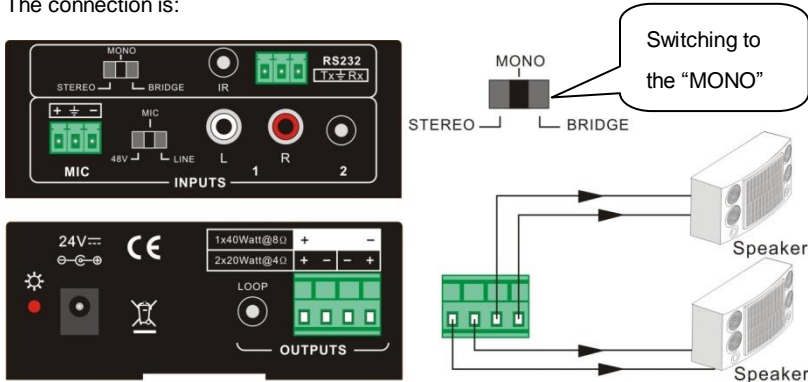

Connecting the four pins, like this

4.2 Microphone input

The microphone input of AMPMA40X has three modes, and different modes use different connections, as the picture below:

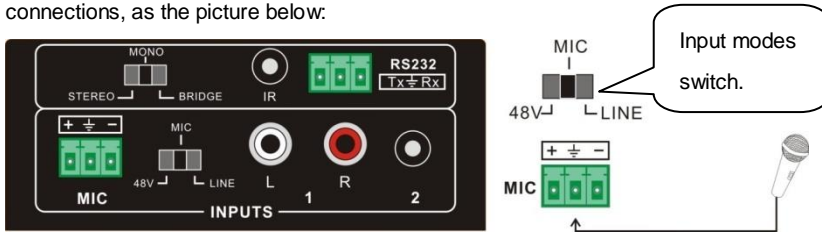

4.2.1 48V phantom power input

When the switch turns to “48V”, the MIC input will provide a 48V phantom power. This is usually used for power supply for condenser microphone, Connection is:

“+” connects to positive, “-” connects to negative and “⊥” to ground.

NOTICE: In this mode, only condenser microphone can be connected with.

4.2.2 MIC input

When the switch turns to “MIC”, the microphone input is used for connecting with dynamic microphone. There are two different connections:

- 1) Unbalanced connection:

Mini Digital Amplifier, with MIC Mixer and EQ

- a) “ \perp ” connects to ground, and “-” connects to signal.
 - b) “ \perp ” connects to ground, and “+” connects to signal.
- 2) Balanced connection: “+” connects to positive, “-” connects to negative and “ \perp ” connects to ground.

4.2.3 LINE input

When the switch turns to “LINE”, the microphone input is used for connecting with normal audio or wireless microphone output. There are two different connections:

- 1) Unbalanced connection:
 - a) “ \perp ” connects to ground, and “-” connects to signal.
 - b) “ \perp ” connects to ground, and “+” connects to signal.
- 2) Balanced connection: “+” connects to positive, “-” connects to negative and “ \perp ” connects to ground.

5. Buttons Control

The buttons provides the control of volume/EQ control and switching.

5.1 Audio switching

There are two switchable stereo audio inputs, one 2xRCA input, and one 3.5mm jack input, switchable through the buttons as below:

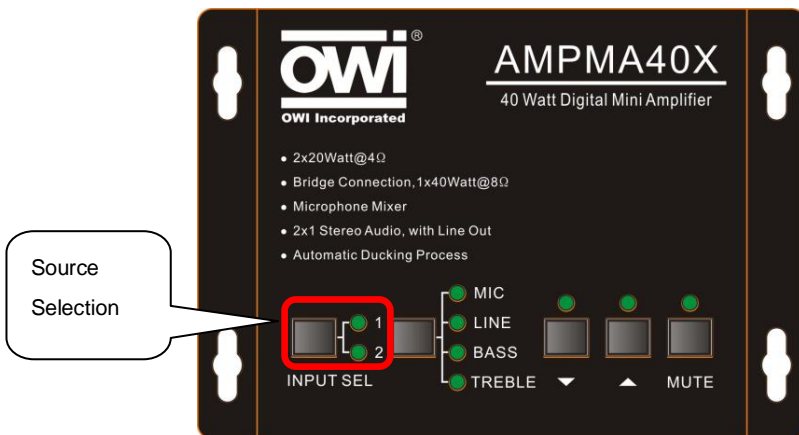

Mini Digital Amplifier, with MIC Mixer and EQ

5.2 Volume/EQ controlling

The line volume and MIC volume can be controlled by the buttons.

The MIC Volume/LINE volume/LINE bass/LINE treble will be selected by the buttons, and controlled up/down/mute by the function buttons. Please check the picture below:

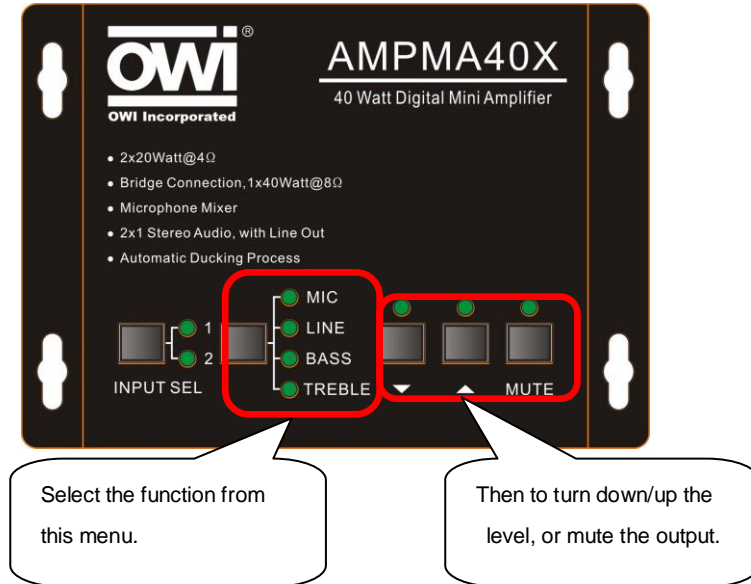

For example, to turn up the line volume, you should select the “LINE” first, and then press the button “ ”. ▲

6. RS232 Communication Protocol:

Baud rate: 9600

Data bit: 8

Stop bit: 1

Parity bit: none

Command	Function Description	Feedback Code
1A1.	Switching the audio to input 1	A: 1 -> 1
2A1.	Switching the audio to input 2	A: 2 -> 1
0A0.	Mute Audio of MIC and Line out	Mute Audio
1A0.	Mute audio of MIC	Mute MIC
2A0.	Mute audio of line out	Mute LIN
0A1.	Unmute Audio	Unmute Audio
600%	Checking the working status	A: 1 -> 1 Volume: 30 Bass: 00 Treble: 00
601%	MIC volume up	Volume of MIC: 51
602%	MIC volume down	Volume of MIC: 51
603%	Line volume up	Volume of LINE: 51
604%	Line volume down	Volume of LINE: 51
605%	Bass level up	Bass of LINE: 04
606%	Bass level down	Bass of LINE: 04
607%	Treble level up	Treble of LINE: 04
608%	Treble level down	Treble of LINE: 04
609%	Initialization, back to the default setting	A: 1 -> 1 Volume: 50 Bass: 04 Treble: 04

Mini Digital Amplifier, with MIC Mixer and EQ

Command	Function Description	Feedback Code
5[x][x]%	Preset MIC volume, [xx] arranges from [00] to [60]. 61 degrees in total.	Volume of MIC: 50
7[x][x]%	Preset line volume, [xx] arranges from [00] to [60]. 61 degrees in total.	Volume of LINE: 50
8[x][x]%	Preset the bass level, [xx] arranges from [00] to [08]. 9 degrees in total.	Bass of LINE: 04
9[x][x]%	Preset the treble level, [xx] arranges from [00] to [08]. 9 degrees in total.	Treble of LINE: 04

Notice:

- 1: The letter inside bracket [] is the variable code, which is the changeable.
- 2: The bracket [] is not included to the RS232 commands.
- 3: Any dot "." after the letters is part of the commands.

Example 1:

Switching the input 2 to the line out. We should send the RS232 command: **[2A1.]**

Example 2:

Turning up the volume of line audio. We should send the RS232 command: **[603%]**

Example 3:

Preset the MIC volume to "21" degree. We should send the RS232 command: **[521%]**

Example 4:

Checking the working status of AMPMA40X. We should send the RS232 command: **[600%]**

7. System Diagram

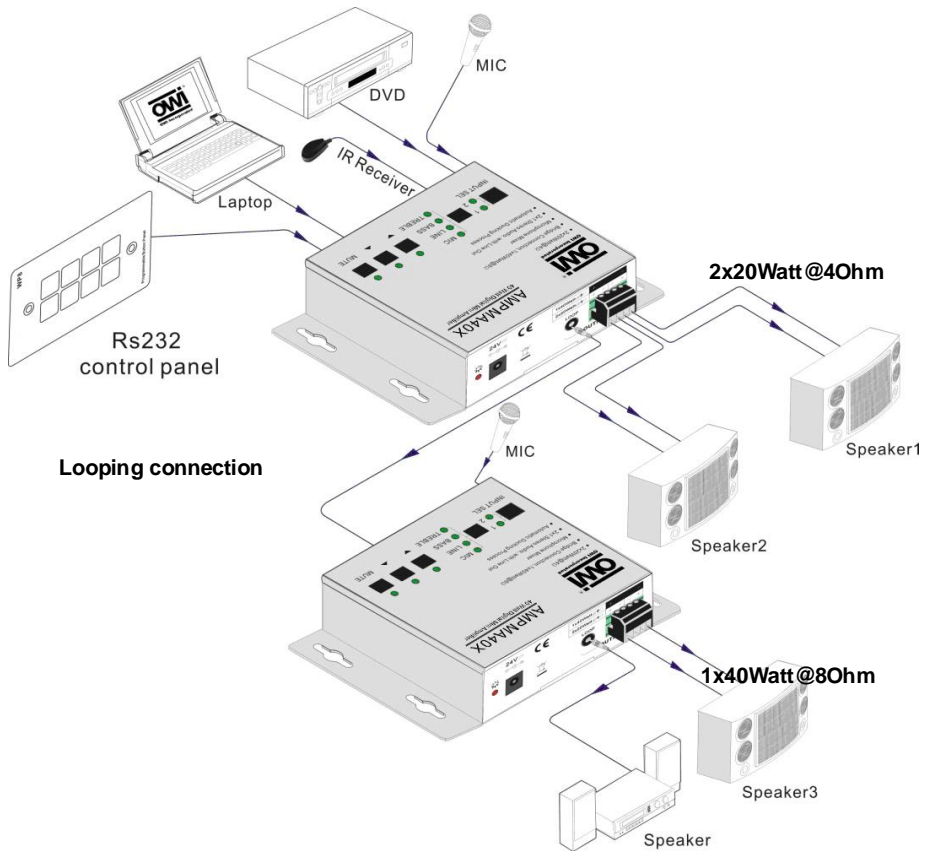

8. Panel Drawing

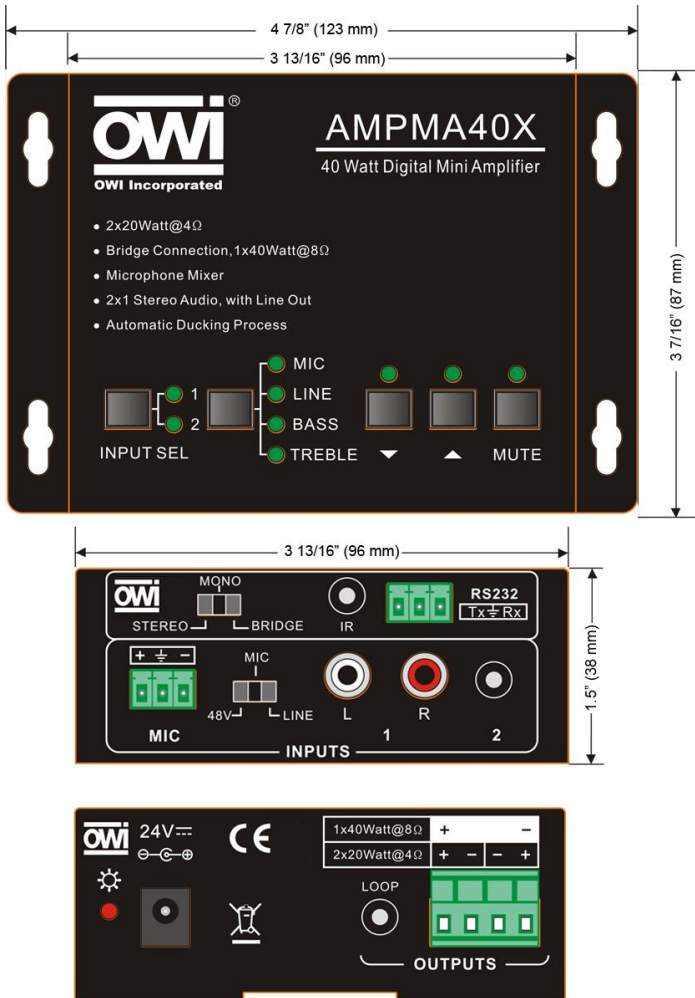

Unit: inches (mm)

9. Remote Control AMPIRMA40X

Remote Control with Sensor for the Digital Amplifier AMPMA40X

The AMPMA40X has an IR control function that works with the “AMPIRMA40X” package (IR receiver and IR remote).



IR REMOTE

The IR remote has built in popular functions like Input Channels Selection, Mute and Volume/EQ control.

The function description is shown below:

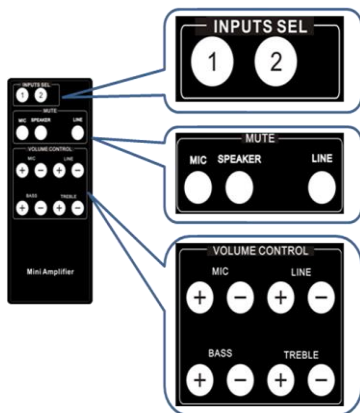

- Input channel selection:
- 2x1 selection.
- Mute selection:
The user can mute the whole volume out, MIC volume or line volume separately.
- Volume/EQ control:
The user can control the level up/down of line volume, Microphone volume, Bass/Treble.

The IR remote is powered by a lithium battery, model name CR2025. (Battery not included). It is 2" wide x 4 ^{7/8}" long x 3/8" thick.

Mini Digital Amplifier, with MIC Mixer and EQ

IR RECEIVER

The IR receiver is used to receive the IR code from the remote controller. It connects to the AMPMA40X by 3.5mm jack connector, and receives the IR code by the IR sensor. The IR sensor has an adhesive tape at the back that can be stick on the wall or ceiling. The IR receiver is about 4' 9" in length (Please see the illustration below).

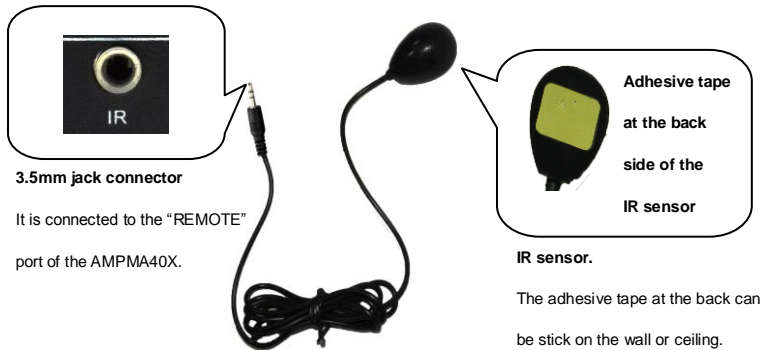

Connection:

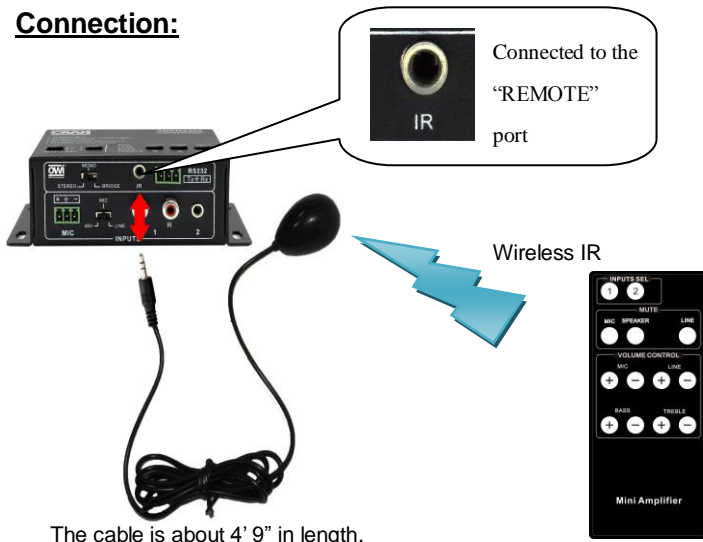

The cable is about 4' 9" in length.

Remarks: For any questions or problems, please try to get help from your local distributor, or call OWI at 310-515-1900 or email info@owi-inc.com

WARRANTY

OWI INCORPORATED
17141 Kingsview Ave
Carson, CA 90746

Date Purchased: _____

Model Number: _____

(Keep this part for your record)

----- CUT AND MAIL -----



OWI INCORPORATED
17141 Kingsview Ave
Carson, CA 90746

LIMITED THREE YEAR WARRANTY

Model Number: _____

Model Name: _____

Serial No. _____

Date of Purchase: Month: _____ Day _____ Year _____

Owner's Name: _____

Address: _____ City: _____ State _____ Zip _____

Dealer's Name: _____ City _____ State _____

Purchased from (please check one):

Video , Electronic , Mail Order , Mass Merchandiser , Installer

Others (please specify) _____

Remarks: _____
