

rocsecure®

secure your future



COMMANDER 3F series
User Manual

TABLE OF CONTENTS

| | |
|--|-----------|
| IMPORTANT NOTICES | 4 |
| • Safety Notices | 4 |
| • General Notices | |
| • Capacity Disclaimer | 4 |
| • Care and Handling | 4 |
| GENERAL | 6 |
| • Introduction | 6 |
| • Box Contents | 8 |
| • Minimum System Requirements | 9 |
| • Connectors and Commander rear view | 9 |
| MUST BE READ FIRST | 10 |
| QUICK INSTALLATION | 12 |
| • How to Connect the Interface Cables - Connecting the Drive | 12 |
| • Cable Types: FireWire 800, FireWire 400, USB and SATA | 13 |
| INSTALLING YOUR DRIVE | 15 |
| • Commander as a bootable device | 15 |
| • Disconnecting Your Drive | 15 |
| ○ PC | 15 |
| ○ Mac | 16 |
| • Reformatting Your Drive | 16 |
| ○ Reformatting via PC (Window based computers) | 16 |
| ○ Reformatting via Mac | 16 |
| • Important Note | 16 |
| • How to Daisy-Chain through FireWire ports to your Commander Drive at one time | 17 |
| PARTITIONING AND FORMATTING THE COMMANDER DRIVE ON A MAC OS | 17 |
| • Warning | 17 |
| • Important Notes | 17 |
| • Instructions for Partitioning and Formatting from FAT 32 to HFS+ | 18 |
| PARTITIONING & FORMATTING the COMMANDER on WINDOWS 2000, XP, VISTA, 7 | 27 |
| • Warning | 27 |
| • Important Notes | 27 |
| • Different ways to get to the Control Panel | 28 |
| • Instructions upon reaching the Control Panel | 30 |

| | |
|--|-----------|
| • Instructions for Partitioning and Formatting from FAT 32 to NTFS _____ | 31 |
| TROUBLESHOOTING | 37 |
| • Troubleshooting for Macintosh computers _____ | 37 |
| • Troubleshooting for PC Windows based computers _____ | 39 |
| KNOWLEDGE BASE | 41 |
| • Commander HX Unique Features _____ | 42 |
| • Specifications | |
| • Encryption Technology (Q&A) _____ | 43 |
| • Introduction to Interfaces (ports) and Cables _____ | 48 |
| ○ USB (Universal Serial Bus) _____ | 50 |
| ○ SATA (Serial Advanced Technology Attachment) _____ | --- |
| ○ Comparison Chart _____ | 51 |
| • Introduction to Formatting _____ | 52 |
| ○ File Allocation Table (FAT) and FAT 32 _____ | 52 |
| ○ HFS Plus or HFS+ _____ | 53 |
| LIMITED WARRANTY | 54 |
| TECHNICAL SUPPORT | 58 |
| ACKNOWLEDGEMENTS | 58 |
| • Trademarks _____ | 58 |
| • Copyrights _____ | 58 |
| CONTACT INFORMATION | 59 |
| • Corporate Headquarters _____ | 59 |
| • Technical Support / Return Authorization “RMA” _____ | 59 |
| • Sales Info _____ | 59 |

IMPORTANT NOTICES

Safety Notices

- The warranty is void if an unauthorized person attempts and/or repairs the hard disk drive.
- Read all Manuals and instructions carefully before using the device.
- Do not spill any liquid or insert any object into the device.
- Use the device within the specifications indicated, including but not limited to: power requirements, temperature, humidity, sunlight and magnetism from other devices such as computers and televisions.
- Please visit the Rocstor website, www.rocstor.com for further information concerning specifications and use of the device.

General Notices

- Consistently make multiple backup copies of your data for your protection. Hard disk drives are subject to failure at any time.
- Rocstorage, Inc. shall not be held liable for loss of data or the restoration or recovery of data on the device. Please view complete Limited Warranty Information in this manual or on the Rocstor website (www.rocstor.com) for further details.

Capacity Disclaimer

Actual accessible hard drive capacity will indicate up to 10% lower than stated under different Operating Systems and formatting.

The storage volume is measured in total bytes before formatting. References to round numbers of gigabytes or terabytes are an approximation only. For example, a disk drive labeled as having 500GB (gigabytes) has space for approximately 500,000,000,000 bytes before formatting. After formatting, the drive capacity is reduced by about 5% to 10% depending on the operating system and formatting used.

Care and Handling

The following instructions concern the proper care and handling of Commander 3F Drives. Please take a moment to review these instructions.

- As with any storage solution, it is recommended that all data be backed up regularly.
- Ensure that you follow the proper removal procedure to disconnect the Commander drive.
- Do not move or disconnect this device from your computer while it is reading or writing data. This may cause damage to the Commander drive.
- Do not place this device near a heat source or expose it to direct flame.
- Do not place the device near any equipment generating strong electromagnetic fields. Exposure to strong electromagnetic fields may cause the device to malfunction or data to be corrupted.
- Do not drop or cause shock to your Commander drive.

- Do not spill any liquid or insert any object into the device.
- Do not attempt to disassemble and service the Commander drive during the warranty period.
- Please read the Safety Notices and Limited Warranty information in this Manual and on the Rocstor website (www.rocstor.com) for further details.



GENERAL

Introduction

COMMANDER F Series (Desktop) Encryption
FireWire 800 (400) and USB 3.0 (2.0)

Commander line has the world's most technologically advanced encrypted desktop external hard drive in the market today.

Commander 3F is made with more than 1.5 Lb (~0.75 Kg) of recycled aluminum, making this enclosure extremely ruggedized. The exclusive shock-absorbent mechanism (patent pending) within the enclosure keeps the hard drive suspended within the casing, while dissipating the heat produced by the hard drive, keeping it at the ideal temperature.



The built-in power supply will offer the user the flexibility they require by eliminating carrying extra non-standardized and sometimes bulky adaptors and cables. The power supply contained in the Commander line is Auto-Switchable 240VA/100VA (will work internationally) and uses any standard computer cable, no matter what country you are in. Commander contains no fan, making this device the quietest desktop external hard drive.

Commander external hard drives deliver extraordinary performance, transfer speeds, and reliability for both Mac and PC users. Specifically designed for demanding security concerned professionals, the Commander 3F contains a fast SATA high-capacity 3.5" drive in a stylish and unique aluminum case that can be stacked or mounted vertically. With its built-in power supply and fan-less and quiet operation, the Commander 3F can be easily moved from one desktop environment to another using the provided carrying case, with 4TB single hard drive introduction making this device the most versatile portable drive in the world today.

Commander F has been integrated with one of the most secure encryption hardware-based chipsets in the world. It contains **Advanced Encryption Standard Algorithm AES-256** bit key strength, real-time encryption. There is virtually zero time in encrypting and decrypting the data. In either CBC or ECB modes, the encryption chip bears certifications of the **National Institute of Standards and Technology (NIST)**, and **FIPS Level 2** for Cryptographic Module. It is authenticated by digital key token, which is inserted for authentication and removed soon after the device is authenticated and ready for use.



Choose Rocsecure drives and store your future.



Box Contents

- External hard disk drive
- Stand for vertical mounting
- USB cable (USB 3.0 to USB 3.0 or USB 3.0 to USB 2.0)
- 9-pin to 9-pin FireWire 800 (1394b) cable
- AC power cord
- Three (digital) key tokens
- Installation user Guide
- Carrying case



COMMANDER



FireWire 800
(9 to 9 pin) Cable



USB 3 Cable



Key Token (x3)



Power Cord



Stand



Carrying Case



Quick Installation
Guide

Minimum System Requirements

Mac Users:

Hardware: FireWire 800* (Or 400**) or USB 3.0 (2.0) port(s.)

Mac: PowerPC or Intel processor running Mac OS 9, X, Leopard, Snow Leopard, Lion

Recommended memory: 512 MB RAM

Window Users:

Hardware: FireWire 800* (Or 400**) or USB 3.0 (2.0) port(s.)

Operating Systems: Microsoft Windows 2000, Me, XP, Vista, Windows 7

Recommended memory: 512 MB RAM

**You may also connect Commander F series to a computer with FireWire 400; in this case you need a special cable or an adaptor from a 9 pin FireWire 800 connector of the Commander F to the 6Pin connector of FireWire 400.

Connectors

- FireWire 800 (IEEE 1394b) port x2
(You may connect FireWire 800 to a FireWire 400 port via a special cable {also read page 12})
- Standard AC power input connection
- Digital key token
- ON/OFF power switch
- USB 3.0 port x1

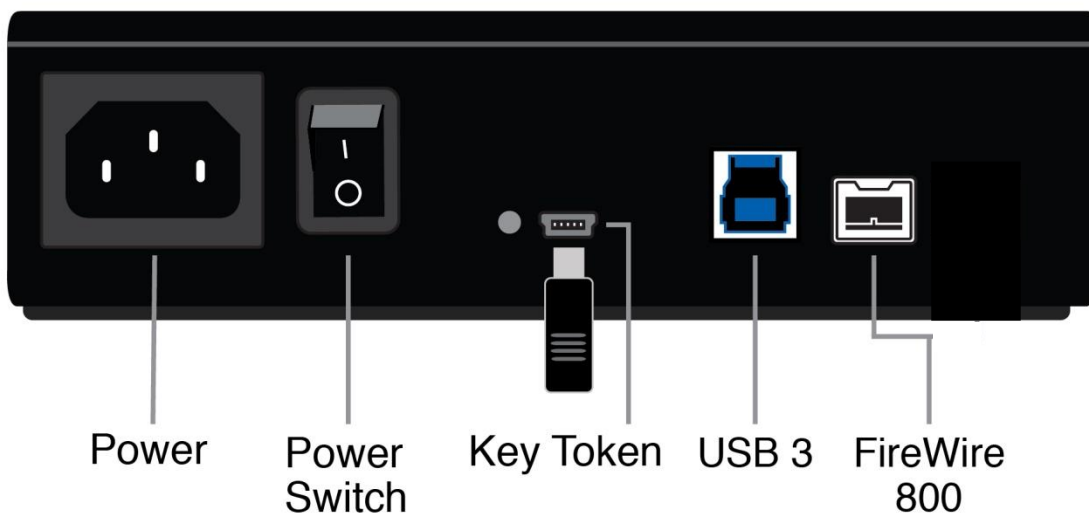

MUST BE READ FIRST

Commander 3F9 uses the most advanced encryption chip. It encrypts and decrypts all the data that is being read and written simultaneously in real-time. It uses a digital key token to authenticate and authorize to access data in the device.

This device contains three (3) digital key tokens that bear the mini USB form factor; the three (3) digital keys provided with each device are unique and have the same key codes.

- Each Commander works *only* with the similar digital key tokens that it has been formatted with.
- You must keep at least one of the digital key tokens in a safe place.
- **If you lose all of your digital key tokens, you lose your data.**
- Rocstor does not keep a note of any key codes nor will be able to copy any digital Keys.
 - In the future, you may order your device with as many keys with similar key codes as you prefer (extra digital keys bear additional costs). Rocstor is not able to reproduce or copy digital keys once it leaves the factory.
- Any set of digital keys can be formatted with as many Commander Products as you prefer. That means if you have two (2) or more (or even twenty [20]) Commander Devices you can format all of them with *one* set of digital keys. Digital key(s) with the same key code in this scenario are one set of keys that would authenticate all of the Commander devices.
- The key token works with the hard drive. If at any time if your device ports becomes defective but your hard drive is in working condition (not damaged), the hard drive can be instead into another similar enclosure and it will operate with your digital key that it had been formatted with originally.

If you lose one or even two digital keys, you may conduct the following tasks:

- Purchase another set of digital keys from Rocstor.
- You may purchase as many digital key tokens with the same key codes as you prefer (recommendation: not to exceed 11 pieces of digital keys with the same key codes).
- Once you have the new set of digital key tokens in your possession, you may proceed with the following tasks:
 - Using one of the original keys (may be the last key in your possession) that authenticates your drive, back up your data into another external hard drive or into a specific file made in your computer hard drive designated for these data transfer.

- Once completed, please check and be certain that the data you need is fully transferred; these data if not encrypted are vulnerable at this time.
- You are now ready to reformat the drive with the new set of digital keys that you received.

NOTE: By reformatting the Commander device now, you will lose all the data that you have stored in it. However, you had just transferred the data contained into a new temporary device.

- Insert the new set of digital key tokens you received into the Commander external drive and proceed with formatting. Once the key is inserted, the device operation is similar to any standard external hard drive; therefore, the formatting either for PC under Windows or Mac is the same. (If you seek help in formatting, please proceed with the formatting chapter in this manual; you may start with the Table of Contents on page two (2) of this manual. If you require live assistance, you may call Rocstor tech support toll-free at 888-877-7716, Ext 8883, or email support@Rocstor.com.)

Once the drive is formatted with a new digital key, which you received/purchased, it will authenticate the Commander device with that key (set of new keys) only. You may dispose of your previous leftover original digital keys.

You are now ready to transfer (“move”) back the data you had transferred to your computer or from another external hard drive to the newly formatted Commander 3F. And be sure to remove/delete the unsecure data that was left in your computer or the external hard drive if you desire.

QUICK INSTALLATION

How to Connect the Interface Cables - Connecting the Drive

1. Turn ON your computer and wait until it fully boots up to load all programs.

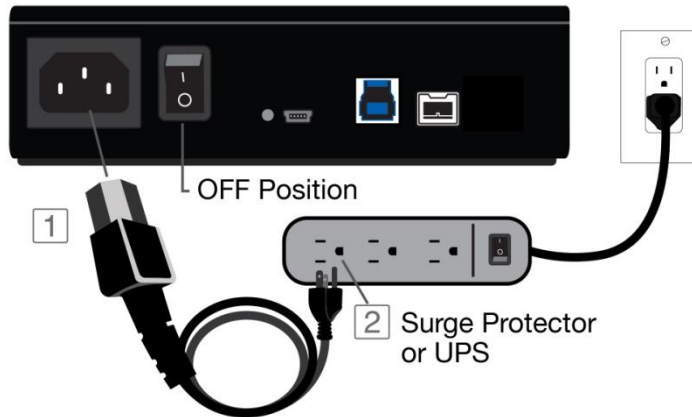

2. Insert one of the digital key-tokens into the designated port
3. Connect one end of the power cord directly to the Commander 3F and the other end to an AC outlet, surge protector or battery Backup (UPS).
4. Using only one interface cable at a time, select the interface port you wish to use on your computer. Connect one end of the cable to the Commander 3F and the other end to the computer. Please review cable types on the next page:

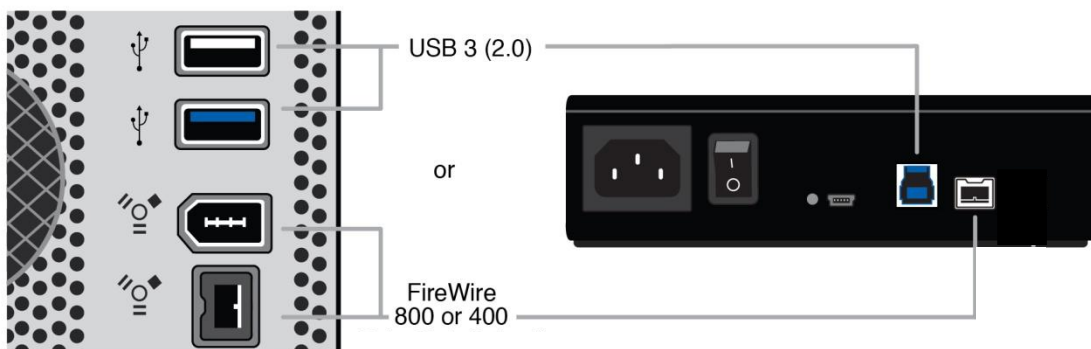

5. Turn the Commander 3F Hard Drive switch ON.

6. The Hard drive is preformatted for Plug-and-Play operation. After a few seconds a Rocstor HD icon will show on the “My Computer” folder under the Windows OS. Under the Mac OS, the Commander HD will appear on the “Desktop.”
7. At this time it is recommended to remove the digital key-token and keep it in a safe place.
8. Click (double click) on the Rocstor HD icon to access the drive.

NOTE: as long as the drive is ON it performs as any standard external drive; therefore all the data which is being read (decrypted) is open to be accessed at all time while the drive is in the ON position. Once the drive is tuned OFF the digital key must be inserted back in for authentication. (However, it encrypts and decrypted all the date that is being read and written to the drive at all time).

Cable Types

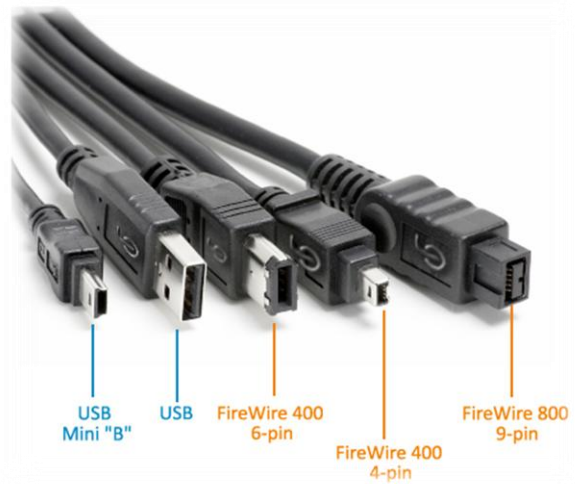

FireWire 400 (IEEE 1394a) 6-Pin FireWire 400 connector

- FireWire 400 can transfer data between devices at 400 Mbits/sec

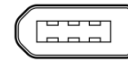

FireWire 800 (IEEE 1394b) 9-Pin FireWire 800 connector

- FireWire 800 can transfer data between devices at 800 Mbits/sec

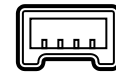

USB supports three data transfer rates:

- USB 3.0: A Super-Speed (USB 3.0) rate of up to 5,000 Mbits/s (1GB/3.3sec)
- USB 2.0: A Hi-Speed (USB 2.0) rate of 480 Mbits/s (60 MB/sec)
- USB 1.1: A **Full Speed** rate of 12 Mbits/s (1.5 MB/sec)
- USB 1.0: A **Low Speed** rate of 1.5 Mbits/s (187 KB/sec)

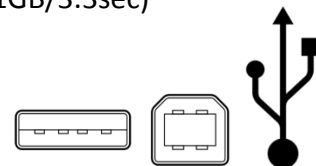

INSTALLING YOUR DRIVE

All Rocstor hard drives are formatted as blank FAT32 (32-bit file allocation table) volumes {unless otherwise stated on the box} that are compatible with most modern Windows and Macintosh operating systems. To begin using your Rocstor drive, simply connect a data cable and power cord. There's no need to shut down your computer because your Rocstor drive is hot-pluggable. Just plug it in and it's ready to use.

The first choice you have to make is which of the provided data cables to use. The drive can connect directly to any available FireWire or USB port on your computer, or it can be Daisy-Chained to your computer through another compatible device with an available FireWire port. The ability to Daisy-Chain allows you to have multiple drives connected simultaneously, greatly increasing your available storage capacity. Daisy-Chain is only available through FireWire ports.

If you intend to use the drive for additional storage only—not as a startup device (bootable) use the cable that provides the maximum throughput rate for the buses available on your computer: Up to 800 Mbits/sec via FireWire 800, Up to 480 Mbits/sec via USB 2.0, Up to 5,000 Mbits/sec via USB 3.0, Up to 400 Mbits/sec via FireWire 400, 12 Mbits/sec via USB 1.1 or Up to Up to 3,000 Mbits/sec via eSATA. To avoid damaging your hardware and losing data, never simultaneously connect the drive to the computer using more than one data cable.

Commander as a bootable device

If you intend to use the drive as a startup device, check the documentation that came with your computer to confirm compatibility with the various interfaces. PowerPC-based Macs require FireWire connections for startup disks, whereas Intel-based Macs can use either FireWire or USB connections.

Furthermore, using the drive as a startup device requires installing an authorized copy of the Windows or Mac operating system (available separately from Microsoft and Apple, respectively). To install the Mac OS 9 or OS X, you must reformat the drive as a Mac OS Extended volume with Disk Utility. An Intel-based Mac cannot start from a device formatted on a PowerPC-based Mac or vice versa.

Disconnecting Your Drive

Never disconnect or turn off an external drive when its activity light is ON. External drives must be properly unmounted (or disconnected) to avoid data loss and possible damage to the hard disk drive or computer.

PC

The easiest ways to safely unmount an external hard drive on your PC is to right-click the device removal icon next to the clock in the system tray. Then choose Safely Remove Hardware. Choose the external device you want to remove, and then click Stop. An alert will notify you if the drive is in use by an application. If in use close any open documents or applications on the

drive and try again. Windows will display an alert when you can safely disconnect or turn off the drive.

Mac

The easiest way to safely unmount an external hard drive is to drag its Finder icon to the Trash. An alert will notify you if the drive is in use by an application. Close any open documents or applications on the drive and try again. When the drive's icon no longer appears on the Finder's Desktop and the drive's activity light is green, you can safely disconnect or turn off the drive.

Reformatting Your Drive

As mentioned previously, all Rocstor hard drives are formatted as blank FAT32 volumes (otherwise noted on the retail packaging) that are compatible with most modern Windows and Macintosh operating systems. However, you can use your normal disk management tools to erase or reformat the drive if needed. For example, Windows users may want to reformat the drive as an NTFS (new technology file system) volume, or Mac OS X users may wish to reformat the drive as a Mac OS Extended (Journal) or UFS (Unix file system) volume.

Please note that all of your data will be lost if the volume (Hard Drive) is formatted or reformatted.

Reformatting via PC (Window based computers)

Right-click the Commander drive in the "My Computer" folder, then choose Format. In the dialog window that appears, choose the desired capacity, file system and allocation unit size and then click Start.

Reformatting via Mac

Open Disk Utility (/Applications/Utilities). Select the drive in the list at the left, and then click the Erase tab. Choose the desired volume format, specify a name, and then click Erase.

Important Note

Any cable (FireWire or USB) inserted before the drive is powered on has priority over the other cables and will be the primary connection method, e.g. if the drive is connected via FireWire 800 before powering on the drive, data will be transferred via FireWire 800.

The drive should only be connected to a computer via **one** interface at a time. Connection of the drive to a computer via two or more interfaces is not recommended and may potentially damage your Commander drive and data.

PARTITIONING AND FORMATTING THE COMMANDER DRIVE ON A MAC OS

All Rocstor drives are factory formatted with FAT32, unless otherwise stated on the retail box.

WARNING: Formatting and Partitioning the Commander Drive will destroy all of its data. To protect your data, back it up before formatting or partitioning this device.

IMPORTANT NOTES:

1. All programs should be closed before beginning.
2. Connect the Rocstor hard disk drive to your computer using the appropriate cables.
3. Turn ON the Rocstor hard disk drive. Some Rocstor HDs are bus-powered and turn ON automatically. Look for a Blue or Green light.
4. "Click" means left click. "Right Click" will be so labeled.
5. Some computers are set so a single "click" will perform the task, such as opening a window. Depending on your mouse setting, you may have to double click to get to the next window. If a single click does not open the next window, please double click.

INSTRUCTIONS FOR PARTITIONING AND FORMATTING FROM FAT32 to HFS+:

1. Connect the Rocstor drive to the computer via a port.
2. The drive will appear as an icon on the Desktop on the middle right side (figure 1.0 below) the icon will represent the method of connection (USB or FireWire).



Figure 1.0





USB Connection

Figure 1.1



FireWire Connection

Figure 1.2

Note: If the Hard Drive is connected via USB port, the desktop would indicate the **USB**  (figure 1.1) if it is connected via **FireWire**  port, it would then indicate **FireWire** as (figure 1.2) on the **“Macintosh HD”** icon. The same procedures would also apply to the following steps.

3. Once the icon appears on the **“Desktop”** click on the **“Macintosh HD”** icon (figure 2.0)

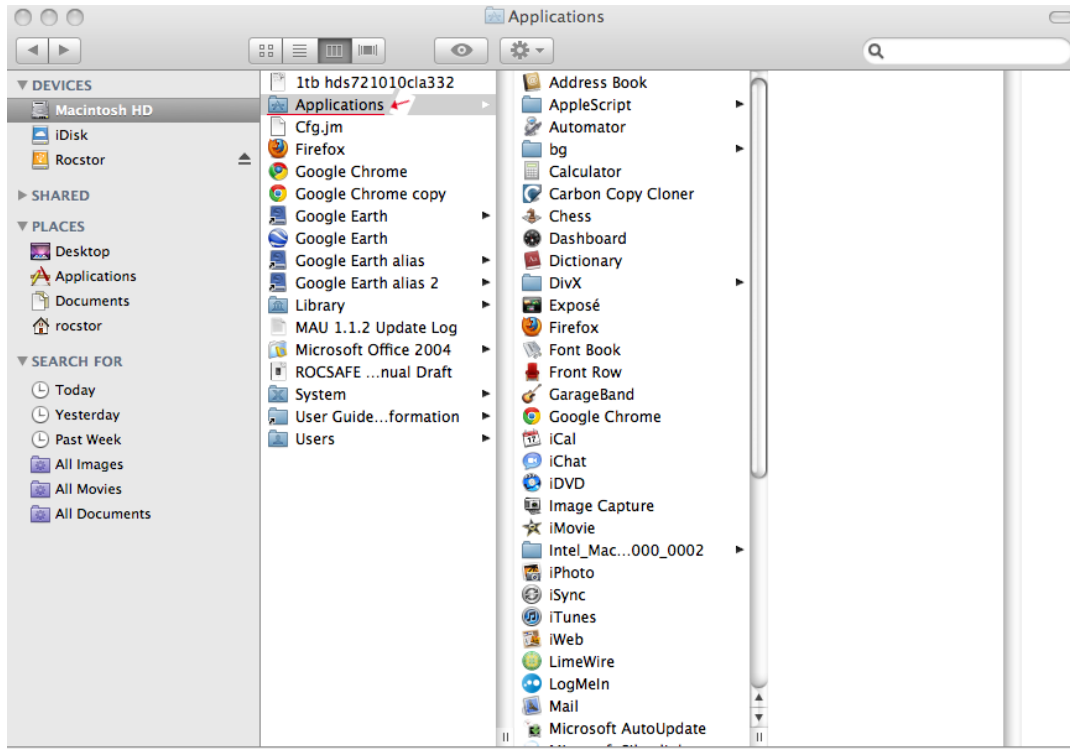

Figure 2.0

4. In the “Macintosh HD” menu, click on the “Applications” icon.
5. In the “Applications” menu, click on the “Utilities” icon (figure 3.0.)

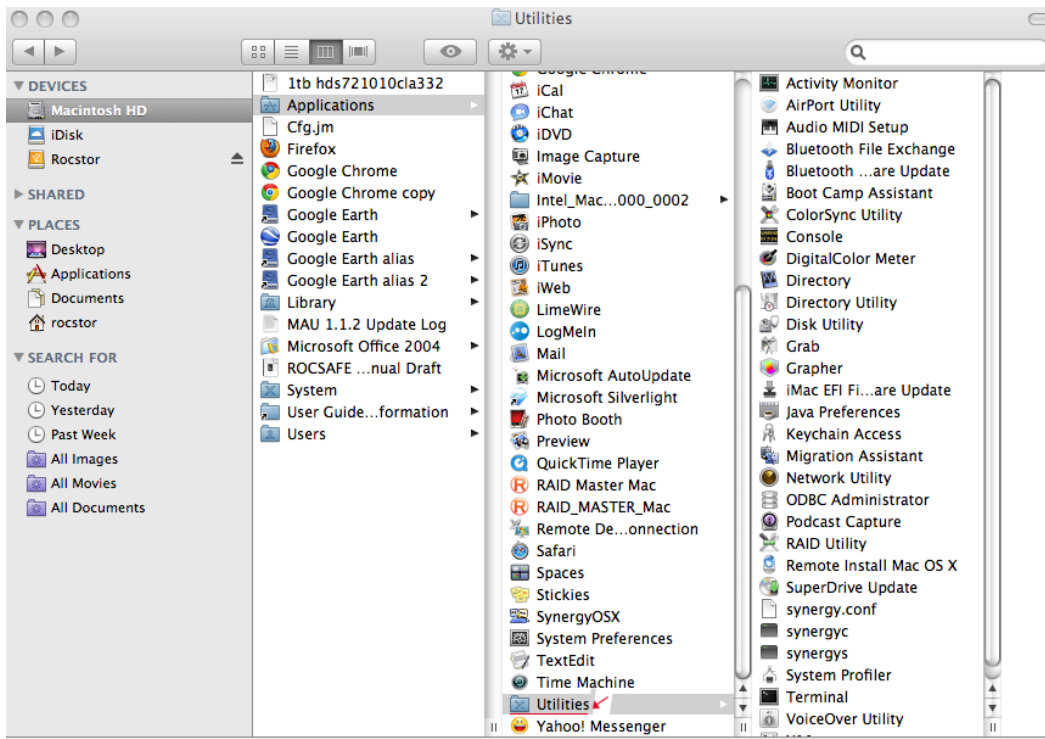

Figure 3.0

6. In the “Utilities” menu, click on the “Disk Utility” icon (figure 4.0.)

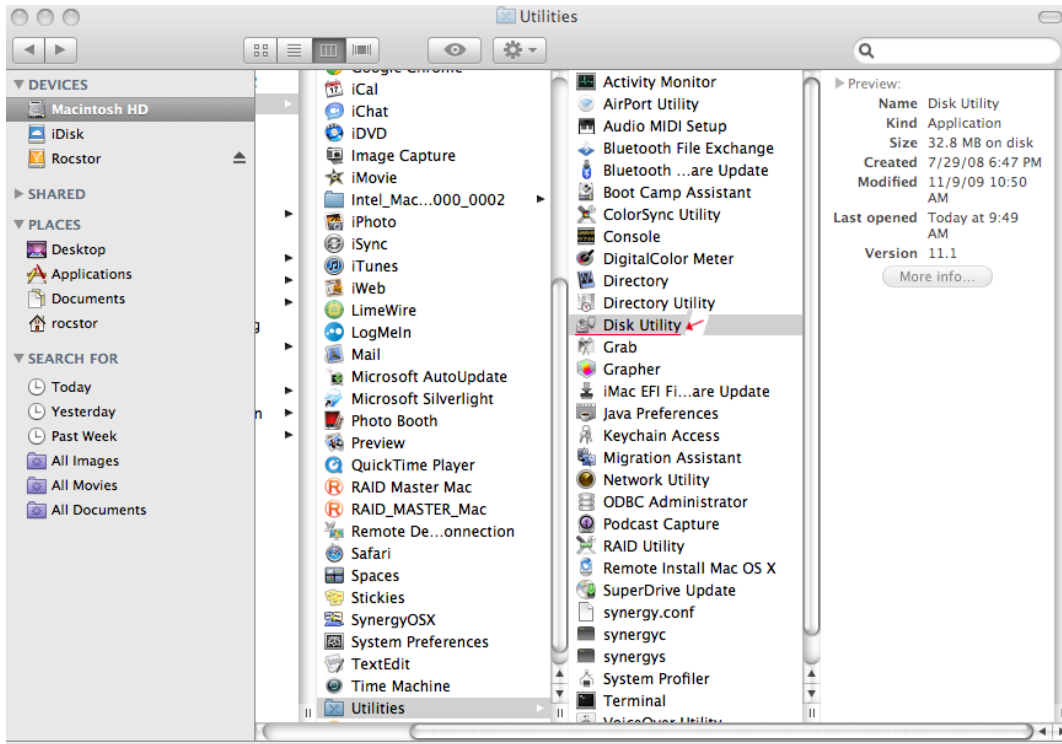

Figure 4.0

7. On the left side of the “**Disk Utility**” menu is a list of available drives (figure 5.0.) One will show as Rocstor drive. Click on the icon showing the disk capacity (figure 5.1.)

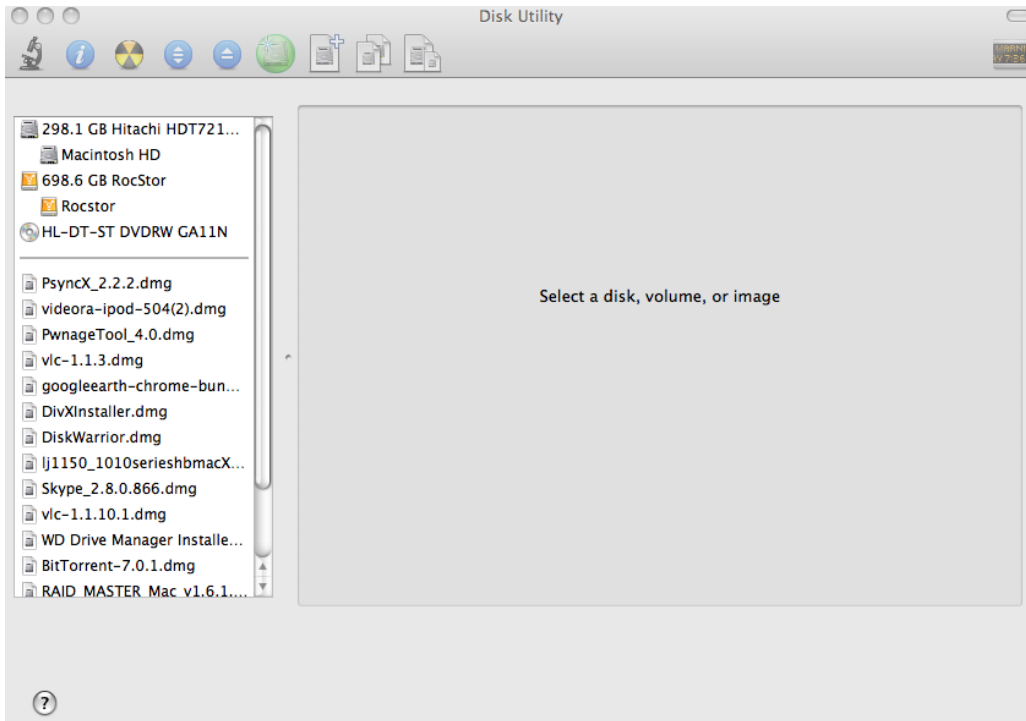

Figure 5.0

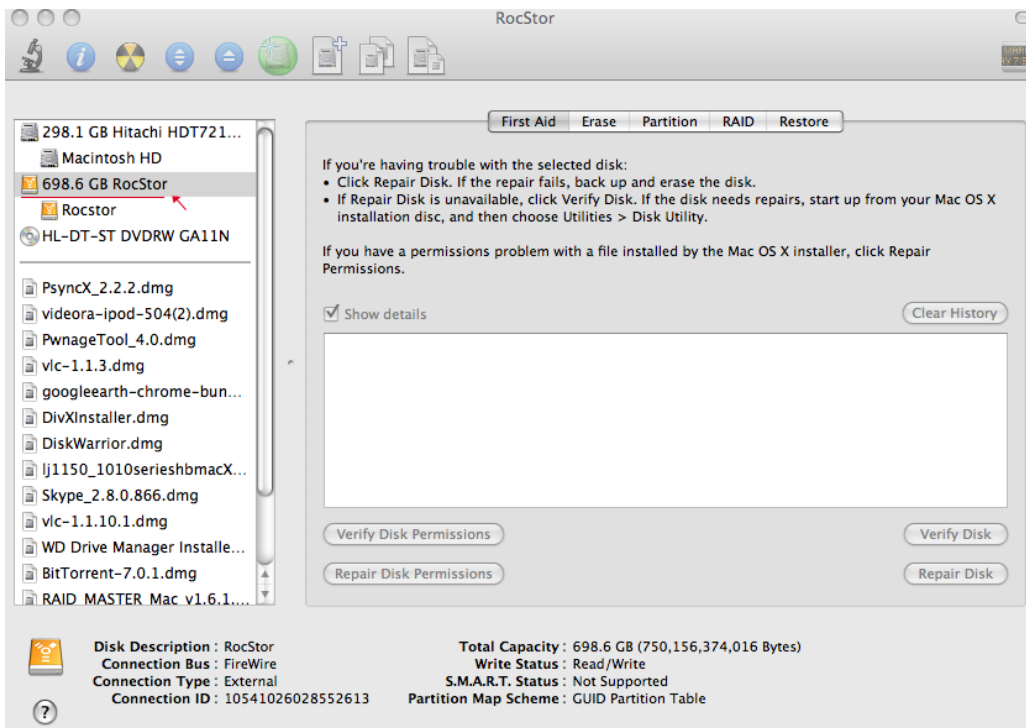

Figure 5.1

8. You are now in the Rocstor menu. Click on the **“Partition”** tab and then click the **“Current”** tab under **“Volume Scheme.”** A drop down **“Partition”** menu will appear.
9. In the **“Partition”** menu, you may select any number of partitions available under **“Volume Scheme.”**
10. If you are using Panther proceed to #13 below.
11. If you are using Tiger, Leopard, Snow Leopard or Lion click on Options on the lower center of the window. Select the Partition Scheme for your Rocstor drive. Suggest you select **“Apple Partition Map”** for Tiger, Leopard, Snow Leopard and GUID partition table for Lion, (figure 6.0) and then click OK.

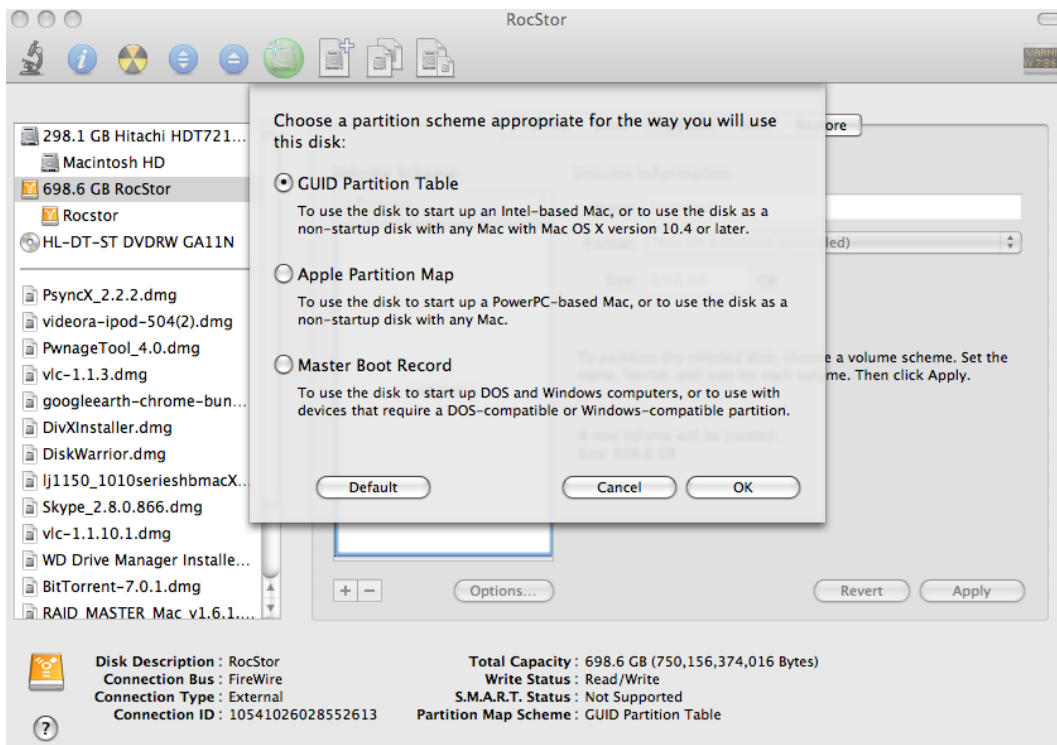

Figure 6.0

12. Volume Information: select a name for your drive (figure 7.0)

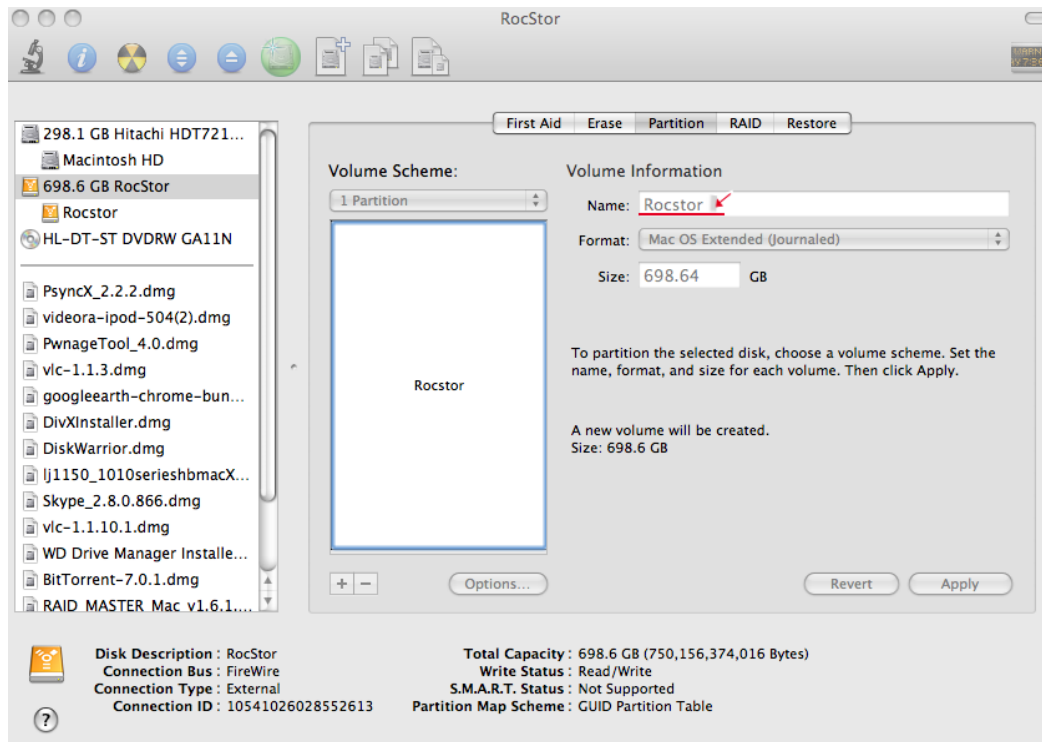

Figure 7.0

13. Format: Click on either the “**Format**” area or the Blue up/down arrows. Select **Mac OS extended (journal)**.

14. After selecting the type of format, click the **“Apply”** tab in the lower right of the screen, (figure 7.1.) On the next screen, Partition Disk, click **“Partition”** (figure 8.0)

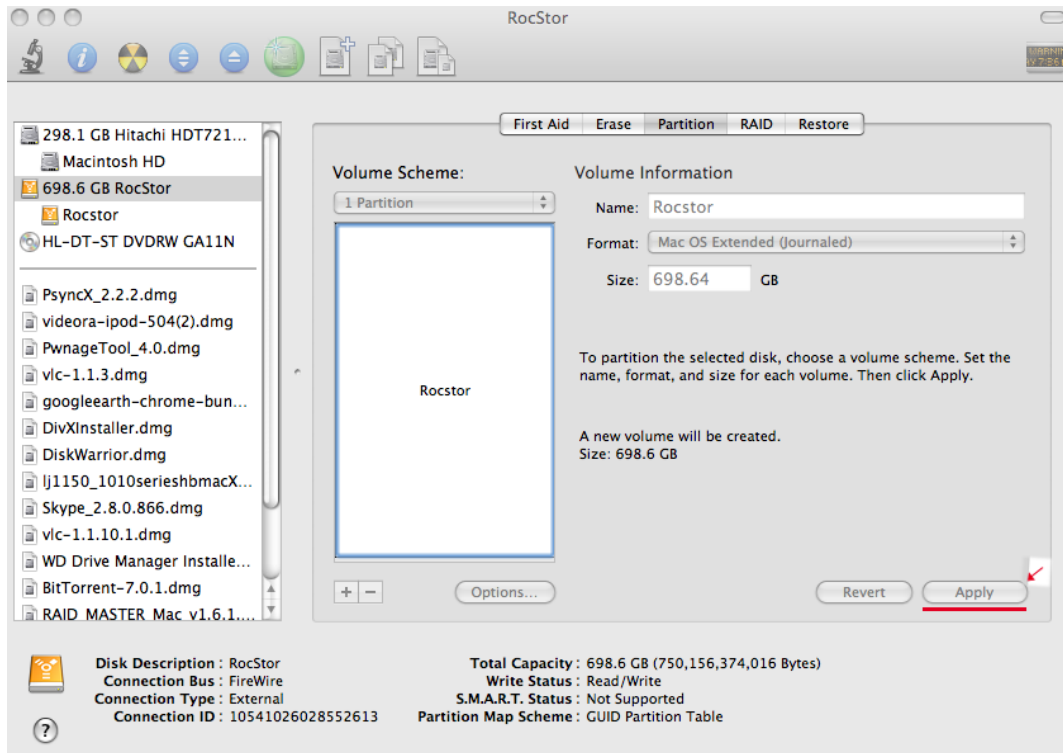

Figure 7.1

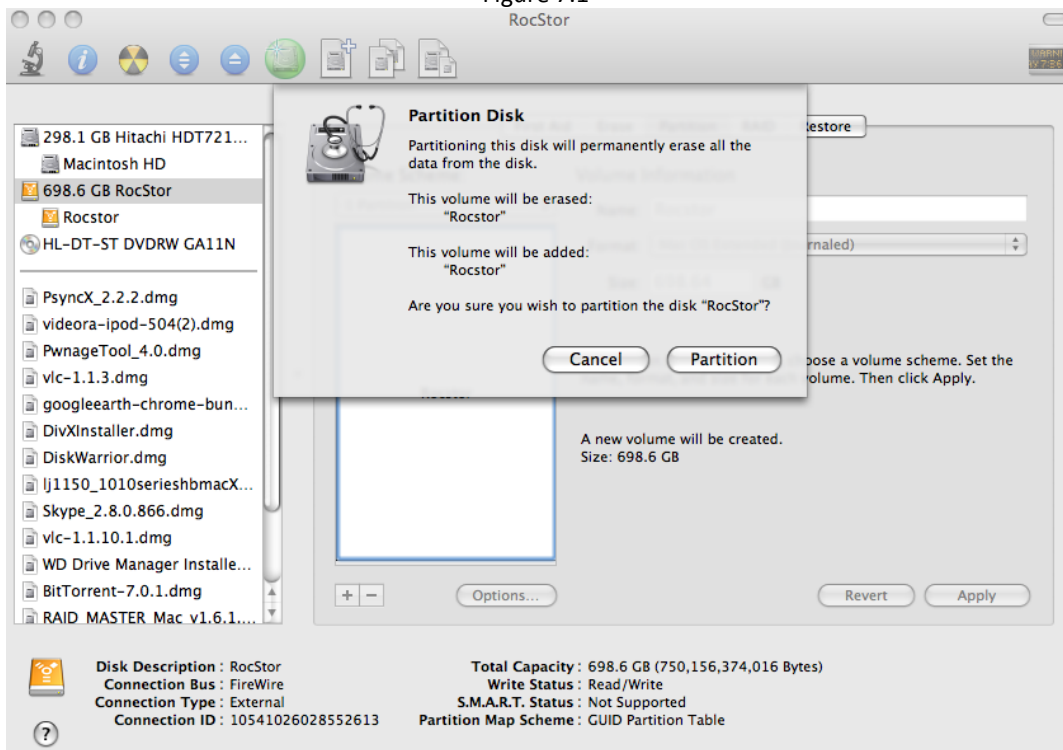

Figure 8.0

15. The drive will begin to format (figure 8.1) and upon completion; the same icon that first appeared on the Desktop will reappear with your designed name on the Desktop (figure 9.0)

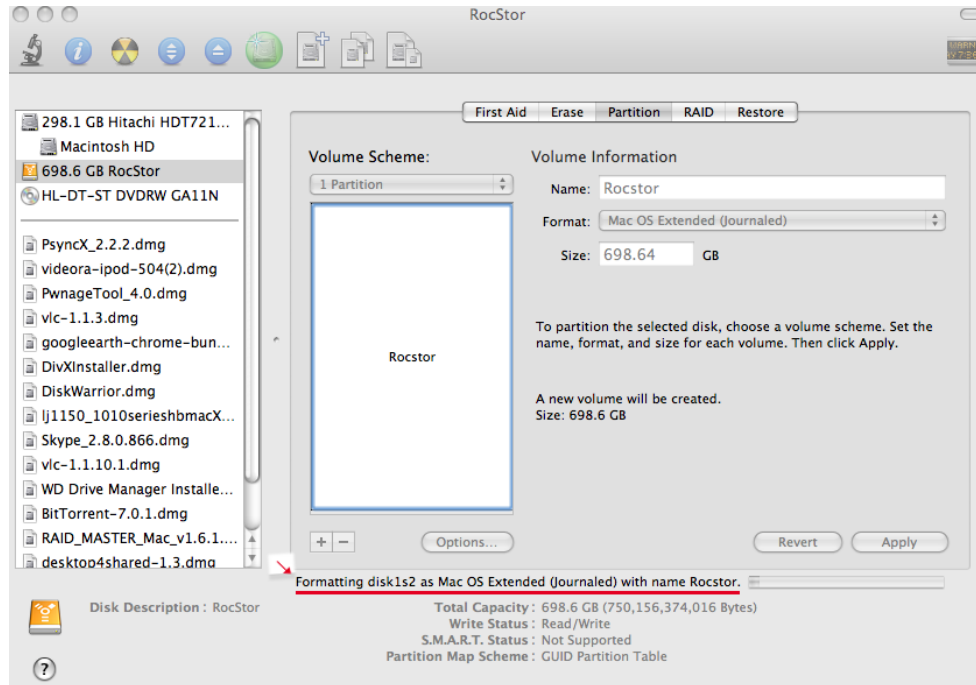

Figure 8.1

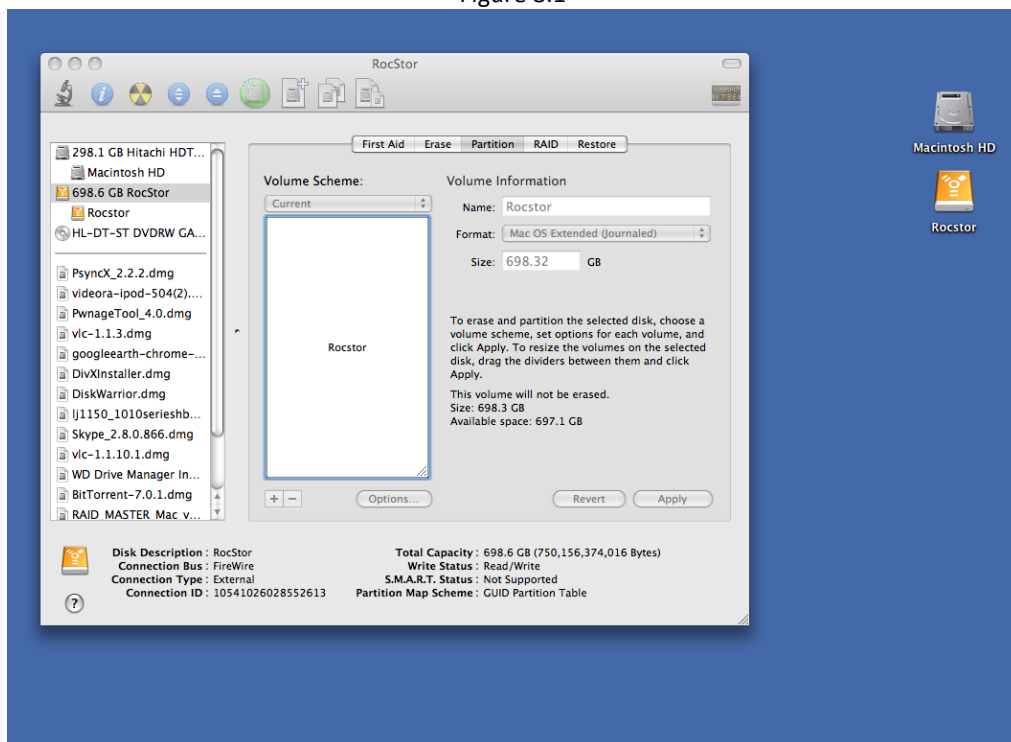

Figure 9.0

16. You can now Exit or close to return to the desktop.

PARTITIONING AND FORMATTING THE COMMANDER DRIVE ON WINDOWS 2000, XP AND VISTA and Windows 7

All Rocstor drives are factory formatted with FAT32, unless otherwise stated on the retail box.

WARNING: Formatting and Partitioning the Commander Drive will destroy all of its data. To protect your data, back it up before formatting or partitioning this device.

IMPORTANT NOTES:

1. All programs should be closed before beginning.
2. Connect the Rocstor hard disk drive to your computer using the appropriate cables.
3. Turn ON the Rocstor hard disk drive.
4. The initial goal is to reach the Control Panel. If you know how to get there, skip this section and go directly to Instruction 1 (Instructions for Partitioning and Formatting from FAT 32 to NTFS.) A fast way of reaching "Disk Management" is to right click "My Computer" icon and left click on "Manage" in the drop down menu. The next window is "Computer Management."
In the left menu, click "Disk Management."
5. The ultimate goal is to reach Disk Management. If you know how to get there, skip this section and go directly to Instruction 4 (Instructions for Partitioning and Formatting from FAT 32 to NTFS).
6. Due to different views that are possible on Windows operating systems (2000, XP, Vista, Windows 7), we will provide various ways of reaching the Control Panel.
7. "Click" means left click. "Right Click" will be so labeled.
8. Some computers are set so a single "click" will perform the task, such as opening a window. Depending on your mouse setting, you may have to double click to get to the next window. If a single click does not open the next window, please double click.

DIFFERENT WAYS TO GET TO THE CONTROL PANEL:

(You may use any one of the following methods)

1. If the icon “My Computer” shows on your desktop, click or double click on the icon. Under “Other Places” click on “Control Panel.”

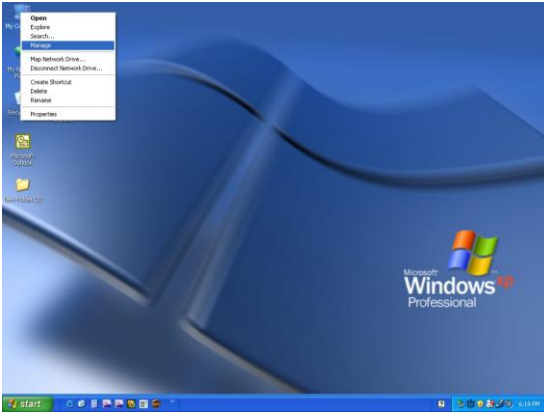

Under Windows XP

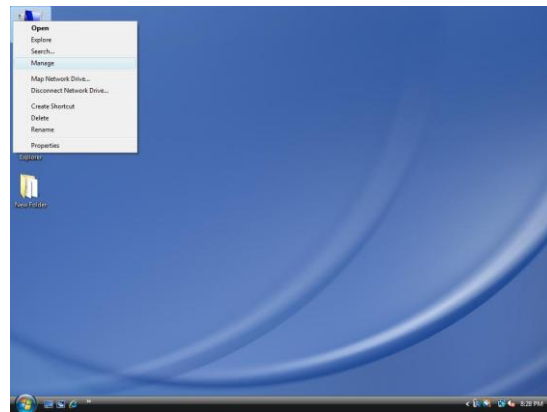

under Vista/Windows 7 OS

2. If the icon “My Computer” does not show on your desktop, click on the Start icon on the lower left of your screen. If the Control Panel link is displayed, click on the Control Panel link.

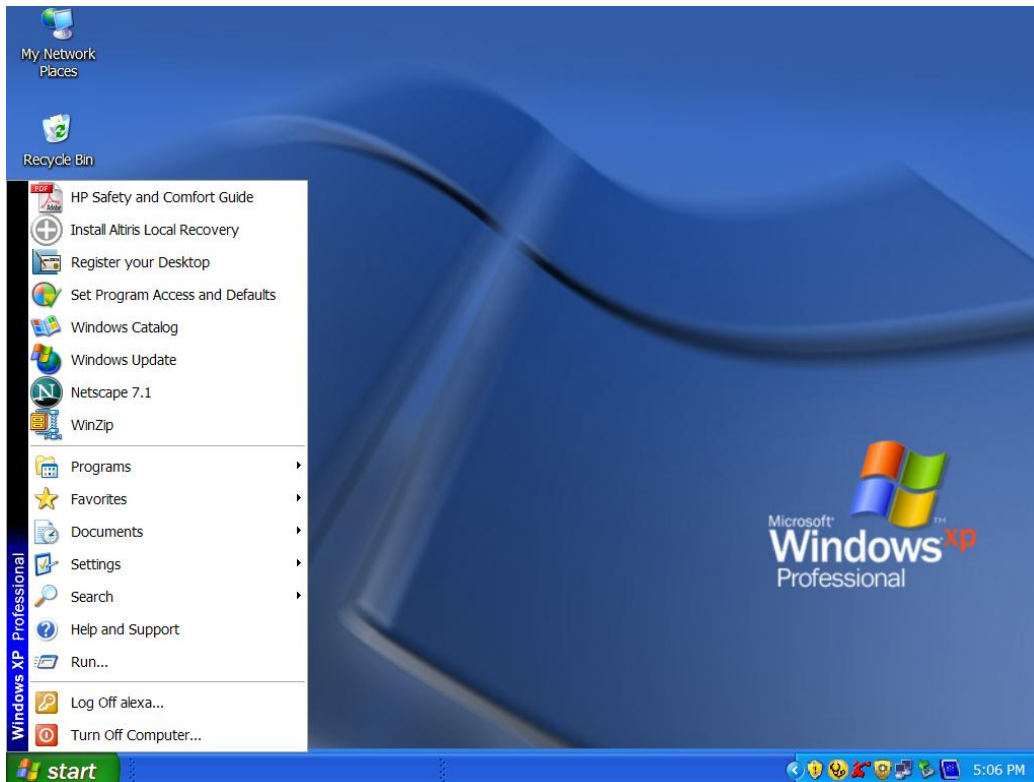

3. If the icon “My Computer” does not show on your desktop, click on the Start icon on the lower left of your screen. If the Control Panel link **is not** displayed, click on the Settings link and then click on the Control Panel link.
4. Click on the Start icon on the lower left of your screen. Click on Run. Delete anything listed in the Open window. Type the following: compmgmt.msc and then click OK. Skip to INSTRUCTION # 4 (Instructions for Partitioning and Formatting from FAT 32 to NTFS {page 24}).

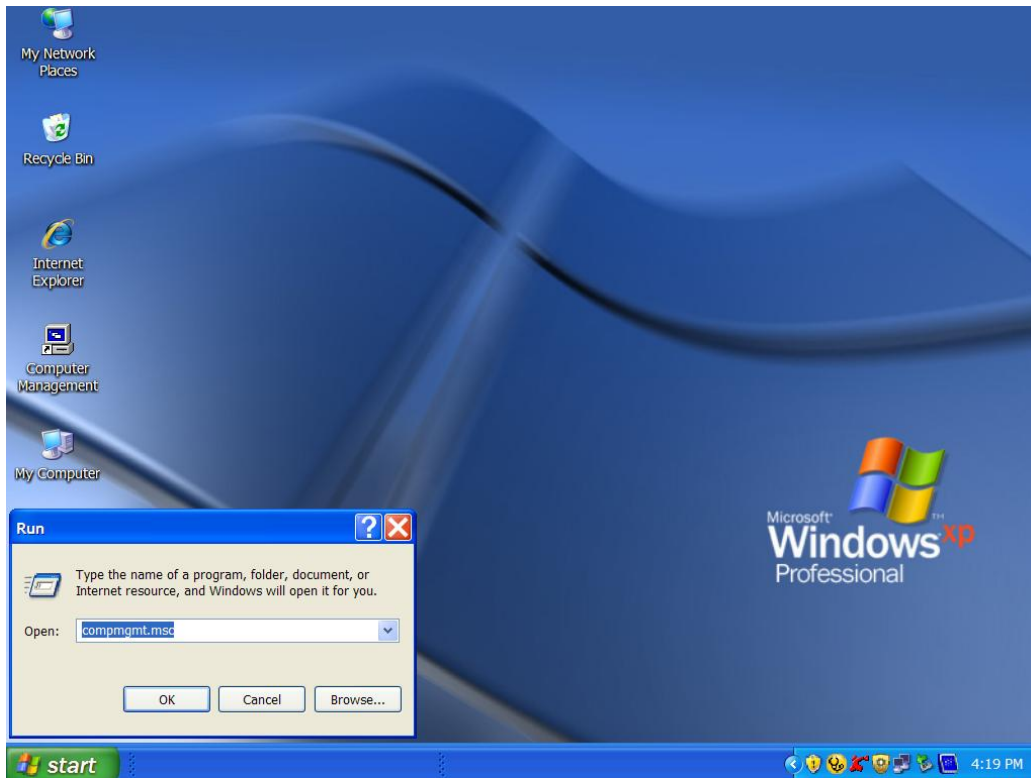

INSTRUCTIONS UPON REACHING CONTROL PANEL

- a. After reaching the Control Panel, click on Administrative Tools.

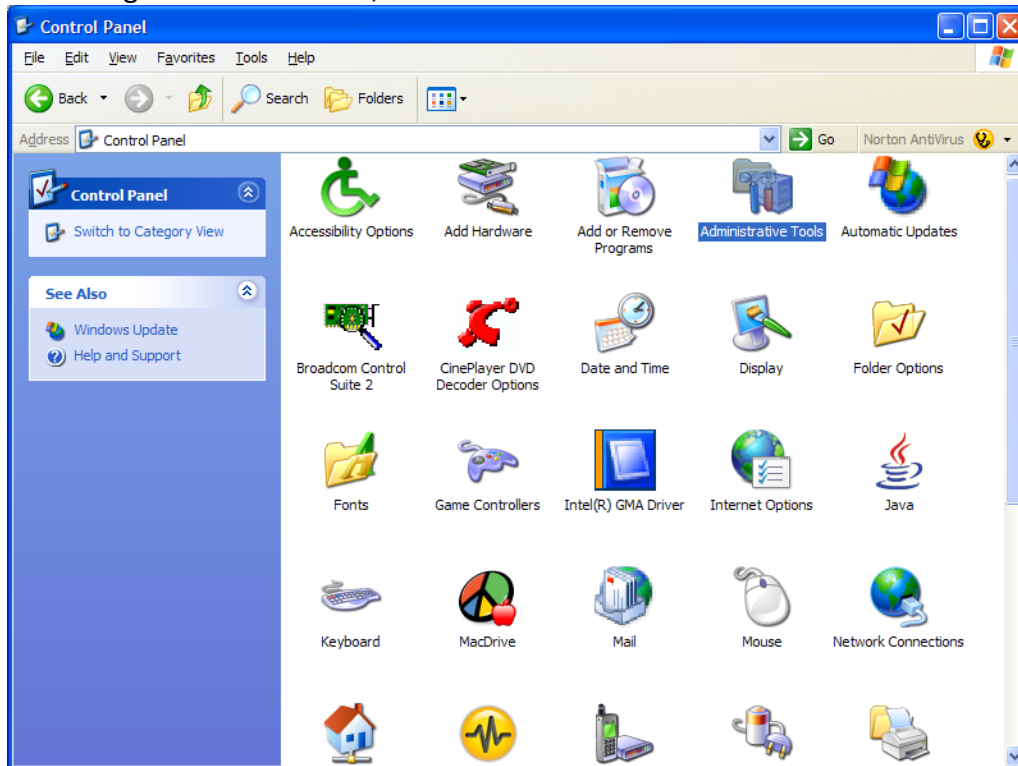

- b. After reaching Administrative Tools, click on Computer Management.
c. After reaching Computer Management, click on Disk Management.

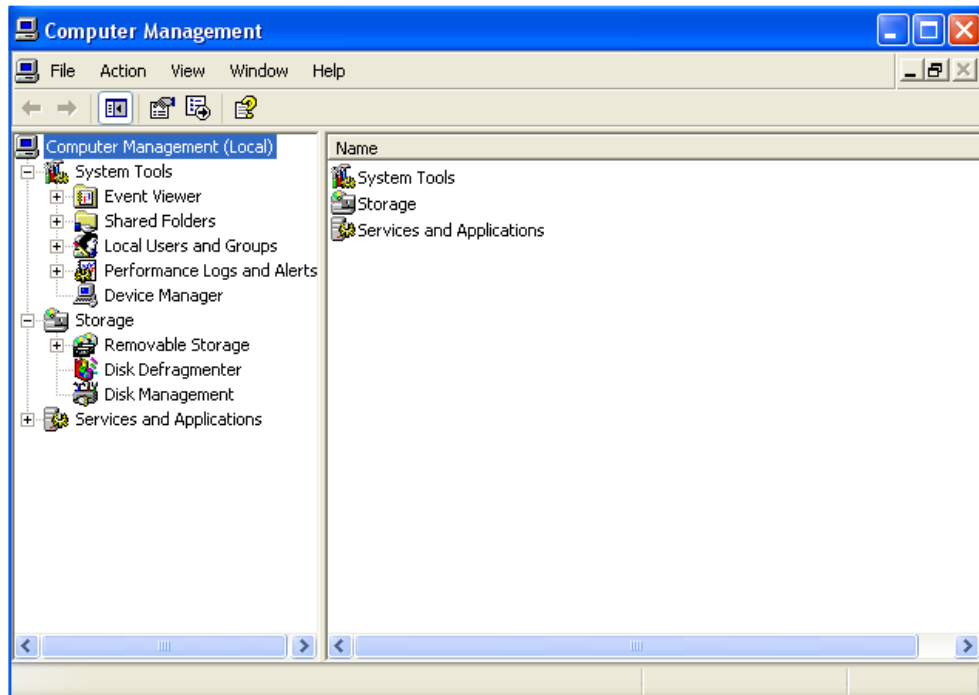

INSTRUCTIONS FOR PARTITIONING AND FORMATTING FROM FAT32 to NTFS

1. In the “Disk Management” window, right click the Rocstor drive in the upper portion of the menu to highlight it. In the drop down menu, select “Delete Partition.”

WARNING: Formatting and Partitioning the Commander Drive will destroy all of its data. To protect your data, back it up before formatting or partitioning this device.

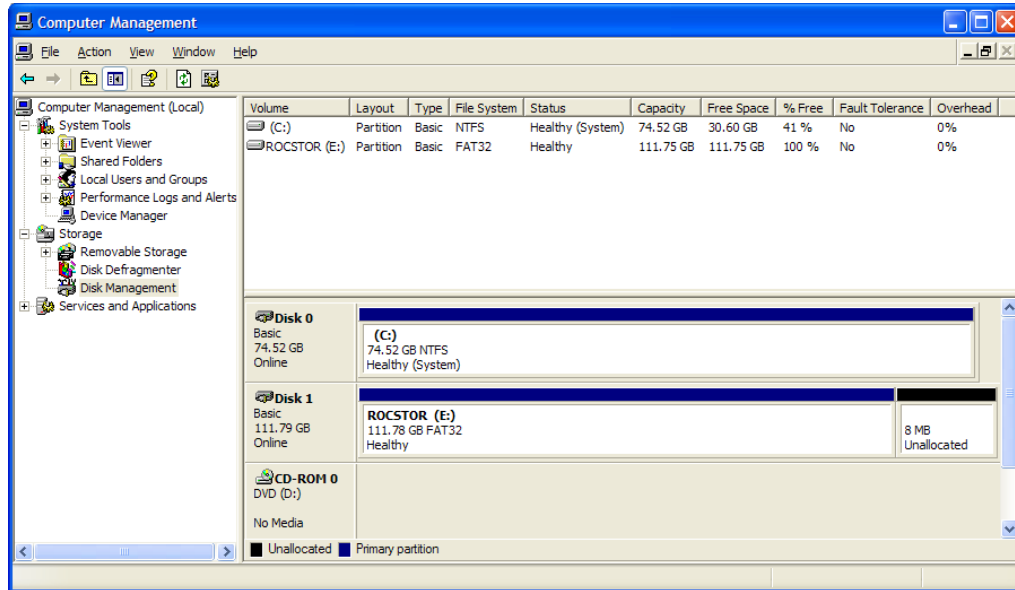

2. The next window is “Delete primary partition.” Click on Yes.

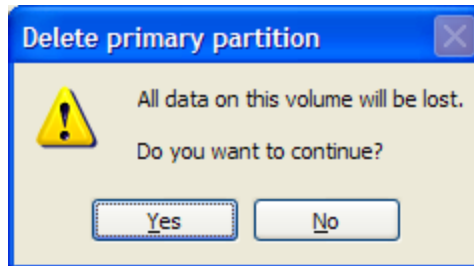

3. At this point the Rocstor drive will not show up on the “Disk Management Volume” window in the upper menu.

4. The Rocstor drive will show up in the lower menu as an “Unallocated” disk.

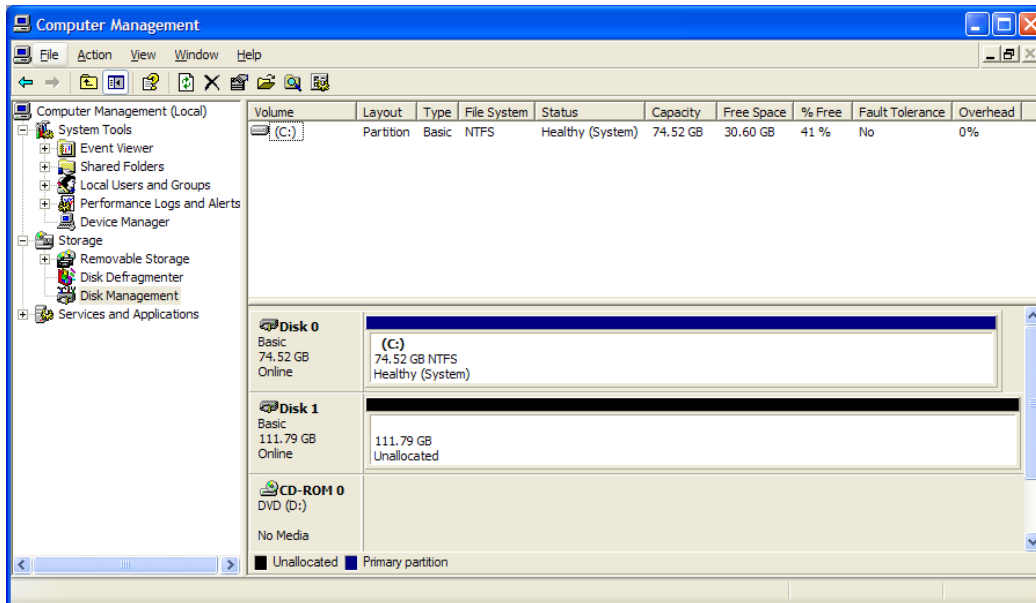

5. Right click anywhere in the “Unallocated” disk area in the lower menu.
6. Click on “New Partition.”
7. You are taken to “Welcome to the New Partition Wizard.” Click “Next”.

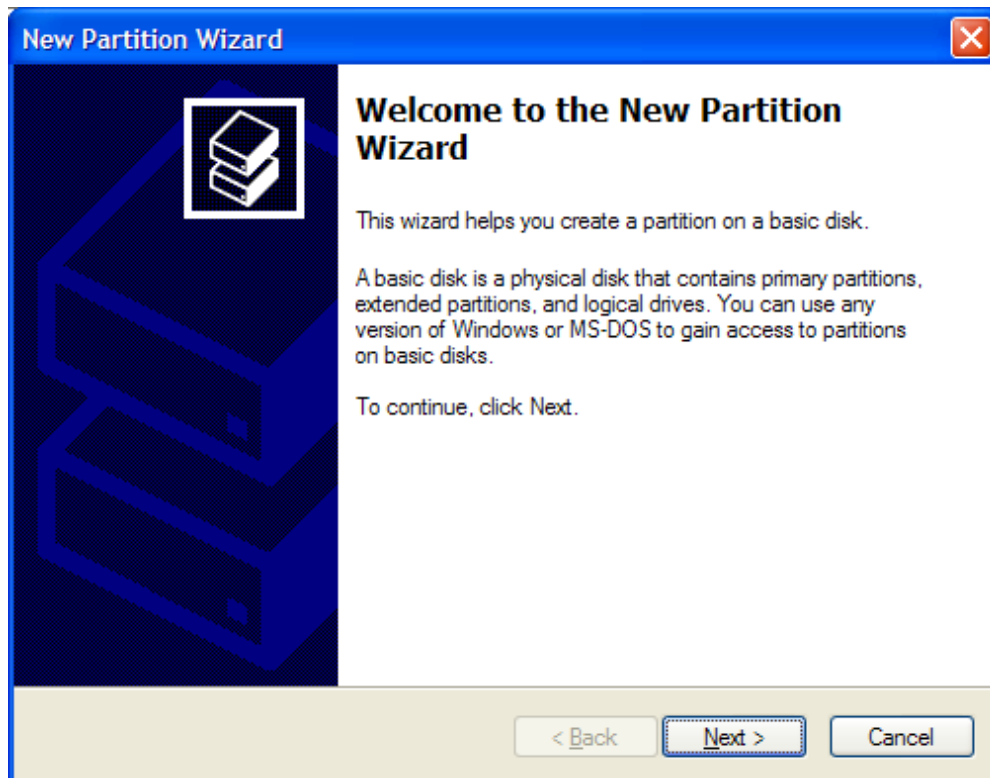

8. Click on “Primary partition” (it should be selected as the default partition). Click “Next”.

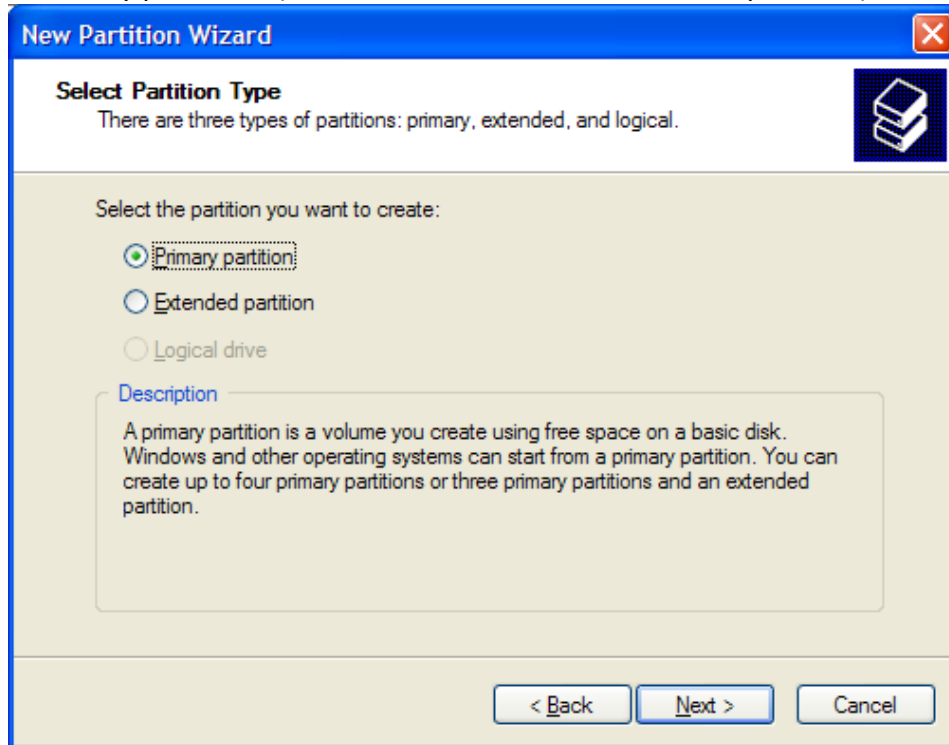

9. Under “Specific Partition Size,” click Next to accept the default setting, which is the maximum size allowed.

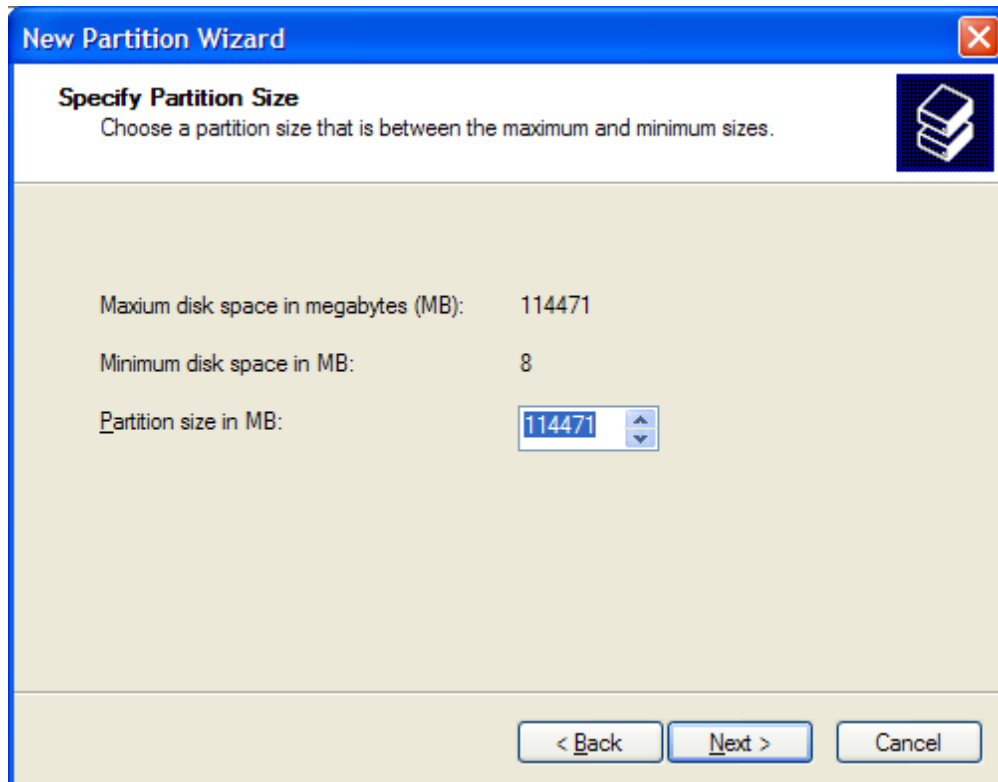

10. Under “Assign Drive Letter or Path,” accept the default letter and click “Next”.

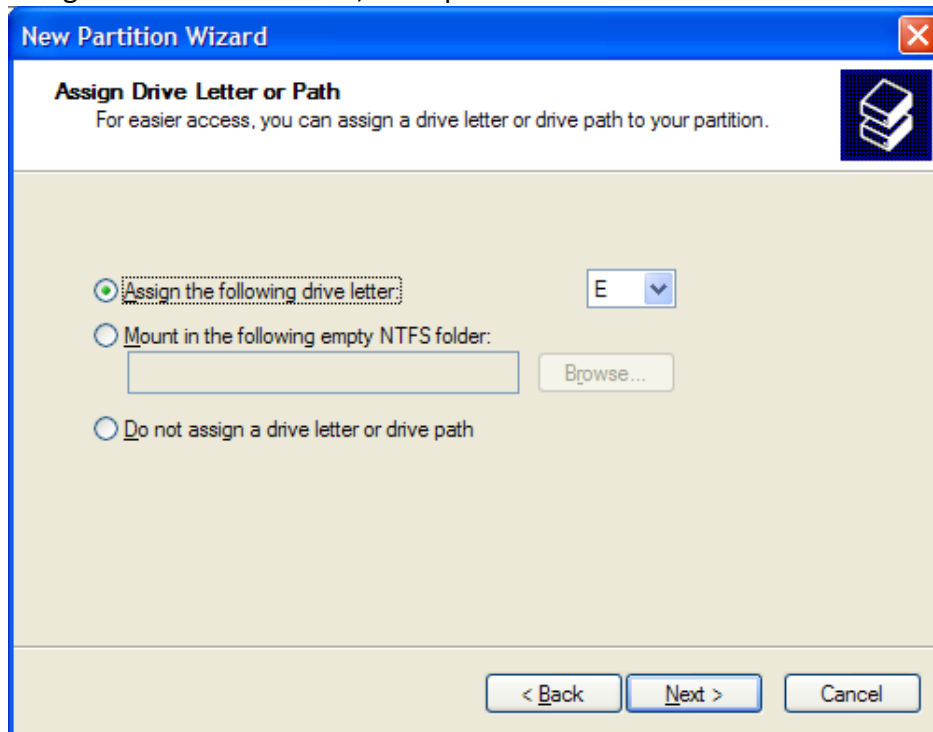

11. In the “Format Partition,” accept the default setting.

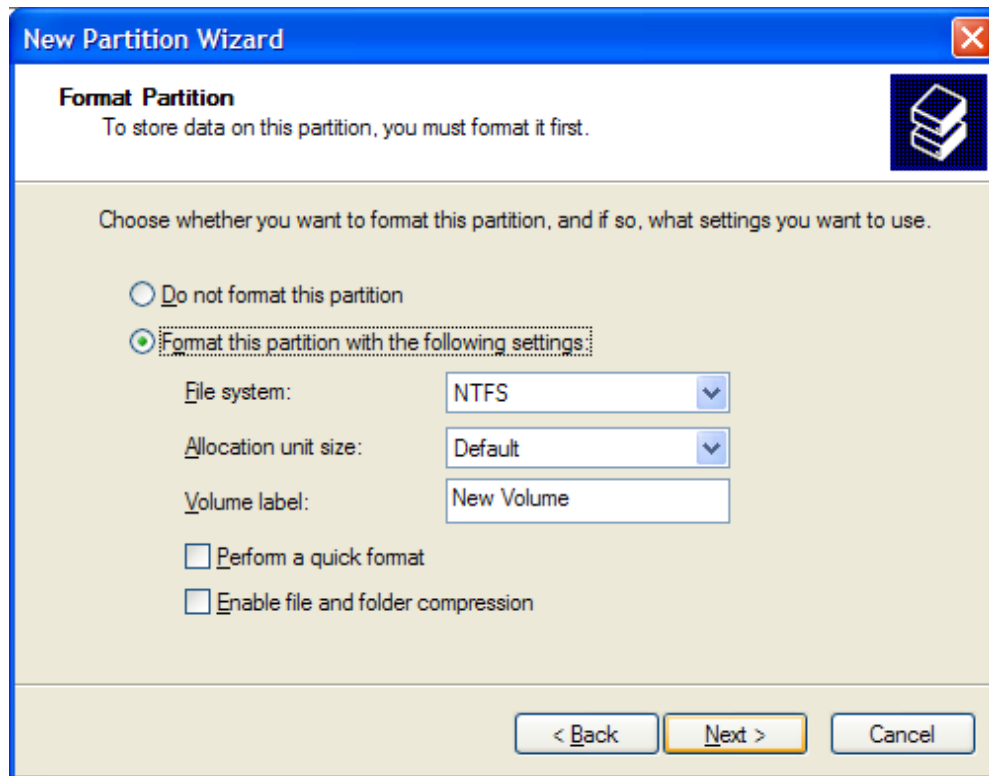

12. The “Volume label” can be changed to any name up to 11 characters.
13. Suggest that “Quick Format” be selected and then click “Next”.
14. You now reached the “Completing the New Partition Wizard” screen. It displays the various settings you previously selected. If you are satisfied with your selections, click “Finish” to complete the new formatting. At this time the Rocstor disk drive is being formatted, which may take a few minutes.

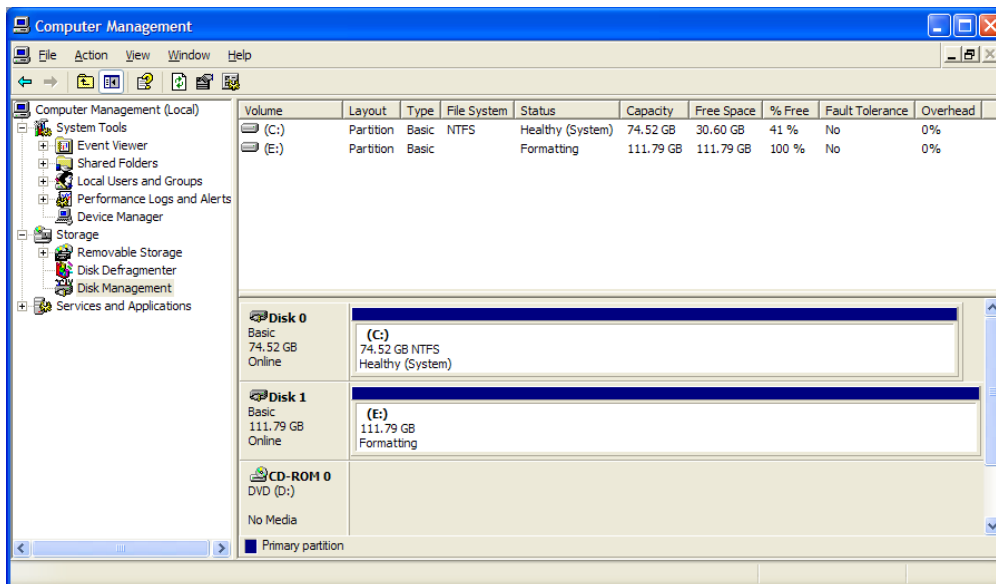
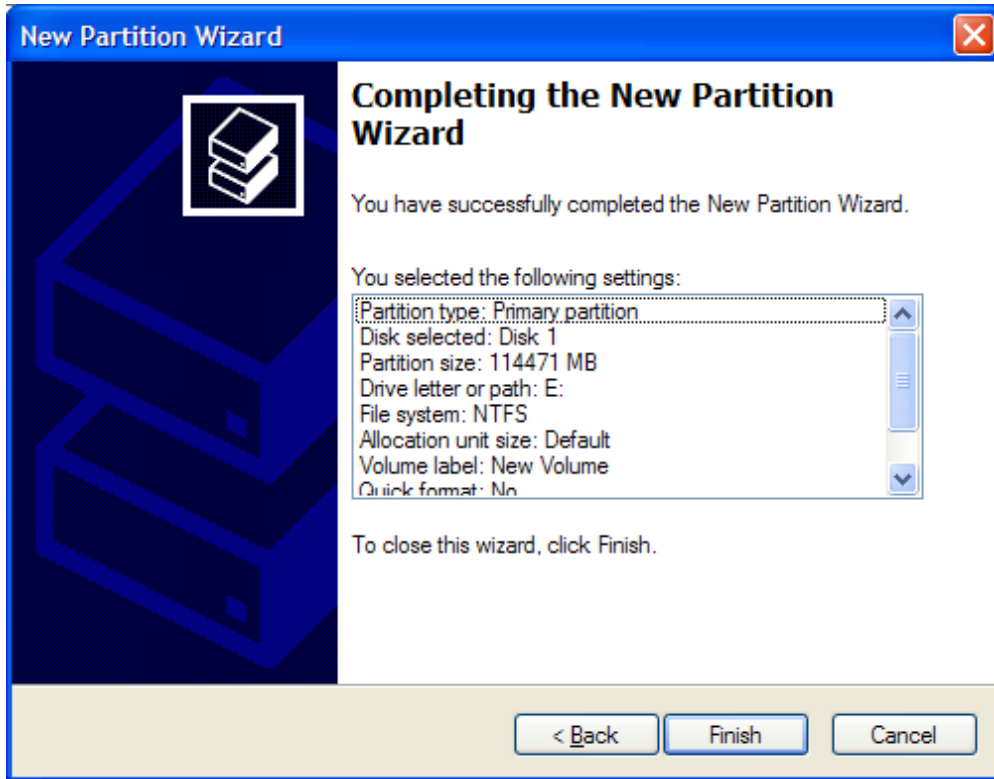

15. You will return automatically to the “Disk Management” window and will see the newly formatted Rocstor disk on the screen with the name you selected. If no new name was entered in the “Volume label,” the Rocstor drive will show up as “New Volume.” To rename the volume at this time, right click “New Volume” and click “Properties.” You can now change the volume name up to 11 characters. Click OK.

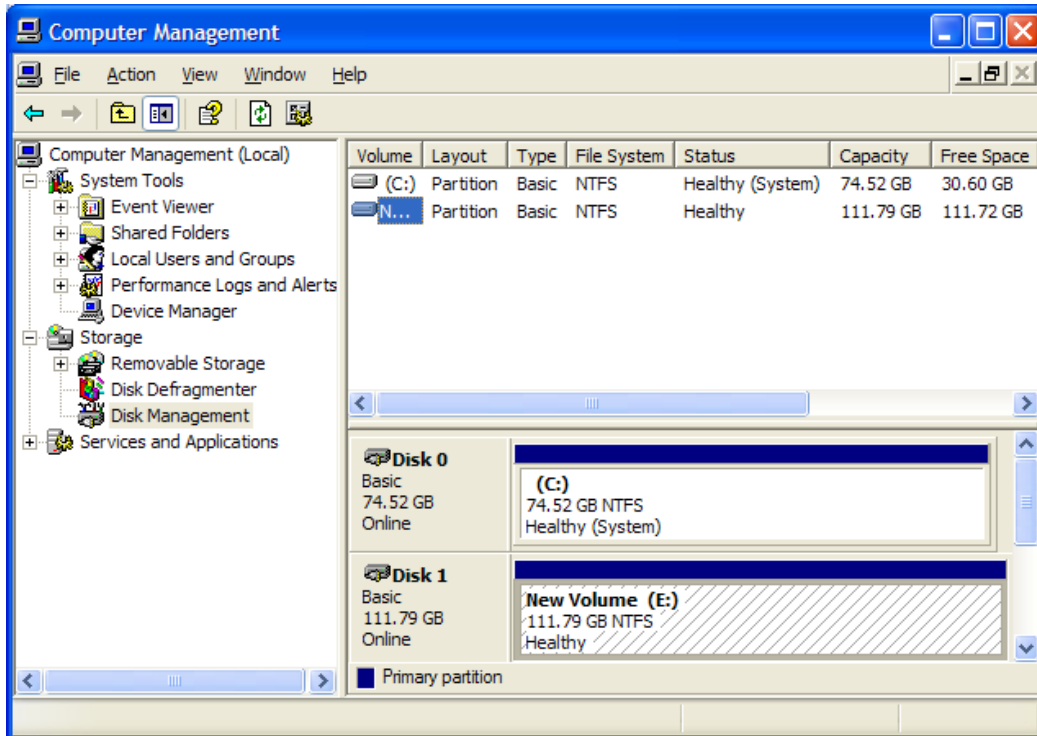

16. You can also change the name at any time in the future by reaching the “Properties” menu of the Rocstor drive.

17. You can now Exit or close to return to the desktop.

Troubleshooting

Rocstor data storage products are subjected to several quality control tests before leaving our factory. However, from time to time, the product may not work after shipment or would experience intermittent problems under certain criteria and/or situations. Should you experience a problem with your Commander HD, please review the Manual and read the possible solutions that fit your problem. (The User Manual is updated regularly so check the Rocstor website for an updated Manual). Please contact Rocstor technical support listed under contact information at the end of this Manual.

Troubleshooting for MACINTOSH computers

Problem: The computer does not recognize the drive

Solutions:

- Is the Commander Green light ON and is the cable connected from the HD device to the computer. Commander HD icon should appear on the desktop. Continue to review this guide to find the solution.
- Your computer's Minimum requirements may not meet the minimum system requirements as indicated in this Manual. Page 8
- Confirm that the outlet is providing the correct voltage and the electrical power cord is securely attached to both the outlet and the Commander drive. Poor or loose connections can result in loss of power and possible damage to the drive. Ensure that the ON/OFF switch is turned to the ON position.
- If the Commander drive is connected to an outlet via an Uninterrupted Power Supply (battery Backup) or a surge protector, be sure that they provide the correct voltage and they are all switched "ON" and receiving electricity.
- Please review this Manual's installation procedure for the operating system and interface you are using.
- Read the Manual's installation procedure to ensure it was properly followed.
- Please check the cable connections as the cables must be properly and securely attached to the computer and hard drive. Ensure that there is a firm connection. It is suggested that the cables be detached and reattached, and that the computer be shut off for 20 seconds and then restarted.
- Ensure that the Commander drive has been properly reformatted by reviewing the User Manual.

- Have you checked to confirm that the computer's operating system works with the file system?
- Review the manual that came with your computer to ensure that the file system is compatible with the operating system.

Problem: The Commander drive is not working fast enough.

Solution:

- You may have too many devices connected to your computer (such as Laptop computers.) Disconnect some devices and observe if there is an improvement in performance.

Problem: There is a decrease in performance when the Commander drive is connected via the USB cable to a USB 3.0 port.

Solution:

- Ensure that the USB 3.0 (and/or USB 2.0) drivers for the host bus and device have been properly and securely installed. You may reinstall to assure proper installation.

Notes:

- When connecting the device to USB 3.0 port in your computer, please be sure that the connection at the host computer is Super Speed USB 3.0 and drivers (if required) are installed; otherwise you may experience slower transfer speed between the host computer and the Commander device.

Notes - Mac OS 10x:

- Commander drives are designed to save electricity and subsequently the wear and tear of the internal hard drive by having the hard drive stop spinning when the Commander is not accessed for a certain amount of time (sleeping mode). Under Mac OS 10 you it might cause an error please ignore the error message as it might take few seconds to start spinning at the designated speed (wake up.)
- You may require upgrading to a higher version of Mac OS if your host computer does not recognize the Commander device when connected via FireWire.
- You must avoid particular characters similar to ^!?\< when coping to FAT 32 volume section.

Troubleshooting for PC WINDOWS based computers

Problem: The computer does not appear to recognize the drive.

Solutions:

- A window should appear, notifying you that a device is connected and/or the Commander HD icon should appear on the “My Computer” folder.
- Your computer’s Minimum requirements may not meet the minimum system requirements as indicated in this Manual. Page 7
- Confirm that the outlet is providing the correct voltage and the electrical power cord is securely attached to both the outlet and the Commander drive. Poor or loose connections can result in loss of power and possible damage to the drive. Ensure that the ON/OFF switch is turned to the ON position.
- If the Commander drive is connected to an outlet via an Uninterrupted Power Supply (battery Backup) or a surge protector, be sure that they provide the correct voltage and they are all switched “ON” and receiving electricity.
- Please review the Manual’s installation procedure in reference to Formatting, Operating Systems and Interfaces you are using to ensure they were properly followed.
- Please check the cable connections as the cables must be properly and securely attached to the computer and hard drive. Ensure that there is a firm connection. It is suggested that the cables be detached and reattached, and that the computer be shut off for 20 seconds and then restarted.
- If a conflict with drivers or extensions exists, contact Rocstor for assistance; email tech support at support@rocstor.com or call technical support department at 888.877.7716.

Problem: The FireWire ports would not mount (work) with Windows 2000

Solution:

- You may require installing Windows 2000 Service pack 4. You may download the Service Pack 4 update for free from the Microsoft website.
<http://www.microsoft.com/Downloads/details.aspx?familyid=1001AAF1-749F-49F4-8010-297BD6CA33A0&displaylang=en>

Problem: The Commander drive is not working fast enough

Solution:

- You may have too many devices connected to your computer (in particular in case of Laptops.) Disconnect some devices and observe if there is an improvement in performance.

Problem: The performance and/or transfer speeds are slow when the Commander drive is connected to my USB port.

Solution:

- USB ports come in different speeds from 12Mbits/s (USB 1.0), 480Mbits/s (USB.2) to up to 5,000Mbits/s (USB 3.0). If the Commander HD is connected to a USB 2.0 or 1.1 port (low speed) or hub, the drive will work slower than if connected to a USB 3.0 port or hub.

Simply: if the USB 3.0 cable is connected (from Commander 3F) to a USB 2.0 connector in your host computer the transfer speed will be reduced to up to 480 Mbit/s (which is the maximum transfer speed of USB 2.0)

Problem: There is no increase in performance when the Commander drive is connected via the USB cable to a USB 3.0 port.

Solution:

- Ensure that the USB 3.0 (and/or USB 2.0) drivers for the host bus and device have been properly and securely installed. You may reinstall to assure proper installation.

Problem: The drive is working slow when connected directly to a USB 3.0 port on your computer

Solution:

- Review the minimum system requirements for your computer to ensure it supports Super Speed USB 3.0.

General Notes:

- When connecting the device to USB 3.0 port in your computer please be sure that the connection at the host computer is High Speed USB 3.0 and drivers (if required) are installed, otherwise you may experience slower transfer speed between the host computer and the Commander device.

Front Lights:

Problem: The front Light does not come ON.

Solutions:

- The Commander device may not be connected to electricity.
- The device switch is in the OFF position.
- The Built-in Power Supply does not work. Contact Rocstor technical support.

Situation: The light is green but it also flickers in Red.

Solutions:

- The Light is OFF when the drive is Reading/Writing; do not turn the device OFF in this situation as you may lose the data being transferred in R/W.
- The light remains Green at normal operation or idle operation.

KNOWLEDGE BASE

Commander 3F Unique Features

- **Built-in power supply**
(No bulky AC adapter necessary.)
Direct Connection to Electricity.

U.S.A. and International Auto-Switch Power Supply.
Uses any standard (certified) computer cable



- Secured by AES-256 Real-Time Hardware Encryption
- The encryption chipset bears certifications from the **NIST** and **FIPS** for a Cryptographic Module
- Authentication: Key-Token



- Carrying case included.



- The Advanced Aluminum Material enclosure performs as a heat sink around the hard drive. The state of the art casing is designed and engineered to maximize heat dissipation.

- The Fan-less enclosure significantly reduces noise and vibration.
- The case should be in an open environment to permit air to flow around the drive. It is normal for the case to become warm when it is being used.
- The Commander series is designed for stackable, horizontal and vertical use.



- Includes all necessary cables and software
- Easy plug-and-play installation (pre-formatted Hard Drive)



- Cross-platform compatibility Mac, Windows, Linux ...
- Designed for horizontal or vertical use
- 2 year limited warranty
- 2 year unlimited toll-free telephone tech support

Specifications

- **Dimensions:** 5.8 x 8.7 x 1.6 inches
14.7 x 22.0 x 4.1 cm
- **Weight:** 2.9 pounds (1.3 kilograms)
- **Transfer rates:** USB 3.0 up to 5,000 Mbits/s;
FireWire up to 800 MB/s; FireWire 400 up to 400
Mbits/s; USB 2.0 up to 480 Mbits/s; or USB 1.1 up
to 12 Mbits/s.



Encryption Technology

One of the most secure and cutting-edge hardware-based encryption chipsets is integrated into the internal circuitry of the Commander lines. The chipset contains features such as Advanced Encryption Standard Algorithm AES-256 bit key strength, and real-time encryption so that there is virtually zero time in encrypting and decrypting the data. While in either CBC or ECB modes, the encryption chipset bears certifications from the National Institute of Standards and Technology (NIST), and FIPS Level 2 for a Cryptographic Module. The Commander is authenticated by a digital key token, which is inserted for authentication, and removed soon after the device is authenticated, and then ready for secure data transfer.



How Does Commander Encrypted External Hard Drives Protect Your Data?

Q: What security technology does Commander external hard drives adopt?

A: Several security schemes are popularly employed to protect data, including:

- Password security without hardware encryption - This basic OS/software solution blocks unauthorized data access by requiring a password. While this may be adequate for a coffee break, this form of security is very easy to bypass.
- Biometric security without hardware encryption - This form of security requires a combination of a unique physical characteristic, such as a fingerprint, retinal scan, or vocal signature. While more secure than simple password security, it can be circumvented too, leaving unencrypted data at risk. Biometric security also requires a substantial hardware investment and additional administrative burden.
- Hardware security—Hardware security is by far the most thorough, cost-effective, and easily implemented form of advanced security.

Rocsecure—Commander external drives use hardware-based security, performed by eNova's X-Wall MX, to provide reliable security for your stored data. Every bit and byte on the hard

drive is strongly encrypted by AES (Advanced Encryption Standard). There is no possibility that clear text will remain on the hard drive.

Q: What is hardware-based encryption?

A: Encryption is a sophisticated mathematical calculation (or algorithm) combining a “secret key” and clear text. The resulting “cipher text” is an unreadable code that can only be decrypted with the original “secret key.” The hardware encryption, performed by eNova X-Wall microchip, delivers significant performance improvement over software encryption, works with every operating system found today, and requires no additional training to use. This encryption methodology protects your valuable data with minimum Total Cost of Ownership (TCO).

Q: How does encryption function?

A: X-Wall MX sits between the PCI Bridge and the device on the SATA interface. It intercepts, interprets, translates, and relays real-time commands and data to and from the disk drives, encrypting the data with AES-256 bit key strength. The following illustration best describes how the security chipset functions.

Q: What is the secure key and why use it?

A: The secure key (or digital key or key token) is a physical key that contains the “secret key” necessary for encryption and decryption operations. The hard drive must be partitioned and formatted using the secure key the first time the hard drive is used. When complete, the entire content of the hard drive is associated with the unique secure key. Only a secure key containing the identical “secret key” can be used for authentication and decryption of the hard drive at power up.

Q: Do I need to establish a separate “encrypted folder” under file directory as required by some software solutions?

A: No. Everything you write to the disk drive is automatically strongly encrypted. There is no need to establish a separate “encrypted folder.”

Q: Does X-Wall MX increase the original file size after encryption?

A: No. AES is a complicated mathematical algorithm that computes the original data with 128 or 256 bit key length. Regardless of the size of the encryption key, the size of data file after encryption remains unchanged.

Q: Are Commander encrypted drives compatible with all disk drive types?

A: Commander encrypted hard drives are compatible with Ultra SATA/eSATA compliant disk drives in real-time performance.

Q: Can Commander external drives work with any operating system?

A: Commander external drives require no device drivers and are independent from all operating systems. A host controller with a USB/SATA mass storage driver typically provided by the OS is required. The only requirement is an Ultra SATA/eSATA compliant disk drive.

Q: How do I know my Commander encrypted external drives are really secured?

A: The AES hardware engine utilized by X-Wall MX has been validated by FIPS (US Federal Information Processing Standard) 140-2 Level 3 Cryptographic Engine for Physical Security and certified by the NIST (National Institute of Standards and Technology) of USA and CSE (Communications Security Establishment) of Canada certified hardware AES (Advanced Encryption Standard) algorithm. To review these certificates, visit the following NIST web links: http://www.enovatech.net/resources/aes_no60.htm#a. These hardware algorithms are certified to provide reliable security; at full strength, it is virtually impossible to access the encrypted data by guessing or deriving the right AES key. Because everything on the disk is encrypted, your data is safe even if attackers try to boot from their own disk, or to move your disk to an unprotected machine.

Q: Can I remove the secure key while my PC is on?

A: Yes, you can remove the secure key for safekeeping after your operating system has fully loaded. Remember that the secure key *must* be used again the next time you power up your system. Note: The above X-WALL product information is property of eNova and is provided for informational purposes only; eNova retains copyright and ownership of all provided material regarding the eNova X-WALL MX.

Encryption Algorithm Overview

The *X-Wall MX* family ASIC (Application Specific Integrated Circuit) is the 7th generation of *X-Wall* Technology. It is engineered specifically to encrypt/decrypt entire SATA hard drive including boot sector and operating system in real-time performance. The cryptographic engine of the *X-Wall MX* is **NIST (National Institute of Standards and Technology) of USA and CSE**

(Communications Security Establishment) of Canada certified hardware **AES** (Advanced Encryption Standard) algorithm.



How does it work?

X-Wall MX, an SATA to SATA cryptographic bridge chip, sits right in between host SATA and the device SATA hard drive, encrypting entire SATA drive with wire speed performance while providing up to 256-bit AES hardware strength.

System performance with *X-Wall MX* engaged is unaffected. *X-Wall MX* can be operated with SATA1.0a & 2.0 compliant disk drives with a sustained throughput of 150MB/sec. The performance-optimized AES hardware engine performs all encryption and decryption. There are no extra software components, eliminating entirely the memory and interrupt overheads. *X-Wall MX* requires no device driver and is independent from and invisible to all known Operating Systems including embedded OS. As long as the drive is SATA1.0a & 2.0 compliant, *X-Wall MX* will work in the system. Once authenticated, its operation is completely transparent to all users. There is no complex GUI involved therefore your regular computing behavior is unchanged.

Key Management

Commander Key Management with *X-Wall M* includes PIN/Password through Pre-boot authentication a USB type external key token.

Key Benefits

- Offers wire speed performance at sustained 150MB/sec on all encryption strengths
- Operating System independent (No software installations required)
- FIPS (US Federal Information Processing Standard) 140-2 Level 3 Cryptographic Engine validated for Physical Security
- Provides iron-clad security through hardware-based NIST & CSE certified cryptographic AES engine
- Simplify engineering design for security targets

As the entire SATA hard drive is encrypted, there is no possibility of any secret being left unprotected on the drive, including password and "Secret Key." In an *X-Wall MX* protected system (drive), there is no simple way to read the data without the right "Secret Key." Only YOU have the right Key to unlock your data.

The *X-Wall MX* technology is compatible with all system designs incorporating SATA hard drive technologies

Features

- Power-On-Self-Test (POST) ability to ensure product reliability
- Versatile Key Management through either serial interface or built-in API (Application Programming Interface)
- 100% hardware AES (ECB mode) cryptographic engine producing a sustained 150MB/sec wire speed performance
- 80-pin TQFP small form factor
- RoHS & Lead-free compliant
- Very low power consumption at less than 350mW at 1.8V under constant burst mode

System Requirement

- All Microsoft Windows Operating Systems
- Linux OS with SATA support
- All embedded OS with SATA support
- SATA1.0a & 2.0 compliant hard drive

Introductions: Interfaces (ports) and Cables

FireWire is Apple Inc.'s brand name for the IEEE **1394** interface (although the 1394 standard also defines a backplane interface). FireWire is also known as **i.LINK** (Sony's name) and **DV** (Panasonic's name, not to be confused with DV camcorder tapes). It is a serial bus interface standard for high-speed communications and isochronous real-time data transfer, frequently used in a personal computer and digital audio / digital video.

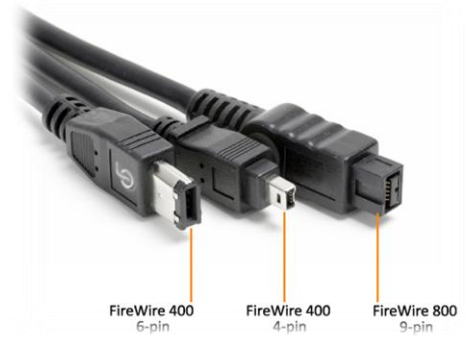

Standards and versions

FireWire 400 (IEEE 1394) 6-Pin connector can transfer data between devices at 100, 200, or 400 Mbits/s half-duplex data rates (the actual transfer rates are 98.304, 196.608, and 393.216 Mbits/s, i.e. 12.288, 24.576 and 49.152 megabytes per second respectively). These different transfer modes are commonly referred to as S100, S200, and S400.



Cable length is limited to 14.8 ft (4.5 meters), although up to 16 cables can be daisy-chained using active repeaters, external hubs, or internal hubs often present in FireWire equipment. The S400 standard limits any configuration's maximum cable length to 230ft (72 meters.) The 6-pin connector is commonly found on desktop computers and can supply the connected device with power.

The 6-pin powered connector adds power output to support external devices. Typically a device can pull about 7 to 8 watts from the port. However, the voltage varies significantly from different devices. Voltage is specified as unregulated and should nominally be about 25 volts (range 24 to 30). Apple's implementation on laptops is typically related to battery power and can be as low as 9 V but more likely about 12 V.

FireWire 400 (IEEE 1394a)

1394a also standardized the 4 pin connector already widely in use. The 4-pin version is used on many consumer devices such as camcorders, some laptops and other small FireWire devices. Though fully data compatible with 6-pin interfaces, it lacks power connectors.

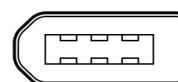

FireWire 800 (IEEE 1394b) 9-pin FireWire 800/3200 (IEEE 1394b) connector was introduced commercially by Apple in 2003. This newer 1394 specification (1394**b**) and corresponding products allow a transfer rate of 786.432 Mbits/sec full-duplex via a new encoding scheme termed beta mode. It is backwards compatible to the slower rates and 6-pin connectors of FireWire 400. However, while the IEEE 1394**a** and IEEE 1394**b** standards are compatible, the FireWire 800's connector is different from FireWire 400's connector, making the two cables incompatible. An adapter or adapter cable, purchased from a local electronics store allows the connection of older devices to the newer port.



The full IEEE 1394b specification supports data rates up to 3200 Mbits/sec over beta-mode optical connections up to 320 Ft (100 meters) in length.

Universal Serial Bus (USB) is a serial bus standard to interface devices. USB was designed to allow peripherals to be connected using a single standardized interface socket and to improve Plug-and-play capabilities by allowing devices to be connected and disconnected without rebooting the computer (hot-swapping). Other convenient features include providing power to low-consumption devices without the need for an external power supply and allowing many devices to be used without requiring manufacturer specific, individual device drivers to be installed.



USB can connect computer peripherals such as external hard drives storage devices, keyboards, PDAs, scanners, digital cameras, printers, personal media players and flash drives. For many of those devices USB has become the standard connection method.

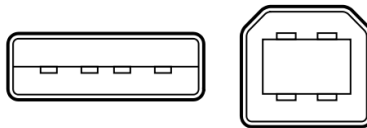

USB supports four data transfer rates:

- USB 3.0: A Super-Speed (USB 3.0) rate of up to 5,000 Mbits/s (1GB/3.3sec)
- USB 2.0: A Hi-Speed rate of 480 Mbits/s (60 MB/s). All Rocstor devices are integrated with USB 2.0, *Hi-Speed*.
- USB 1.1: A **Full Speed** rate of 12 Mbits/s (1.5 MB/s). All USB Hubs support Full Speed.
- USB 1.0: A **Low Speed** rate of 1.5 Mbits/s (187 KB/s)

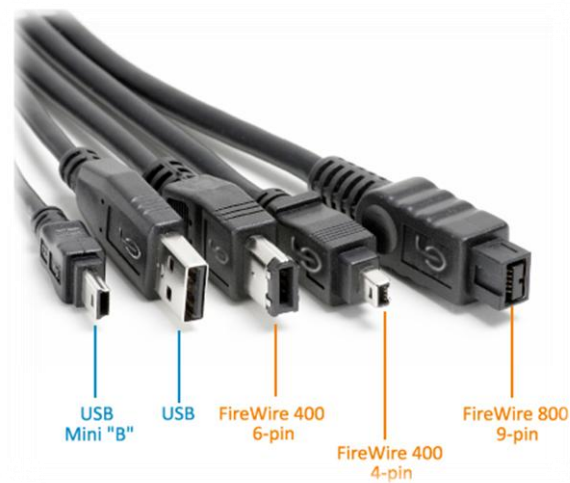

Compassion Chart:

| | Raw Bandwidth (Mbits/s) | Transfer Speed (Mbits/s) | Max. Cable Length Feet (meters) | Power Provided | Device per channel |
|---------------------------------------|----------------------------|-----------------------------|-----------------------------------|----------------|---------------------------|
| SAS | 3000 | 375 | 26 Ft (8 m) | No | 4 |
| eSATA | 3000 | 375 | 6.5 Ft (2 m) | No | 1 (15 W/ port multiplier) |
| SATA 300 | 3000 | 375 | 3.3 Ft (1 m) | No | 1 per line |
| SATA 150 | 1500 | 187.5 | 3.3 Ft (1 m) | No | 1 per line |
| PATA (133) | 1064 | 133 | 18 inches (0.46 meters) | No | 2 |
| FireWire 3200 | 3144 | 393 | 100; (Cables available for 100m+) | 12–25 V, 15 W | 63 |
| FireWire 800 | 786 | 98.25 | 100 [11] m | 12–25 V, 15 W | 63 |
| FireWire 400 | 393 | 49.13 | 15 Ft (4.5 m) | 12–25 V, 15 W | 63 |
| USB 2.0 | 480 | 60 | 5 [14] m | 5 V, 2.5 W | 127 |
| USB 3.0 | 4800 | 600 | TBD | 5 V, 2.5 W | 127 |
| Ultra -320 SCSI | 2560 | 320 | 39 Ft (12 m) | No | 16 |
| Fiber Channel Over Copper Cable | 4000 | 400 | 39 Ft (12 m) | No | 16777216 with switches |
| Fiber Channel Over Fiber | 10520 | 2000 | 6.5- 164000 Ft (2–50000 m) | No | 16777216 with switches |
| Infiniband | | | > 32 Ft (>10 m) Copper | | 1 with point to point |
| 12x quad-rate | 120000 | 12000 | <32,800 Ft (<10000 m) Fiber | No | Many W/switched Fabric |

Introductions: Formatting

File Allocation Table (FAT)

FAT is a file system developed by Microsoft for MS-DOS and is the primary file system for consumer versions of Microsoft Windows.

The FAT file system is relatively uncomplicated and is supported by virtually all existing operating systems for personal computers. This makes it an ideal format for hard drives and other storage devices and a convenient way of sharing data between disparate operating systems installed on the same computer (a dual boot environment).

FAT 32 is a disk formatting scheme which allows a maximum file size of 4 GB. Larger files require another formatting type such as HFS+ or NTFS.

Microsoft's Scan-Disk utility, included with Windows 95/98, places a volume limit of 127.53 gigabytes.

FAT 32 was introduced with Windows 95 OSR2. Windows 98 introduced a utility to convert existing hard disks from FAT16 to FAT32 without loss of data. In the NT line, native support for FAT32 arrived in Windows 2000.

Windows 2000 and Windows XP can read and write to FAT32 file systems of any size, but the format program included in Windows 2000 and higher can only create FAT32 file systems of 32 GB or less. This limitation is by design and was imposed because many tasks on very large FAT32 files become slow and inefficient when file systems exceed 32GB. This limitation can be bypassed when using the Windows command line Format utility or by using third-party formatting utilities.

The maximum possible size for a file on a FAT32 volume is 4 GB minus 1 byte. Video capture and editing applications and some other software can easily exceed this limit.

Until mid-2006, those who run dual boot systems or who move external data drives between computers with different operating systems had little choice but to stick with FAT32. Since then, full support for NTFS has become available in Linux and many other operating systems, by installing the FUSE library (on Linux) together with the NTFS-3G application. Data exchange is also possible between Windows and Linux by using the Linux-native ext2 or ext3 file systems through the use of external drivers for Windows, such as ext2 IFS. However, Windows cannot boot from ext2 or ext3 partitions.

HFS Plus or HFS+

This is a file system developed by Apple Inc. to replace their Hierarchical File System (HFS) as the primary file system used in Macintosh computers (or other systems running Mac OS). It is also one of the formats used by the iPod digital music player. HFS Plus is also referred to as **Mac OS Extended** (or, erroneously, “HFS Extended”), where its predecessor, HFS is also referred to as *Mac OS Standard* (or, erroneously, as “HFS Standard”). During development, Apple referred to this file system with the codename *Sequoia*.

HFS Plus is an improved version of HFS, supporting much larger files (block addresses are 32-bit length instead of 16-bit) and using Unicode (instead of Mac OS Roman or any of several other character sets) for naming the items (files, folders). Names were normalized to a form very nearly the same as NFD (there are some minor differences derived from the fact that the HFS Plus format was finalized before Unicode had standardized the NFD format). HFS Plus permits filenames up to 255 UTF-16 characters in length, and n-forked files similar to NTFS, though almost no software takes advantage of forks other than the data fork and resource fork. HFS Plus also uses a full 32-bit allocation mapping table, rather than HFS’s 16 bits. This was a serious limitation of HFS, meaning that no disk could support more than 65,536 allocation blocks under HFS. When disks were small, this was of little consequence, but as larger-capacity drives became available, it meant that the smallest amount of space that any file could occupy (a single allocation block) became excessively large, wasting significant amounts of space. For example, on a 1 GB disk, the allocation block size under HFS is 16 KB, so even a 1 byte file would take up 16 KB of disk space.

HFS Plus volumes are divided into sectors (called logical blocks in HFS), that are usually 512 bytes in size. These sectors are then grouped together into allocation blocks which can contain one or more sectors. The number of allocation blocks depends on the total size of the volume. HFS Plus uses a larger value to address allocation blocks than HFS, 32 bits rather than 16 bits. This means it can access 4,294,967,296 ($=2^{32}$) allocation blocks rather than the 65,536 ($=2^{16}$) allocation blocks available to HFS.

LIMITED WARRANTY

This Limited Warranty is provided by Rocstorage, Inc. (hereinafter: Rocstor) for all lines of products.

General Terms

EXCEPT AS EXPRESSLY SET FORTH IN THIS LIMITED WARRANTY, ROCSTOR MAKES NO OTHER WARRANTIES OR CONDITIONS, EXPRESS OR IMPLIED, INCLUDING ANY IMPLIED WARRANTIES OF MERCHANTABILITY AND FITNESS FOR A PARTICULAR PURPOSE. ROCSTOR EXPRESSLY DISCLAIMS ALL WARRANTIES AND CONDITIONS NOT STATED IN THIS LIMITED WARRANTY. ANY IMPLIED WARRANTIES THAT MAY BE IMPOSED BY LAW ARE LIMITED IN DURATION TO THE LIMITED WARRANTY PERIOD. SOME STATES OR COUNTRIES DO NOT ALLOW A LIMITATION ON HOW LONG AN IMPLIED WARRANTY LASTS OR THE EXCLUSION OR LIMITATION OF INCIDENTAL OR CONSEQUENTIAL DAMAGES FOR CONSUMER PRODUCTS. IN SUCH STATES OR COUNTRIES, SOME EXCLUSIONS OR LIMITATIONS OF THIS LIMITED WARRANTY MAY NOT APPLY TO YOU.

This Limited Warranty applies to the Rocstor branded hardware products sold by or leased from Rocstorage, Inc., its worldwide subsidiaries, affiliates, authorized resellers, or country distributors (collectively referred to in this Limited Warranty as “Rocstor”) with this Limited Warranty. This Limited Warranty is applicable in all countries and may be enforced in any country where Rocstor or its authorized service providers offer warranty service subject to the terms and conditions set forth in this Limited Warranty. However, warranty service availability and response times may vary from country to country and may also be subject to registration requirements in the country of purchase.

Rocstor warrants that the Rocstor hardware product and all the internal components of the product that you have purchased or leased from Rocstor are free from defects in materials or workmanship under normal use during the Limited Warranty Period. The Limited Warranty Period starts on the date of purchase or lease from Rocstor. Your dated sales or delivery receipt, showing the date of purchase or lease of the product, is your proof of the purchase or lease date. You may be required to provide proof of purchase or lease as a condition of receiving warranty service. You are entitled to warranty service according to the terms and conditions of this document if a repair to your Rocstor branded hardware is required within the Limited Warranty Period. This Limited Warranty extends only to the original purchaser or lessee of this Rocstor branded product and is not transferable to anyone who obtains ownership of the Rocstor branded product from the original purchaser or lessee.

Rocstor products are manufactured using new materials or new and used materials equivalent to new in performance and reliability. Spare parts may be new or equivalent to new. Spare parts are warranted to be free from defects in material or workmanship for thirty (30) days or for the remainder of the Limited Warranty Period of the Rocstor hardware product in which they are installed, whichever is longer.

Rocstor’s Obligation under the Limited Warranty

During the Limited Warranty Period, Rocstor will repair or replace the defective component parts or the hardware product. All component parts or hardware products removed under this Limited Warranty become the property of Rocstor. The replacement part or product takes on either the Limited Warranty status of the removed part or product or the thirty (30) day limited warranty of the spare part. In the unlikely event that your Rocstor product has a recurring failure, Rocstor, at its discretion, may elect to provide you with a replacement unit of Rocstor’s choosing that is at least equivalent to your Rocstor branded product in hardware performance. Rocstor reserves the right to elect, at its sole discretion, to give you a refund of your purchase price or lease payments (less interest) instead of a replacement. This is your exclusive remedy for defective products. The original Limited Warranty is not extended when the product, or a part of the product, is repaired or replaced during the Limited Warranty period. Rocstor shall not be responsible or liable for backing up any data that is on a drive being returned for service

YOU SHOULD MAKE PERIODIC BACKUP COPIES OF THE DATA STORED ON YOUR HARD DRIVE OR OTHER STORAGE DEVICES AS A PRECAUTION AGAINST POSSIBLE FAILURES, ALTERATION, OR LOSS OF THE DATA. BEFORE RETURNING ANY UNIT FOR SERVICE, BE SURE TO BACK UP DATA AND REMOVE ANY CONFIDENTIAL, PROPRIETARY, OR PERSONAL INFORMATION. ROCSTOR IS NOT RESPONSIBLE FOR DAMAGE TO OR LOSS OF ANY PROGRAMS, DATA, OR REMOVABLE STORAGE MEDIA. ROCSTOR IS NOT RESPONSIBLE FOR THE RESTORATION OR REINSTALLATION OF ANY PROGRAMS OR DATA OTHER THAN SOFTWARE INSTALLED BY ROCSTOR WHEN THE PRODUCT WAS MANUFACTURED.

Rocstor does not warrant that the operation of this product will be uninterrupted or error-free. Rocstor is not responsible for damage that occurs as a result of your failure to follow the instructions that came with the Rocstor branded product.

This Limited Warranty does not apply to expendable parts. This Limited Warranty does not extend to any product from which the serial number has been removed or that has been damaged or rendered defective (a) as a result of accident, misuse, abuse, or other external causes; (b) by operation outside the usage parameters stated in the user documentation that shipped with the product and/or posted on the Rocstor website; (c) by the use of parts not manufactured or sold by Rocstor; (d) as a result of normal wear; or (e) by modification or service by anyone other than (i) Rocstor, (ii) a Rocstor authorized service provider, or (iii) your own installation of end-user replaceable Rocstor or Rocstor approved parts if available for your product in the servicing country.

These terms and conditions constitute the complete and exclusive limited warranty agreement between Rocstor and you regarding the Rocstor branded product you have purchased or leased. These terms and conditions supersede any prior agreements or representations including representations made in Rocstor sales literature or advice given to you by Rocstor or an agent or employee of Rocstor-that may have been made in connection with your purchase or lease of the Rocstor branded product. No change to the conditions of this Limited Warranty is valid unless it is made in writing and signed by an authorized representative of Rocstor.

Buyer's Obligation under the Warranty

The person requesting coverage under this warranty shall prove that he or she is the original purchaser and declares that the product has not been sold, leased, bartered or otherwise changed possession. **The purchaser shall frequently backup the Commander hard drive and backup the data immediately prior to returning the drive for warranty service.**

The buyer must notify Rocstor and show proof of notification, through any reasonable means of communication. See Full Street address email address and toll free phone numbers below or updated contact information are available on Rocstor.com website. The notification shall identify any defect, malfunction, or nonconformity promptly upon discovery. Rocstor will acknowledge receipt of the communication and issue a Return Merchandise Authorization (RMA) code. The buyer is obligated to securely and safely package(s) the product, preferably in the original packing materials, WITH THE RMA number, and deliver it together with a copy of the original purchase receipt and a description of the problem to the Rocstor home office. Buyer is responsible for the product until it is received by Rocstor. It is recommended that the product be insured during transportation by the sender. You must prepay any shipping charges, taxes, or duties associated with transportation of the product. In addition, you are responsible for insuring any product shipped or returned for service. You assume risk of loss during shipping.

Limitation of damages (Liability)

IF YOUR ROCSTOR BRANDED HARDWARE PRODUCT FAILS TO WORK AS WARRANTED ABOVE, THE ORIGINAL PURCHASER'S SOLE AND EXCLUSIVE REMEDY SHALL BE REPAIR OR REPLACEMENT. ROCSTOR'S MAXIMUM LIABILITY UNDER THIS LIMITED WARRANTY IS EXPRESSLY LIMITED TO THE LESSER OF THE PRICE YOU HAVE PAID FOR THE PRODUCT OR THE COST OF REPAIR OR REPLACEMENT OF ANY ROCSTOR HARDWARE COMPONENTS THAT

MALFUNCTION IN CONDITIONS OF NORMAL USE. ROCSTOR IS NOT LIABLE FOR ANY DAMAGE TO ANY OTHER PRODUCT CONNECTED TO A ROCSTOR PRODUCT.

Limitation on Consequential Damages

ROCSTOR IS NOT LIABLE FOR ANY DAMAGES CAUSED BY THE PRODUCT OR THE FAILURE OF THE PRODUCT TO PERFORM, INCLUDING ANY LOST PROFITS OR SAVINGS OR SPECIAL, INCIDENTAL OR CONSEQUENTIAL DAMAGES. ROCSTOR IS NOT LIABLE FOR ANY CLAIM MADE BY A THIRD PARTY OR MADE BY YOU FOR A THIRD PARTY. THIS LIMITATION OF LIABILITY ALSO APPLIES WHETHER DAMAGES ARE SOUGHT OR A CLAIM IS MADE UNDER THIS LIMITED WARRANTY OR AS A TORT CLAIM (INCLUDING NEGLIGENCE AND STRICT PRODUCT LIABILITY), A CONTRACT CLAIM OR ANY OTHER CLAIM. THIS LIMITATION OF LIABILITY CANNOT BE WAIVED OR AMENDED BY ANY PERSON. THIS LIMITATION OF LIABILITY WILL BE EFFECTIVE EVEN IF YOU HAVE ADVISED ROCSTOR OR AN AUTHORIZED REPRESENTATIVE OF ROCSTOR OF THE POSSIBILITY OF ANY SUCH DAMAGES.

THIS LIMITED WARRANTY GIVES YOU SPECIFIC LEGAL RIGHTS. YOU MAY ALSO HAVE OTHER RIGHTS THAT MAY VARY FROM STATE TO STATE OR FROM COUNTRY TO COUNTRY. YOU ARE ADVISED TO CONSULT APPLICABLE STATE OR COUNTRY LAWS FOR A FULL DETERMINATION OF YOUR RIGHTS.

Disclaimer

We accept no liability for any loss of data, damages and the inability of Rocstor products to work with any third party equipment. Nor can Rocstor accept any liability or responsibility for software or third party hardware products.

Limited Warranty Period

The limited warranty period for Commander 3F is two (2) Years Parts and Labor. This Limited Warranty extends only to the original purchaser or lessee of this Rocstor branded product and is not transferable to anyone who obtains ownership of the Rocstor branded product from the original purchaser or lessee.

Types of Limited Warranty Service

Your Rocstor Limited Warranty consists of repair or replacement of defective parts, including hard drives identified by Rocstor Support Organization as “pre-failure.”

Carry-in Limited Warranty Service Available Monday - Friday

Under the terms of carry-in service, you may be required to deliver your Rocstor product to the Rocstor Service Center or an authorized service location for warranty repair. You must prepay any shipping charges, taxes or duties associated with transportation of the product. In addition, you are responsible for insuring any product shipped or returned for service. You assume risk of loss during shipping.

YOU SHOULD MAKE PERIODIC BACKUP COPIES OF THE DATA STORED ON YOUR HARD DRIVE OR OTHER STORAGE DEVICES AS A PRECAUTION AGAINST POSSIBLE FAILURES, ALTERATION OR LOSS OF THE DATA. BEFORE RETURNING ANY UNIT FOR SERVICE, BE SURE TO BACK UP DATA AND REMOVE ANY CONFIDENTIAL, PROPRIETARY OR PERSONAL INFORMATION. ROCSTORAGE IS NOT RESPONSIBLE FOR DAMAGE TO OR LOSS OF ANY PROGRAMS, DATA OR REMOVABLE STORAGE MEDIA. ROCSTORAGE IS NOT RESPONSIBLE FOR THE RESTORATION OR REINSTALLATION OF ANY PROGRAMS OR DATA OTHER THAN SOFTWARE INSTALLED BY ROCSTORAGE WHEN THE PRODUCT WAS MANUFACTURED.

Rocstorage shall not be responsible or liable for backing up any data that is on a drive being returned for service. Expect that all data on the drive will be destroyed and not retrievable when returned for warranty service.

Rocstor Replaceable Parts Program

Where available, the Rocstor Replaceable Parts program ships approved replacement parts directly to you to fulfill your warranty. This will save considerable repair time. After you call the Rocstor Technical Support Center at **888.877.8777** a replaceable part can be sent directly to you. Once the part arrives, call the Rocstor Technical Support Center. A technician will assist you over the phone to ensure that the installation is quick and easy.

Service Upgrades

Rocstor offers extra coverage for your product. For information on service upgrades, visit www.rocstor.com. Service upgrades purchased in one country are not transferable to another country.

Capacity Disclaimer

Actual accessible hard drive capacity will indicate up to 10% lower than stated under different Operating Systems and formatting.

The storage volume is measured in total bytes before formatting. References to round numbers of gigabytes or terabytes are an approximation only. For example, a disk drive labeled as having 500GB (Gigabytes) has space for approximately 500,000,000 bytes before formatting. After formatting, the drive capacity is reduced by about 5% to 10% depending on the operating system and formatting used or "1GB = 1,000,000,000 bytes.

Options and Software

The Limited Warranty terms and conditions for Rocstor options are as indicated in the Limited Warranty applicable to Rocstor options. **ROCSTOR DOES NOT WARRANTY SOFTWARE PRODUCTS, INCLUDING ANY SOFTWARE PRODUCTS OR THE OPERATING SYSTEM PREINSTALLED BY ROCSTOR.** Rocstor's only obligations with respect to software distributed by Rocstor under the Rocstor brand name are set forth in the applicable end-user license or program license agreement. Non-Rocstor hardware and software products are provided "AS IS" and without any Warranty. However, non-Rocstor manufacturers, suppliers or publishers may provide their own warranties directly to you.

The data stored in Rocstor and Rocsecure storage product lines are not guaranteed by Rocstor (or the hard disk manufacturer.) We are not responsible for any loss of data. Always back up data regularly

TECHNICAL SUPPORT

Software Technical Support

Software technical support is defined as assistance with questions and issues about the software that was either preinstalled by Rocstor on the Rocstor branded product or that was included with the Rocstor branded product at the time of your purchase or lease of the product. Technical support for software is available for the first ninety (90) days from date of product purchase or lease. Your dated sales or delivery receipt, showing the date of purchase or lease of the product, is your proof of the purchase or lease date. You may be required to provide proof of purchase or lease as a condition of receiving software technical support. After the first ninety (90) days, technical support for software that was either preinstalled by Rocstor on the Rocstor branded product or included with the Rocstor branded product at the time of your purchase or lease of the product is available for a fee.

WARNING: The individual user should take care to determine prior to use whether this device is suitable, adequate or safe for the use intended. Since individual applications are subject to great variation, the manufacturer

“Rocstor” makes no representation or warranty as to the suitability or fitness of these devices for any specific application.

Technical Support

All Rocstor hard drives are backed by free telephone technical support for two (2) years from the date of purchase. Please register your product with Rocstor. To register, fill in the Limited Warranty Registration form in the Support tab at www.rocstor.com.

Free telephone technical support is available weekdays from 9 AM until 6 PM Pacific Standard Time. Customers in the United States and Canada can call toll-free: **(888) 877-8777**; all others must call **(818) 449-2000**.

When calling for support, please have the product’s serial number (printed on the label on the bottom of the drive) and system hardware information available.

Trademarks Acknowledgements

© 2012, Rocstorage, Inc; acknowledges the following trademarks for company names or products mentioned within the Rocstor site, portal pages and articles/text/manuals:

Rocstor, Rocsecure and Rocpower are registered trademarks of Rocstorage, Inc. Commander, Rocport, Rocbit, Rocsafe ... are the trademarks of Rocstorage, Inc. "store your future", "secure your future" and "power your future" are the slogan marks of Rocstorage, Inc.

Apple, the Apple logo, Mac, Power Macintosh, FireWire, and Mac Pro, Leopard, Snow Leopard ... are trademarks of Apple Computer, Inc. in the United States and other countries.

Microsoft, MS-DOS, Windows CE, Windows NT, Windows 98, Soft Windows, Vista, Windows 7 ... are registered trademarks of Microsoft Corporation in the United States and other countries.

Intel, Itanium, Pentium XXX, Celeron, and Xeon MMX ... are registered U.S. trademarks of Intel Corporation or its subsidiaries in the United States and other countries.

This product is (may also be) integrated with SATA hard drives from the following manufactures: Seagate, Samsung, Western Digital, Hitachi, Toshiba, Fujitsu ...

All other names are trademarks of their respective companies.

Rocstor wishes to acknowledge the use of tables, charts, graphs and texts from the Wikipedia website.

© 2000 - 2012

Copyrights

© 2012 Rocstorage, Inc. This Manual is protected by United States copyright law and may **not** be reproduced, distributed, transmitted, displayed, published or broadcast without the prior written permission of Rocstorage, Inc. You may not alter or remove any trademark, copyright or other notice from copies of this Manual.



Designed, integrated and assembled by Rocstor in the U.S.A. using domestic and/or foreign components.

Rocstor is a California Company; U.S.A.

Contact Information

Corporate Headquarters

8130 Remmet Avenue
Canoga Park, CA 91304-4129
Office: +1 (818) 449-2000
Fax: +1 (818) 884-8777
Email: info@Rocstor.com

Technical Support / RMA

Tel: (888) 877-7716 (USA and Canada)
Tel: +1 (818) 449-2000 (Domestic and Internationals)
Fax: +1 (818) 884-8777
Hours: 9:00 am - 5:00 pm PST
Mon - Fri (excluding holidays)
Email: support@Rocstor.com

Sales Info

Hours: 8:00 am - 5:00 pm PST
Mon - Fri (excluding holidays)
Email: sales@Rocstor.com
Tel: (888) 877-7716
Fax: (818) 884-8777

Corporate, Government and Academic Customers

Our Corporate Sales Team's goal is to help our U.S.A. and Canadian customers find a storage solution that best serves their needs. We will help you determine your best purchasing options. For more information please contact the appropriate department below or call us at +1 (888) 877-7716

General sales information: sales@Rocstor.com
Corporate sales information: corporate_sales@Rocstor.com
Educational sales information: academic_sales@Rocstor.com
Federal, State & Local government sales information: government_sales@Rocstor.com

Resellers/Business Development/OEM Partners

All Channel National and International Resellers, VARs, Consultants ... contact Rocstor Channel Sales:
In U.S., call: 888.877.7716
Out of USA call +1.818.449.2000
Email: reseller_info@Rocstor.com



Available in Black

Thank you for purchasing Commander 3F

Rocstor

Ver.0726K