

NITECORE® 奈特科尔 EMR10

警告

使用前请仔细阅读使用说明。
本品并非玩具，仅供成人使用。

产品介绍

EMR10 专为户外作业、野营、钓鱼、徒步等户外活动而设计。

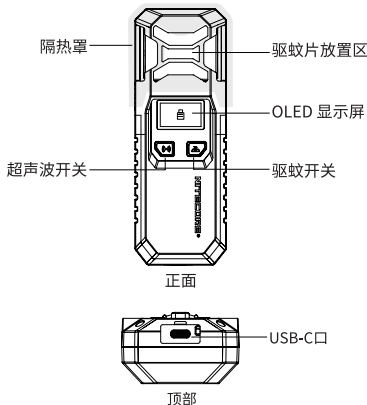

产品参数

输入电压	USB-C:5V-2.4A 9V-2A (18W 最大)
输出电压	USB-C:5V-2.4A 9V-2A 12V-1.5A (18W 最大)
额定容量	10000mAh 36Wh (最大)
超声波频率	25KHz, 40KHz
加热温度	125°C (257°F) (最高)
模式	室内模式: 10m² 保护区域 户外模式: 20m² 保护区域
尺寸	167mm x 59.5mm x 33.5mm (6.6" x 2.3" x 1.3")
重量	149g±5g (5.26oz±0.1oz) (不含配件)
配件	隔热罩、USB 充电线、驱蚊片 x10、NITECORE 21700 锂电池 (NL2150500mAh) x2 (选配)
供电	1-2 节 21700 锂电池, 高达 12 小时长效防护
防护等级	IPX5

装入电池

- 滑动 EMR10 底部电池盖打开, 打开电池背盖。
- 将电池按照指示放入, 反装电池将不能工作。
- 盖上背盖, 滑动电池盖开关锁定。

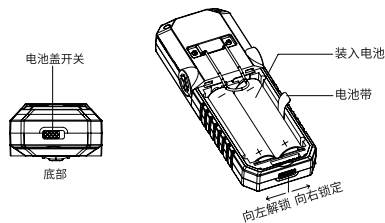

充电:

连接电源:

把 USB-C 充电线一端连至本品 USB-C 接口, 另一端接上 USB 适配器、移动电源或其他 USB 供电设备。(输入: 5V-2A 9V-2A)

注: 在充电过程中, 可开启驱蚊及超声波功能。

操作说明

驱蚊

- 开启: 关闭状态下, 长按驱蚊开关即开启驱蚊功能, 指示灯变为绿色。
- 关闭: 开启状态下, 长按驱蚊开关即关闭驱蚊功能, 指示灯熄灭。
- 室内模式 / 户外模式切换: 开启驱蚊功能状态下, 短按驱蚊开关可切换。

超声波

- 开启: 关闭状态下, 长按超声波开关开启超声波功能, 开关指示灯变为绿色。
- 关闭: 开启状态下, 长按超声波开关关闭超声波功能, 开关指示灯熄灭。

注: 超声波 (大于 20,000Hz) 对人类几乎无声。

锁定 / 解锁

- 锁定: 在没有开启驱蚊与超声波功能时, 双击驱蚊开关, 进入锁定模式。驱蚊与超声波功能禁用。
- 解锁: 锁定状态下, 双击驱蚊开关, 解除锁定, 驱蚊与超声波功能恢复。

休眠功能

若 USB-C 口没有使用且驱蚊功能和超声波功能没有开启, EMR10 会在 30S 后进入休眠状态。此时 OLED 显示屏关闭; 单击任一按键, OLED 显示屏显示电量。

多功能 OLED 显示屏

- 开启驱蚊功能或超声波功能后, OLED 显示屏会显示当前选择功能、模式、可用时间等信息。
- 当 EMR10 处于正常充电状态, OLED 显示屏会显示当前充电功率、当前电池百分比等信息。
- 当 EMR10 处于正常输出状态, OLED 显示屏会显示当前输出功率、剩余可用时间等信息。

使用 EMR10

- 关闭状态下, 取 1 片驱蚊片插至驱蚊片放置区上。
- 长按驱蚊开关, 开启驱蚊功能。
- 10 分钟后即可建立保护区域。
- 使用完毕后, 长按驱蚊开关即关闭, 让其进行完全冷却才可存储。

注: 奈特科尔驱蚊片尺寸 34mm x 48mm 功效最长可达 6 小时 / 片

替换驱蚊片

请确保 EMR10 已经关闭并且冷却, 插入新的驱蚊片将使用过的驱蚊片推出。

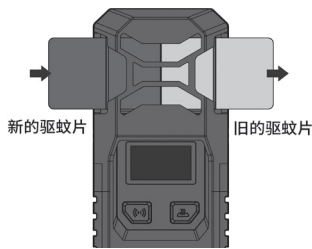

放置 EMR10

- 有风状态, 请将 EMR10 放在驱蚊区域的上风处。
- 使用过程中请不要覆盖 EMR10。
- 如果驱蚊区域面积过大, 建议多个 EMR10 一起使用。

给其他设备充电

USB 输出功能: EMR10 具有 USB 输出功能, 可作为移动电源为外部 USB 充电设备供电。

连接外部设备: 把 USB-C 充电线一端连至本品输出接口, 另一端接上充电设备, 即可对设备进行充电。

注: 放电过程中, 若电池电压过低会自动关闭输出以保护电池。

保存和运输

- 本产品在不使用时, 请存储在干燥的室温环境中。
- 本产品存储期间应取出电池单独存储。

注意事项

- 本品适用人群为 18 岁以上成年人, 请远离儿童。
- 为了减少烫伤风险, 当在儿童附近使用本品时, 需要进行密切地监护。
- 请勿将本品放置在水中。
- 请勿将手指、金属或者其他外来物体放入本品中。
- 请勿在密闭的空间中使用本品。
- 如果发现电池有任何泄漏、异味或变形, 应立即停止使用并将其安全处理。
- 建议使用 NITECORE 奈特科尔电池或其他有安全认证的电池产品。
- 不要让本产品长时间处于高于 60 摄氏度的环境中。
- 切勿擅自拆卸、组装或改装本品, 可能会导致保修服务失效, 详情请查看保固条款。

- 在使用驱蚊功能时, 请安装隔热罩, 以防高温烫伤。
- 使用双节 21700 锂电池时, 请尽量使用两节相同容量且两节电池电压相差不超过 0.1V 的 21700 锂电池, 以防电池或电路损坏。

保固服务

NITECORE® 产品拥有售后保固服务。在购买本产品的 15 天内, 如果有任何质量问题均可向经销商要求免费更换。在购买本产品的 12 个月内享受免费保固服务。在超过 12 个月免费保固期后, 厂家将收取相应的材料费以及快递费。

本保固规则不适用于以下情况:

- 人为破坏, 拆解, 改装本产品。
 - 错误操作导致产品损坏。
- 如对奈特科尔产品有任何疑问, 欢迎联系当地的代理商或发邮件到 4008869828@nitecore.cn
- ※ 本说明书中出现的商标及其产品图片版权属于其合法持有人, 此处仅作参考。
- ※ 本说明书的所有图片、陈述及文字信息仅供参考, 请以官网 www.nitecore.cn 实际信息为准。广州希脉创新科技有限公司拥有对说明书内容的最终解释权 and 修改权。

了解 NITECORE 奈特科尔最新动态, 欢迎关注:

@NITECORE 奈特科尔

@NITECORE 奈特科尔



广州希脉创新科技有限公司

咨询热线: +86-20-83862000

销售邮箱: info@nitecore.com

网址: www.nitecore.cn

地址: 广东省广州市天河区高普路 1021 号 5 楼 6355 号

邮编: 510653



EMR19071022

NITECORE®

KEEP INNOVATING

EMR10 Portable Electronic Multipurpose Repeller

⚠️IMPORTANT

Read all instructions before use.
This product is intended for adult use only. This product is not a toy.

Product Introduction

The EMR10 is specially designed for outdoor activities, such as outdoor work, camping, fishing, trekking and more.

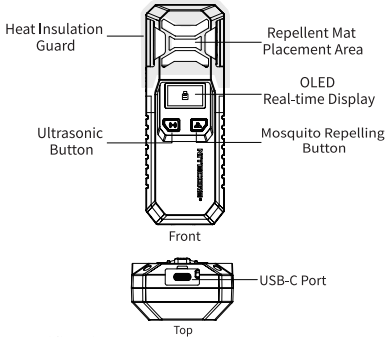

Specifications

Input	5V-2.4A / 9V-2A (18W MAX)
Output	5V-2.4A / 9V-2A / 12V-1.5A (18W MAX)
Rated Capacity	10,000mAh 36Wh MAX
Ultrasonic Frequency	25kHz, 40kHz
Heating Temperature	125°C / 257°F MAX
Modes	Indoor Mode: 11ft Protection Zone Outdoor Mode: 16ft Protection Zone
Dimensions	167mm x 59.5mm x 33.5mm (6.6" x 2.3" x 1.3")
Weight	149g±5g (5.26oz±0.1oz) (Accessories Not Included)
Accessories	Heat Insulation Guard, USB-C Charging Cable, 10 x Mosquito Repellent Mats, 2 x 21700 NL2150 5,000mAh Li-ion Batteries (optional)
Powered by	1 or 2 21700 Li-ion Battery(s) to provide a max runtime of 12h
Waterproof Rating	IPX5

Battery Installation

- Slide the Battery Cover Lock Switch on the bottom to open the battery cover.
- Ensure the battery(s) is/are inserted with the negative end towards the spring. The product will not work if the battery(s) is/are incorrectly inserted.
- Cover the battery cover and slide the Battery Cover Lock Switch to lock it.

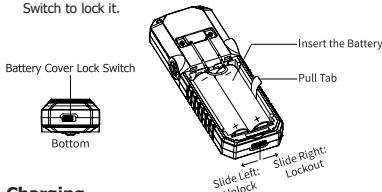

Charging

Connecting to the External Power

Use the USB cable to connect an external power supply (e.g. a USB adapter, a power bank or other USB charging device) to the USB charging port to begin the charging process. (Input: 5V-2.4A / 9V-2A)

Note: The mosquito repelling function and ultrasonic function can be activated during the charging process.

Operating Instructions

Mosquito Repelling Function

- On:** When the mosquito repelling function is off, long press the Mosquito Repelling Button to turn it on, and the corresponding indicator will turn green.
- Off:** When the mosquito repelling function is on, long press the Mosquito Repelling Button to turn it off, and the corresponding indicator will be off.
- Mode Switching:** When the mosquito repelling function is on, short press the Mosquito Repelling Button to switch between Indoor Mode and Outdoor Mode.

Ultrasonic Function

- On:** When the ultrasonic function is off, long press the Ultrasonic Button to turn it on, and the corresponding indicator will turn green.
 - Off:** When the ultrasonic function is on, long press the Ultrasonic Button to turn it off, and the corresponding indicator will be off.
- Note:** Humans can barely hear ultrasound (above 20,000Hz).

Lockout / Unlock

- Lockout:** When both functions are off, double press the Mosquito Repelling Button to access Lockout Mode. In this case, the mosquito repelling function and the ultrasonic function are both unavailable.
- Unlock:** When the product is in the Lockout Mode, double press the Mosquito Repelling Button to unlock the mosquito repelling function and the ultrasonic function.

Hibernation Status

The EMR10 will enter hibernation after 30 seconds if the USB-C port is not in use while the mosquito repelling function and ultrasonic function are off. In this case, the OLED display will be off; press either button to show the remaining battery power.

OLED Real-time Display

- When the mosquito repelling function or ultrasonic function is turned on, the OLED display will show the selected function, selected mode, runtime and more.
- During the charging process, the OLED display will show the charging power, battery percentage and more.
- During the discharging process, the OLED display will show the output power, runtime and more.

Using the EMR10

- When the product is off, insert 1 repellent mat into the Repellent Mat Placement Area.
- Long press the Mosquito Repelling Button to activate the mosquito repelling function.
- The protection zone will be created after 10 minutes.
- After use, long press the Mosquito Repelling Button to turn off the mosquito repelling function. Please store the product after cooling completely.

Note: NITECORE Mosquito Repellent Mat Size: 34mm x 48mm / 1.34" x 1.89" (up to 6 hours each)

Mosquito Repellent Mat Replacement

Make sure the EMR10 is off and cooled. Insert a new repellent mat while pushing out the used one.

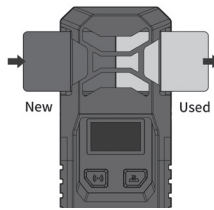

EMR10 Placement

- Place the EMR10 upwind of the mosquito repellent area if it is windy.
- DO NOT cover the EMR10 during the using process.
- It is recommended to use multiple EMR10 together to create a larger protection zone.

Charging the External Device

USB Output: Available with the USB output, the EMR10 can be used as a power supply to charge external devices.

Connecting to the External Device: Use the USB cable to connect an external USB device to the USB charging port to begin the charging process.

Note: During the discharging process, the USB output will be automatically off to protect the battery if the battery voltage is low.

Storage and Transportation

- Store the product in ventilated and dry places at room temperature.
- The battery should be removed to store separately when left unused for a long time.

Warnings

- The product is designed to be used by adults. Keep the product out of reach of children.
- Children under 16 years old must be under adult supervision when using this product to prevent scalds and accidents.
- DO NOT place the product in water.
- DO NOT put your fingers, metals or foreign matters into the product to avoid accidents or damage.
- DO NOT use the product in a confined space.
- Stop using the product and dispose of it immediately if there is any leakage, odor, or deformation in the battery.
- It is recommended to use with NITECORE Li-ion batteries or others with safety certification.
- DO NOT expose the product to temperatures above 60°C (140°F) for a long time.
- DO NOT disassemble or modify the product without authorization, as this will cause the warranty to be nullified. Please check the Warranty Service for details.
- Please install the Heat Insulation Guard when using the product to prevent scalds.
- When using two 21700 Li-ion batteries, please use two with the same capacity while the voltage difference between them is less than 0.1V to avoid damage to the battery or circuit.

Warranty Service

All NITECORE® products are warranted for quality. Any DOA / defective product can be exchanged for a replacement through a local distributor/dealer within 15 days of purchase. After that, all defective / malfunctioning NITECORE® products can be repaired free of charge within 12 months from the date of purchase. Beyond 12 months, the charge for accessories, replacement parts and delivery shall be at your own expenses. The warranty will be nullified if

- the product(s) is/are broken down, reconstructed and/or modified by unauthorized parties.
 - the product(s) is/are damaged due to improper use.
- For the latest information on NITECORE® products and services, please contact a local NITECORE® distributor or send an email to service@nitecore.com
- ⚠️ The trademarks and product images specified herein this user manual are for reference purposes only. The copyright belongs to their lawful holders.
 - ⚠️ All images, texts and statements specified herein this user manual are for reference purposes only. Should any discrepancy occur between this manual and information specified on www.nitecore.com, Sysmax Innovations Co., Ltd. reserves the rights to interpret and amend the content of this document at any time without prior notice.

Worldwide Warranty Service

Model number _____ Date of purchase _____

Serial number _____ Store Stamp _____

This is the certificate of authenticity if this item and we confirm that it has been subjected to the most exacting quality controls by SYSMAX Innovations Co., Ltd.

NOTE:

Please ensure this warranty card is fully completed by the distributor or retailer after purchasing the product. Should the product fail to operate correctly during the warranty period, it may be returned with the completed warranty card and original sales receipt to the retailer or local distributor for replacement or repair.

Customer Service Email: service@nitecore.com

SYSMAX Innovations Co., Ltd.

TEL: +86-20-83862000
FAX: +86-20-83882723
E-mail: info@nitecore.com
Web: www.nitecore.com
Address: Unit 6355, 5/F, No.1021
Gaopu Road, Tianhe District,
Guangzhou, 510653, Guangdong, China



📱 Please find us on facebook: NITECORE China

Thanks for purchasing NITECORE!