

4K Digital Projector

Operating Instructions

Before operating the unit, please read this manual and supplied Safety Regulations thoroughly and retain it for future reference.

SRX-T615

HDMI

Table of Contents

Important Notes	3
Related Manuals	3
On Security	3

Overview

Parts Identification	4
Projector	4
SRX Controller Program Launcher Screen	5
Main Screen of SRX Controller	6

Preparation

Precautions for Installation and Use	9
Unsuitable Environments	9
Unsuitable Operating Conditions	10
Installing SRX Controller on the Controller PC	10
Operating Environment	10
Installing SRX Controller	11
Connecting the Controller PC	12
Connecting to the NETWORK Connector	12
Connecting to the RS-232C Connector	13
Connecting the Projection Source Device	13

Verification

Startup	14
Turning On the Main Power of the Projector	14
Starting SRX Controller	14
Starting the Projector	15
Turning Off the Projector	16

Projection

Projecting Images onto a Screen	17
Masking Images	18
Adjusting the Edge Blending	18

Adjustments and Settings

SRX Controller Adjustments and Settings	19
Storing Setting Values	19
[PICTURE CONTROL] Tab	20
[COLOR CONFIG.] Tab	21
[INSTALLATION] Tab	22
[LENS CONTROL]	22
[ELECTRIC SHIFT FUNCTION]	22
[LAMP POWER]	22
[IMAGE FLIP]	22
[3D GAMMA SELECT]	22
[SINGLE 3D ADJUST]	22
[TEST PATTERN]	23

Miscellaneous

Lamp Replacement Cycles	24
Troubleshooting	24
Messages	25
Projector Maintenance	28
Specifications	29

Trademarks

- Microsoft, Windows, and Windows Vista are trademarks or registered trademarks of Microsoft Corporation in the United States and other countries.
 - Intel and Pentium are registered trademarks of Intel Corporation in the United States and other countries.
 - The terms HDMI and HDMI High-Definition Multimedia Interface, and the HDMI Logo are trademarks or registered trademarks of HDMI Licensing LLC in the United States and other countries.
 - Other products or system names appearing in this document are trademarks or registered trademarks of their respective owners.
- Further, the ® or ™ symbols are not used in the text.

- Reproduction or duplication, in whole or part, of the operation manual supplied with the system without the authorization of the right holder is prohibited under copyright law.
 - Sony assumes no responsibility for damages, loss of income, or any claims from a third party arising out of use of the system.
 - Note that the specifications of the system are subject to change for improvement without prior notice.

Important Notes

Related Manuals

The following manuals are provided for the SRX-T615.

Safety Regulations

This includes instructions and precautions for safe operation of the SRX-T615.

Installation Manual

This includes instructions on how to install and configure initial settings for the SRX-T615, and how to perform adjustments for devices. Refer to this manual whenever you want to change settings or readjust the devices after installation.

Operating Instructions (this manual)

This includes information on projection operations, procedures for adjustment and configuration via SRX Controller, names and functions of parts, and specifications.

Refer to this manual for information on general day-to-day operations.

Maintenance Manual

This includes information such as instructions on periodic inspection, maintenance, and cleaning.

Service Manual

This is intended for use by service personnel and includes information on diagnosing malfunctions and instructions on repair.

On Security

SONY WILL NOT BE LIABLE FOR DAMAGES OF ANY KIND RESULTING FROM A FAILURE TO IMPLEMENT PROPER SECURITY MEASURES ON TRANSMISSION DEVICES, UNAVOIDABLE DATA LEAKS RESULTING FROM TRANSMISSION SPECIFICATIONS, OR SECURITY PROBLEMS OF ANY KIND.

Depending on the operating environment, unauthorized third parties on the network may be able to access the unit. When connecting the unit to the network, be sure to confirm that the network is protected securely.

Parts Identification

Projector

Front

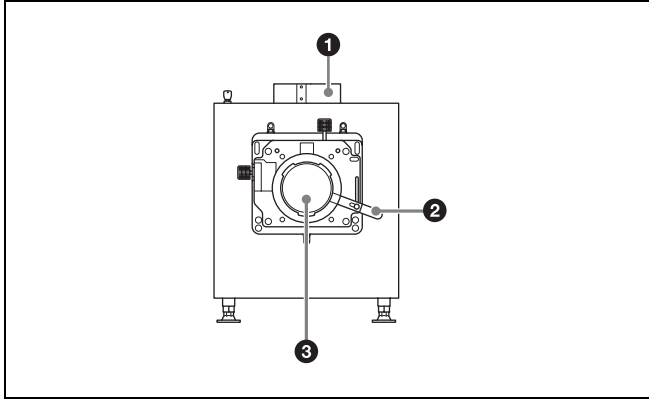

- 1 8-inch duct attachment point**
Attach an exhaust duct here.
- 2 Lens lock lever**
Locks or releases a lens.
- 3 Lens attachment point**
Attach a lens (not supplied) here.

For details on lens attachment or replacement, contact your dealer or your local Sony representative.

Rear

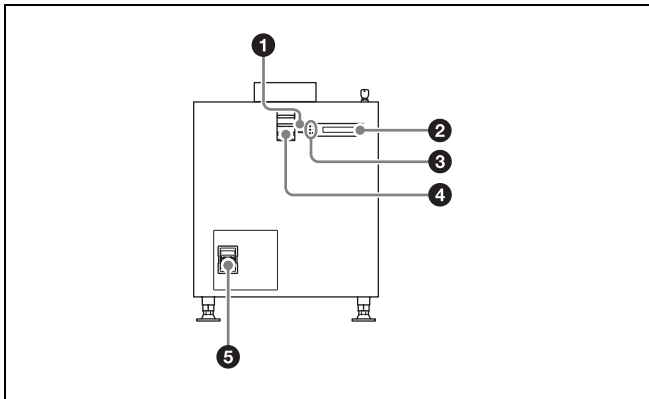

- 1 EMERGENCY switch**
Forces the lamp to turn off (enters standby after cooling).

- 2 Message display window**
Displays various messages (page 25).
- 3 Status indicators**
Indicate the projector's status.

MAIN	LAMP	Projector status
Lit red	Lit red	Standby mode
Lit green	Blinking green (rapid)	Starting up
Lit green	Lit green	Power on (lamp lit)
Lit green	Blinking green (slow)	Power on (lamp off)
Blinking green (rapid)	Blinking green (rapid)	Cooling

Tips

The IMB indicator lights red under normal circumstances. However, this may change depending on the options you install.

- 4 Status lights**
These operate when the server is connected.
- 5 Power switch**
Turns the projector's main power on (I) or off (O).

To turn the projector off

Wait for the lamp's cooling process to complete before turning the power switch off.

For details, see "Turning Off the Projector" (page 16).

Left side

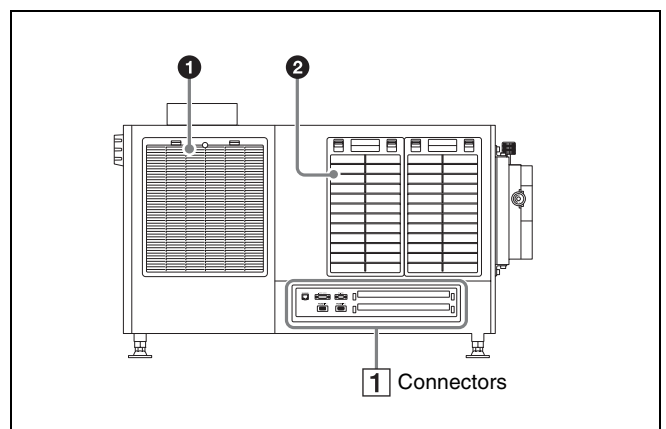

- 1 Lamp access panel (lamp grill) / intake vent / air filter**
A lamp access panel (lamp grill) / intake vent / air filter is also located on the right side of the projector.

2 Intake vent / air filter

For details on lamp replacement or filter cleaning, contact your dealer or your local Sony representative.

1 Connectors

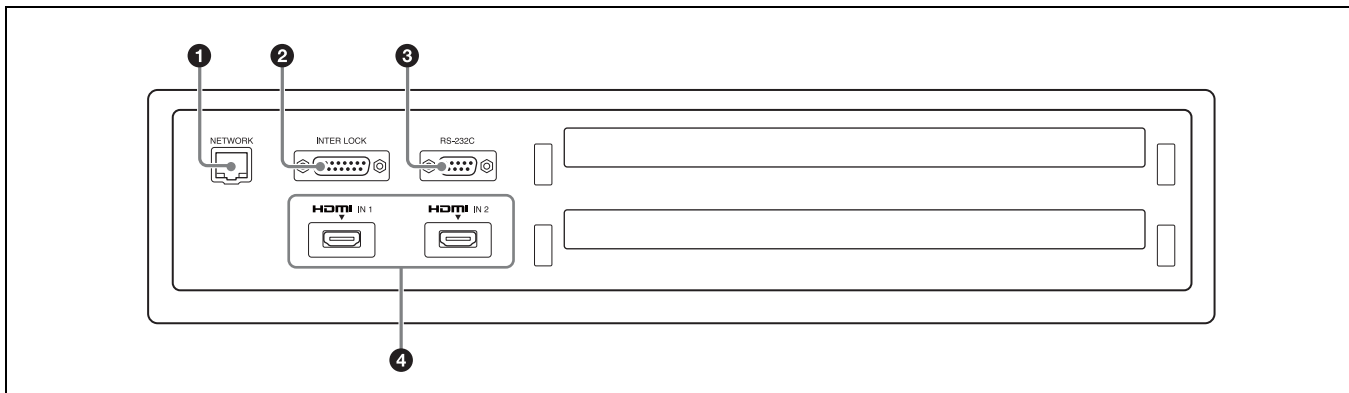

1 NETWORK connector (RJ-45 modular jack)
Connect a LAN cable (not supplied) here and use it to connect to the computer on which the SRX Controller software is installed (controller PC). The controller PC is used to operate the projector.

2 INTER LOCK connector (D-sub 15-pin, female)
Used for maintenance.

3 RS-232C connector (D-sub 9-pin, female)
Connect a connection cable (not supplied) here and use it to connect to the computer on which the SRX Controller software is installed (controller PC). The controller PC is used to operate the projector.

4 HDMI IN 1/2 connectors
Input HDMI signals here.

For details on signal formats, see “HDMI signals” (page 29).

SRX Controller Program Launcher Screen

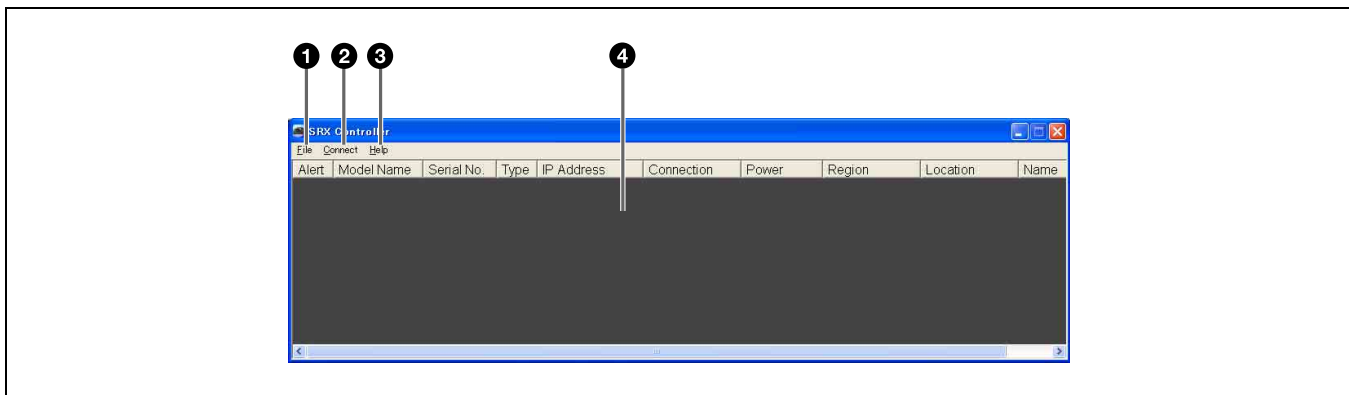

1 [File] menu
Includes the following commands.
[Quit]: Quits SRX Controller.

2 [Connect] menu
Allows you to select the connection mode used to connect the projector and the controller PC. Includes the following commands.
[Network]: Select this when the projector is connected to the controller PC via LAN (page 12).
[COM]: Select this when the projector is connected to the controller PC via RS-232C (page 13).

[PC Port Setting]: Allows you to change the port number.

3 [Help] menu

Includes the following commands.

[Version]: Displays version information for SRX Controller.

4 Projector list

Displays a list of information on projectors that are connected to the same network (subnet). A projector that can be connected via either IPv4 or IPv6 will be listed twice as separate projectors.

When you double-click a projector in the list, connection to the projector is established and the main screen of SRX Controller appears.

[Alert]: Not supported.

[Model Name]: Displays the projector's model name.

[Serial No.]: Displays the projector's serial number.

[Type]: Displays the protocol type (IPv6/IPv4) that can be used for connection.

[IP Address]: Displays the projector's IP address.

[Connection]: Indicates the network connection status.

“Connectable” will appear for projectors that can be selected from SRX Controller.

[Power]: Indicates the power status of the projector.

[Region]: Displays the region in which the projector is installed (only if this information is registered).

[Location]: Displays the location in which the projector is installed (only if this information is registered).

[Name]: Displays the projector's name (only if this information is registered).

Main Screen of SRX Controller

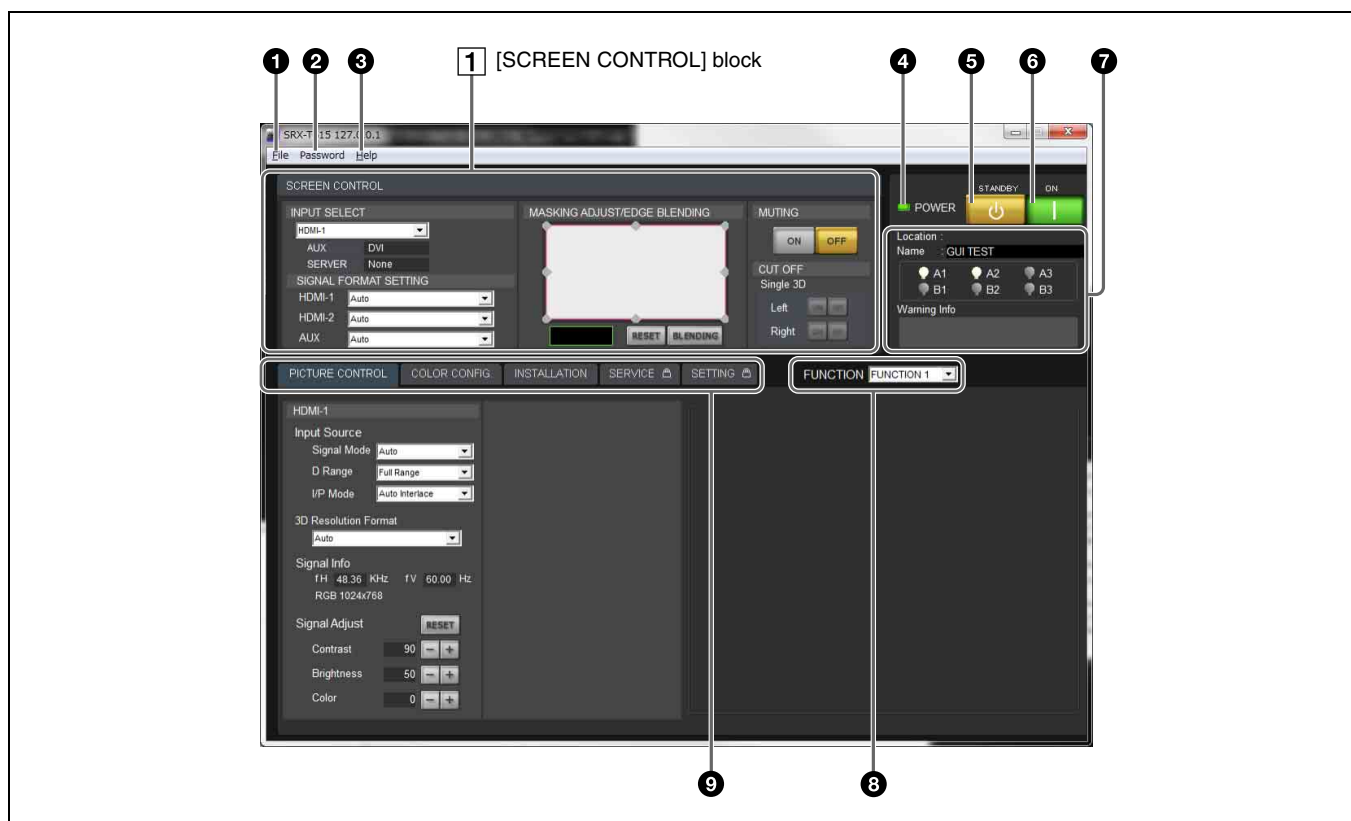

1 [File] menu

Includes the following commands.

[Save Log]: Used for maintenance.

For details, contact your dealer or your local Sony representative.

[Quit]: Quits SRX Controller.

2 [Password] menu

Includes the following commands.

[Reset]: Allows you to reset the password required for authentication when displaying the [SERVICE] and [SETTING] tabs.

This menu only appears when a user with administrator privileges has started SRX Controller.

For details on the [SERVICE] and [SETTING] tabs, contact your dealer or your local Sony representative.

3 [Help] menu

Includes the following commands.

[Version]: Displays version information for SRX Controller.

[Serial]: Displays the projector's serial number.

4 POWER indicator

Displays the projector's status.

Color and light status	Status
Lit green	The projector is ready to be operated via the SRX Controller screen.
Blinking green	Standby mode (cooling)
Lit red	Standby mode

5 (STANDBY) button

Turns the projector off (page 16).

6 (ON) button

When the MAIN and LAMP indicators on the rear of the projector are lit, pressing this button turns the projector on.

When the MAIN and LAMP indicators on the rear of the projector and the POWER indicator on the SRX Controller screen light green, you can control the projector via the SRX Controller screen.

For details, see "Startup" (page 14).

7 Information display area

[Location]: Displays the projector's installation location configured in the [SETTING] tab.

[Name]: Displays the projector's name configured in the [SETTING] tab.

Lamp indicators: Displays lamp status.

Color	Status
White	Functioning normally
Yellow	80% of the recommended replacement cycle's duration has passed.
Red	The recommended replacement cycle's duration has passed.
Gray	The lamp is not lit.
× mark	A lamp error has occurred.

[Warning Info]: Displays an error message if a malfunction occurs on the projector (page 25).

8 [FUNCTION]

Select the FUNCTION you want to use.

You can register adjustments and settings configured for the projector in the SRX Controller screen to FUNCTION 1 to FUNCTION 8, and recall them whenever necessary.

For details, see "Storing Setting Values" (page 19).

9 Tabs

Allow you to perform various adjustments and settings.

[PICTURE CONTROL] tab: Allows you to select the input signal and adjust the picture quality (page 20).

[COLOR CONFIG.] tab: Allows you to configure settings for proper color reproduction (page 21).

[INSTALLATION] tab: Allows you to adjust and configure settings related to projector installation (page 22).

[SERVICE] tab: Allows you to adjust the projector.

A password is required to open this tab. For details, contact your dealer or your local Sony representative.

[SETTING] tab: Allows you to configure projector settings.

A password is required to open this tab. For details, contact your dealer or your local Sony representative.

1 [SCREEN CONTROL] block

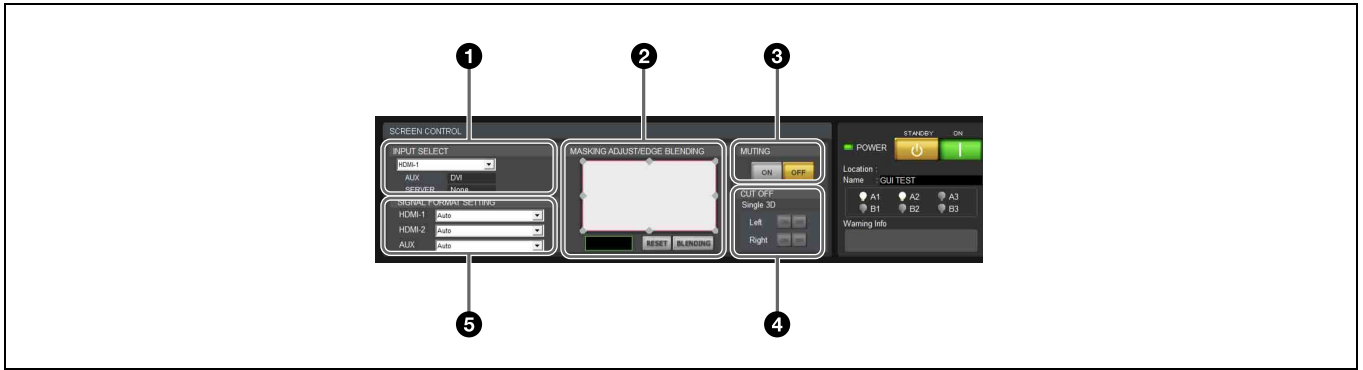

1 [INPUT SELECT] area

Allows you to select the input signal to be projected onto the screen (page 17).

2 [MASKING ADJUST/EDGE BLENDING] area

Allows you to apply black masking to undesired areas of the image according to the screen (page 18). You can also perform edge blending adjustments here (page 18).

3 [MUTING] area

Allows you to display a black screen by blocking all light through the use of a shutter.

[ON]: Temporarily blocks the entire image that is projected onto the screen (i.e., a black screen will be displayed).

[OFF]: Displays the image.

4 [CUT OFF] area

Use this to display 3D images.

For details, contact your dealer or your local Sony representative.

5 [SIGNAL FORMAT SETTING] area

Allows you to fix the format setting to that of the input signal (page 17).

If the input signal is unstable, for example, fixing the format can stabilize the output image.

Preparation

Precautions for Installation and Use

Unsuitable Environments

Do not install the unit in the following types of environments. Doing so may result in malfunctions or damage to the unit.

Poorly ventilated locations

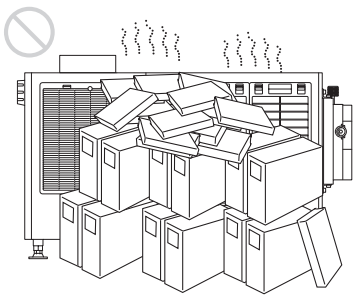

The intake and exhaust vents prevent the unit's interior from overheating. Avoid installation in locations with poor ventilation, and make sure the intake and exhaust vents are free from obstructions.

Locations that obstruct the intake and exhaust vents

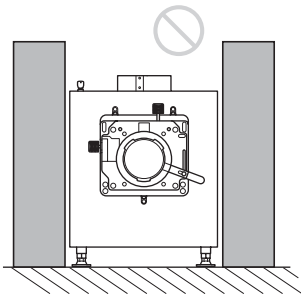

If objects are placed near the exhaust vents located on the top of the unit and on its sides, exhaust will flow into the intake vents. This may cause the unit's interior to overheat and the protection circuit to activate. Be sure to leave sufficient space for the exhaust to escape when installing the unit. Maintain a clearance of about 1 m (39 ³/₈ in.) between the unit and objects.

Locations subject to high temperature and humidity

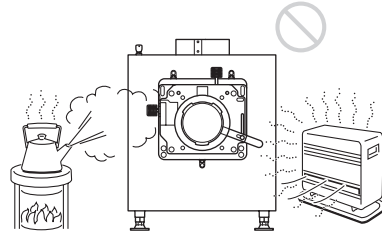

Locations subject to sudden temperature changes

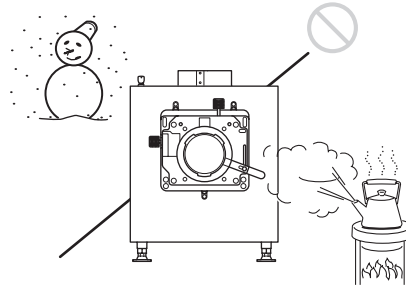

Sudden temperature changes in an enclosed space where the unit is installed will result in condensation, which may in turn result in malfunctions. Be careful when using air conditioners.

Dusty locations

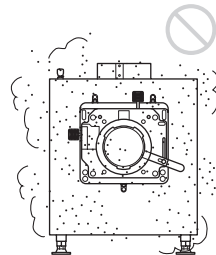

Unsuitable Operating Conditions

Do not operate the unit under the following conditions.

Unit laying on its side or upside down

Unit tilted to the left or right

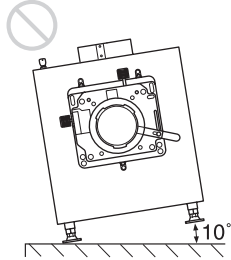

Avoid operating the unit if it is tilted ± 10 degrees or more. Doing so may result in color distortion and significant shortening of the lamp life.

Intake and exhaust vents covered

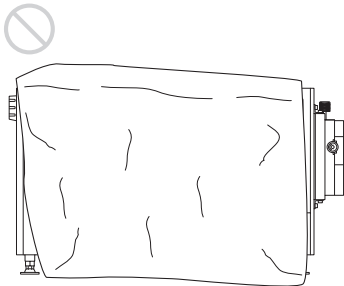

Do not use covers that may obstruct the intake or exhaust vents, and do not operate the unit on thick-piled carpets, for example. Obstructing the intake and exhaust vents will result in overheating of the unit's interior.

For details on the locations of the intake and exhaust vents, see "Parts Identification" (page 4).

Installing SRX Controller on the Controller PC

Install the SRX Controller software on the computer you will use to control the projector.

If a previous version of SRX Controller is already installed on the computer, uninstall the previous version beforehand.

Operating Environment

A computer that meets the following conditions is required to operate SRX Controller.

Operating system (OS):

- Windows XP Professional SP3 (English or Japanese edition, excluding x64 edition)
- Windows Vista Business SP2 (English or Japanese edition, excluding x64 edition)
- Windows 7 Enterprise SP1 (English or Japanese edition)

CPU: Intel Pentium M 1.6 GHz or higher,
OS-recommended CPU

Memory: 256 MB or higher (512 MB or higher recommended), OS-recommended memory

Available HDD space: 15 MB or higher (internal drive)

Monitor: XGA (1024 × 768) or higher

Communication: LAN (10BASE-T/100BASE-TX) or COM (RS-232C)

Windows Vista/7 User Account Control

Windows Vista/7 includes User Account Control (UAC) to improve file security.

SRX Controller supports UAC, and UAC warning messages may appear during installation or operation.

If warning messages appear, perform the following.

If the following screen appears

Select [Allow] to continue with the operation.

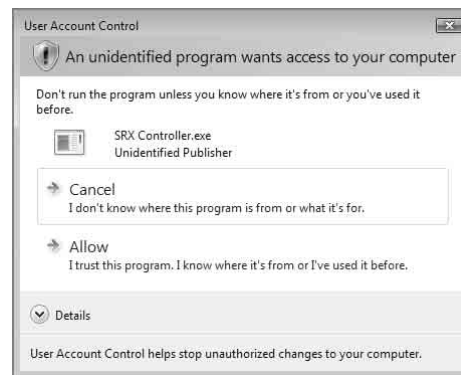

Notes

The application will not run if you select [Cancel].

If the administrator password entry screen appears

Enter the administrator password, and click [OK].



Installing SRX Controller

1 Start the installation wizard that was downloaded via the installer.
The installation wizard starts.

2 Click [Next].



The software license agreement appears.

3 Read the agreement, select [I accept the terms in the license agreement], and then click [Next].
If you select [I do not accept the terms in the license agreement], the software will not be installed and the wizard will close.



4 Select the destination folder for installation, and click [Next].

To change the destination for installation, click [Change] and specify the folder to which you want to install.

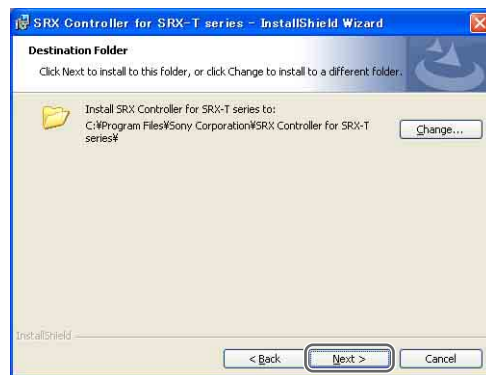

5 Click [Install].



Installation starts.

- 6 When the following screen appears, click [Finish]. If you selected the [Launch the program] checkbox, SRX Controller will start immediately.



This completes installation of SRX Controller. When SRX Controller is installed, the “Start SRX Controller for SRX-T series” icon is created on your desktop.



Connecting the Controller PC

Connect the controller PC to the NETWORK connector or RS-232C connector on the projector, depending on your operating environment.

Notes

If both the NETWORK connector (LAN) and the RS-232C connector (COM) are connected at the same time, communication errors may occur. Use only one connection at a time.

Connecting to the NETWORK Connector

Use a LAN cable (not supplied) to connect the NETWORK connector on the projector to the LAN connector on the controller PC.

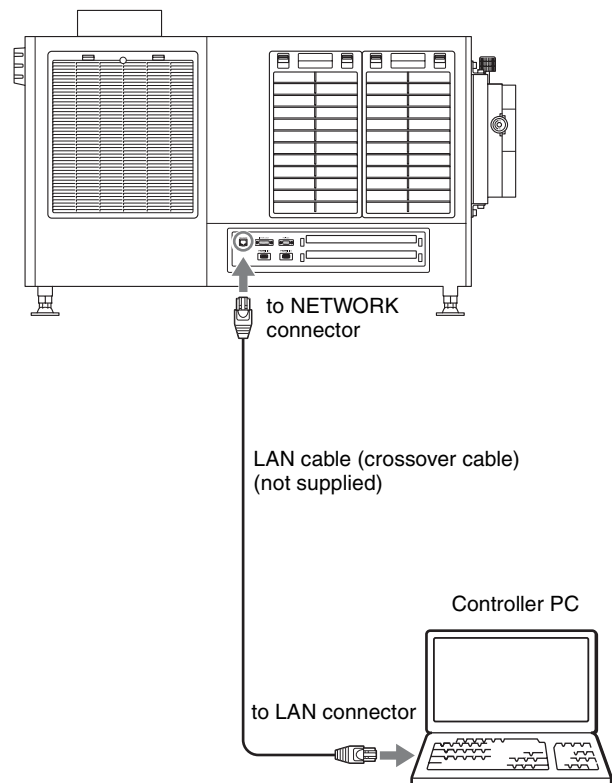

You can also use a LAN cable (straight) (not supplied) and connect to a network via a hub.

Connecting to the RS-232C Connector

Use a connection cable (not supplied) to connect the RS-232C connector on the projector to the RS-232C connector on the controller PC.

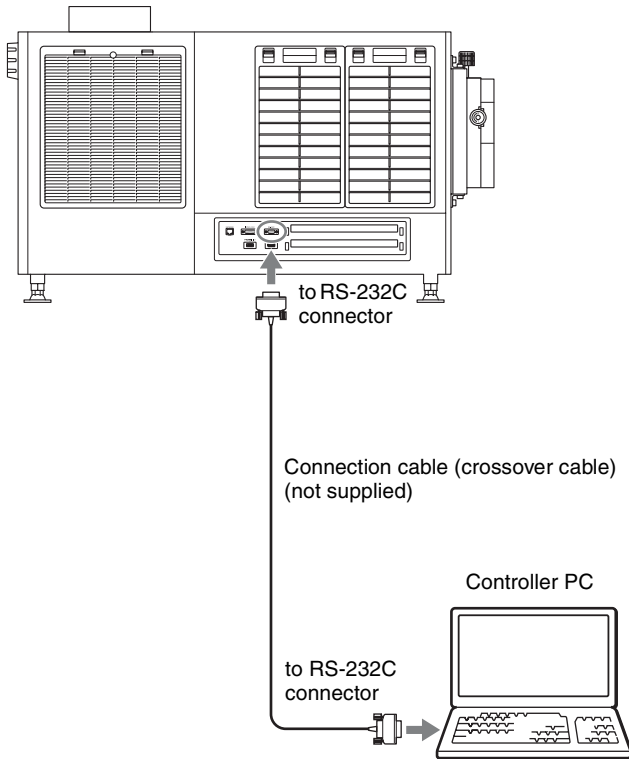

Connecting the Projection Source Device

Notes on connection

- Perform connections for devices with their breakers off or with their power cords disconnected.
- Use appropriate connection cables based on each of the connectors.
- Fully insert all plugs. Incomplete connections may result in image distortion. Be sure to grasp the plug portions when performing disconnections.
- As an additional reference, refer to the operating instructions of the device you want to connect.

For details on supported signals, "HDMI signals" (page 29).

Connect the HDMI IN 1/2 connector on the projector to a device equipped with HDMI output, such as a computer or Blu-ray Disc player.

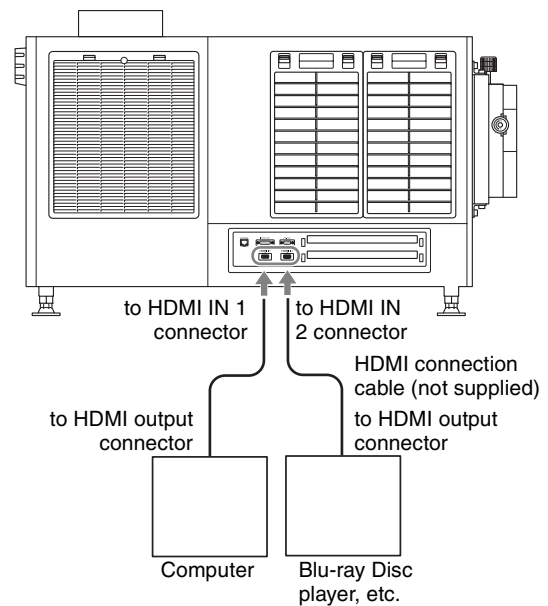

Verification

Startup

Turn on the projector's main power, start SRX Controller, and then start the projector.

Turning On the Main Power of the Projector

Raise the power switch on the rear of the projector to the on position (I) to turn on the projector.

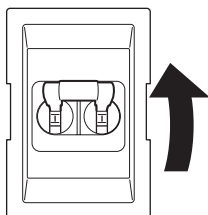

The main power of the projector will turn on and enter the standby mode, the MAIN indicator and LAMP indicator will light red.

Notes

Connect to SRX Controller after initialization of the projector is complete and after the message in the message display window disappears.

Starting SRX Controller

Start SRX Controller, and connect to the projector you want to operate.

Starting the software

If the controller PC is running Windows XP SP3 or later or has commercially available firewall software installed, or the Windows firewall is enabled, the firewall settings must be disabled.

When running Windows XP SP3 or later

- If the following dialog box appears during SRX Controller startup, click [Unblock].



- If the dialog box does not appear and connection to the projector is not possible, open [Windows Firewall] from the [Control Panel], and add “SRX Controller” to the list in the [Exceptions] tab.

When running Windows 7

Start [Windows Firewall], click [Allow a program or feature through Windows Firewall], and select the checkbox for SRX Controller in the list of allowed programs and features. If SRX Controller does not appear in the list, select [Change settings], and then add it by clicking [Add another program].

When commercially available firewall software is installed

Refer to the operating instructions of the firewall software, and add “SRX Controller” to the “authorized” list.

When connected via LAN

- 1 Click  on the desktop. The program launcher screen appears.
- 2 Double-click the projector you want to operate in the projector list.

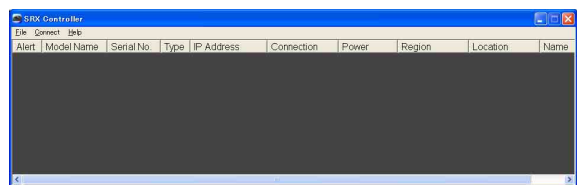

The main screen of SRX Controller appears when connection with the projector is established.

To connect by specifying the projector's IP address

Select [Network] in the [Connect] menu, enter the projector's IP address for [Projector IP Address] in the [Network] dialog box that appears, select [SRX-T600 series] for [Select Model] and then click [OK].

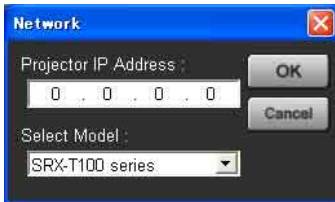

Tips

- Direct specification of the IPv6 address is not supported. When projectors that can be connected via IPv6 exist on the same subnet, they will appear in the projector list, so connect to them from there.
- If other items (services) are enabled for the network connection, projectors may not appear in the projector list of the program launcher screen. In such cases, disable that item (service) or connect to projectors by specifying their IPv4 addresses.
- To change the port number, select [PC Port Setting] in the [Connect] menu, and enter the port number in the dialog box that appears.
- The projector's IPv4 address will appear in the message display window when the main power is turned on using the breaker. Match the IPv4 address of the computer you are using, and perform connection.

When connected via RS-232C

- 1 Click  on the desktop. The program launcher screen appears.
- 2 Select [COM] in the [Connect] menu. The [COM] dialog box appears.
- 3 Enter the controller PC's COM port (RS-232C) for [COM Port], select [SRX-T600 series] for [Select Model], and then click [OK].



The main screen of SRX Controller appears when connection with the projector is established.

Quitting SRX Controller

Select [Quit] in the [File] menu.

Starting the Projector

Click  at the top right of the main screen of SRX Controller.



The MAIN and LAMP indicators on the projector and the POWER indicator on the main screen of SRX Controller light green.

This completes the preparations and verifications required to project images onto a screen.

Turning Off the Projector

- 1 Click  at the top right of the main screen of SRX Controller.
A confirmation screen appears.
- 2 Click [OK].

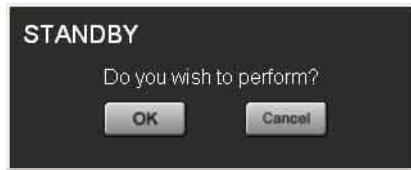

The MAIN and LAMP indicators on the rear of the projector will begin to blink green to indicate that cooling is in progress. When cooling is complete, the LAMP indicator will light red. Wait a moment. While cooling is in progress, the POWER indicator on the main screen of SRX Controller will also blink green.

- 3 When the MAIN and LAMP indicators light red, lower the breaker to the off position (○) to turn off the main power.

Notes

Do not turn off the projector using its power switch. Forcibly turning off the projector using the power switch may result in insufficient cooling of the lamp, which may in turn cause shortening of the lamp life and malfunctions.

Projecting Images onto a Screen

Operations for projection are performed in the SRX Controller screen.

- 1 Turn on the main power of the projector (page 14).
- 2 SRX Controller starts, and connection with the projector is established (page 14).
- 3 Start the projector (page 15).
- 4 Turn on the source device of the images.
- 5 Select the input signal under [INPUT SELECT] of the [SCREEN CONTROL] block.

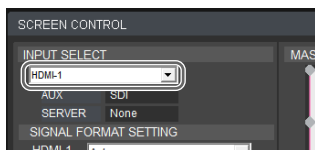

HDMI-1: Project images from the device connected to the HDMI IN 1 connector.

HDMI-2: Project images from the device connected to the HDMI IN 2 connector.

AUX × 1: When a 4K option board is installed, project the 2K input signal.

AUX × 4: When a 4K option board is installed, project the 4K input signal.

SERVER: Intended for future expansion.

Notes

- If the [Signal Mode] is not configured correctly under [Input Source] in the [PICTURE CONTROL] tab, the image may be distorted.
- For details on connector locations for optional external input boards, refer to the operating instructions supplied with the external input boards.

For details, see “[PICTURE CONTROL] Tab” (page 20).

- 6 Select the format of the input signal under [SIGNAL FORMAT SETTING] of the [SCREEN CONTROL] block.

The default setting value is [Auto].

If noise enters the signal when you extend the cable, for example, fixing the format to that of the received signal format can stabilize the image.

When receiving low-level or low-quality signals with the [Auto] setting, the image may lag and go black momentarily. Fixing the signal format in such cases will result in steady image output.

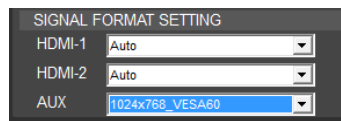

Notes

- Consider the resolution of the source video that will be projected onto the screen when selecting the signal format in [SIGNAL FORMAT SETTING].
 - The maximum resolution for AUX × 1 is 2048 × 1080.
 - The maximum resolution for AUX × 4 is 4096 × 2160.
- When a setting other than [Auto] is selected under [SIGNAL FORMAT SETTING], a freeze function will activate when noise enters the signal. As a result, when you turn off the computer, the final shutdown screen may continue to be displayed. The screen will remain even though the computer is turned off as a result of the freeze function. This is not a malfunction.
- When a setting other than [Auto] is selected under [SIGNAL FORMAT SETTING] and that input is selected in [INPUT SELECT], the following items in the [PICTURE CONTROL] tab will be grayed out and cannot be selected.
 - [I/P Mode] of [Input Source]
 - [3D Resolution Format]
- When you switch the [SIGNAL FORMAT SETTING] setting from [Auto] to a fixed resolution, noise may occur during the transition to the fixed mode in some cases. When switching input signal formats, we recommend storing the switch to a FUNCTION, or using [MUTING] in conjunction with the switching operation.

- 7 Display the [INSTALLATION] tab, and adjust the focus and viewing angle under [LENS CONTROL].

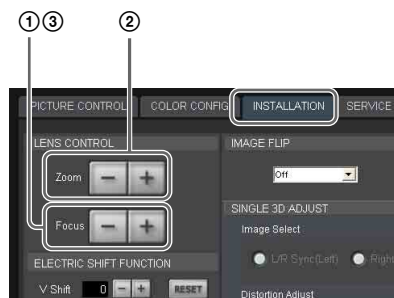

- ① Click [-] or [+] for [Focus] to adjust the focus.
- ② Click [-] or [+] for [Zoom] to adjust the picture size.
- ③ Adjust the focus again with [Focus].

Blocking the entire image

Click the [ON] button under [MUTING] in the [SCREEN CONTROL] block to block the image and make the entire screen go black.

Clicking the [OFF] button restores the image display.



Masking Images

You can apply black masking to undesired areas of the image according to the screen.

You can adjust any of the eight adjustment points.

- 1 Double-click one of the adjustment points under [MASKING ADJUST/EDGE BLENDING] in the [SCREEN CONTROL] block. The adjustment screen appears.
- 2 While viewing the image projected on the screen, click the [-] or [+] buttons for [Horizontal] or [Vertical], or enter values to perform adjustments.

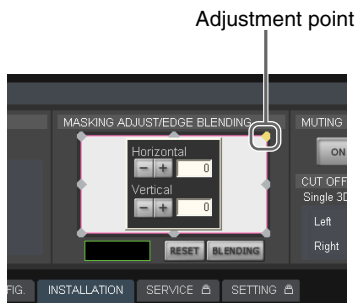

- 3 Repeat the above for each adjustment point to mask the image.

Restoring the default adjustment values

Click [RESET] to restore all the adjustment points to their default values.

Adjusting the Edge Blending

You can adjust the edge blending to smoothen the joints between multiple images when conjoining images from multiple projectors.

Configure the areas you want to blend and the widths as follows.

- To blend the left and right edges: Set [Horizontal] to “the blending width + 48.”
- To blend the top and bottom edges: Set [Vertical] to “the blending width + 50.”

This section describes how to blend horizontally using a right-edge blending width of 512 as an example.

- 1 Double-click the top right adjustment point under [MASKING ADJUST/EDGE BLENDING] in the [SCREEN CONTROL] block, and enter “560” for [Horizontal] in the adjustment screen that appears. Setting value: Blending width 512 + 48 = 560



- 2 Double-click the bottom right adjustment point, and enter “560” for [Horizontal] in the adjustment screen that appears. Setting value: Blending width 512 + 48 = 560



- 3 Click [BLENDING].

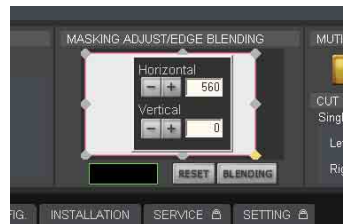

The [EDGE BLENDING] screen appears.

- 4 Set [Right] to [ON], and select [512] for [Width]. If you set [Marker] to [On], green and red lines will appear at the start and end positions of blending, respectively.



Notes

We recommend setting [Upper] and [Lower] to [256] or [512].

- 5 When you finish configuration, click [CLOSE].

Adjustments and Settings

SRX Controller Adjustments and Settings

Adjustments and settings are performed in the various tabs of the SRX Controller screen.

This section describes the setting items in each tab.

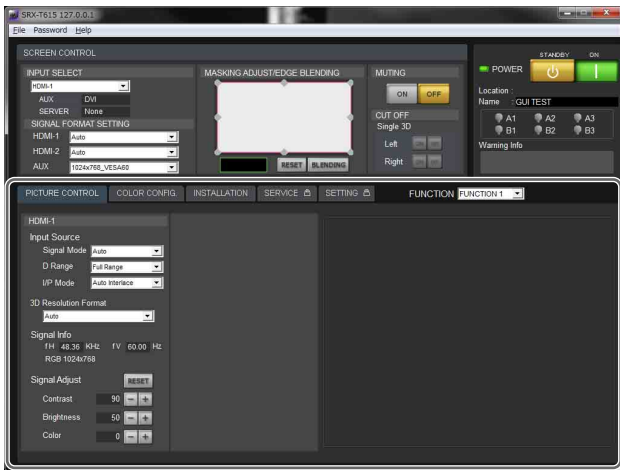

Items that cannot be adjusted

Depending on the input signal, some setting items cannot be configured. Setting items that cannot be configured will not appear in the SRX Controller screen.

Storing Setting Values

Settings and adjustments configured for the projector can be registered to a FUNCTION to be recalled whenever necessary.

You can register up to 8 FUNCTIONS (FUNCTION 1 to FUNCTION 8).

Registering setting values to FUNCTIONS

Setting values are stored to FUNCTION 1 under factory default conditions.

To register additional FUNCTIONS, perform the following.

- 1 Select the FUNCTION you want to register in the [FUNCTION] drop-down list.

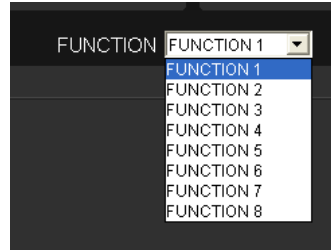

- 2 Perform adjustments and settings in each tab. The current setting values will be stored to the selected FUNCTION.

Recalling FUNCTIONS

Select the FUNCTION you want to recall in the [FUNCTION] drop-down list.

Notes

When you switch to a different FUNCTION, the image will temporarily enter the muting state for up to about 10 seconds. Afterward, the image will appear according to the selected settings.

[PICTURE CONTROL] Tab

You can select the input signal and adjust the picture quality in the [PICTURE CONTROL] tab.

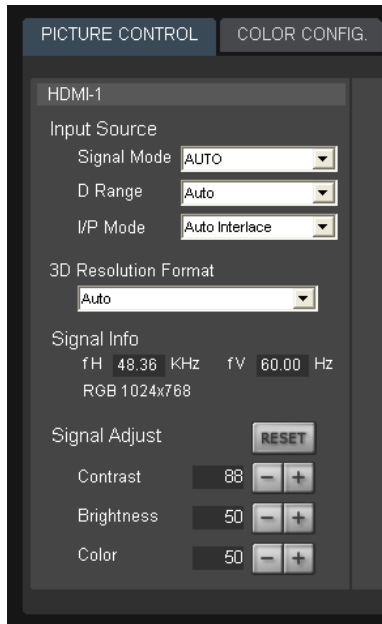

[Input Source]

[Signal Mode]

Select the type of signal that is input from the device connected to the input board.

[D Range]

Set the dynamic range to [Full Range], [Limited Range], or [Auto].

[Limited Range] assumes that the signal includes restricted codes, and performs adjustments so that data values 64 to 960 are at a 0% to 100% image levels in the case of a 10-bit signal. When the signal includes restricted codes, select [Limited Range].

[I/P Mode]

Select the I/P conversion mode.

Select [Auto Interlace] or [Auto PsF] depending on the signal source.

[Signal Info]

Displays the horizontal and vertical frequencies automatically. The values are rough estimates.

The input signal type is displayed under the frequency values.

[fH]: Displays the horizontal frequency.

[fV]: Displays the vertical frequency.

Notes

If [Single 3D] is selected for [INPUT SELECT], signal information will not be displayed in the right eye settings if it is common to the left eye settings.

[Signal Adjust]

Adjust the picture quality of the input signal.

Click [+] to increase a setting value, and click [-] to decrease it.

Clicking the [RESET] button restores all the setting values below it to their default values.

[Contrast]

Adjust the contrast.

Increasing the value increases the contrast.

[Brightness]

Adjust the brightness.

Increasing the value increases the brightness.

[Color]

Adjust the color density.

Increasing the value increases the color density.

Notes

If [Single 3D] is selected for [INPUT SELECT], items will not be displayed in the right eye settings if they are common to the left eye settings.

[COLOR CONFIG.] Tab

You can configure input signal settings in the [COLOR CONFIG.] tab.

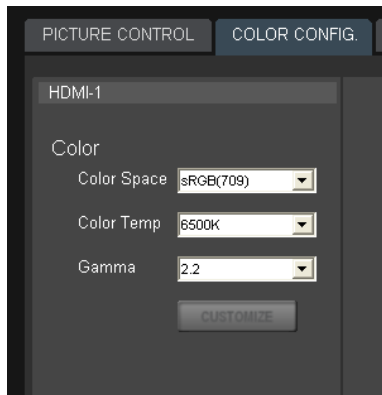

To specify a gamma value, select [Custom] in the drop-down list, click [CUSTOM], and enter a gamma value in the [Input Gamma Data] dialog box that appears.



[Color]

Configure settings for proper color reproduction. If the color in the image is incorrect, first check the [Color Space] setting.

[Color Space]

Select the tonal reproduction range.

sRGB (709): Select this when projecting standard HD signals and RGB signals.

DCDM: Select this when projecting DCI specification signals.

To reproduce colors for this setting, an optional filter replacement accessory is required.

Adobe RGB: Select this when projecting Adobe RGB compatible signals.

To reproduce colors for this setting, an optional filter replacement accessory is required.

CUSTOM1 to CUSTOM12: Select these when projecting images using user-defined color spaces.

[Color Temp]

Set the color temperature to [DCI W/P], [6500K], or [custom1] to [custom4].

We recommend selecting [6500K] when projecting standard HD signals and RGB signals.

[Gamma]

Select the gamma correction mode.

Smaller numerical values increase the brightness. Select the mode based on the image source.

We recommend specifying 2.2 when projecting standard HD signals and RGB signals.

Based on the input signal, select 2.6 or 2.2 for the gamma value, or specify a value between 1.80 and 2.6 (0.01 increments).

[INSTALLATION] Tab

You can adjust the screen, select the projector orientation, and adjust lamp output in the [INSTALLATION] tab.



[3D GAMMA SELECT] and [SINGLE 3D ADJUST] are used when projecting 3D images. For details, contact your dealer or your local Sony representative.

[LENS CONTROL]

Adjust the image projected onto the screen.

[Zoom]

Adjust the image size.

Click [+] to increase the size, and click [-] to decrease it.

[Focus]

Adjust the focus.

Click [+] to focus on far objects, and click [-] to focus on nearby objects.

[ELECTRIC SHIFT FUNCTION]

Digitally adjust the top, bottom, left, and right positions of the projected image.

[H Shift]

Adjust the horizontal position of the image.

Increase the value to move the image to the right, and decrease the value to move it to the left.

[V Shift]

Adjust the vertical position of the image.

Increase the value to move the image up, and decrease the value to move it to down.

[RESET]

Restore each setting to its default value.

[LAMP POWER]

Adjust the brightness of the image.

Click the [-] and [+] buttons to specify a value between 80% and 100%.

Specify values for [Level1] to [Level3]. [Level3] should be the brightest.

[IMAGE FLIP]

Flip the image according to the orientation of the projector. Off: Do not flip the image. Select this for normal projection.

H: Flip the left and right sides of the image.

V: Flip the top and bottom of the image.

HV: Flip the top and bottom, and the left and right sides of the image.

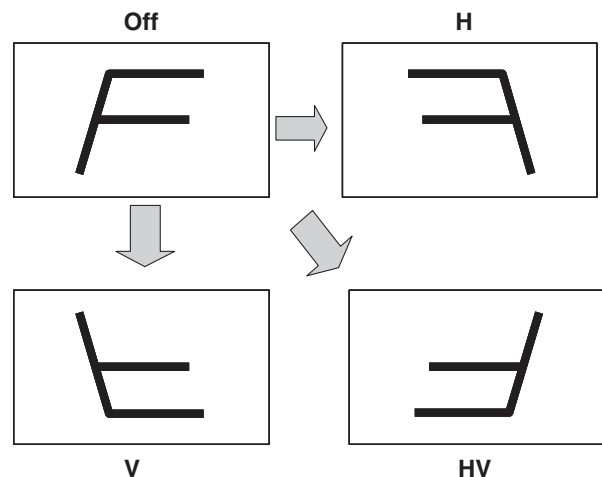

[3D GAMMA SELECT]

Select from three types of uniformity tables.

For details on using this function, refer to the Installation Manual.

[SINGLE 3D ADJUST]

For details on adjustment, refer to the Installation Manual.

[TEST PATTERN]

Display test patterns that are stored internally on the projector to adjust the image without signal inputs from a separate device.

You can select from the [Cross Hatch], [Cross Hatch (Invert)], [Checker Flag], [Test Mode1], [Scope], and [Flat] test patterns.

If you do not want to display a test pattern, select [Off].

Notes

- The [INPUT SELECT] and [FUNCTION] settings cannot be changed while internal test patterns are displayed. In addition, adjustment of some items in the [PICTURE CONTROL] and [COLOR] tabs will be disabled.
- While internal test patterns are displayed, some picture quality settings will be set to optimal configurations automatically, and adjustment of these settings will be disabled. However, turning off the test pattern will restore original conditions.

[SINGLE 3D] is used when projecting 3D images. For details, contact your dealer or your local Sony representative.

Lamp Replacement Cycles

The approximate lamp replacement cycle is as follows.

Model name	Recommended cycle
LKRM-U330 (330 W)	3,000 hours
LKRM-U450 (450 W)	2,000 hours

The approximate usage times for lamps is indicated by the color of the lamp indicators at the top right of the SRX Controller screen.

Lamp indicators



Usage time (%)	Color
0 to 80	White
80 to 100	Yellow
100 or more	Red
Error	× mark

Troubleshooting

Check the following before requesting repairs.

If the problem persists, contact your dealer or your local Sony representative.

Power

Symptom	Cause	Solution
The power does not turn on.	The main power is not turned on.	Set the power switch on the rear of the projector to the raised position (page 14).
	The projector is not connected properly to the controller PC.	Connect the connection cables properly (page 12).
	The lamp's exhaust duct is not connected.	Contact your dealer or your local Sony representative.
"Error 52" appears.	Errors are occurring due to power supply noise.	After setting the breaker on the rear of the projector to the off position for about 30 seconds, perform verification of operation again. If the problem persists, contact your dealer or your local Sony representative.

Images

Symptom	Cause	Solution
The image does not appear.	The connection cables are disconnected.	Check the connections (page 13).
	The input is not selected properly.	Check that the input signal is selected properly under [INPUT SELCT] in the [SCREEN CONTROL] block (page 17).
	The image is muted.	Click [OFF] for [MUTING] in the [SCREEN CONTROL] block (page 8).
	The ambient temperature is too high.	Adjust the ambient temperature to within the projector's operating temperature range (5 °C to 35 °C (41 °F to 95 °F)).
The color is incorrect.	The input signal mode is configured incorrectly.	Based on the input signal, specify the correct [Signal Mode] under [Input Source] in the [PICTURE CONTROL] tab (page 20).

Symptom	Cause	Solution
The image lags or is frozen, or the angle of view is incorrect.	A setting other than [Auto] is selected under [SIGNAL FORMAT SETTING] of the [SCREEN CONTROL] block and the input signal does not match.	Reconfigure the [SIGNAL FORMAT SETTING] settings to match the input signal, or select [Auto] (page 17).
The image is dark.	The contrast and brightness settings are incorrect.	Specify the correct [Contrast] and [Brightness] in the [PICTURE CONTROL] tab (page 20).
	The lamp output setting is incorrect.	Specify the correct [LAMP POWER] in the [INSTALLATION] tab (page 22).

Controls

Symptom	Cause	Solution
The main screen of SRX Controller does not appear.	The projector and controller PC are not connected properly.	Connect the connection cables properly (page 12).

Messages

The following messages appear in the message display window on the rear of the projector. Error messages also appear under [Warning Info] in the main screen of SRX Controller.

Projector (rear)

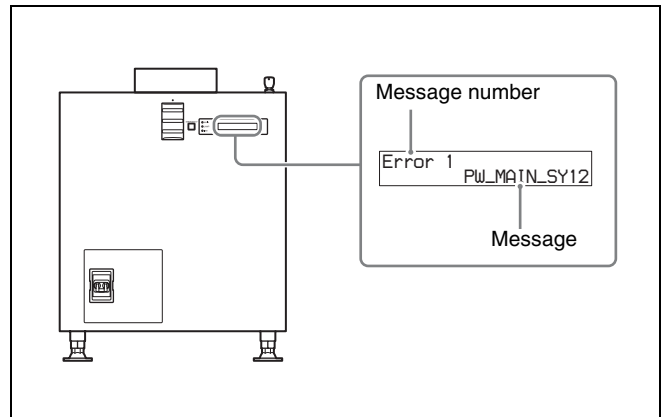

Error messages are separated into the following three categories based on severity. If an error occurs, a message number and error message appear in the display window.

Error (severity: high): The projector will be shut down forcibly.

Warning (severity: medium): Operation will continue, but the problem should be resolved as soon as possible.

Info (severity: low)

If an error message appears, contact your dealer or your local Sony representative with the message number and error message.

Error (severity: high)

Message No.	Message
Error 1	PW_MAIN_SY12
Error 2	PW_MAIN_SY26
Error 3	PW_MAIN_SY7-1
Error 4	PW_MAIN_SY7-2
Error 5	PW_MAIN_FE3.3
Error 6	PW_MAIN_FE2.5
Error 7	PW_MAIN_FE1.8
Error 8	PW_MAIN_FE1.2MX
Error 9	PW_MAIN_FE1.0MX
Error 10	PW_MAIN_FE1.2IN
Error 11	PW_MAIN_FE1.5DC

Message No.	Message
Error 12	PW_MAIN_FE1.2DC
Error 13	PW_MAIN_FE1.0DC
Error 14	PW_MAIN_FE1.5S1
Error 15	PW_MAIN_FE1.5S2
Error 16	PW_MAIN_FE1.2HD
Error 17	PW_MAIN_FE12
Error 18	PW_MAIN_LPDPN_B
Error 19	PW_MAIN_LPDPN_G
Error 20	PW_MAIN_LPDPN_R
Error 21	PW_MAIN_LPDP0_B
Error 22	PW_MAIN_LPDP1_B
Error 23	PW_MAIN_LPDP0_G
Error 24	PW_MAIN_LPDP1_G
Error 25	PW_MAIN_LPDP0_R
Error 26	PW_MAIN_LPDP1_R
Error 27	PW_MAIN_LPD1.2C
Error 28	PW_MAIN_LPD3.0C
Error 29	PW_MAIN_LPD26
Error 30	PW_MAIN_LPD12
Error 31	PW_MAIN_LPD3.3
Error 32	PW_MAIN_LPD3.3P1
Error 33	PW_MAIN_LPD3.3P0
Error 34	PW_MAIN_LPD1.0R1
Error 35	PW_MAIN_LPD1.0R2
Error 36	PW_MAIN_LPD1.8R1
Error 37	PW_MAIN_LPD1.8R2
Error 38	PW_MAIN_LPD3.3R
Error 39	PW_MAIN_LPD3.3R
Error 40	PW_MAIN_STACK
Error 41	PW_MAIN_OPTION
Error 42	PW_BLK_MAIN
Error 52	PW_BLK_PFC_ALL
Error 100	DET_BOARD_FE
Error 101	DET_BOARD_LED
Error 102	DET_BOARD_CCM
Error 103	DET_BOARD_LPD
Error 104	DET_BOARD_IF
Error 105	DET_BOARD_CT
Error 106	DET_PEL_R
Error 107	DET_PEL_G
Error 108	DET_PEL_B
Error 201	TMP_AIR_2
Error 205	TMP_PNL_R_2
Error 206	TMP_PNL_G_2
Error 207	TMP_PNL_B_2

Message No.	Message
Error 209	TMP_OPT_2
Error 216	TMP_LMP_A1_2
Error 217	TMP_LMP_A2_2
Error 218	TMP_LMP_A3_2
Error 219	TMP_LMP_B1_2
Error 220	TMP_LMP_B2_2
Error 221	TMP_LMP_B3_2
Error 228	TMP_LMPPW_A1_2
Error 229	TMP_LMPPW_A2_2
Error 230	TMP_LMPPW_A3_2
Error 231	TMP_LMPPW_B1_2
Error 232	TMP_LMPPW_B2_2
Error 233	TMP_LMPPW_B3_2
Error 241	TMP_PFC_1_2
Error 242	TMP_PFC_2_2
Error 243	TMP_PFC_3_2
Error 245	TMP_PWUNIT_2
Error 247	TMP_FE_2
Error 248	TMP_BUILT-IN_A
Error 249	TMP_BUILT-IN_B
Error 300	O_INST_CHI_FAN1
Error 302	O_INST_LMPDOR1
Error 303	O_INST_LMPDOR2
Error 304	O_GPIO_INTERLOCK
Error 305	O_LMPINFO_TYPE
Error 306	O_LMPINFO_DET_A1
Error 307	O_LMPINFO_DET_A2
Error 308	O_LMPINFO_DET_A3
Error 309	O_LMPINFO_DET_B1
Error 310	O_LMPINFO_DET_B2
Error 311	O_LMPINFO_DET_B3
Error 1005	ACT_FAN_PNL_R1
Error 1006	ACT_FAN_PNL_R2
Error 1007	ACT_FAN_PNL_G
Error 1008	ACT_FAN_PNL_B
Error 1009	ACT_FAN_UV
Error 1010	ACT_FAN_PS
Error 1011	ACT_FAN_LMP_A1
Error 1012	ACT_FAN_LMP_A2
Error 1013	ACT_FAN_LMP_A3
Error 1014	ACT_FAN_LMP_B1
Error 1015	ACT_FAN_LMP_B2
Error 1016	ACT_FAN_LMP_B3
Error 1080	ACT_LMP_ALL
Error 1081	ACT_LMP_POWOUT

Warning (severity: medium)

Message No.	Message
Warning 43	PW_BLK_LMP_A1
Warning 44	PW_BLK_LMP_A2
Warning 45	PW_BLK_LMP_A3
Warning 46	PW_BLK_LMP_B1
Warning 47	PW_BLK_LMP_B2
Warning 48	PW_BLK_LMP_B3
Warning 49	PW_BLK_PFC_1
Warning 50	PW_BLK_PFC_2
Warning 51	PW_BLK_PFC_3
Warning 200	TMP_AIR_1
Warning 202	TMP_PNL_R_1
Warning 203	TMP_PNL_G_1
Warning 204	TMP_PNL_B_1
Warning 208	TMP_OPT_1
Warning 210	TMP_LMP_A1_1
Warning 211	TMP_LMP_A2_1
Warning 212	TMP_LMP_A3_1
Warning 213	TMP_LMP_B1_1
Warning 214	TMP_LMP_B2_1
Warning 215	TMP_LMP_B3_1
Warning 222	TMP_LMPPW_A1_1
Warning 223	TMP_LMPPW_A2_1
Warning 224	TMP_LMPPW_A3_1
Warning 225	TMP_LMPPW_B1_1
Warning 226	TMP_LMPPW_B2_1
Warning 227	TMP_LMPPW_B3_1
Warning 238	TMP_PFC_1_1
Warning 239	TMP_PFC_2_1
Warning 240	TMP_PFC_3_1
Warning 244	TMP_PWUNIT_1
Warning 246	TMP_FE_1
Warning 301	O_INST_CHI_FAN2
Warning 313	O_MEM_LENS
Warning 314	O_MEM_OPTICAL
Warning 315	O_MEM_OPTION
Warning 321	O_TIMER_LMP_A1
Warning 322	O_TIMER_LMP_A2
Warning 323	O_TIMER_LMP_A3
Warning 324	O_TIMER_LMP_B1
Warning 325	O_TIMER_LMP_B2
Warning 326	O_TIMER_LMP_B3
Warning 327	O_TIMER_FILTER
Warning 328	O_NS_RTC_BAT

Message No.	Message
Warning 333	O_MEASURE_LMP_A1
Warning 334	O_MEASURE_LMP_A2
Warning 335	O_MEASURE_LMP_A3
Warning 336	O_MEASURE_LMP_B1
Warning 337	O_MEASURE_LMP_B2
Warning 338	O_MEASURE_LMP_B3
Warning 1000	ACT_FAN_PWB
Warning 1001	ACT_FAN_FE
Warning 1002	ACT_FAN_PFC1
Warning 1003	ACT_FAN_PFC2
Warning 1004	ACT_FAN_PFC3
Warning 1017	ACT_FAN_LMPPOW1
Warning 1018	ACT_FAN_LMPPOW2
Warning 1019	ACT_FAN_LMPPOW3
Warning 1020	ACT_FAN_POWUNT1
Warning 1021	ACT_FAN_POWUNT2
Warning 1022	ACT_COM_AERO_04
Warning 1023	ACT_COM_AERO_05
Warning 1024	ACT_COM_AERO_06
Warning 1025	ACT_COM_AERO_10
Warning 1026	ACT_COM_AERO_11
Warning 1027	ACT_COM_AERO_12
Warning 1028	ACT_COM_AERO_13
Warning 1029	ACT_COM_AERO_14
Warning 1030	ACT_COM_AERO_15
Warning 1031	ACT_COM_AERO_18
Warning 1032	ACT_COM_AERO_24
Warning 1033	ACT_COM_AERO_25
Warning 1034	ACT_COM_AERO_26
Warning 1035	ACT_COM_AERO_28
Warning 1036	ACT_COM_AERO_29
Warning 1037	ACT_COM_AERO_2A
Warning 1038	ACT_COM_AERO_2B
Warning 1039	ACT_COM_AERO_2C
Warning 1040	ACT_COM_AERO_30
Warning 1041	ACT_COM_AERO_32
Warning 1042	ACT_COM_AERO_33
Warning 1043	ACT_COM_AERO_34
Warning 1044	ACT_COM_AERO_36
Warning 1045	ACT_COM_AERO_37
Warning 1046	ACT_COM_AERO_38
Warning 1047	ACT_COM_AERO_39
Warning 1048	ACT_COM_AERO_3A
Warning 1049	ACT_COM_AERO_44
Warning 1050	ACT_COM_AERO_45

Message No.	Message
Warning 1051	ACT_COM_AERO_48
Warning 1052	ACT_COM_AERO_49
Warning 1053	ACT_COM_AERO_4A
Warning 1054	ACT_COM_AERO_4B
Warning 1055	ACT_COM_AERO_4C
Warning 1056	ACT_COM_AERO_4D
Warning 1057	ACT_COM_AERO_50
Warning 1058	ACT_COM_AERO_52
Warning 1059	ACT_COM_AERO_A4
Warning 1060	ACT_COM_AERO_A8
Warning 1061	ACT_COM_AERO_B0
Warning 1062	ACT_COM_LMPPW_A1
Warning 1063	ACT_COM_LMPPW_A2
Warning 1064	ACT_COM_LMPPW_A3
Warning 1065	ACT_COM_LMPPW_B1
Warning 1066	ACT_COM_LMPPW_B2
Warning 1067	ACT_COM_LMPPW_B3
Warning 1068	ACT_LMP_START_A1
Warning 1069	ACT_LMP_START_A2
Warning 1070	ACT_LMP_START_A3
Warning 1071	ACT_LMP_START_B1
Warning 1072	ACT_LMP_START_B2
Warning 1073	ACT_LMP_START_B3
Warning 1074	ACT_LMP_OFF_A1
Warning 1075	ACT_LMP_OFF_A2
Warning 1076	ACT_LMP_OFF_A3
Warning 1077	ACT_LMP_OFF_B1
Warning 1078	ACT_LMP_OFF_B2
Warning 1079	ACT_LMP_OFF_B3
Warning 1082	ACT_LENS_Z_INIT
Warning 1083	ACT_LENS_Z_AUTO
Warning 1084	ACT_LENS_F_AUTO
Warning 1085	ACT_LENS_Z_ADJ
Warning 1086	ACT_LENS_F_ADJ
Warning 1090	ACT_LUM_SENS_COM

Info (severity: low)

Message No.	Message
Info 312	O_SW_LMPOFF
Info 339	O_LMP_PAT_CHG
Info 348	O_SIG_HDMI_1
Info 349	O_SIG_HDMI_2
Info 350	O_SIG_AUX

Projector Maintenance

On abnormal noise

The projector is equipped with a fan to prevent heat internal build-up, and some noise will be generated when the projector is turned on. However, if the noise generated is abnormally loud, consult your dealer or local Sony representative.

On illumination

Do not expose the screen to direct lighting or sunlight. To obtain the best picture, obey the following.

- Use light-condensing recessed lights.
- Use mesh covers for fluorescent lighting and other scattered light sources.
- Cover any windows that permit sunlight to enter with curtains or blinds.
- If the floor or walls are of light-reflecting material, cover them with carpets or wall paper.

On cleaning

- Periodically clean the cabinet and panels with a soft cloth. For stubborn stains, use a soft cloth lightly dampened with a mild detergent diluted with water. Always turn off the power switch before cleaning.
- Avoid touching the lens with your hands or hard objects that may scratch the lens.

On condensation

If the room temperature where the projector is installed changes rapidly, or if the projector is moved suddenly from a cold to a warm place, condensation in the projector may occur. As the condensation may cause malfunction, be careful in adjusting temperature settings of the air conditioner. If condensation occurs, leave the projector with the power turned off until it is sufficiently dry before operating it any further.

On periodic inspection

The projector includes some consumable parts that degrade over a long period of use.

To keep the projector working properly and to prolong its usable lifetime, have the projector inspected periodically. We recommend you make a maintenance contract for periodical inspection with us. For details on the contract, consult your dealer or local Sony representative.

Specifications

Optical system

Projection method	SXRD (Silicon X-tal Reflective Display), 3-panel prism color integration system
Resolution (H × V)	4096 × 2160 pixels
Lamp	450 W, high-pressure mercury (HPM) lamps (6), or 330 W, high-pressure mercury (HPM) lamps (6)
Light output	18,000 lumens (average) (LKRM-U450 450 W lamps × 6) 13,000 lumens (average) (LKRM-U330 330 W lamps × 6)
Contrast	12,000:1 (average)

I/O

Video input	HDMI (2) Expansion slots (2)
RS-232C	D-sub 9-pin, female (1)
LAN	10 Base-T, 100 Base-TX (1)

General

Operating temperature	5 °C to 35 °C (41 °F to 95 °F)
Operating humidity	35% to 85% (non-condensing)
Storage temperature	-20 °C to +60 °C (-4 °F to +140 °F)
Storage humidity	10% to 90%
Power	200 V to 240 V AC, 50/60 Hz, single phase, 21.5 A to 18 A
Power consumption	LKRM-U450 450 W lamp: Max. 4.3 kW LKRM-U330 330 W lamp: Max. 3.2 kW
Dimensions	548 × 634 × 1,119 mm (21 ⁵ / ₈ × 25 × 44 ¹ / ₈ in.) (W × H × D) (including lens shift block and feet; excluding status light, ducts, etc.)
Weight	Approx. 143 kg (315 lb. 5 oz.) (excluding lamps)

Supplied accessories

- Housing removal keys (5)
- Safety Regulations (1)

Design and specifications are subject to change without notice.

Notes

- Always verify that the unit is operating properly before use. SONY WILL NOT BE LIABLE FOR DAMAGES OF ANY KIND INCLUDING, BUT NOT LIMITED TO, COMPENSATION OR REIMBURSEMENT ON ACCOUNT OF THE LOSS OF PRESENT OR PROSPECTIVE PROFITS DUE TO FAILURE OF THIS UNIT, EITHER DURING THE WARRANTY PERIOD OR AFTER EXPIRATION OF THE WARRANTY, OR FOR ANY OTHER REASON WHATSOEVER.
- SONY WILL NOT BE LIABLE FOR CLAIMS OF ANY KIND MADE BY USERS OF THIS UNIT OR MADE BY THIRD PARTIES.
- SONY WILL NOT BE LIABLE FOR THE TERMINATION OR DISCONTINUATION OF ANY SERVICES RELATED TO THIS UNIT THAT MAY RESULT DUE TO CIRCUMSTANCES OF ANY KIND.

HDMI signals

The projector supports the following HDMI signals.

2D

Resolution	Frame rate
720 × 480	59.94p/60p
720 × 480	59.94i/60i
720 × 576	50p
720 × 576	50i
1280 × 720	59.94p/60p
1280 × 720	50p
1920 × 1080	59.94p/60p
1920 × 1080	50p
1920 × 1080	23.98p/24p
1920 × 1080	59.94i/60i
1920 × 1080	50i
VGA (640 × 480)	60
XGA (1024 × 768)	60
UXGA (1600 × 1200)*	60
WUXGA (1920 × 1200)*	60
2048 × 1080**	23.98/24
2048 × 1080**	60

* Projection is not possible when a 3D lens is mounted.

** Sony proprietary specification.

3D

3D format	Resolution	Frame rate
Frame Packing (progressive)	1280 × 720	59.94p/60p
Frame Packing (progressive)	1280 × 720	50p
Frame Packing (progressive)	1920 × 1080	23.98p/24p
Top & Bottom	1920 × 1080	59.94p/60p
Top & Bottom	1920 × 1080	50p
Top & Bottom	1920 × 1080	23.98p/24p
Top & Bottom	1280 × 720	59.94p/60p
Top & Bottom	1280 × 720	50p
Side by Side	1280 × 720	59.94p/60p
Side by Side	1280 × 720	50p
Side by Side	1920 × 1080	59.94p/60p
Side by Side	1920 × 1080	50p
Side by Side	1920 × 1080	59.94i/60i
Side by Side	1920 × 1080	50i
2 inputs	1920 × 1080	59.94p/60p
2 inputs	1920 × 1080	50p
2 inputs	1920 × 1080	23.98p/24p
2 inputs	1920 × 1080	59.94i/60i
2 inputs	1920 × 1080	50i
2 inputs	1280 × 720	59.94p/60p
2 inputs	1280 × 720	50p

